

## Installation Instructions

### Part List



**(1) 4016L-43-003 Qty 1-**



**(2) 4016L-43-002 Qty 1-**



**(3) 4016L-43-001 Qty 2-**



**(4) 4016L-10-005 Qty 1-**



**(5) 4016L-43-004L Qty 1-**



**(6) 4016L-43-004R Qty 1-**



**(7) 4016L-43-006 Qty 1-**

### Mounting Bolt Kit

(A) Qty 2 - M10 x 25mm Hex Bolt	
(B) Qty 4 - M10 Lock Washer	
(C) Qty 6 - M10 Flat Washer	
(D) Qty 4 - 5/16" x 3/4" Carriage Bolt	
(E) Qty 4 - 5/16" Flat Washer	
(F) Qty 4 - 5/16"-18 Nylock Nut	
(G) Qty 4 - 3/8" Nylon Spacer	
(I) Qty 6 - 1/4"-20 x 7/8" Hex Bolt	
(J) Qty 14 - 1/4" Flat Washer	
(H) Qty 2- 3/8"-16 Nylock Nut	

(K) Qty 6 - 1/4"-20 Nyloc Nut	
(M) Qty 2 - 1/4" Lock Washer	
(N) Qty 1 - 5/16" x 3/4" Self Tapping Bolt	
(O) Qty 2 - M8 x 25mm Hex Bolt	
(P) Qty 1 - M8 x 45mm Hex Bolt	
(Q) Qty 1 - M8 Nyloc Nut	
(R) Qty 2 - M6 x 25mm Hex Bolt	
(S) Qty 2 - 5/16 x 1.25" Self-tapping screws	
(T) Qty 2 - 3/8"-16 x 1" Carriage Bolt	
(U) Qty 3- 5/16" Lock Washer	

## 4832L Installation Instructions for Ford Transit Connect

**WARNING: LIFT, DO NOT DRAG THE SHELF UNIT INTO POSITION**

### Step 1

Assemble 4832L

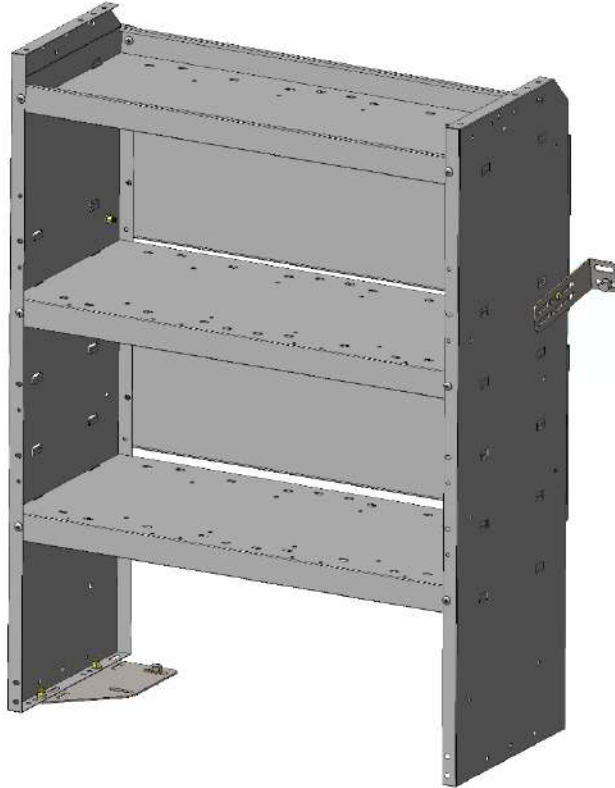

### Step 2

Attach 4016L-43-002 (bracket) to the rear side of the shelf using one 1/4" x 7/8" bolt(I), two 1/4" flat washers(J), one 1/4" Nyloc nut(K) in the order shown below. Attach through the top slot in the bracket and the hole provided in the support panel.

HAND TIGHTEN ONLY

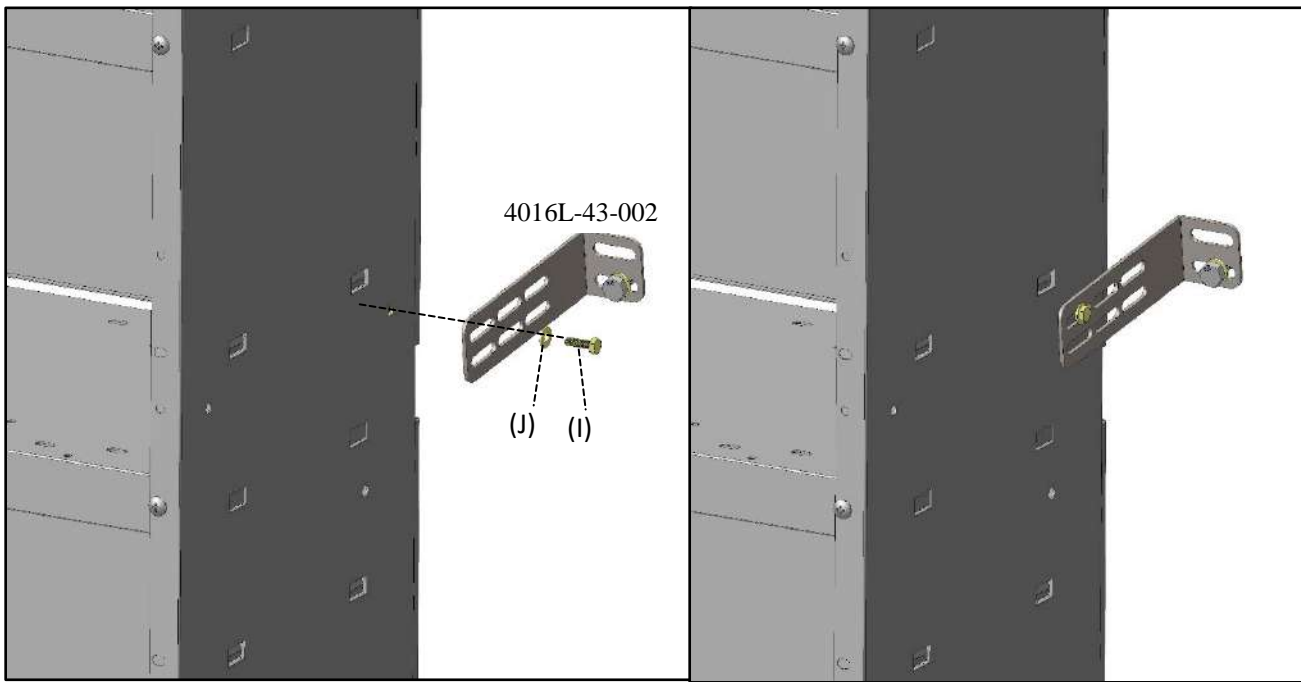

**Step 3**

Attach 4016L-43-003 (bracket) to the opposite side of the shelf through the bottom slot using one 1/4" x 7/8" bolt (I), two 1/4" flat washers(J), one 1/4"Nyloc nut(K)in the order shown below.

HAND TIGHTEN ONLY

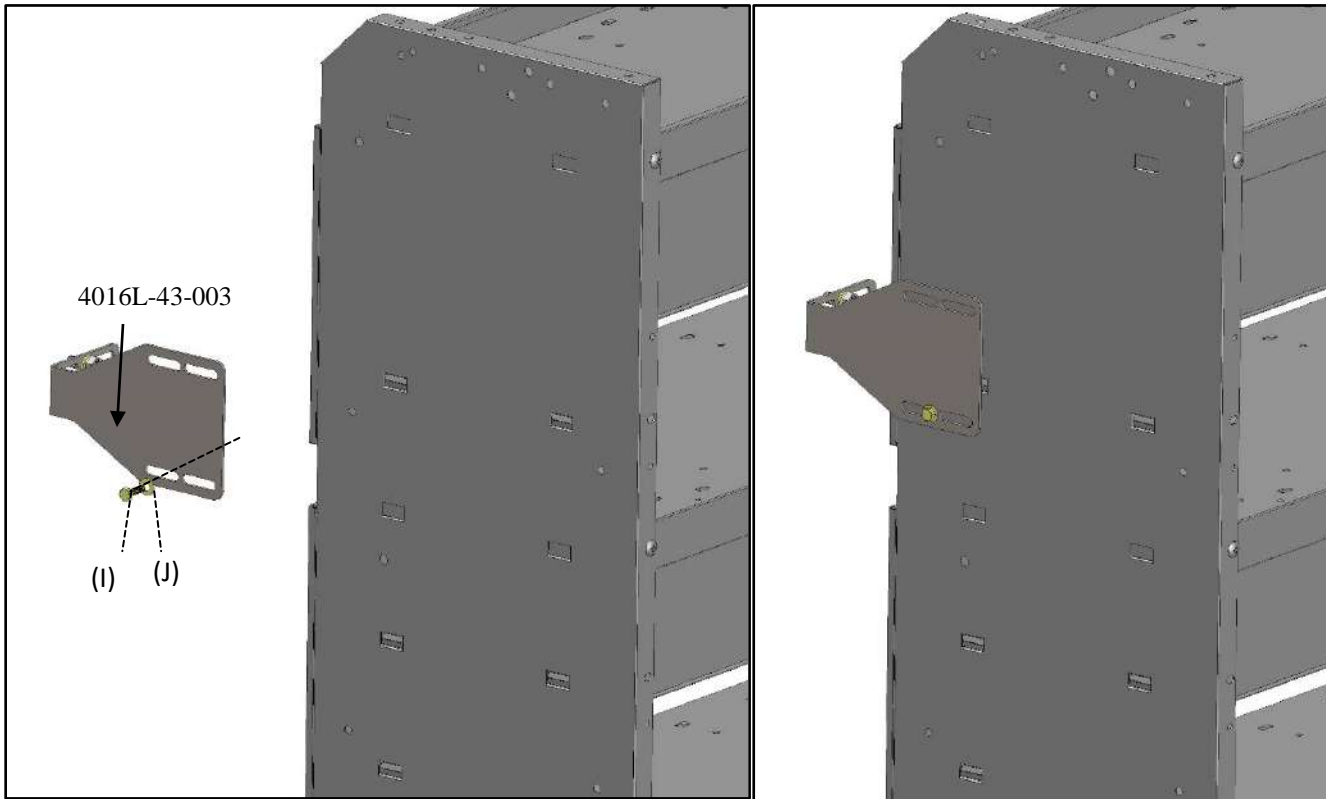

**Step 4**

Attach 4016L-43-001 (bracket) to the bottom side of the support using two 5/16" x 3/4" carriage bolt(D), two 5/16" flat washers(E), two 5/16"Nyloc nuts(F) in the order shown below. Bolts go through center hole on shelving unit.

HAND TIGHTEN ONLY

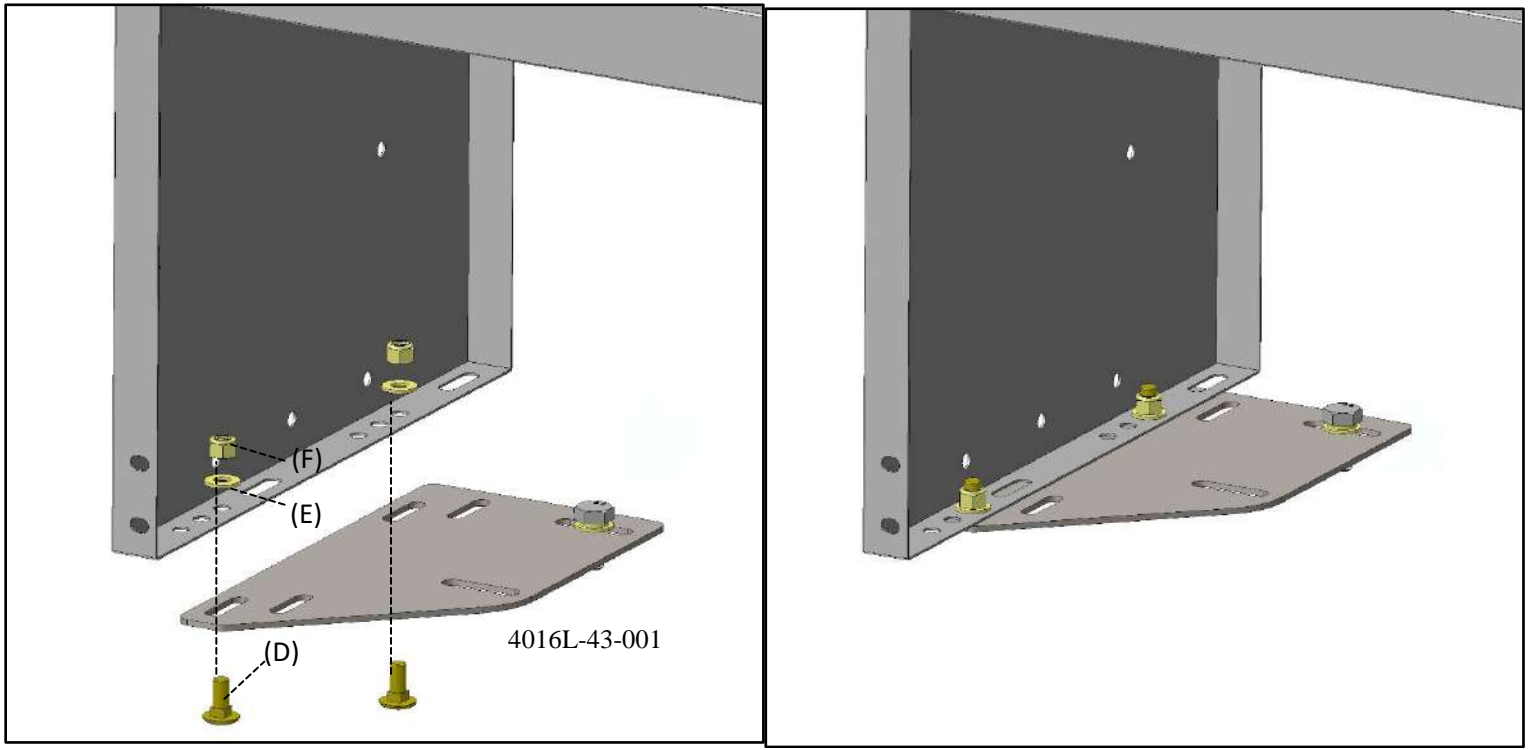

**Step 5**

Remove D-Ring from floor of van located on the passenger side to the rear of the door.

\*\* Keep Bolt

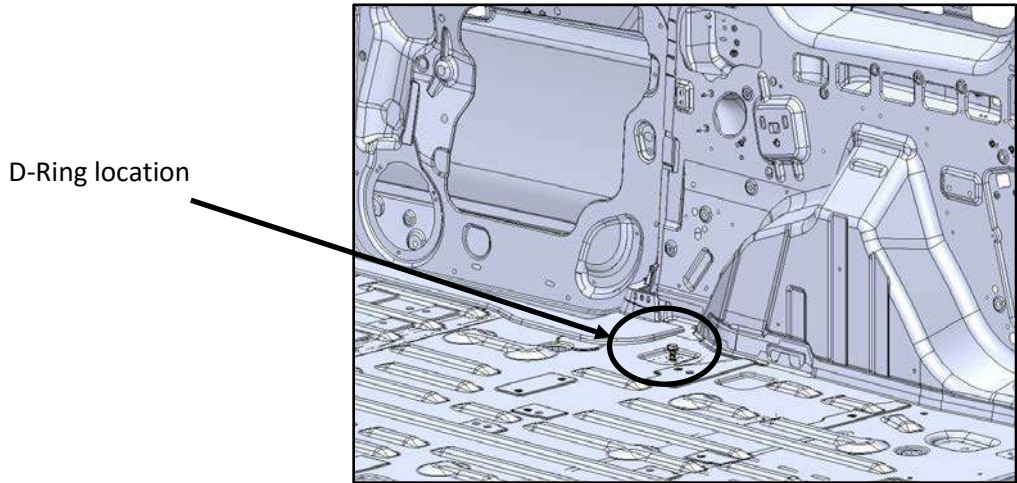

**Step 6**

Place shelving unit in rear of van on the passenger side behind the sliding door.

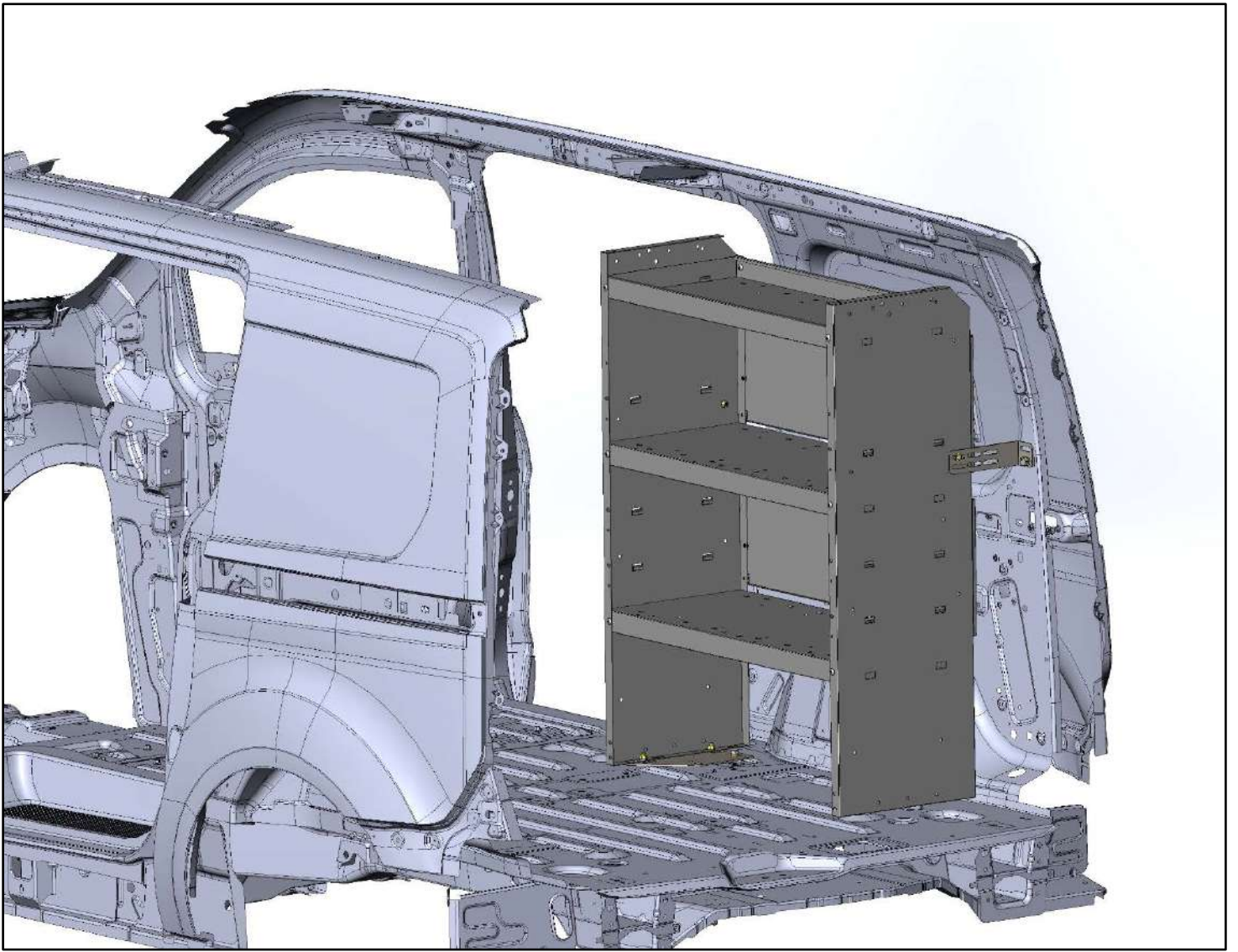

### **Step 7**

Align 4016L-43-001 (bracket) to the existing D-Ring mount. Use bolt from step 2 with nylon spacers (as needed) to bolt down 4016L-43-001 (bracket).

**HAND TIGHTEN ONLY**

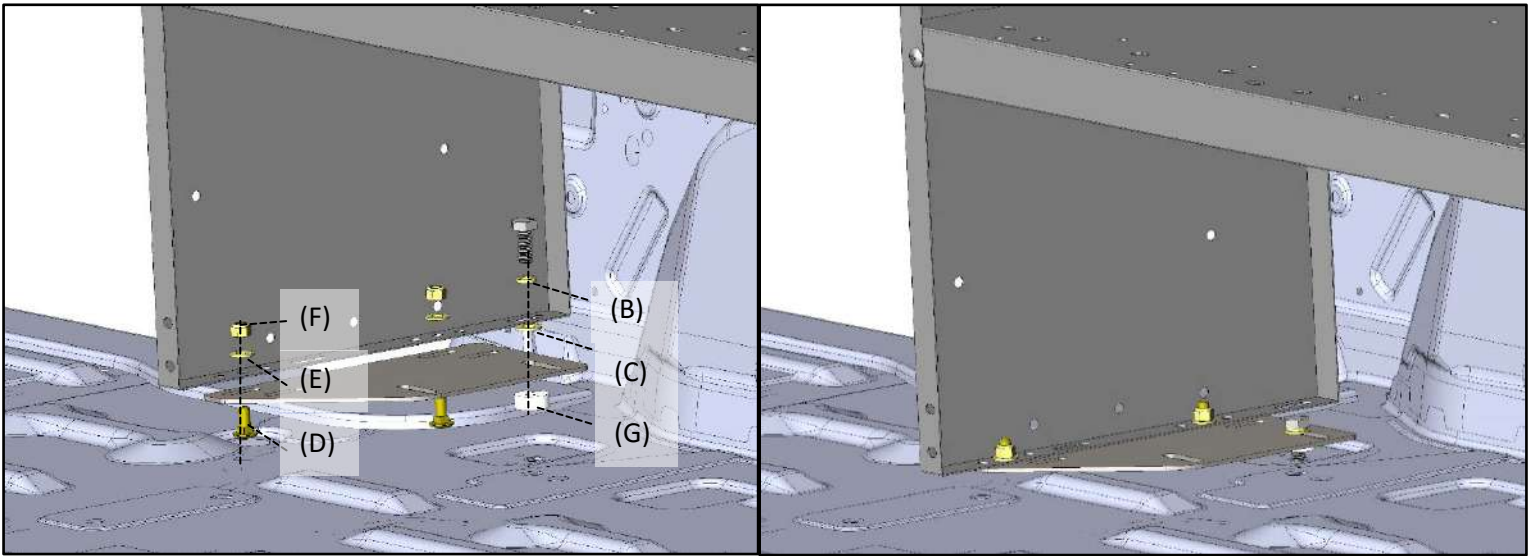

### **Step 8**

Align 4016L-43-002 (bracket) to embossed hole on panel near rear door. Attach bracket to the side panel using one M10 x 25 Hex bolt(A), one M10 lock washer(B) and one M10 flat washer(C). Use the bottom slot on the bracket.

**HAND TIGHTEN ONLY**

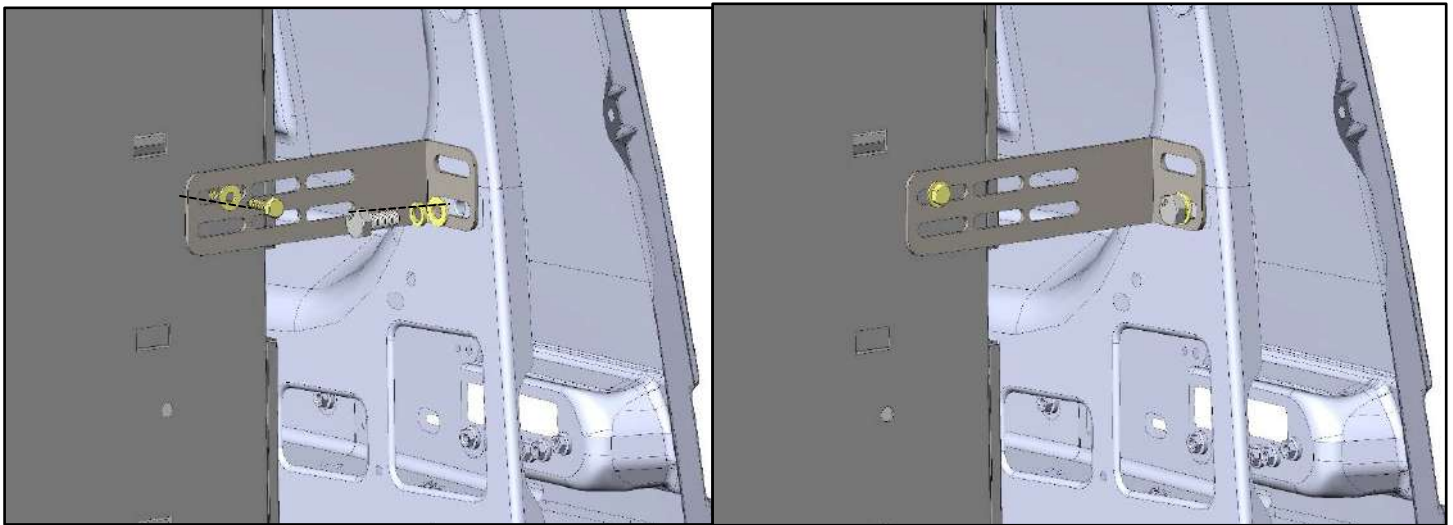

### **Step 9**

Align top slot on 4016L-43-003 (bracket) to the embossed hole on panel near sliding door. Attach bracket to the side panel using one M10 x 25 Hex bolt(A), one M10 lock washer(B) and one M10 flat washer(C). **HAND TIGHTEN ONLY**

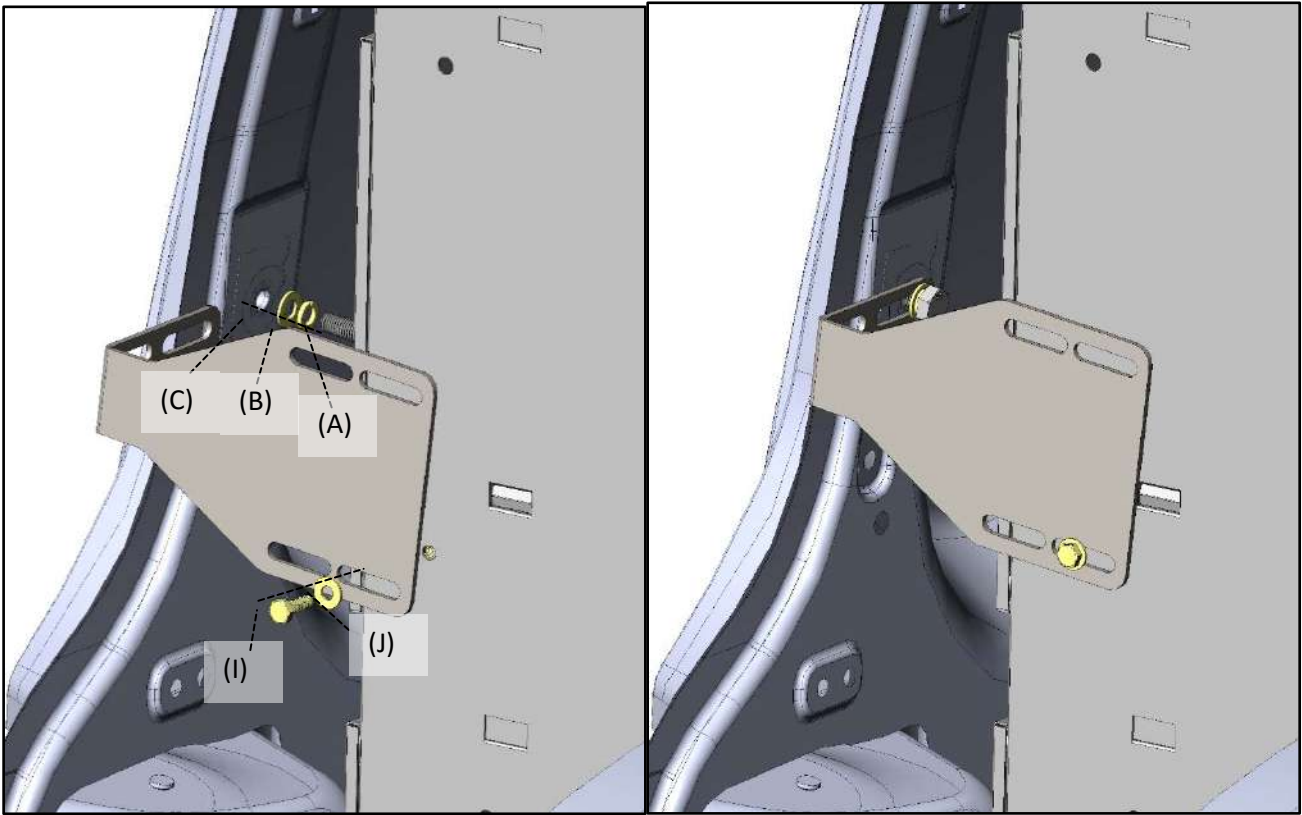

**Step 10**

Level and align shelf. Finish by tightening all nuts and bolts.

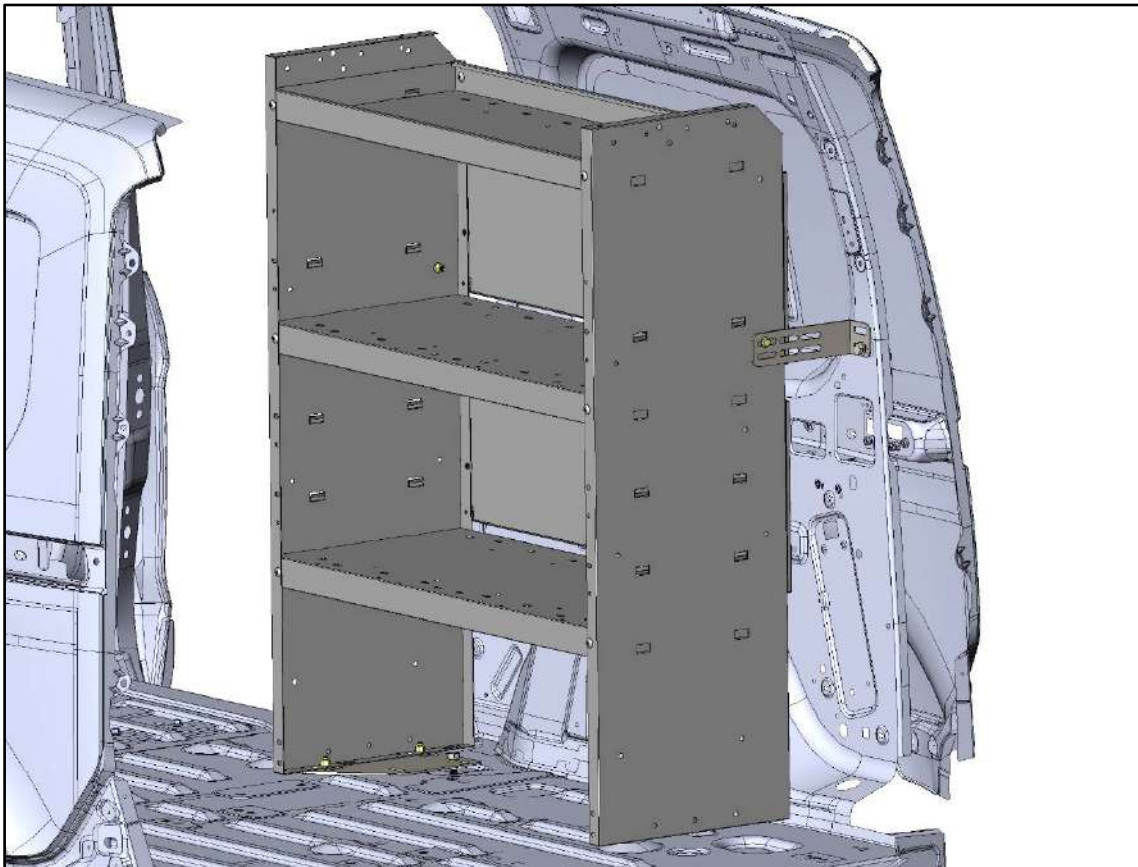



## 4832L Installation Instructions for Nissan NV200/Chevy City Express

**WARNING: LIFT, DO NOT DRAG THE SHELF UNIT INTO POSITION**

### Step 1

- Assemble 4832L without mounting brackets

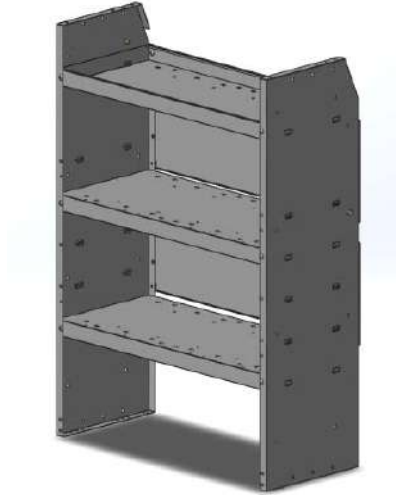

### Step 2

- Remove one D-Ring from floor of van located in the rear of the sliding door on the passenger side.
- Remove another D-Ring from the rear of the vehicle on the passenger side near the back doors.

\*\* Keep bolts



D-Ring locations



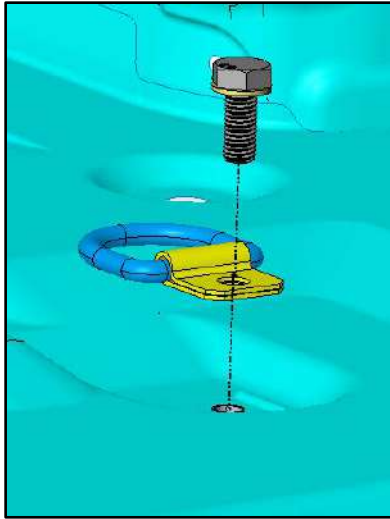

**Step 3**

- Align 4016L-43-001 (bracket)(3) to the shelving unit. Using one 5/16" carriage bolt (D), one 5/16" flat washer(E) and one 5/16" nyloc nut(F).
- Bolt through the middle hole on the base of the shelf support.

**HAND TIGHTEN ONLY**

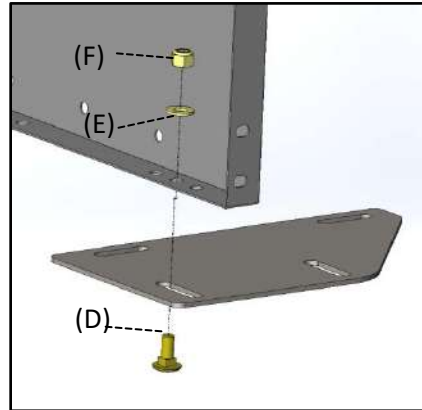
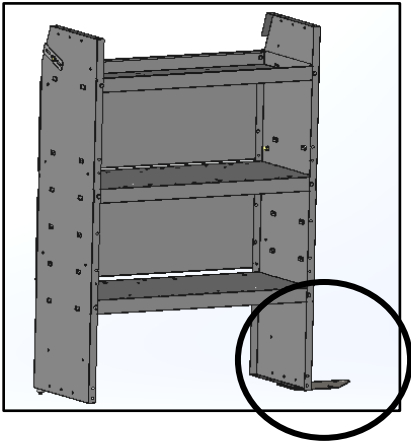

**Step 4**

- Place shelving unit in rear of van on the passenger side behind the sliding door. Align large hole in the back of the shelf support with the weld nut attachment from removing the D-Ring. This location is closest to the sliding door.
- Use one M10 lock washer (B), one M10 flat washer (C) and one 3/8" spacer (G) and bolt D-Ring bolt back into the weld nut.

\*\*The spacer is placed under the shelf.

**HAND TIGHTEN ONLY**

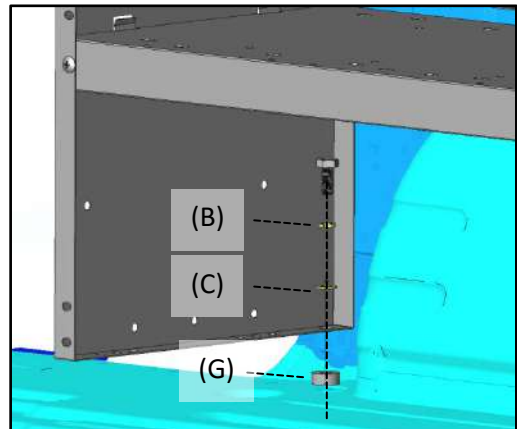
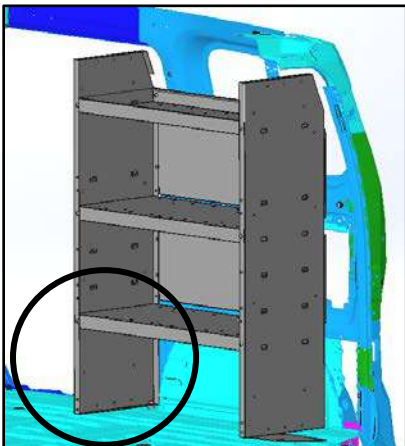

### **Step 5**

- Bolt 4016L-43-006 (7) to the upper rear weldnut using a M8 hex head bolt (O), one lock washer (U) and one flat washer (E).  
Bolt 4016A-43-006 (7) to the shelf using 1/4" hex head bolt (I), with two flat washers (J), and one 1/4" nylock nut (K)

**HAND TIGHTEN ONLY**

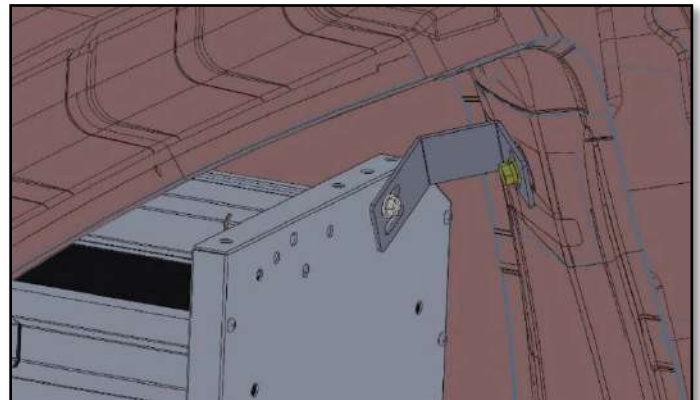
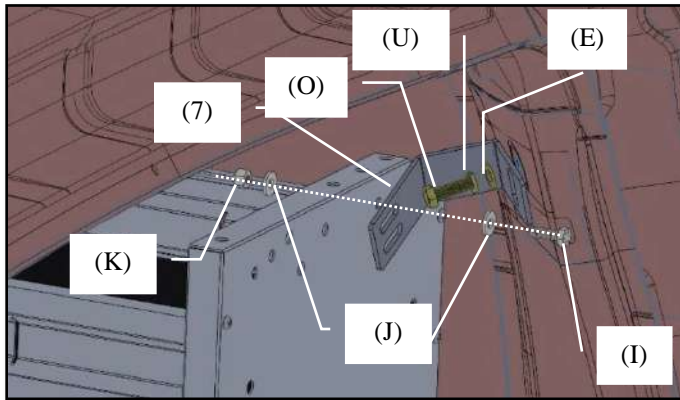

### **Step 6**

- Align far right slot on 4016L-10-005 (bracket) (4) to the embossed hole on the panel near sliding door. Attach bracket to the panel using one M8 x 25 Hex bolt(O), one 5/16" lock washer(U) and one 5/16" flat washer(E).

**HAND TIGHTEN ONLY**

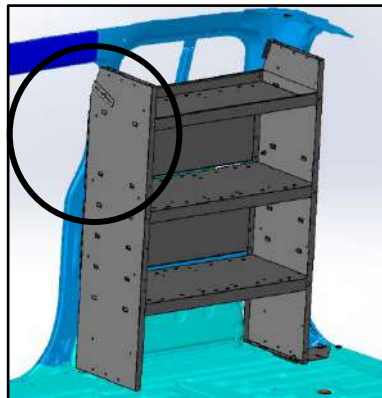
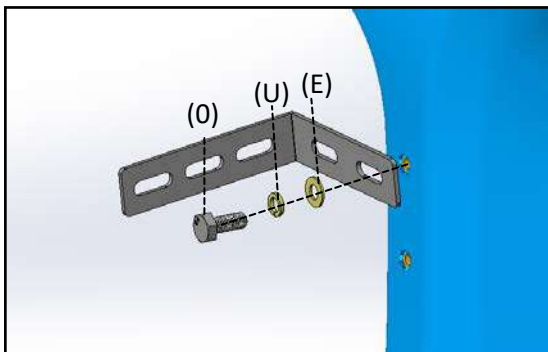

### **Step 7**

- Align middle slot on 4016L-10-005 (bracket)(4) to the shelf support. Attach bracket to the shelf using one 1/4" bolt(I), two 1/4" flat washers(J) and one 1/4" Nylocnut(K).

**HAND TIGHTEN ONLY**

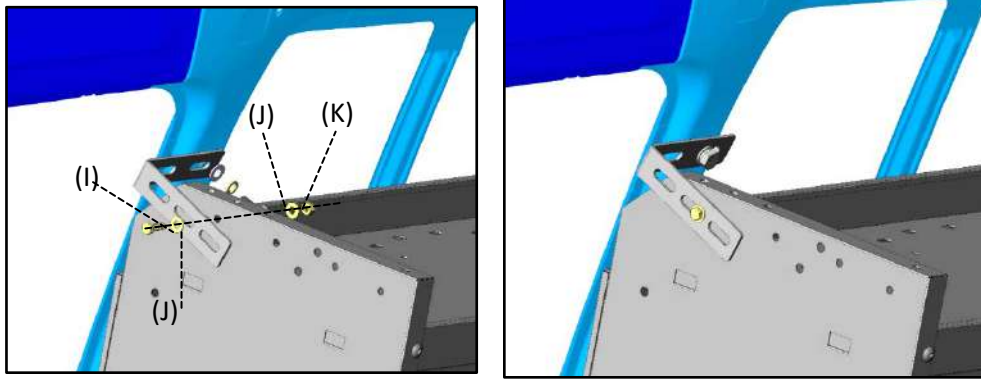

**Step 8**

- Align 4016L-43-001 (bracket) to therear D-Ring mount. Use New M8 x 45mm bolt(P), one 5/16"lock washer (U)and 5/16"flat washer(E) along with 3nylon spacers (G) (as needed) to bolt down 4016L-43-001 (bracket)(3).

\*\*Spacers are underneath bracket**HAND TIGHTEN ONLY**

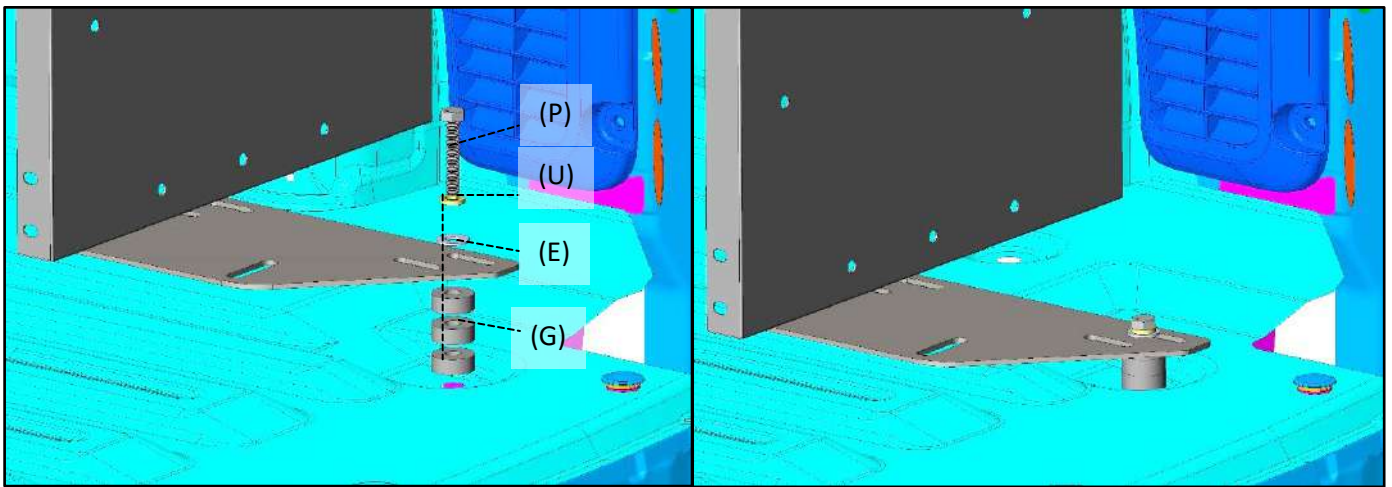

**Step 9**

Level and align shelf. Finish by tightening all nuts and bolts.

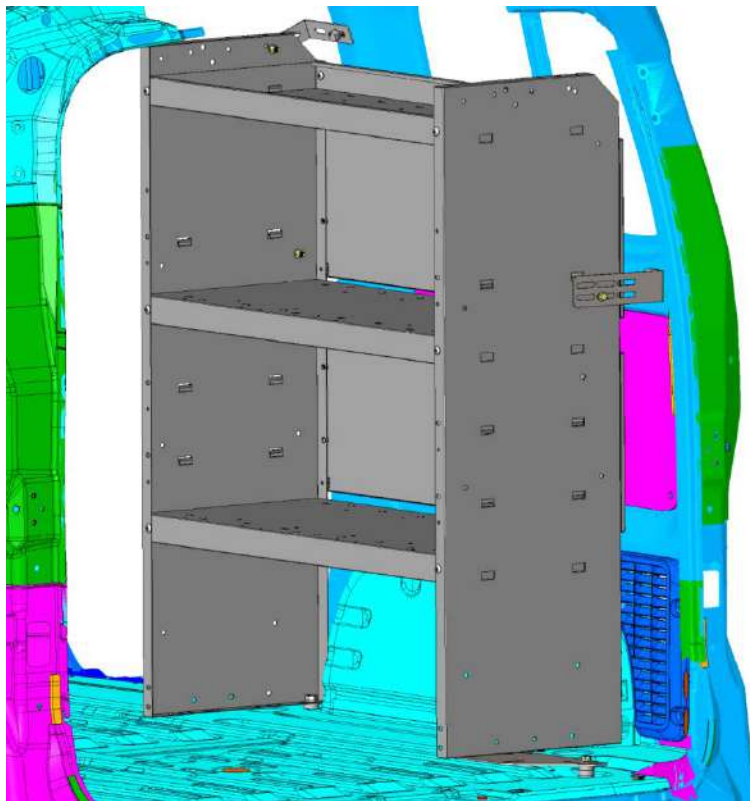



4832L Installation Photos for Ram ProMaster City

**WARNING: LIFT, DO NOT DRAG THE SHELF UNIT INTO POSITION**

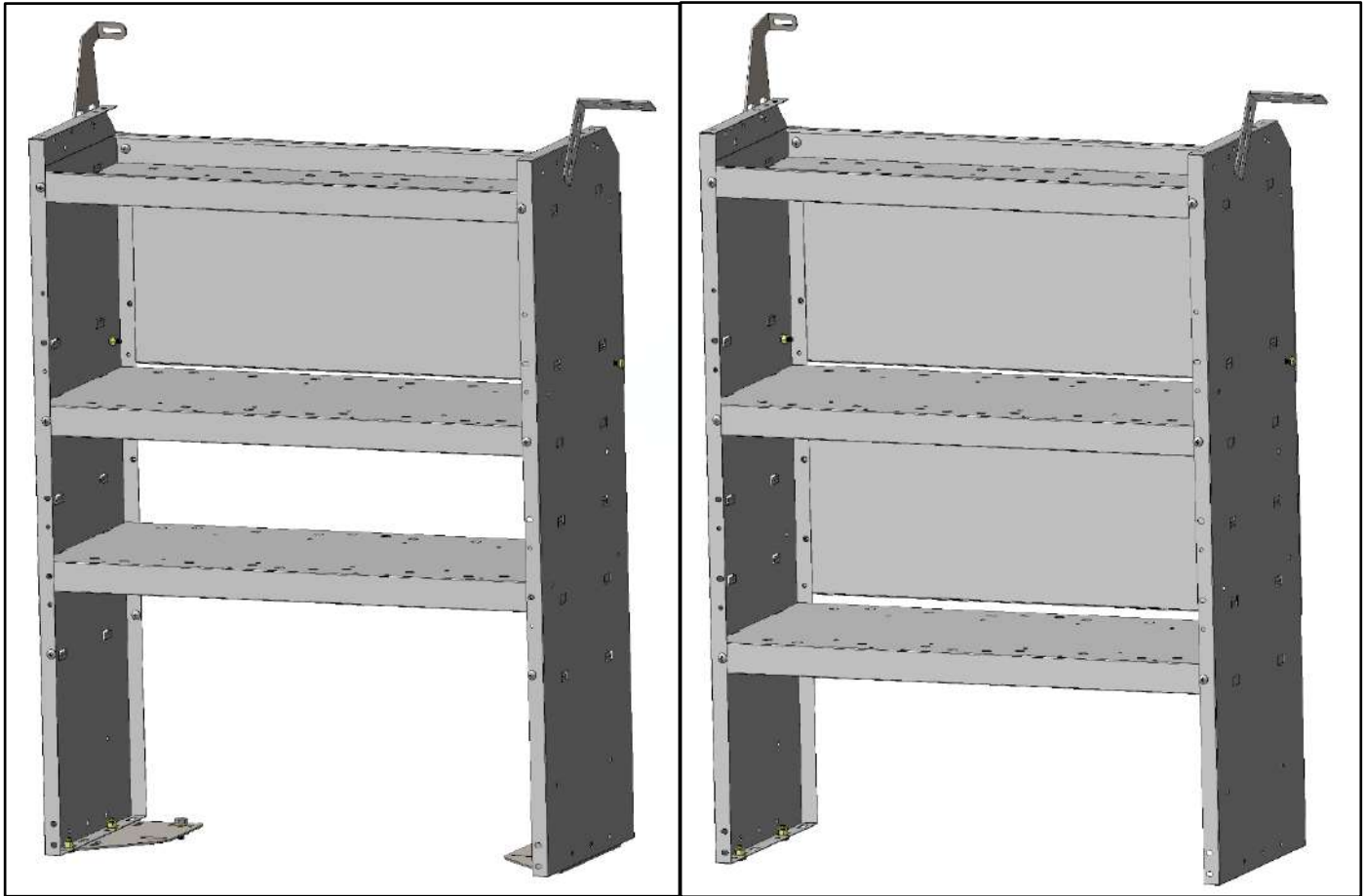

**Option 1:** Bottom Shelf up 1 location, lower “Back Panel” removed. “4016L-43-001” plates mounted to the bottom of the shelf allowing the shelf to be offset from the “D” rings. Allows shelf to be moved closer to the wall giving more aisle room.

**Option 2:** Bottom Shelf on bottom location, lower “Back Panel” in place. 4832L mounts directly to “D” rings. Allows Kargo Master Drawer units to be mounted to the bottom shelf.

### **Step 1**

Remove D-Rings that are to the front and rear of the wheel well from floor of van and place 4832L Shelfover threaded location and mount using M6x25MM bolt (R) with a flat washer (J), lock washer (M) and spacer (G) as shown.

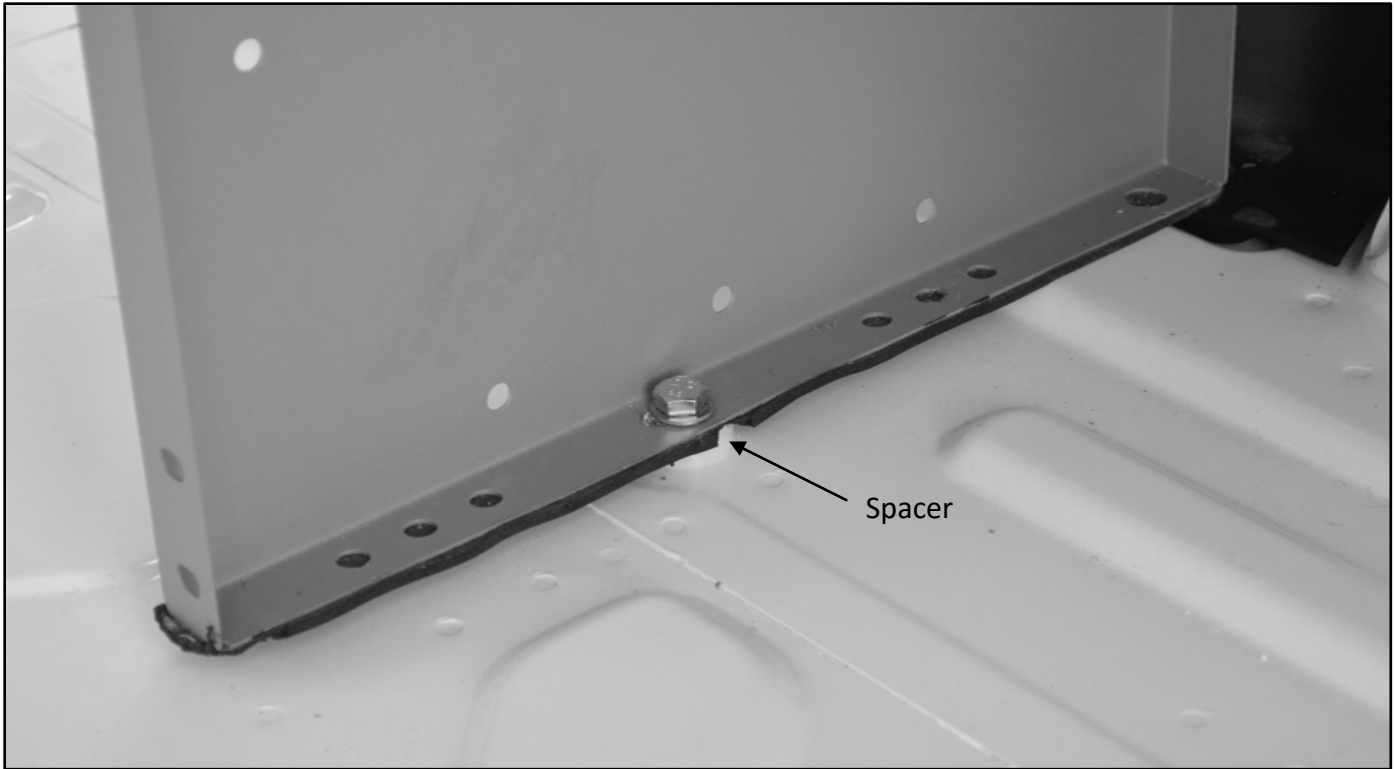

### **Step 2 (Optional)**

If you would like to offset the 4832L Shelf to the front or rear, attach 4016L-43-001 (bracket) to the bottom side of the “Shelf Side” using two 5/16” x 3/4” carriage bolt(D), two 5/16” flat washers(E), two 5/16” Nyloc nuts(F) in the order shown below. Repeat Step 1 to secure the bracket to the floor.

**WARNING: HAND TIGHTEN ONLY UNTIL UPPER MOUNTING BRACKET AND FINAL POSITION IS AQUIRED**

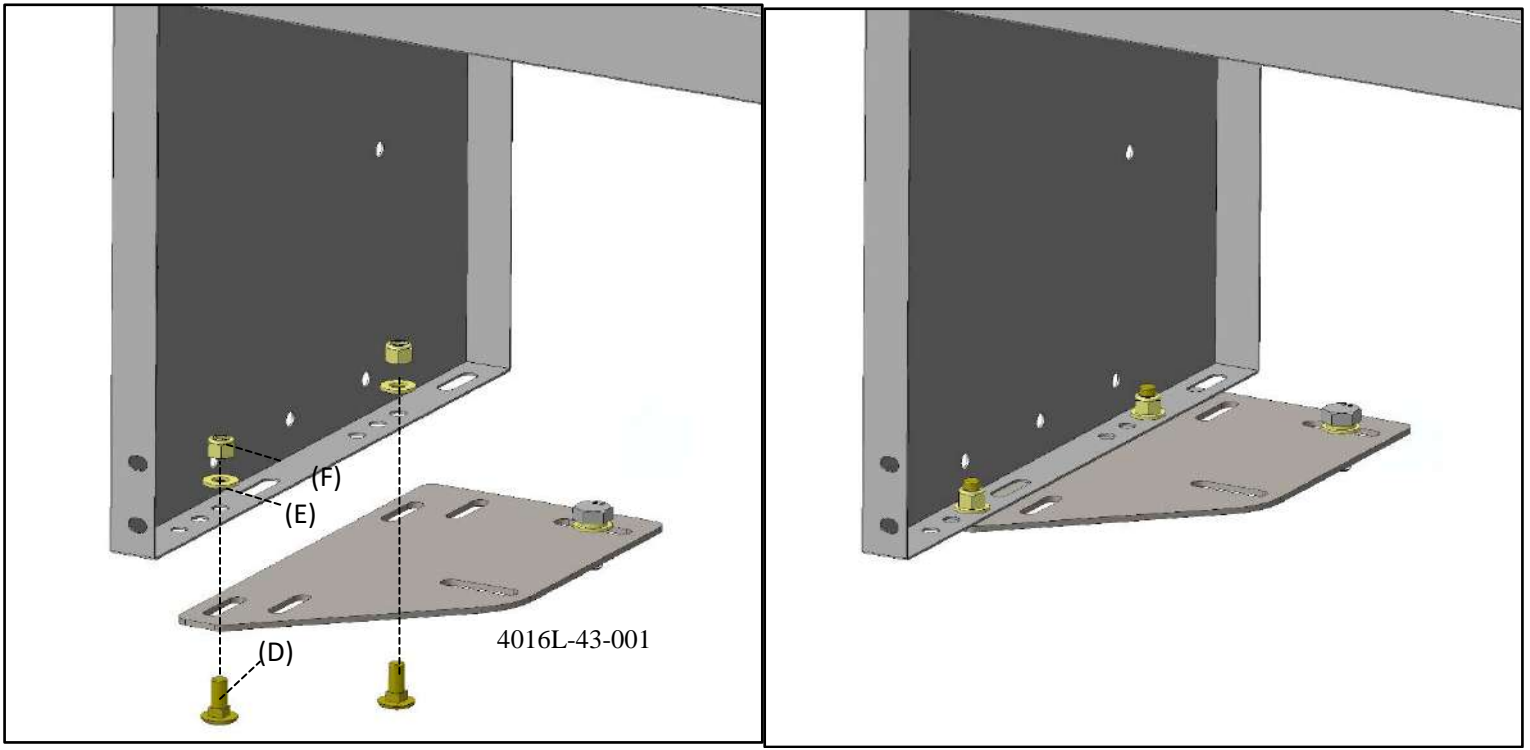

### Step 3

Use the “4016L-10-005” to mount the upper rear of the shelf using  $\frac{1}{4}$ ”x $\frac{7}{8}$ ” bolts(I) with  $\frac{1}{4}$ ” flat washers(J) and  $\frac{1}{4}$ ” nyloc nuts(K) as shown (the picture shows a 46” high shelf-your shelf is 43” high, use the lower slot to accomadate)

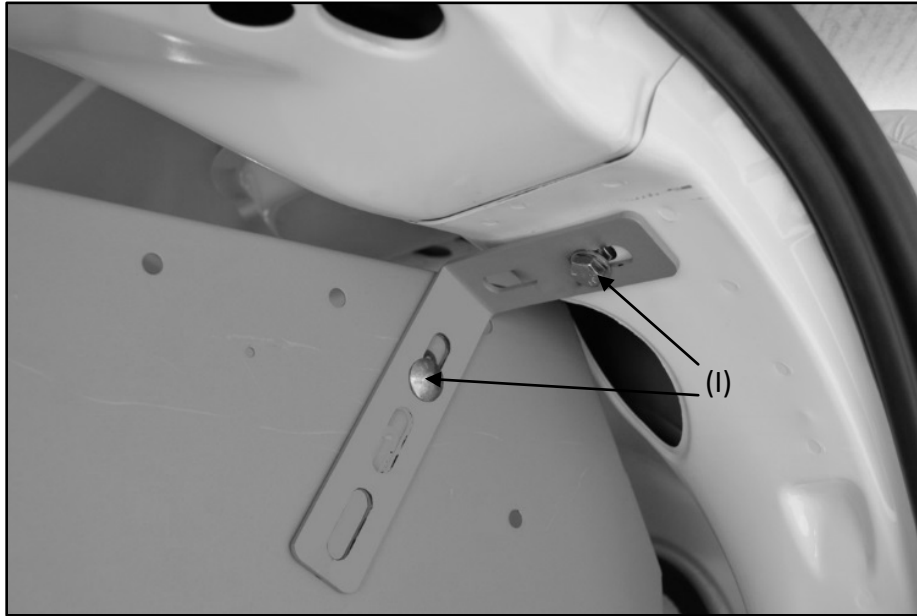

Optional: The “4016L-43-004L” will require drilling but is not necessary (use for added support) for mounting the 4832L Shelf as shown below.

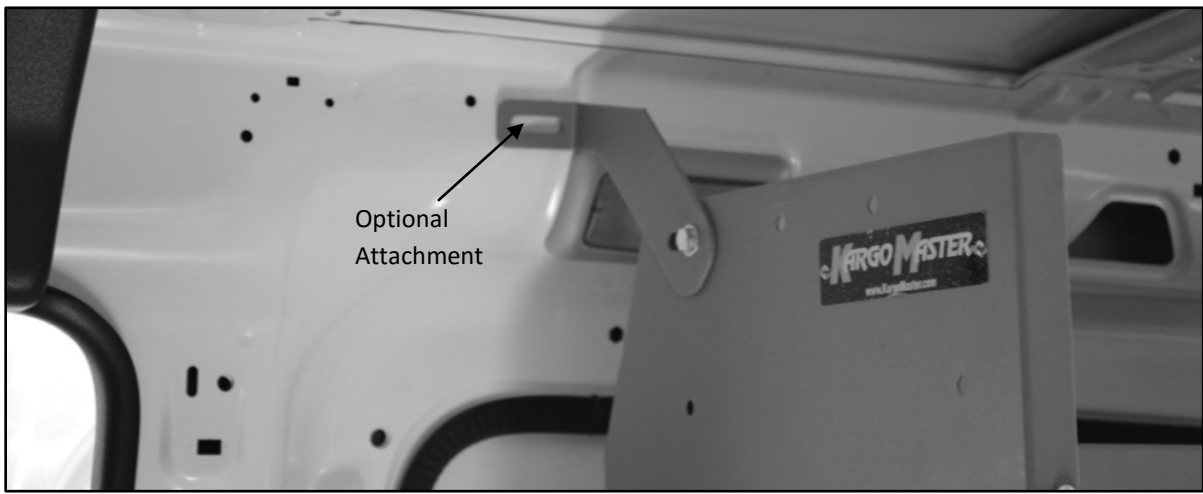

The “4016L-43-003” is used on the front side of the shelf and mounted to the factory M8 stud on the wall of the van, as shown below.

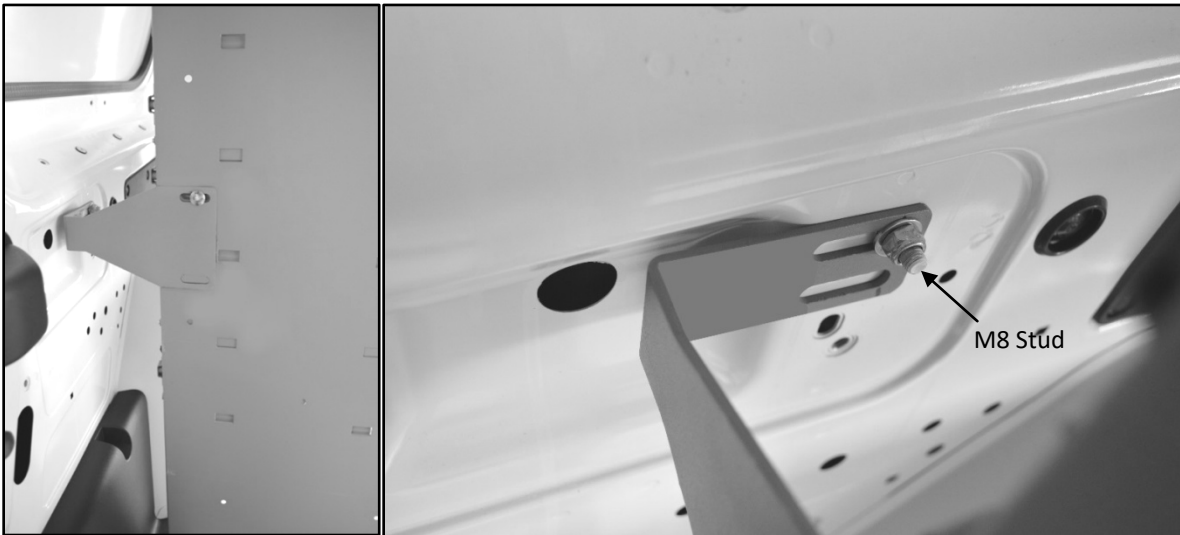

**Level and align shelf. Finish by tightening all nuts and bolts.**  
**(Shown with 4832M-46”high, 4832L is 43” high)**



Make the most out of your vehicle with Kargo Master. Check out the commercial van equipment we offer.