

KARGO MASTER®

WE PUT EVERYTHING WITHIN REACH.

Instruction Guide

48522

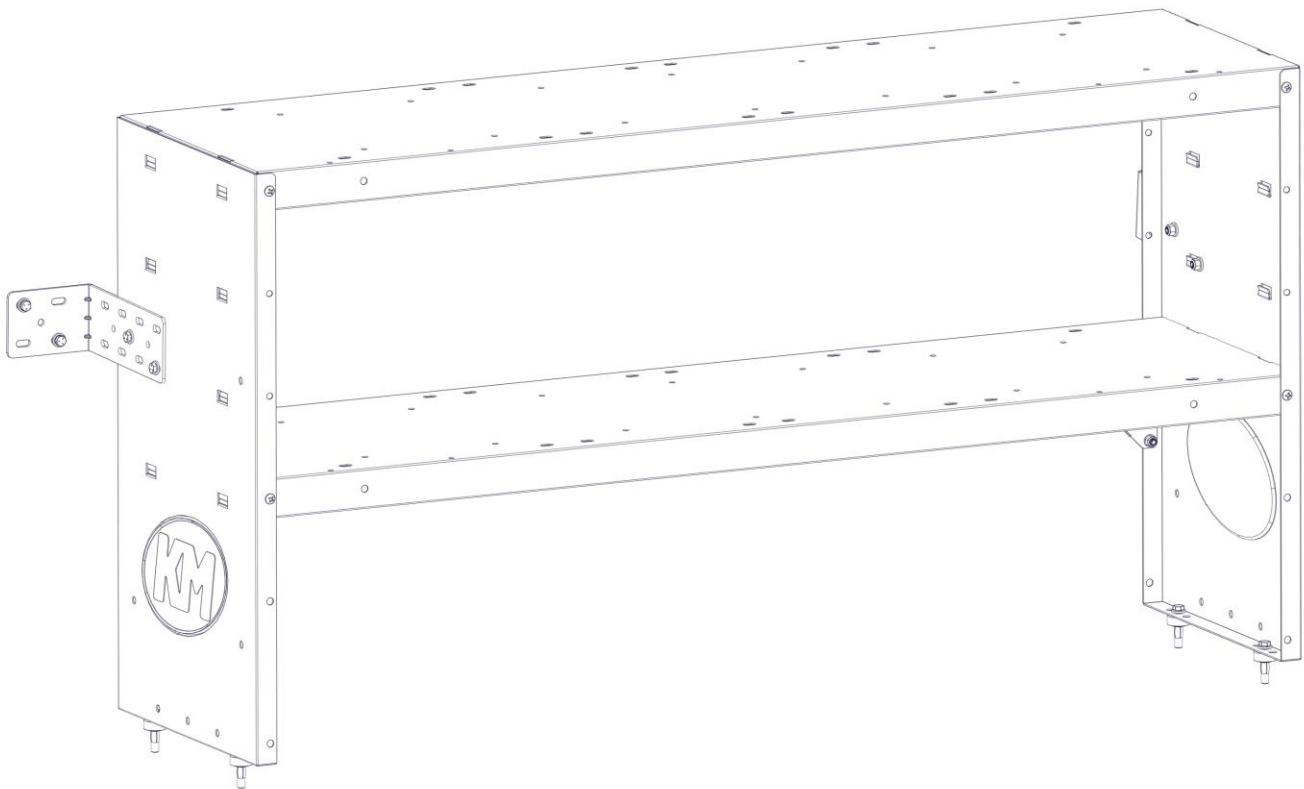

*PLEASE READ ALL INSTRUCTIONS AND WARNINGS PRIOR TO ASSEMBLING,
INSTALLING, AND USING THIS PRODUCT*

Warning



Always check for wires, fuel tanks and lines, brake lines and other important vehicle functionality items prior to drilling and installing all products.

Tools Needed

Phillips Driver	7/16" Socket and Wrench
-----------------	-------------------------



Before You Begin

- Read all instructions.
 - Instructions shown below are using 42" Wide shelf. The instructions are the same on the 32" W, 42" W and 52" W shelves.
 - **ENSURE SAFETY WHILE DRILLING INTO VEHICLE.**
 - **FOLLOW 4869 INSTALLATION INSTRUCTIONS FOR INSTALLATION INTO VEHICLE.**
-

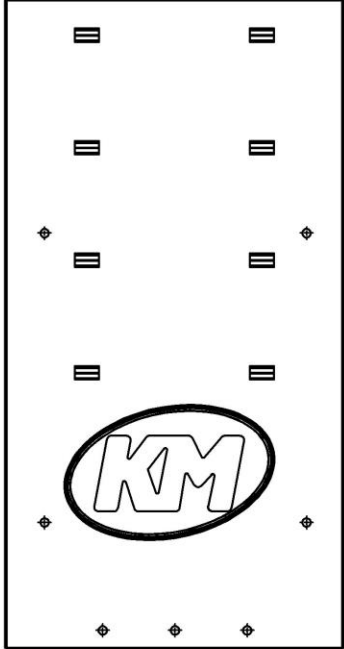
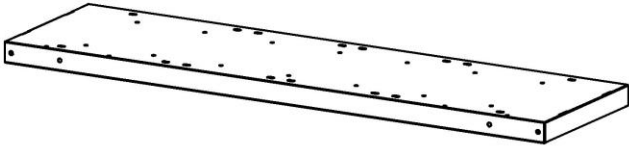
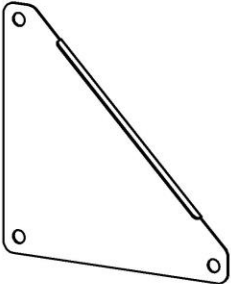
Parts

ITEM NO.		PART NO.	DESCRIPTION	QTY.
A		48027-10-001	27"H SIDE	2
B		48052-10	52" SHELF ASM	2
C		48000-00-001	GUSSET	2
		4869	MOUNT KIT	1
		18-48022	HARDWARE KIT	1

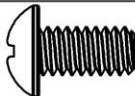
Hardware

ITEM	HARDWARE TO SCALE	PART NO.	DESCRIPTION	QTY.
1		90279A537	1/4"-20 X 1/2" PAN HEAD	12
2		93298A110	1/4"-20 FLANGED NYLOC NUT	8

Step 1 – Install Shelves

- Determine shelf installation locations. Typically, the bottom shelf goes on the bottom lance in the side panel.
- The bottom location is typically used when installing the shelf on top of a wall slide.
- Shelves can be assembled with flanges pointing up to retain shelf contents, or flanges pointing down to allow the installation of drawer cabinets. Decide which option is best for each shelf before attaching to the side panels.
- The rear flange of the shelf has the slot, while the front of the shelf has the nut pressed into the front flange.

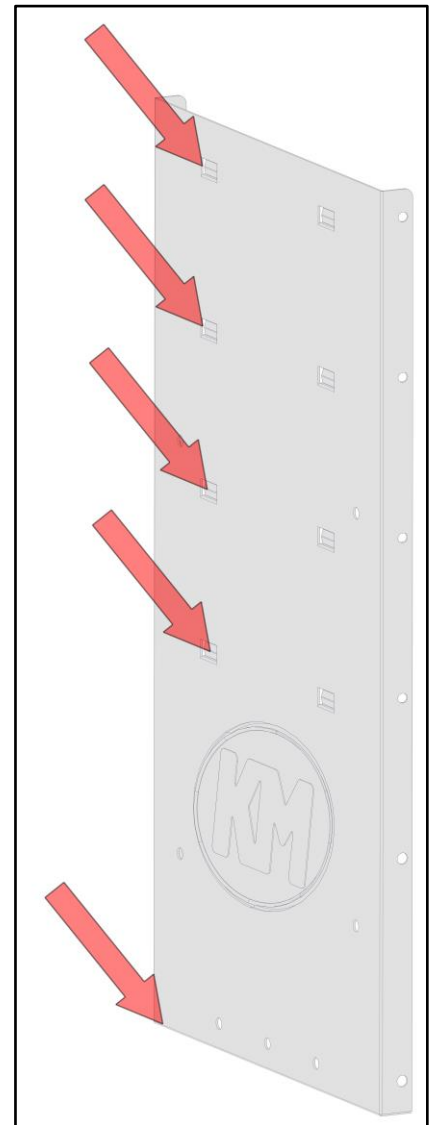

Picture below shows the shelf facing upwards.

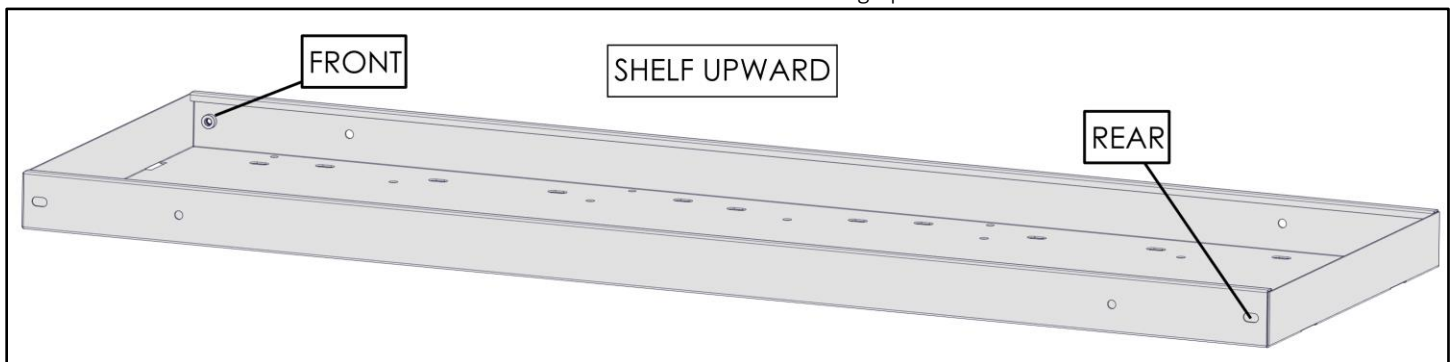

- Make sure the shelf is oriented properly (nuts in front) before attaching. Press the shelf down firmly so it is resting solidly and level on the lances in the shelf sides.
- Most common mounting locations are shown below.

Picture below shows the shelves in a downward position.

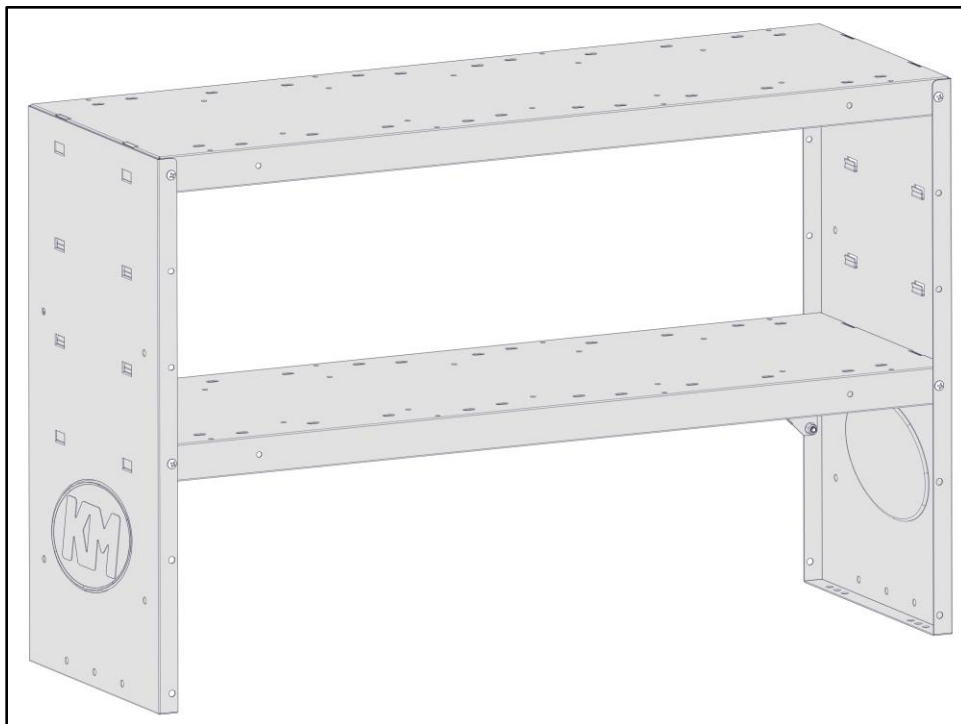
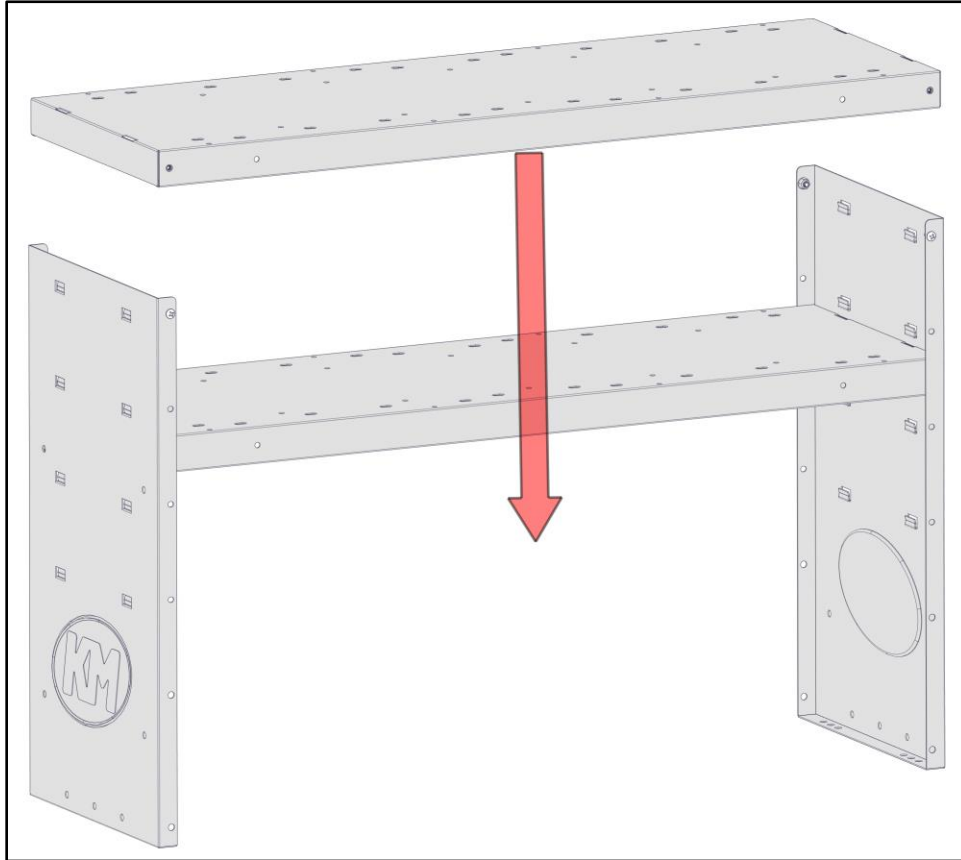

Step 2 – Install Front Hardware

- Attach the front side of both shelves using 1/4" x 1/2" pan head screws.
- Repeat on both sides.

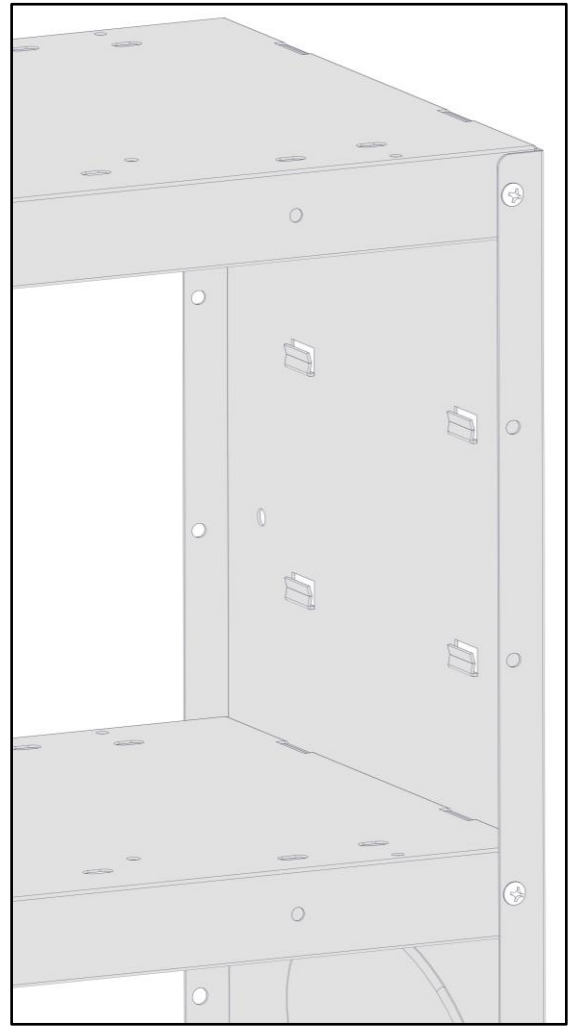
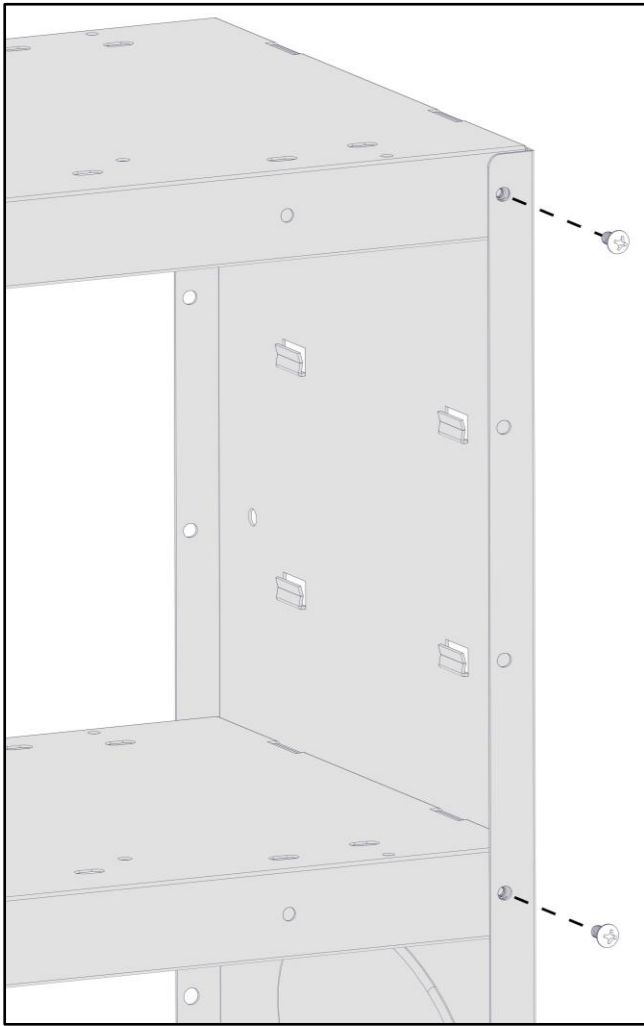

Step 3 – Install Support Gussets

- If installing the bottom shelf on the bottom lance, use the support gussets. If no gusset is being installed, skip to the next step.
- At the rear of the shelf, slide the **gusset** between the side panel and the previously installed shelf so that the flange on the gusset is towards the inside of the shelf.
- Bolt the gusset, the shelf and the side panel together using 1/4" x 1/2" pan head screws and 1/4" flanged nyloc nuts.
- Repeat on both sides.

Backside of shelf shown below

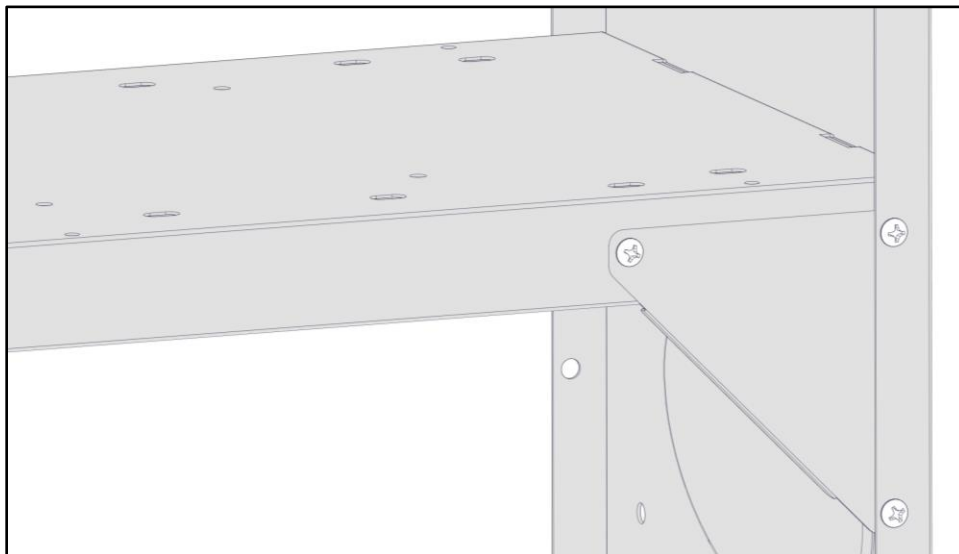
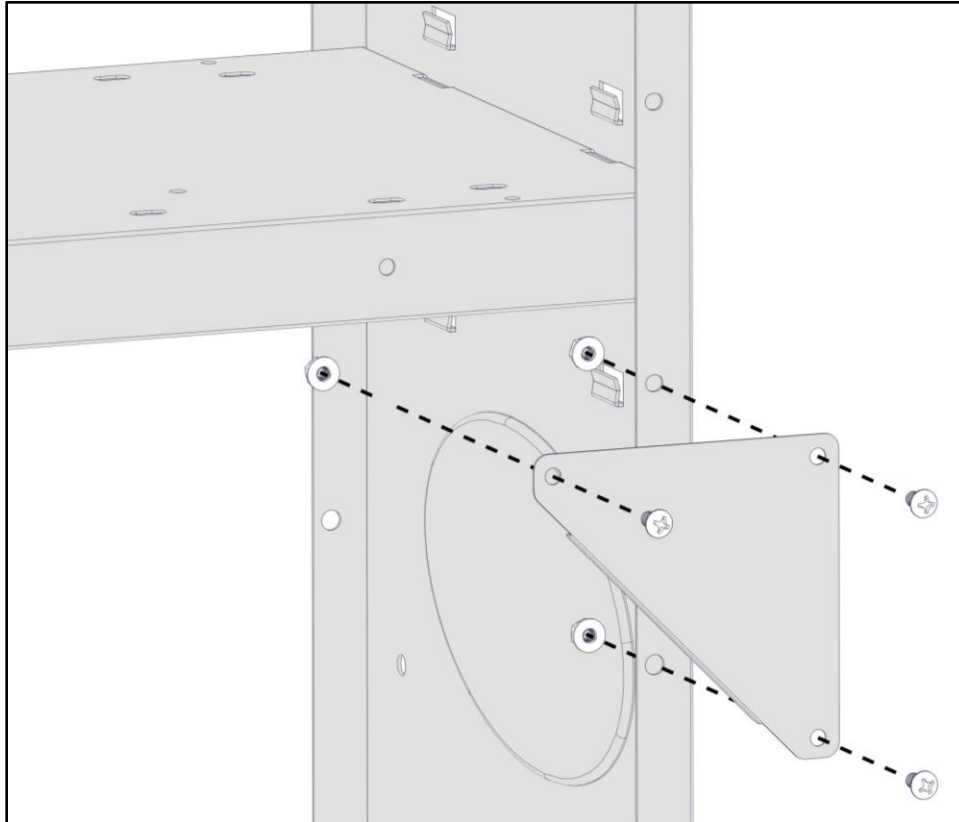

Step 4 – Install Remaining Hardware

- Attach the rear of the shelves to the side panels using 1/4" x 1/2" pan head screws and 1/4" flanged nyloc nuts.
- See previous step if a gusset is being installed.
- Repeat on both sides.

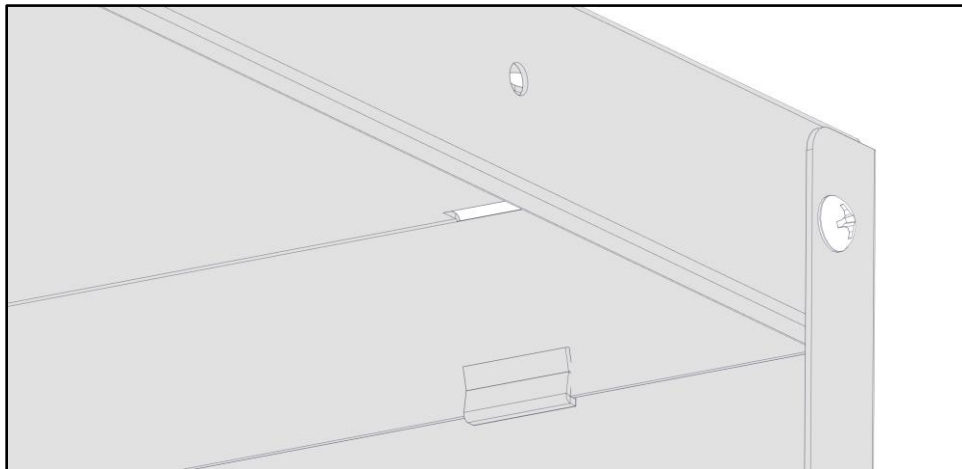
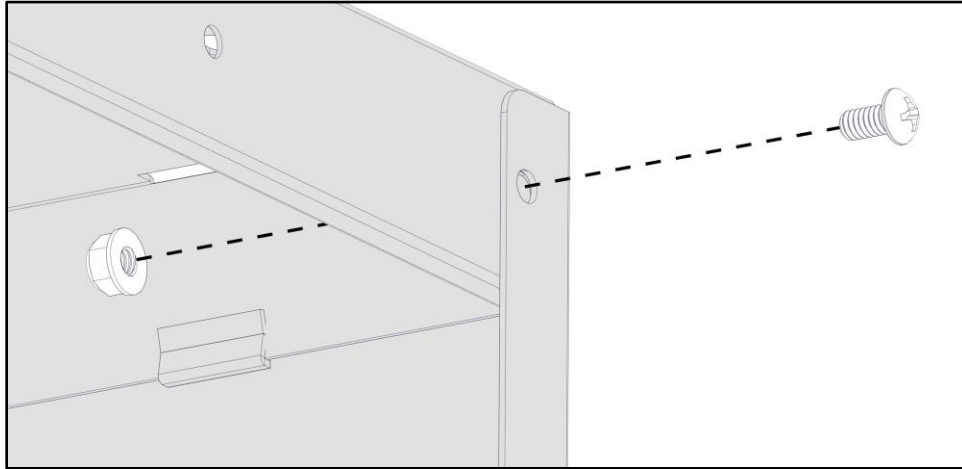

Follow instructions from the
mount kit to complete
installation.

Assembly is now complete.





WE PUT EVERYTHING WITHIN REACH.

Instruction Guide

40532

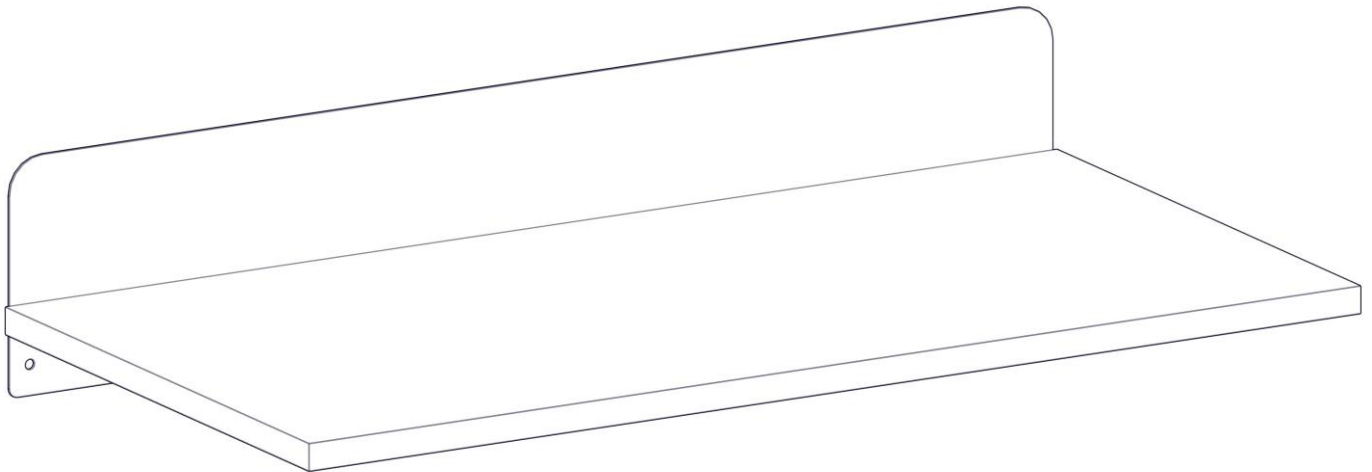

*PLEASE READ ALL INSTRUCTIONS AND WARNINGS PRIOR TO ASSEMBLING,
INSTALLING, AND USING THIS PRODUCT*

Warning



Always check for wires, fuel tanks and lines, brake lines and other important vehicle functionality items prior to drilling and installing all products.

Tools Needed

Phillips Driver

Before You Begin

- Read all instructions.
 - Be sure to have a shelf unit to attach bench kit to.
-

Parts

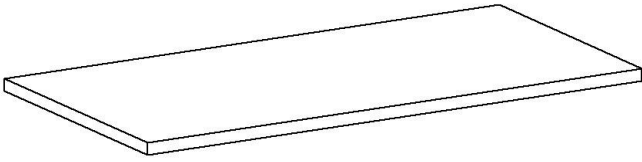
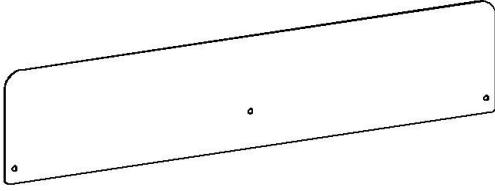
ITEM NO.		PART NUMBER	DESCRIPTION	QTY.
A		100571	BENCH TOP - 32"	1
B		48320-00-001	BACK SPLASH - 32"	1
		18-40552	HARDWARE	1

Hardware

ITEM NO.	TO SCALE	PART NUMBER	DESCRIPTION	QTY.
1		90398A244	No.10 x 5/8" Round Head Screw	5

Step 1 – Assemble Shelf

- Have desired shelf unit built. Be sure the top shelf is on the highest notch and oriented with shelf lip down as shown.

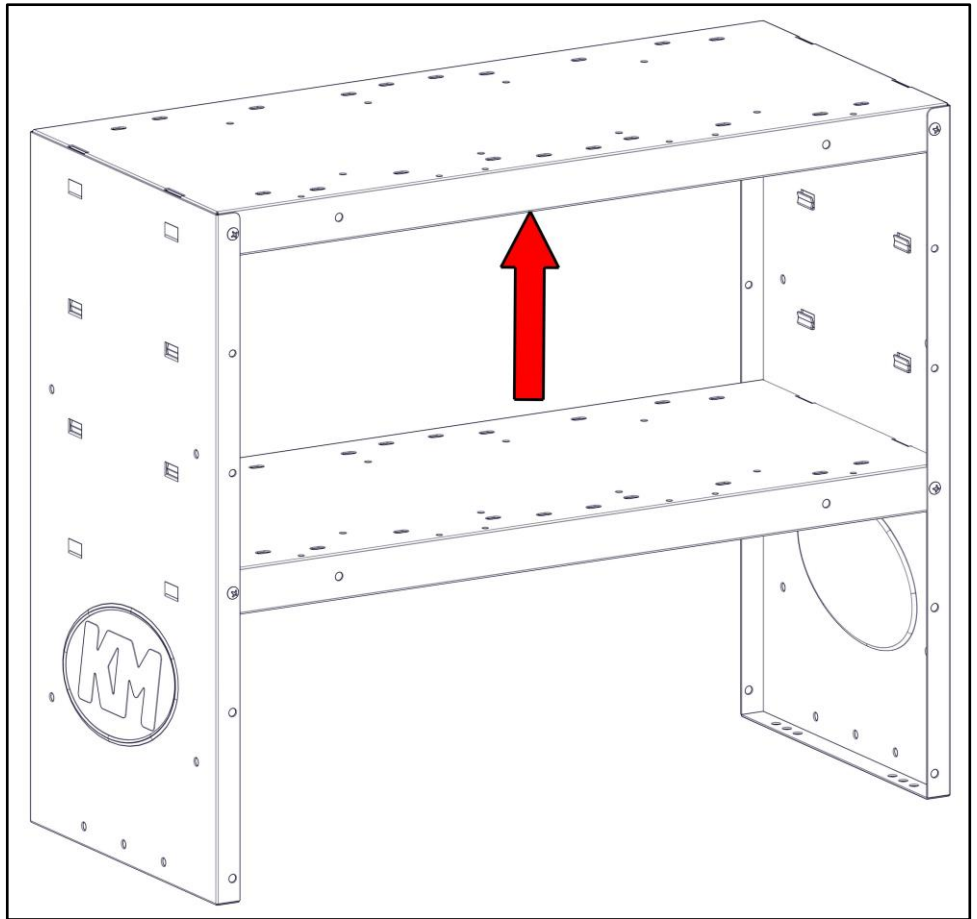

Step 2 – Prepare Shelf Unit

- Access rear of shelf unit. Rear of shelf unit has gussets installed on the bottom shelf.
- Remove upper screws attaching top shelf to side panels as shown.

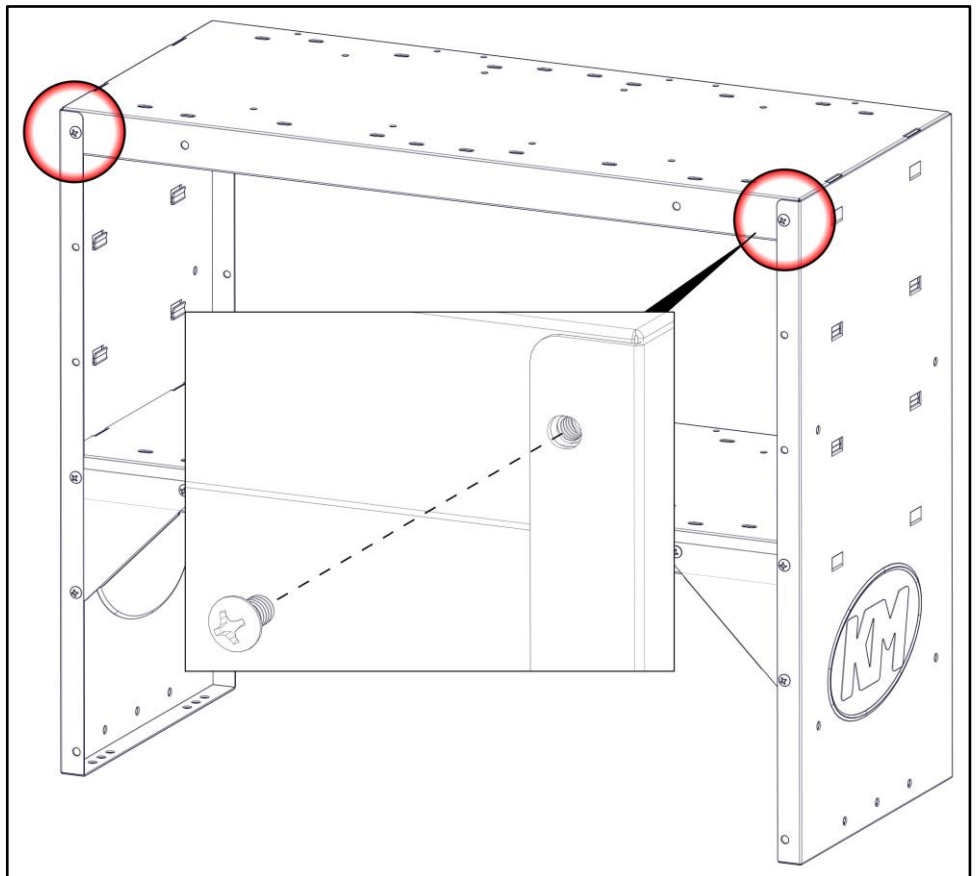

Step 3 – Install Back Splash

- Place back splash over previously removed screws.
- Re-install screws leaving the middle hole in back splash vacant.
- Snug Tighten.

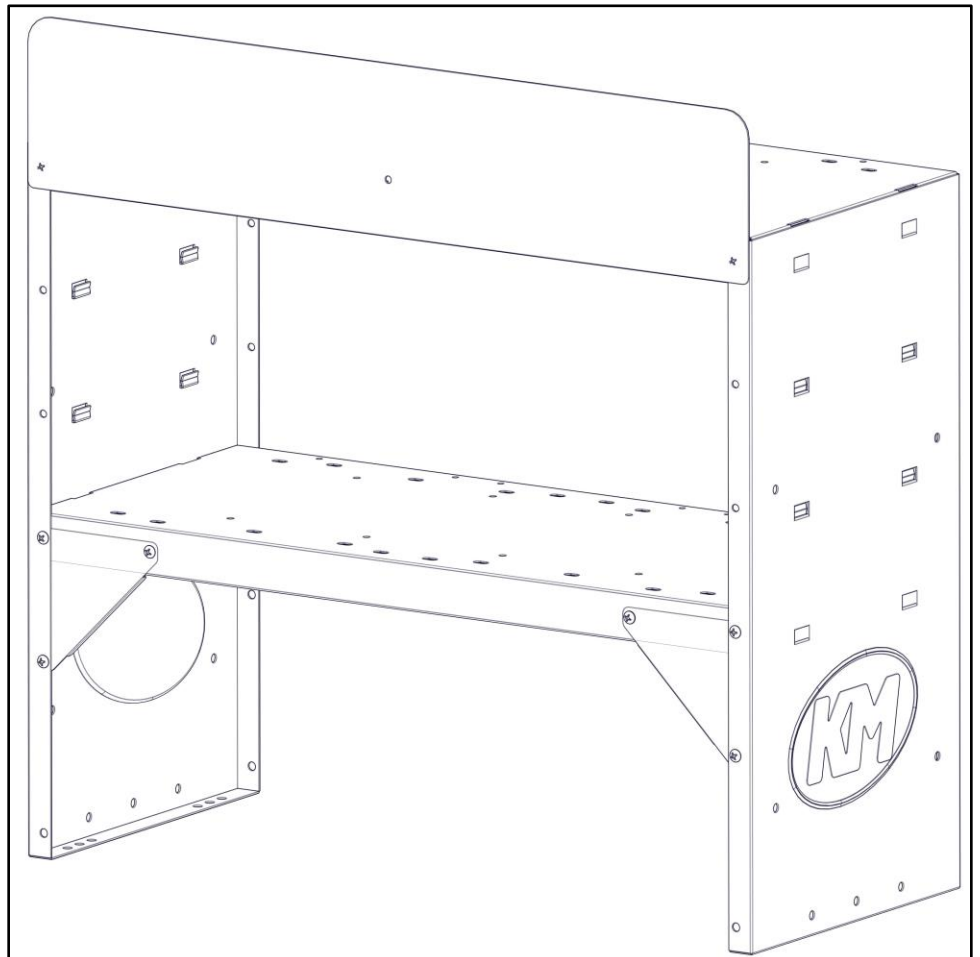
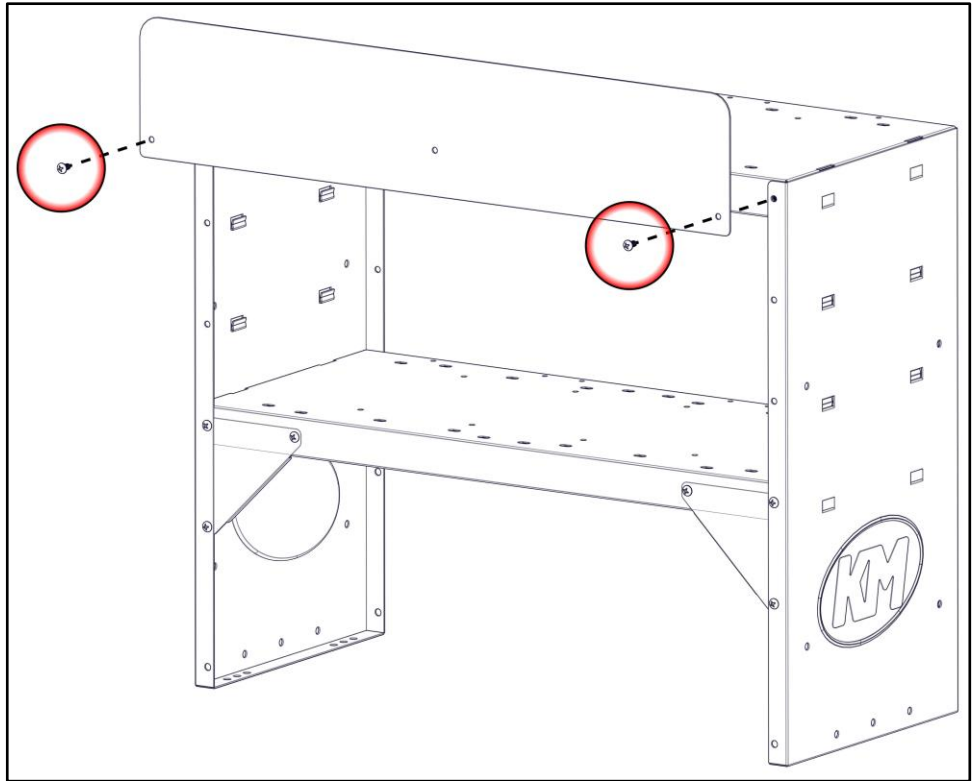

Step 4 – Install Bench Top

- Place bench top on top of shelf as shown. Align bench top to desired location.
- Screw bench top to back splash using a No.10 screw.
- On bottom side of shelf, find four appropriate mounting holes. Screw through these holes into bottom side of bench top using No.10 screws.
- Tighten all screws.

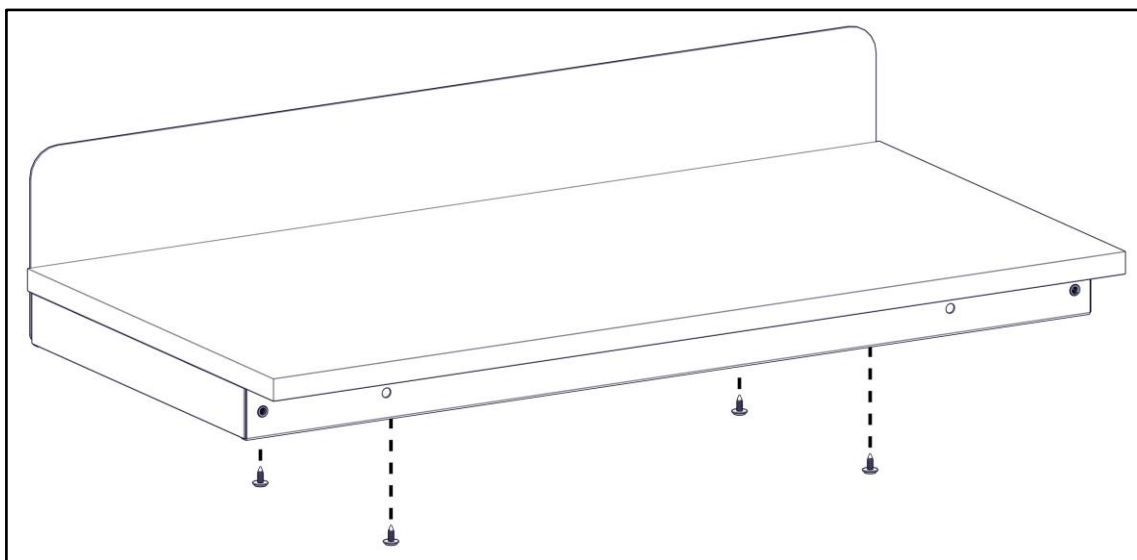
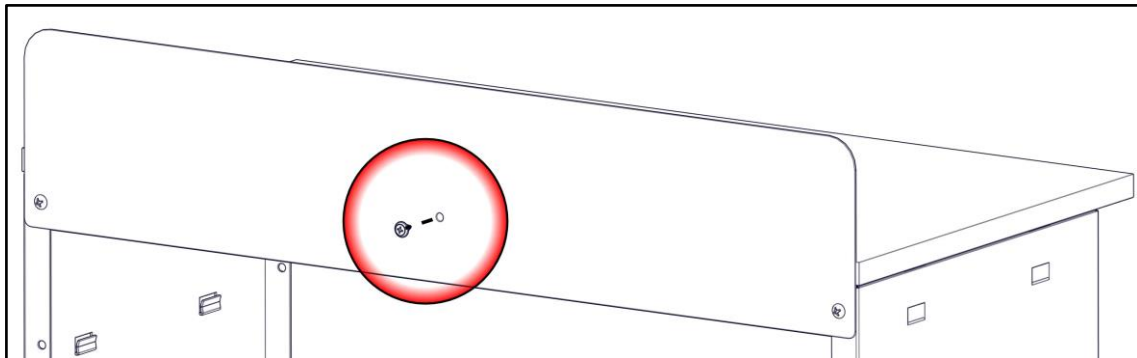
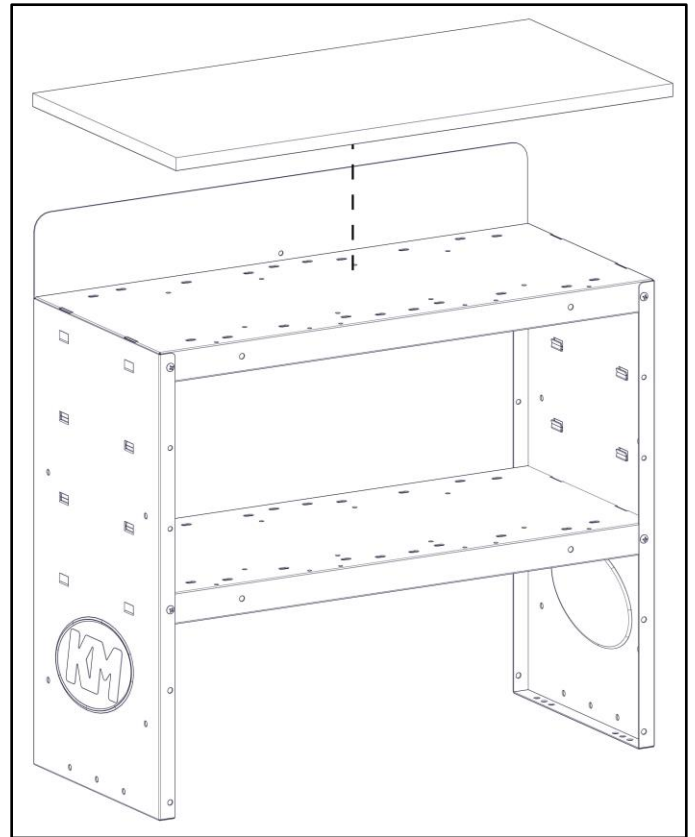

****Only top shelf is shown above for simplicity****

GO BACK AND ENSURE ALL HARDWARE IS TIGHT

Installation is now complete

