

KARGO MASTER®

WE PUT EVERYTHING WITHIN REACH.

Installation Guide

4099H

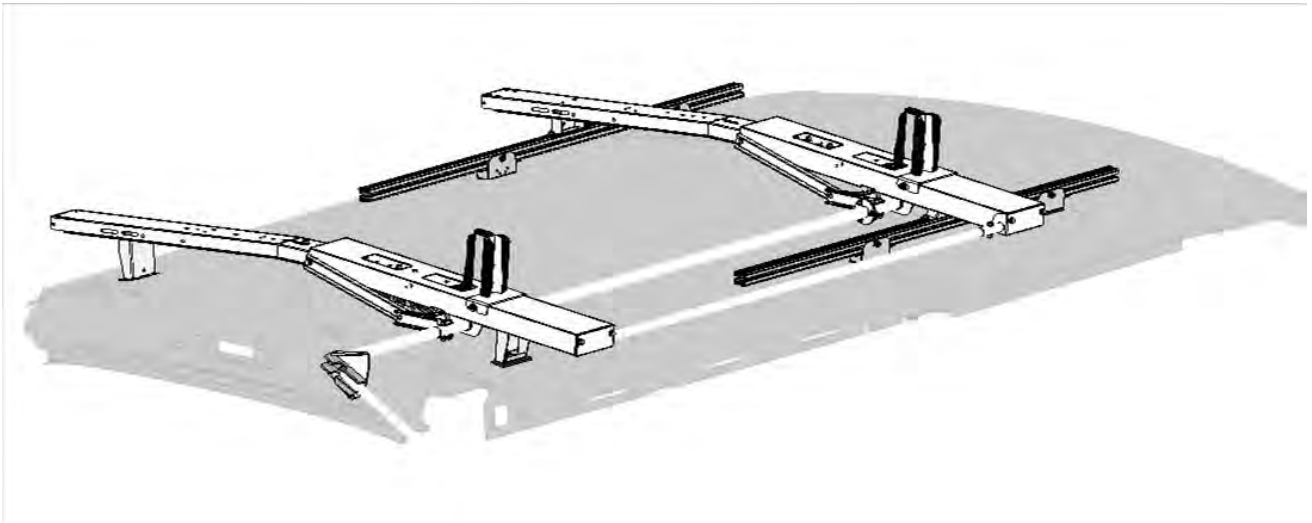

***PLEASE READ ALL INSTRUCTIONS AND WARNINGS PRIOR TO ASSEMBLING,
INSTALLING, AND USING THIS PRODUCT***

Warning



Always check for wires, fuel tanks and lines, brake lines and other important vehicle functionality items prior to drilling and installing all products.

Tools Needed

1/2" Wrench and Socket	7/16" Wrench and Socket
9/16" Wrench and Socket	Tape Measure
Phillips Drive	

Table of Contents

Parts List 2

Hardware List 3

Step 1 Install Actuator 4

Step 2 Install Front and Rear Bow Assembly 5-6

Step 3 Torque Tube 6-7

Step 4 Ladder Pan Support 8

Step 5 Ladder Stops and Hooks 9







Step 6 Install Rack 10

Step 7 Install handle bar clip 11

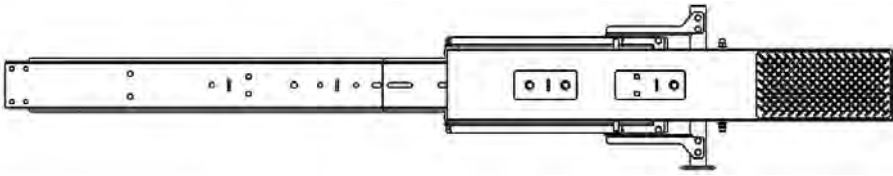
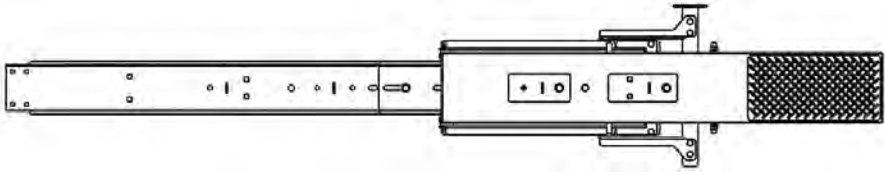

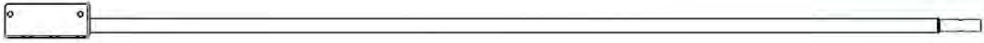
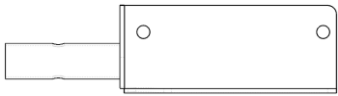
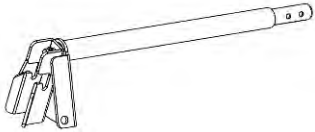

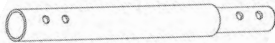
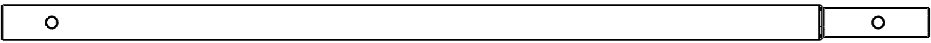

Before You Begin

- Read all instructions.

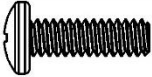
Parts

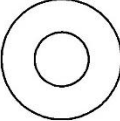
	4099H PARTS	DESCRIPTION	QTY
A		Front Bow Assembly	1
B		Rear Bow Assembly	1
C		Torque Tube	1
D		Support Tube	1
E		Support Tube End	1
F		Actuator	1
G		Removable Handle	1
H		Ladder Hook	2
I		Ladder Stop	2
J		Torque Tube Extender	1
K		Handle Extender	
L		Support Tube Extender	1
		HARDWARE	1

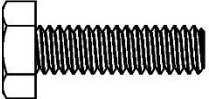
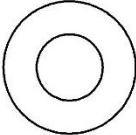
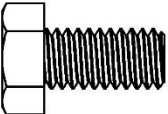
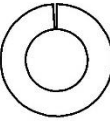
Hardware

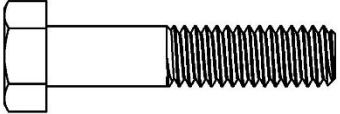
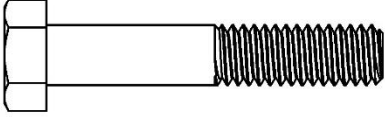
ITEM NO.	TO SCALE	DESCRIPTION	QTY.
1		10-24 x .625 PH Phillips Drive	2
2		10-24 Nyloc Nut	2
3		.25 flat washer	18
4		.25-20 NYLOC NUT	9
5		.25-20 x .875 HH	9
6		.312 Flat Washer	10
7		.312-18 x .625 HH	4
8		.312 Split Lock Washer	4
9		.312-18 Nyloc Nut	3
10		.312-18 x 1.50 HH	1
11		.312-18 x 1.75 HH	2
12		Handle Bar Holder	2
13		E6000	1

Step 1 – Install Actuator

- This can be done on or off the van.
- Remove existing hardware from the Rear Bow Assy. (B) as shown
- Keep Hardware, This will be re-used.
- Install the Actuator (F) with the “triangle” opening towards the end of the bow.
- Be sure to put E6000 into tube swedge and around the bolt holes.

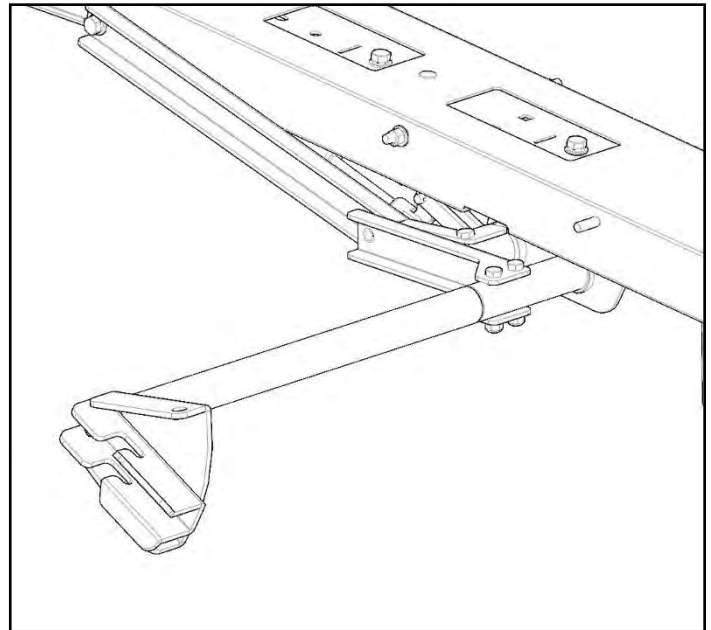
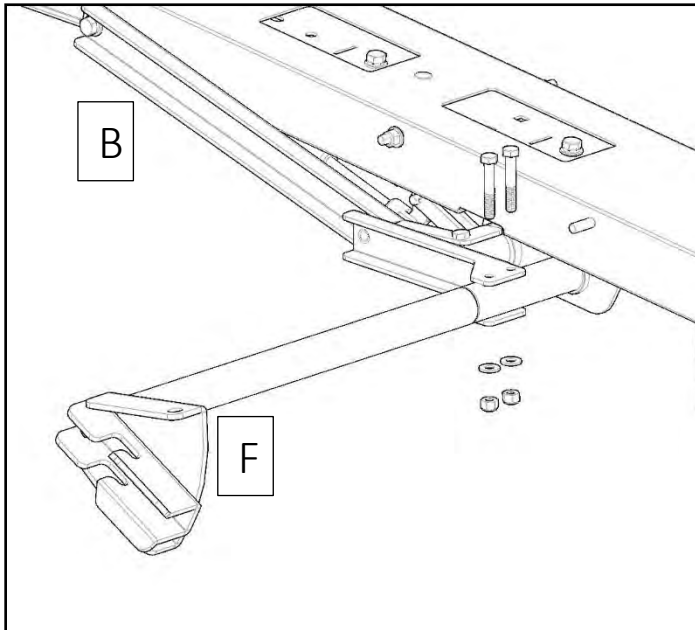

If installing on a High Roof Extended Transit, the Handle Extension (L) will be used. This extension goes inbetween the rear bow (B) and the actuator (F).

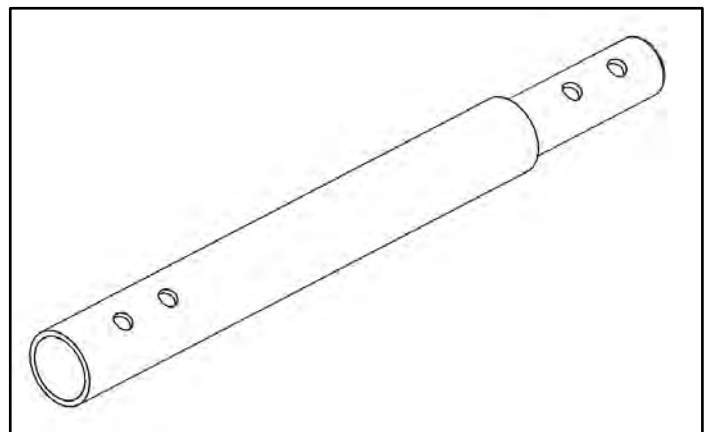

Step 2 – Install Front and Rear Bow

If you have a lift you can skip this step and continue building the rack on a bench

A. Rear Bow

- Set Rear Bow Assy. (B) on rear mounting feet as shown.

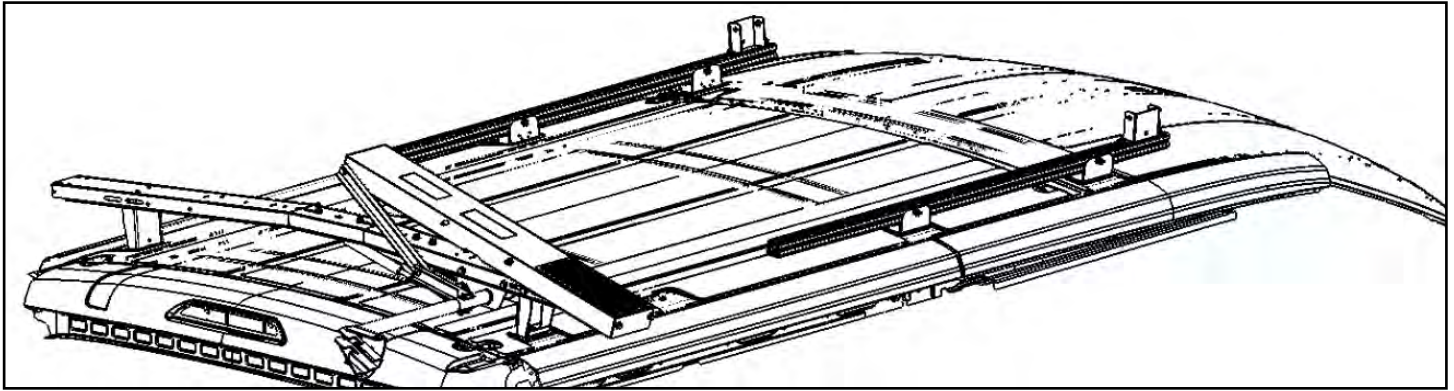

- Place a foam block from the packaging to hold the bow in the up position in order to access the mounting slots.
- Insert .375" x .75" hex head bolts (13) with .375" flat washer (12) and .375" lock washer (11) as shown.
- Leave loose until the the rack is assembled.
- Repeat on other side of bow.

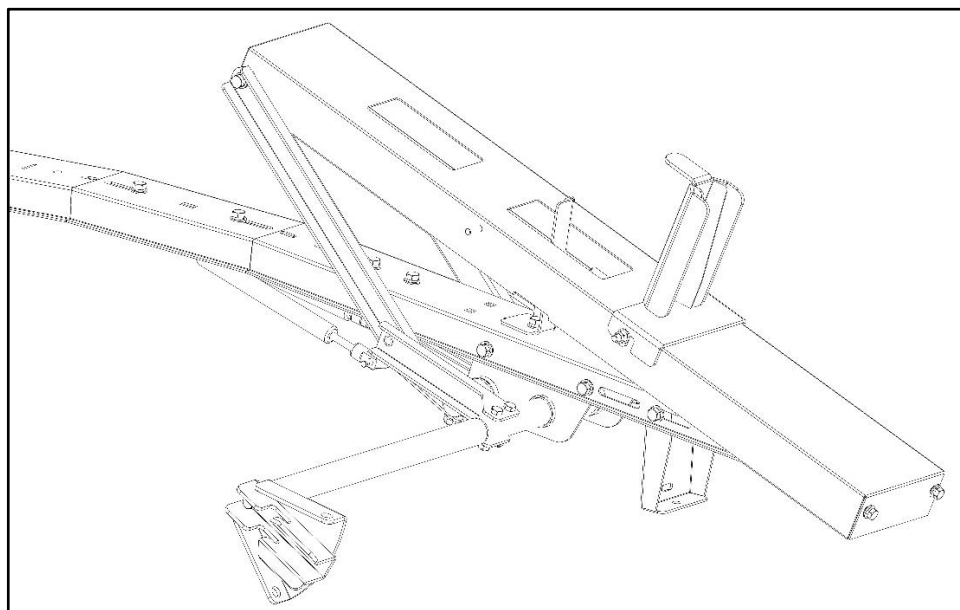
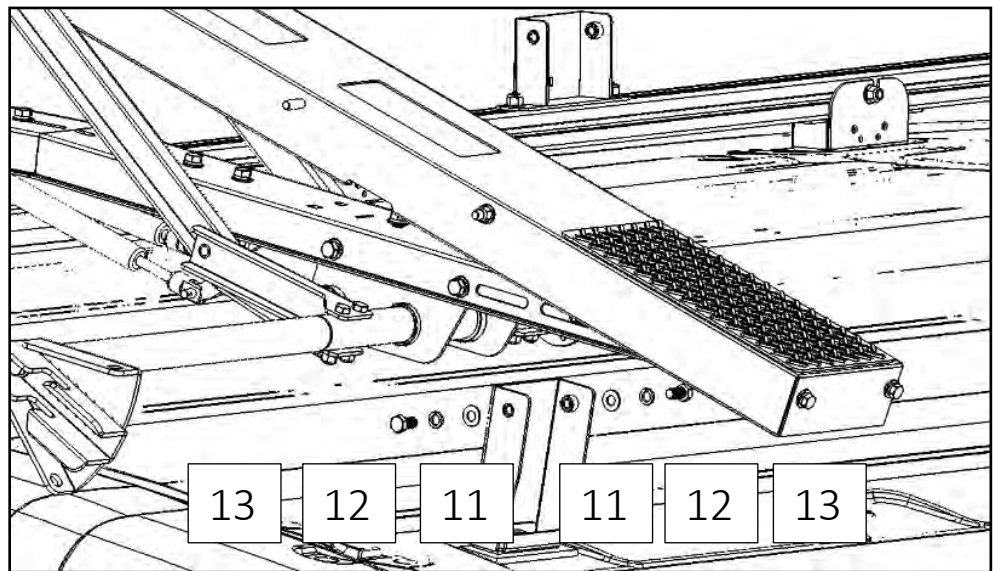

B. Front Bow

- Repeat the process for the front bow (A).

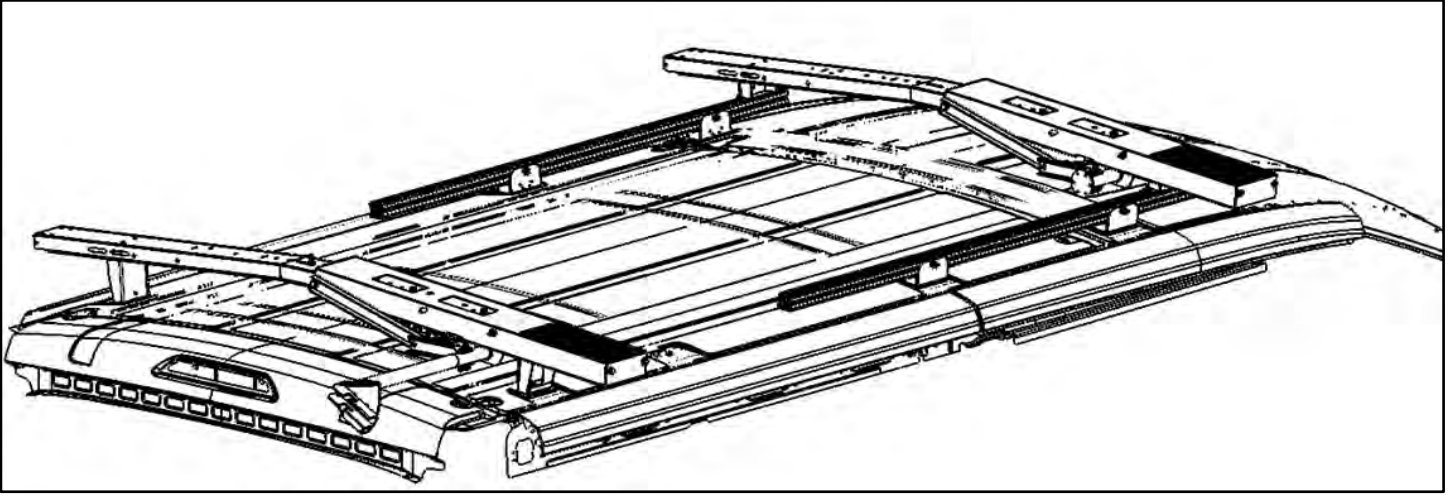

Step 3 – Torque Tube Installation

****BE SURE THE BOTH FRONT AND REAR LADDER PANS ARE ALL THE WAY DOWN ON THE BOWS WHILE TIGHTENING****

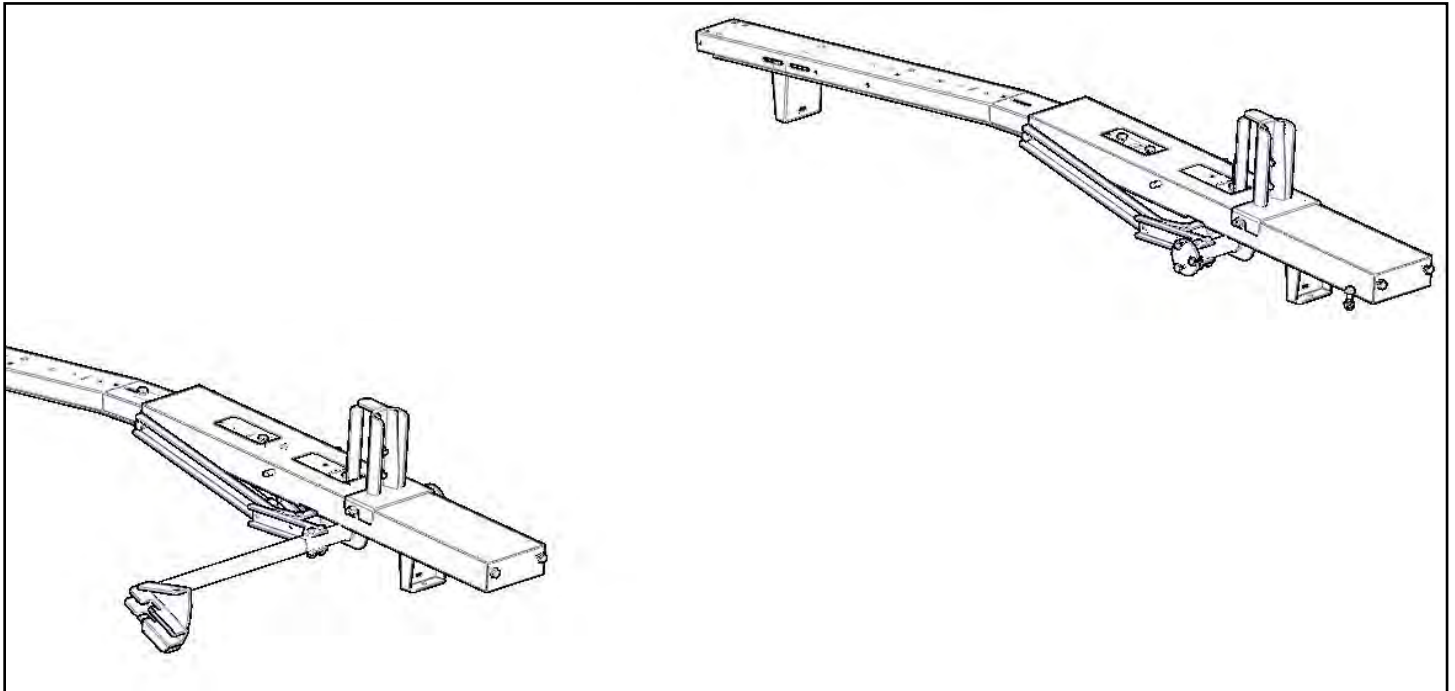

- Bolt Torque Tube(C) to Rear Bow Assy(B) using three .25" x .875" hex head bolts (5) six .25" flat washers(3) and three .25" nyloc nuts(4).

****You may want to put a foam packing block under the front of torque tube (C) to make it level while tightening.****

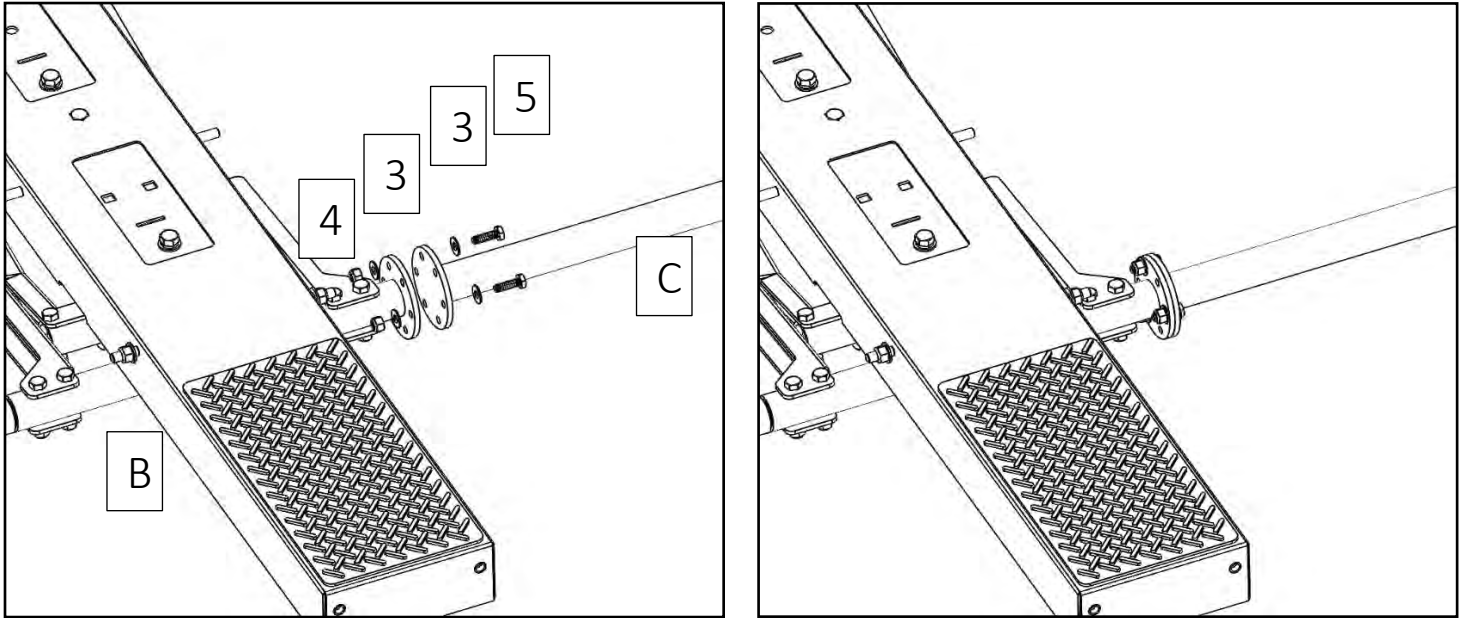

- Repeat process to bolt to the front bow assembly(A).

****If installing on a High Roof Extended Transit, the Torque Tube Extension (K) will be used****
This extension goes inbetween the torque tube (C) and the front bow (A)

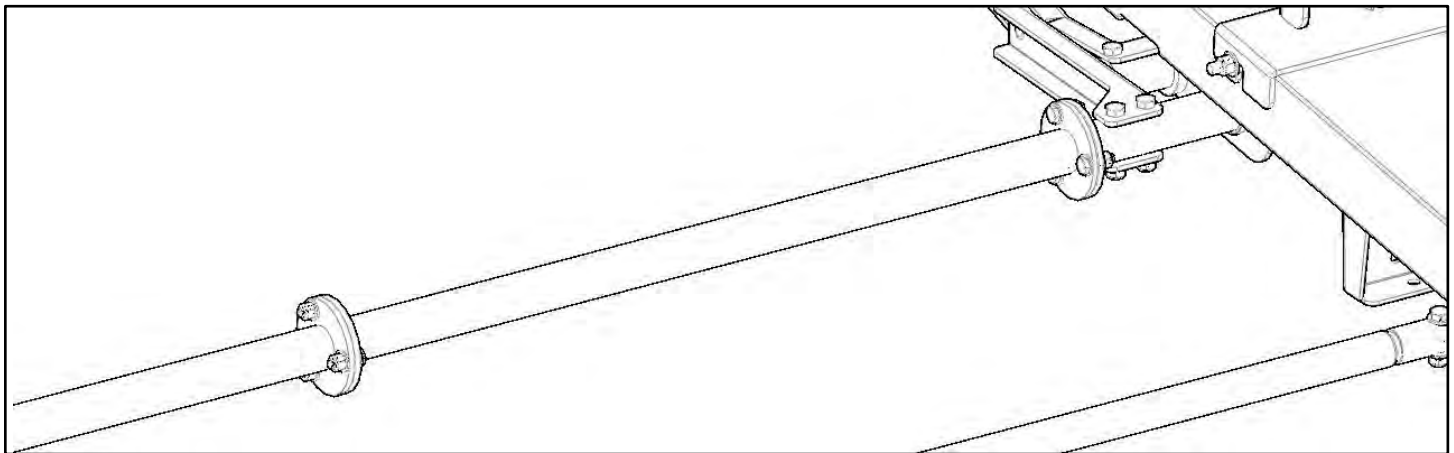

Step 4 – Ladder Pan Support

A.

- Assemble Support Tube(D&E). Put E6000(13) into tube swedge and around the bolt holes to prevent water from getting into tubes.

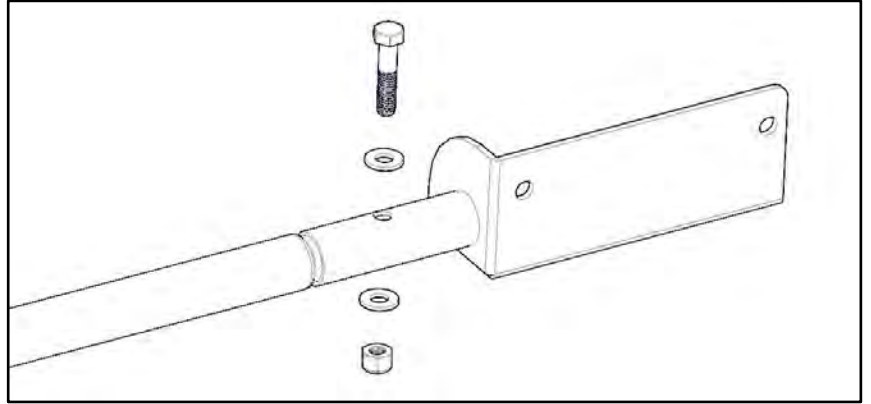

****If installing on a High Roof Extended Transit, the support tube extension (L) will be used****
This extension goes inbetween the support tube (D) and the support tube end (E)

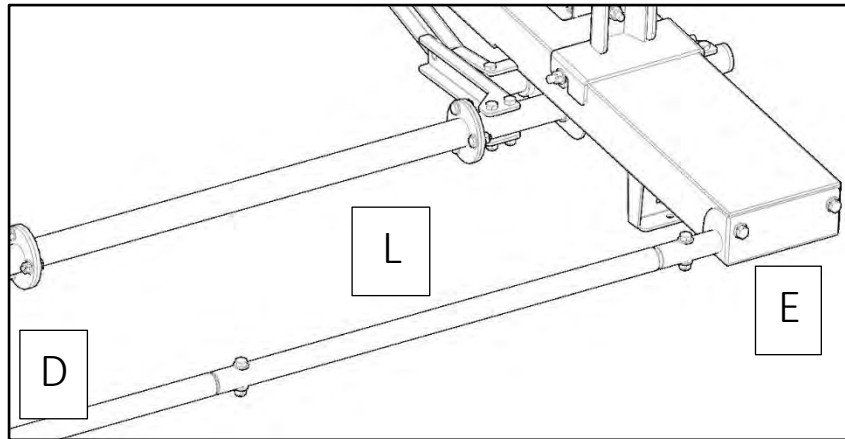

B.

- Attach Support Tube(D&E) to the Ladder pan as shown using .312" x .625 hex head (7) with .312" lock washers(8) and .312" flat washers(6)

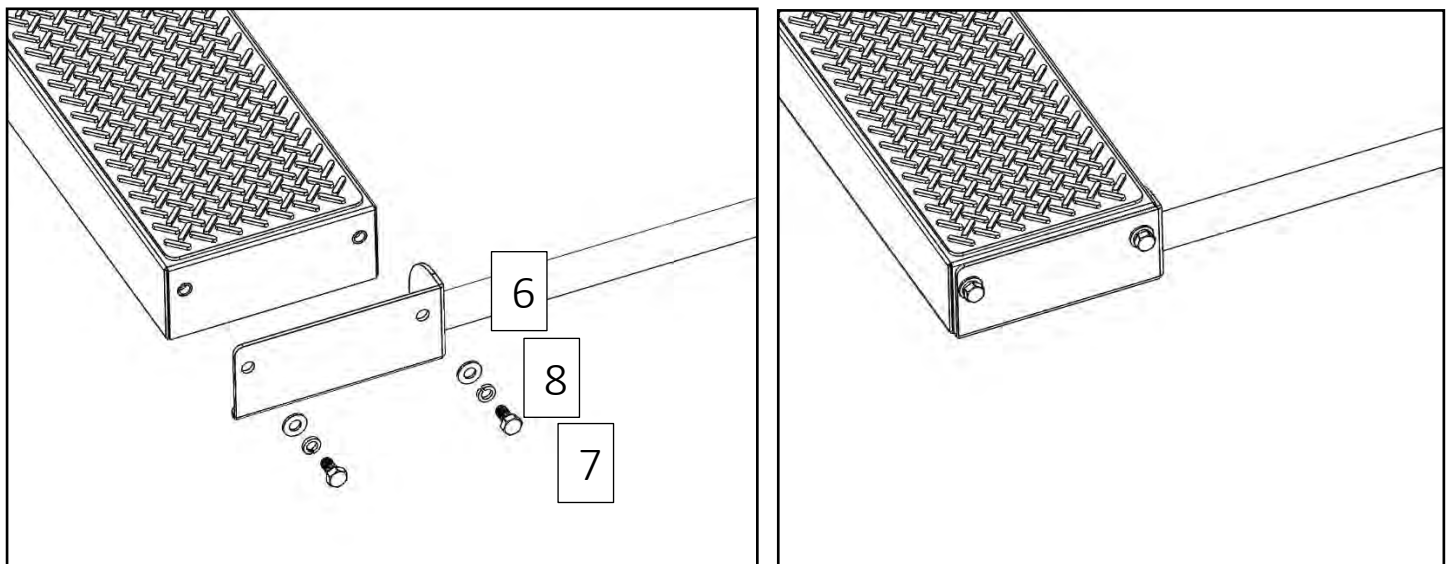

Step 5 – Ladder Stops and Hooks

- On the front bow (A), remove 3/8"x3/4" bolt, 3/8" split lock washer and 3/8" flat washer from shown location and install Ladder Stop(I).

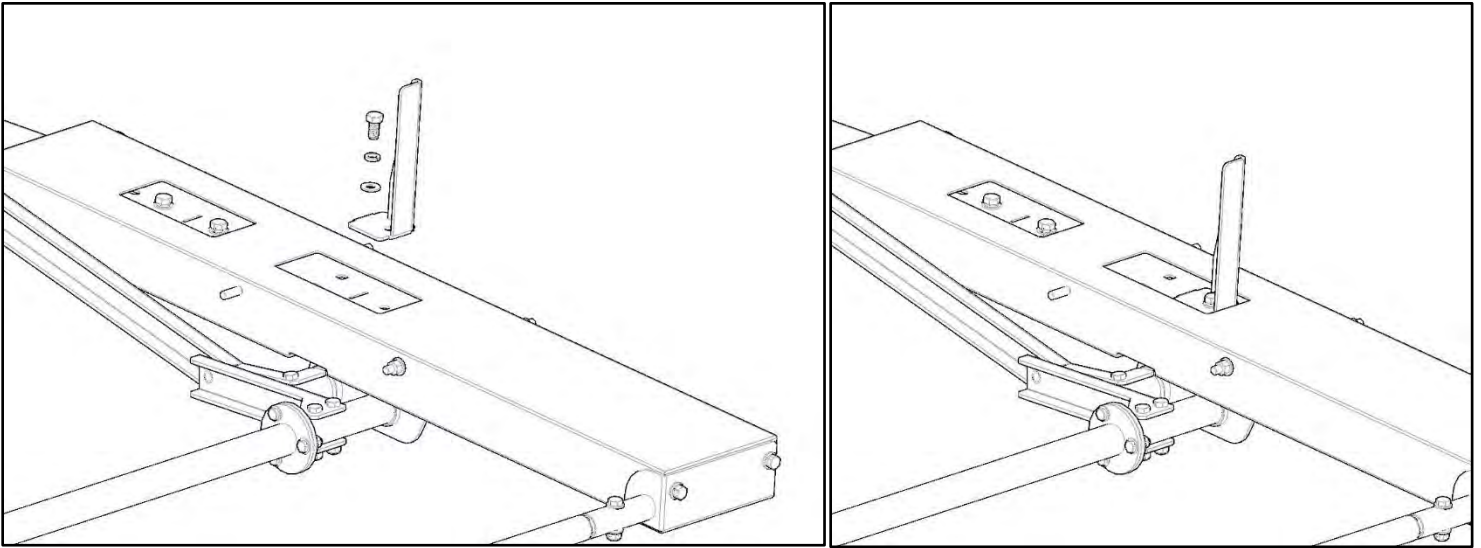

- Bolt Ladder Hook (H) to the lower position where the pem studs are installed. Use a .312 flat washer(6) and a .312 nyloc nut (9).

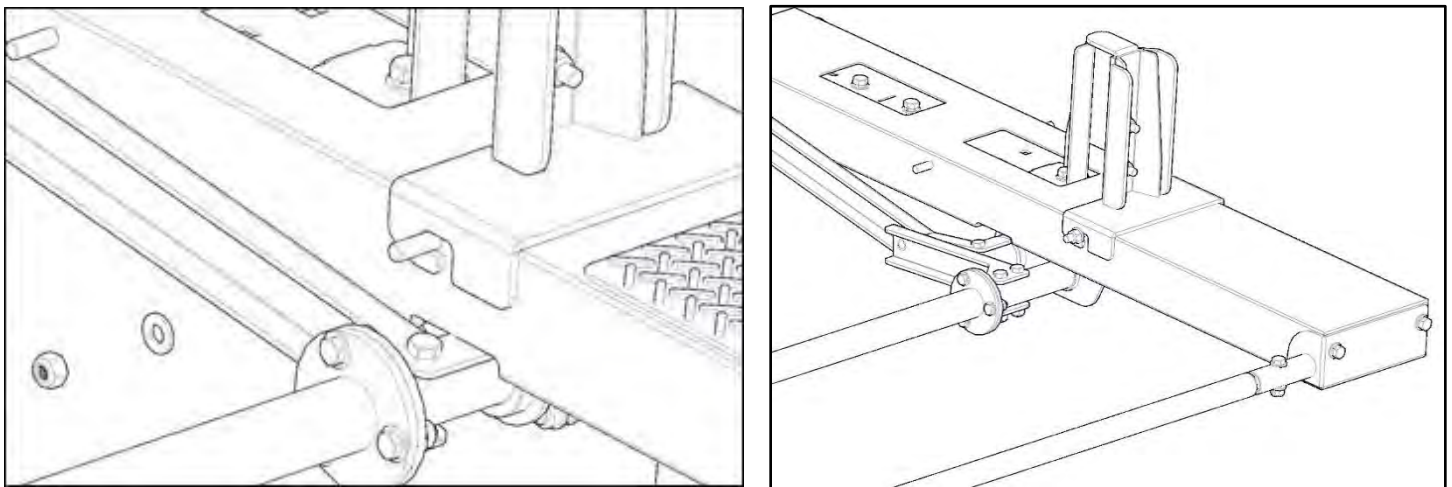

- Repeat on both sides of ladder hook (H).
- If using an "Extension Ladder" put the Ladder Stop(I) at the same location on the Front & Rear Bow Assy.(A&B).

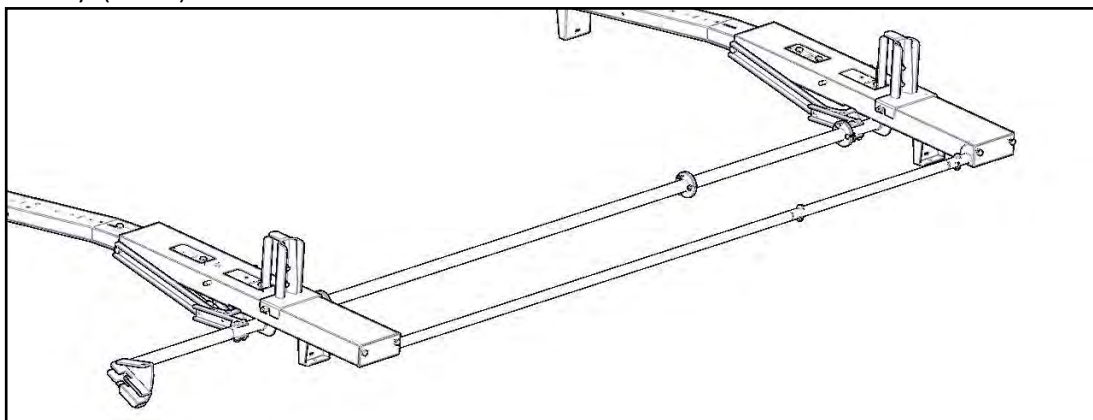

Step Ladder Set-Up

- If installing for a “Step ladder”, The ladder hook (H) and the ladder stop (I) change positions on the rear bow.
- Both of these parts move higher up on the bow and are installed using the other pem studs.

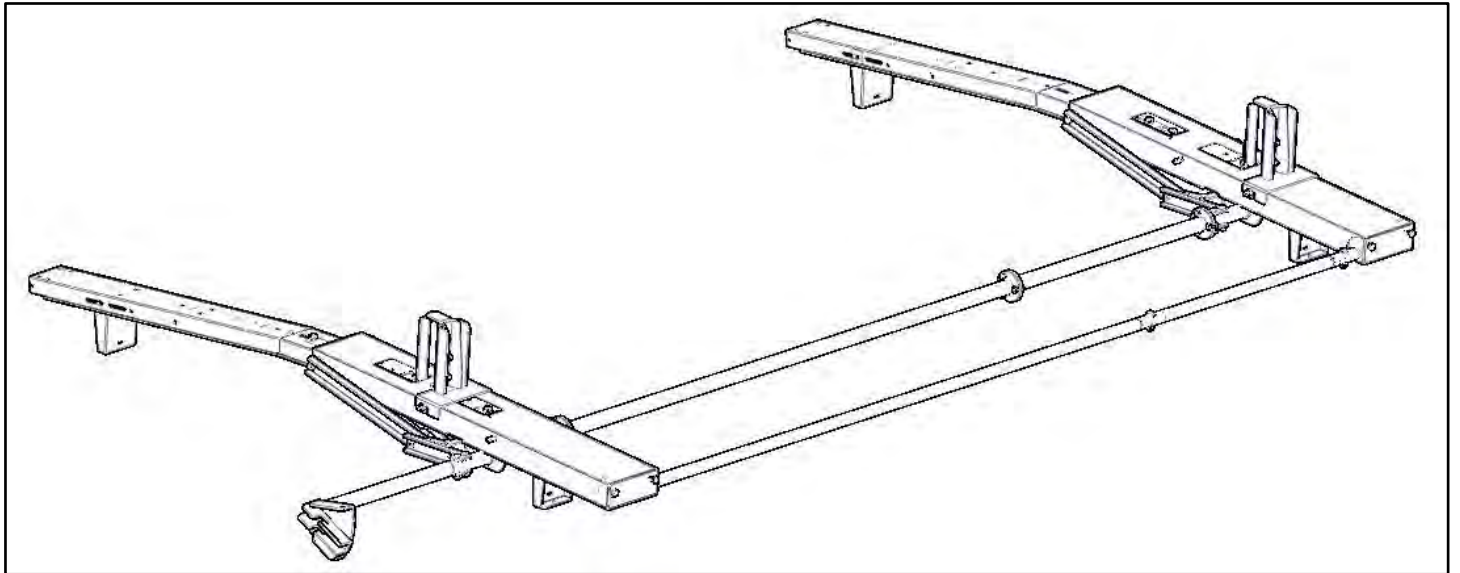
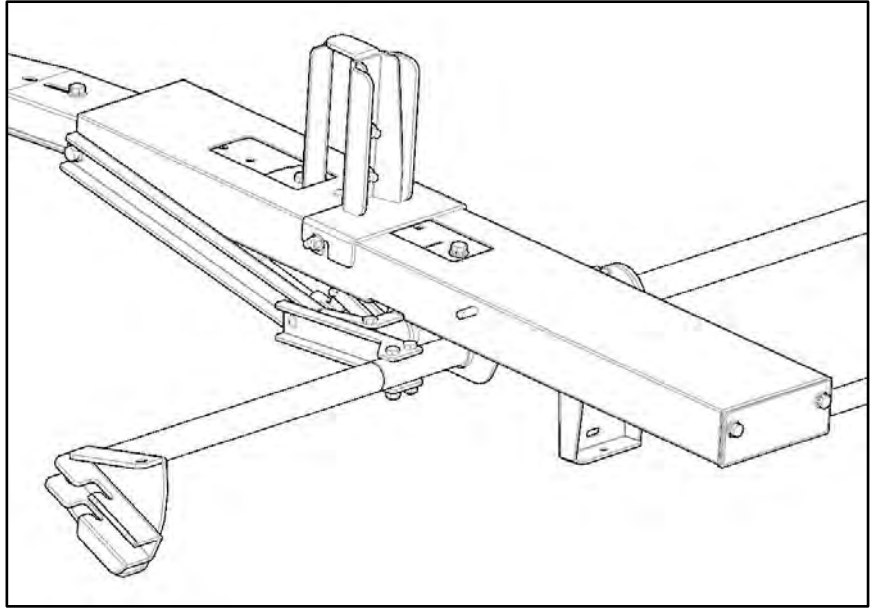

Step 6 – Installing Rack

- If you built the rack on the bench you can now set the rack on the mounts as described in Step 2.
- Be sure rack is centered on the van then TIGHTEN all the hardware.

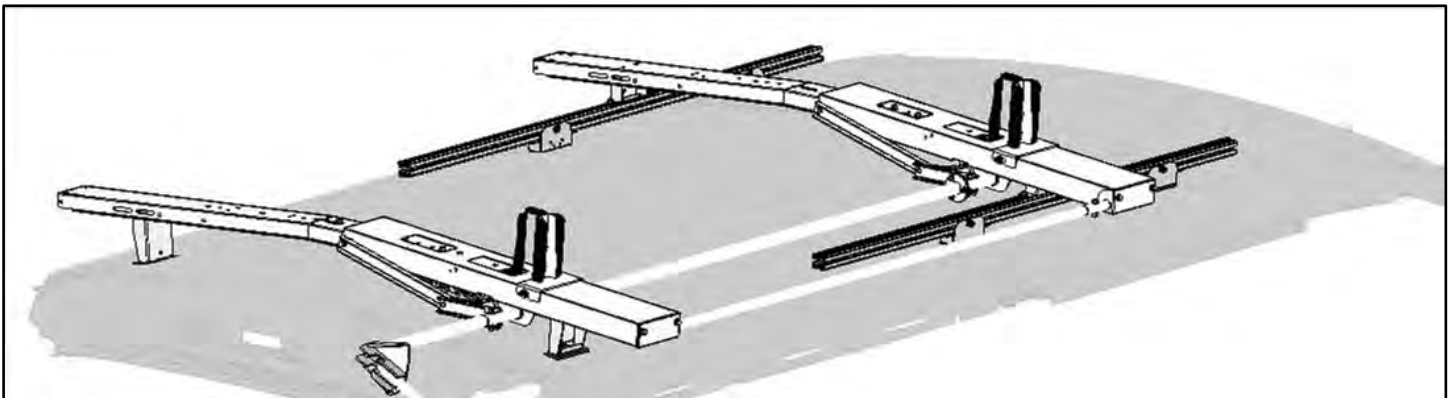

Step 7 – Install Handle Bar holder

- Install handle bar holder clip from hardware kit to your preference. Most install at the rear of the van, on the backside of a shelving unit.
 - Install clips using #10 hardware provided.
-

GO BACK AND ENSURE ALL HARDWARE IS TIGHT

Your installation is now complete.
