

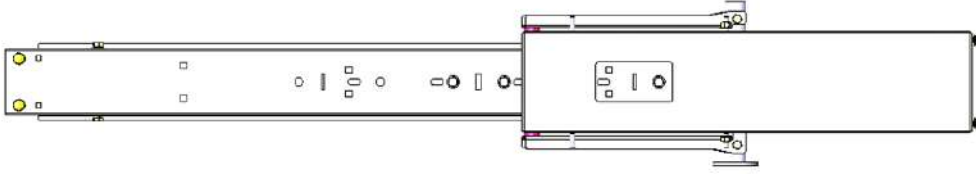

**WE PUT EVERYTHING WITHIN REACH.**

## Installation Instructions

### 40933 Parts List



**Front Bow Assy. (1)**

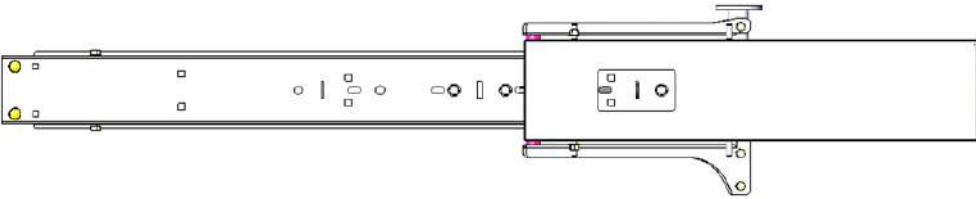

**Rear Bow Assy. (1)**



**Rail Mount Foot (4)**



**Latch (1)**



**Ladder Hook (2)**



**Ladder Stop (2)**



**Torque Tube (1)**



**Ladder Pan Stiffener (1)**



**Mount Rail (2)**



**Handle Assy. (1)**

# 40933 Hardware List

## Tools Needed

8' Tape Measure	1/2" End Wrench
1/2" Socket	9/16" End Wrench
9/16" Socket	Hammer
7/16 Socket	

## Hardware Pack

(a)  
Qty 6 -  
5/16"-18 x 3/4" Carriage Bolt



(b)  
Qty 26 -  
5/16" Flat Washer



(c)  
Qty 8 -  
5/16" Lock Washer



(d)  
Qty 14 -  
5/16"-18 Nyloc Nut



(e)  
Qty 4 -  
5/16"-18 x 5/8" Hex Bolt

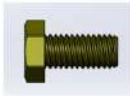

(f)  
Qty 6 -  
Round Rubber pad



(g)  
Qty 4 -  
Fender Washer - 24mm OD x 2mm TK



(h)  
Qty 4 -  
M8 Nyloc nut



(i)  
Qty 4 -  
5/16"-18 x 1" Hex Bolt

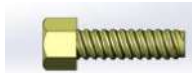

(j)  
Qty 8 -  
3/8"-16 x 3/4" Hex Bolt



## Hardware Pack Cont'

(k)  
Qty 8 -  
3/8" Flat Washer



(l)  
Qty 8 -  
3/8" Lock Washer



(m)  
Qty 6 -  
1/4"-20 x 7/8" Fully Threaded Hex Bolt



(n)  
Qty 12 -  
1/4" Washer



(o)  
Qty 6 -  
1/4"-20 Nyloc Nut



(p)  
Qty 4 -  
M8 x 25mm Hex Bolt



(q)  
Qty 2 -  
M8 x 20mm Counter Sink Bolt



(r)  
Qty 1 -  
Joint Sealant



(s)  
Qty 6 -  
M6 x 20mm Hex Bolt

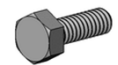

(t)  
Qty 6 -  
M6 Flat Washer



(u)  
Qty 6 -  
M6 Lock Washer



### Step 1 For Ram Promaster City

Install "Mount Rail" as shown using M6x20mm bolts (s) with lock washers(u) and flat washers(t). Be sure to put rubber washer(f) between the "Mounting Rail" and the roof to insure sealing. (Passenger side shown)

#### FRONT

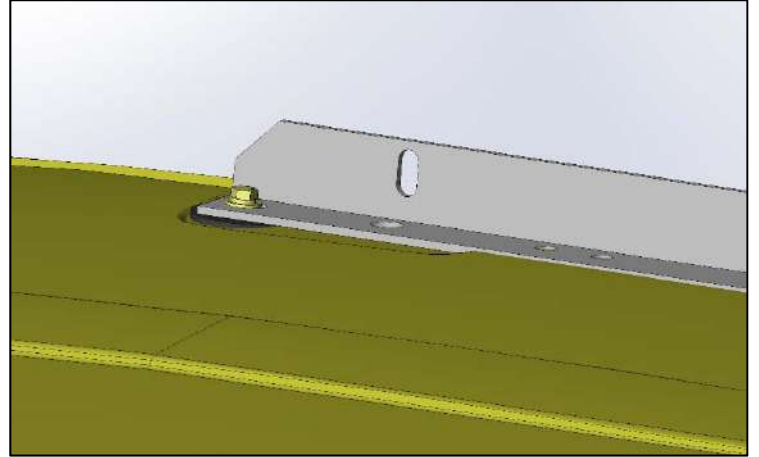
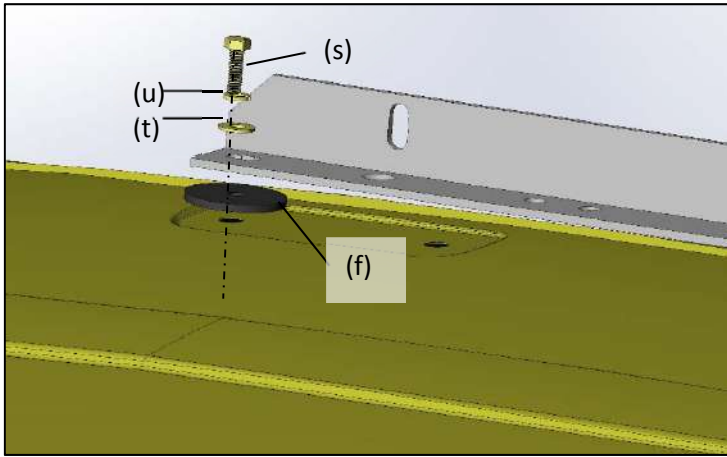

#### BACK

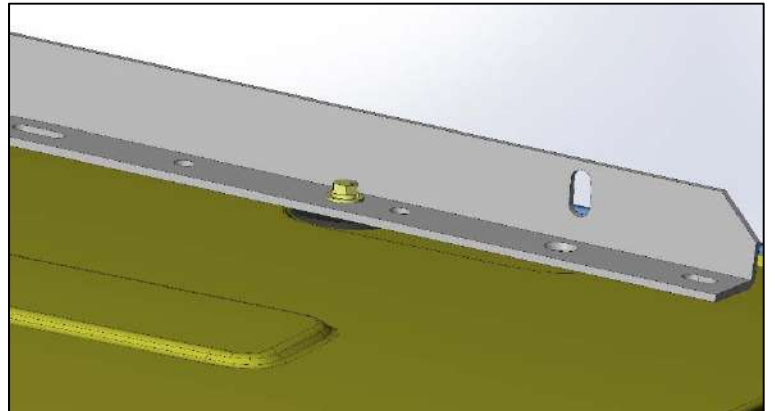
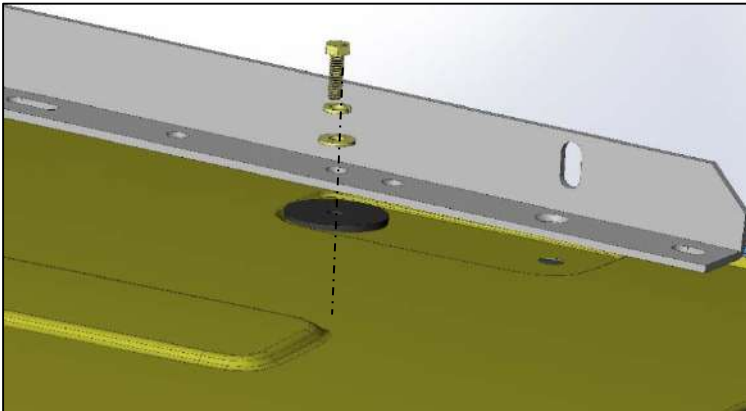

#### Middle

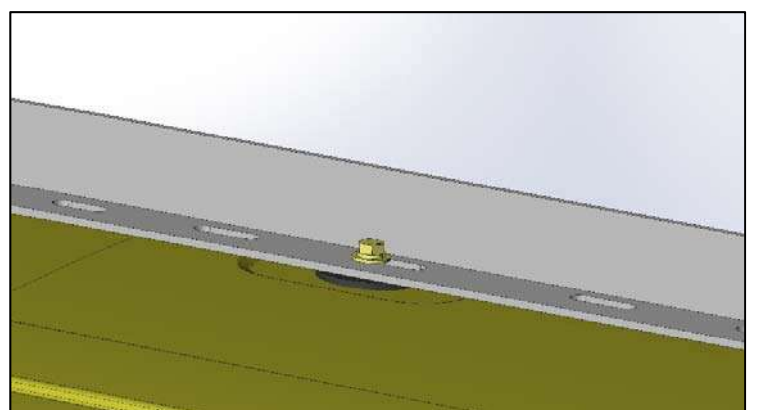
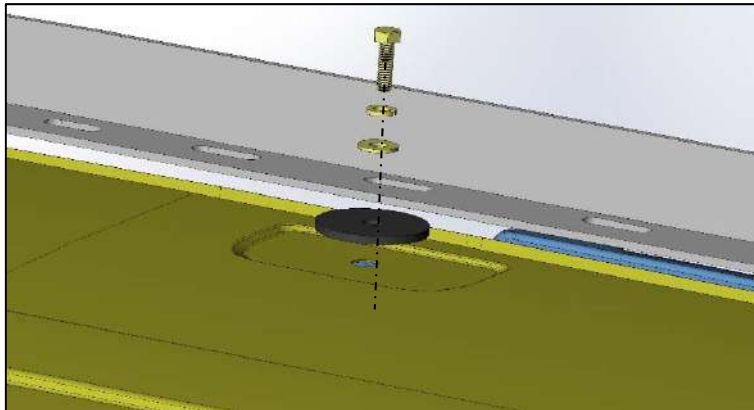

### Step 1 For NV200/Chevy City Express/2014 Transit Connect

Mount rail to roof using M8x25 Bolts (p) with flat washer (b) and lock washers(c) (on 2014 and newer Transit Connect use nyloc nut with fender washer and rubber washer on the underside-Do not use lock washer). Mount rail so that the end of the rail is approximately 1" (usually the 2<sup>nd</sup> or 3<sup>rd</sup> hole-Use countersunk hole for 2013 and older Transit Connect) from where the rear door opening is.

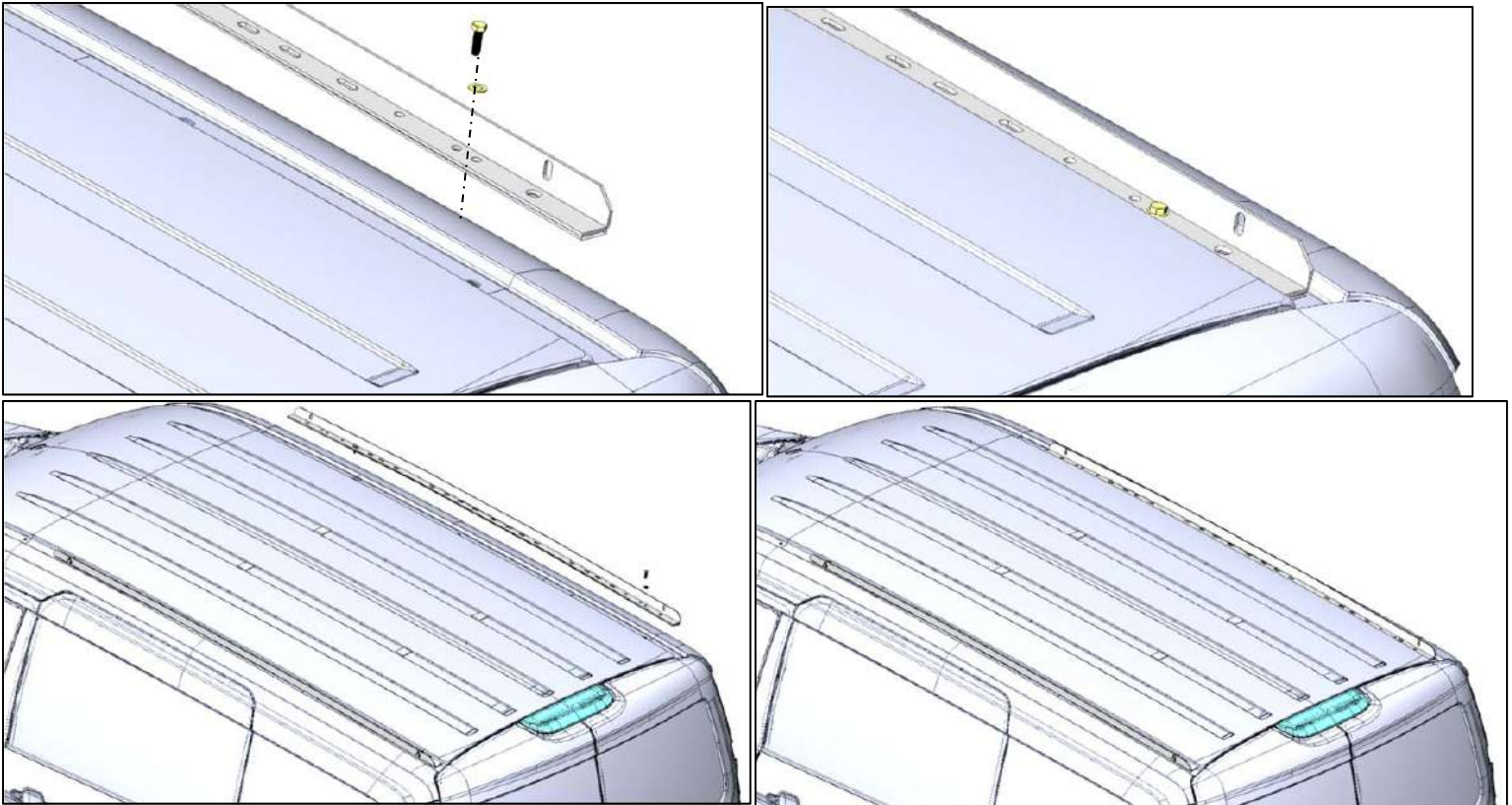

### Step 2

Measure width the rail and bolt feet to bows at that approximate location as shown, DO NOT TIGHTEN at this point.

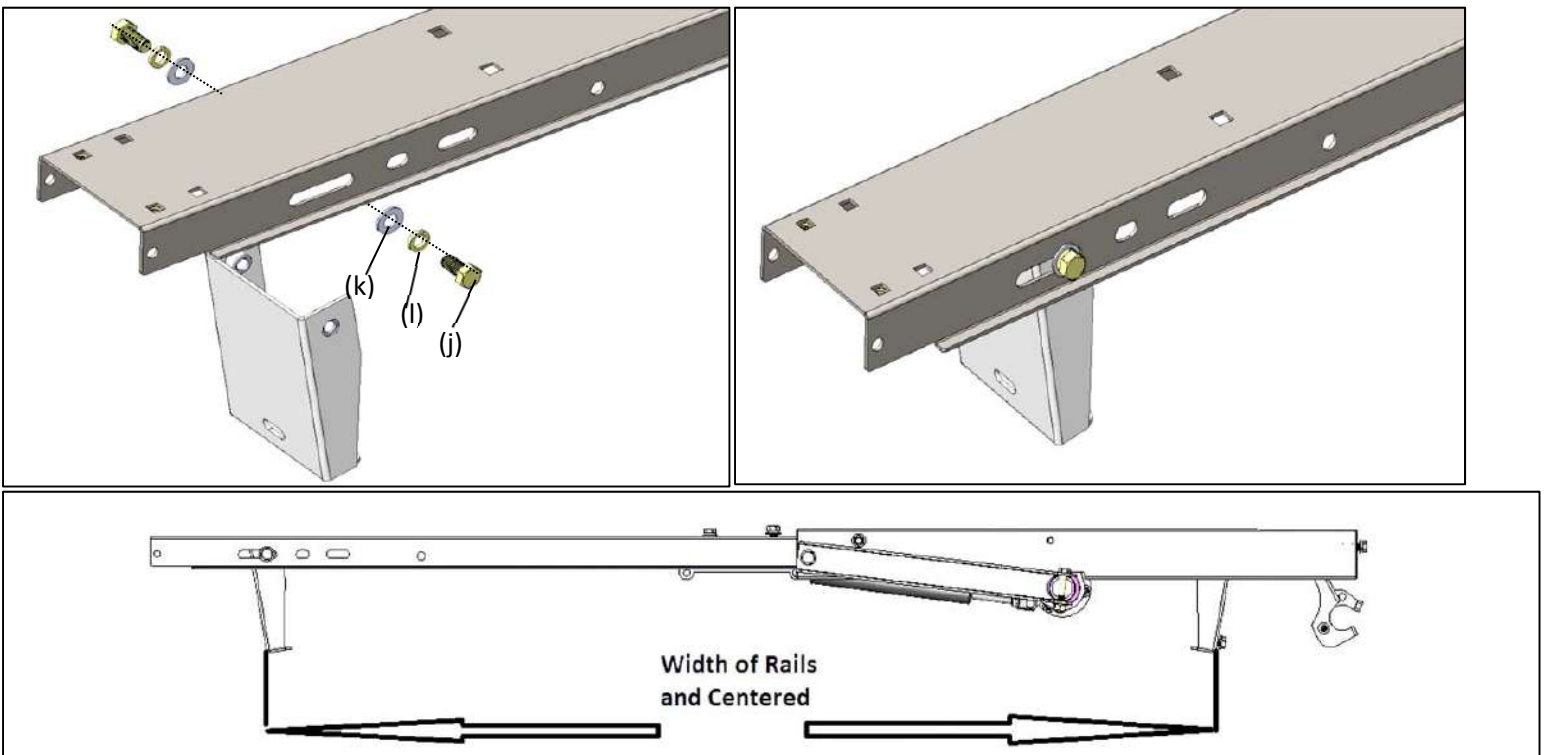

### **Step 3**

Bolt "Latch" as shown using 5/16"x3/4" carriage bolts (a) with flat washers (b) and nyloc nuts (d).

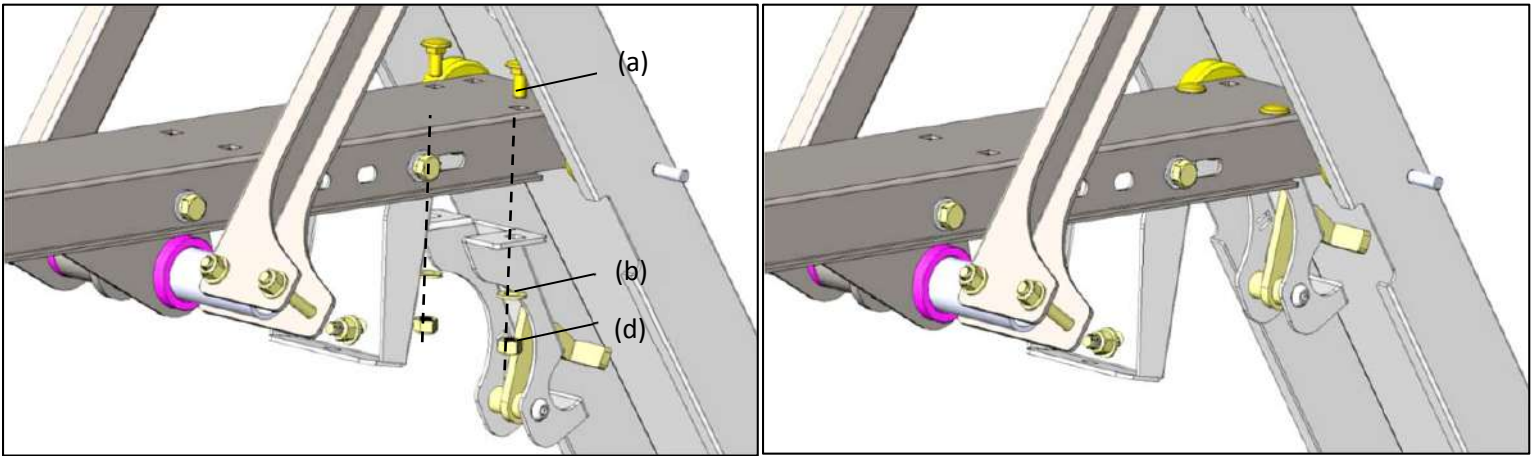

### **Step 4**

Next bolt the Angle bracket on the driver side of the bows using 5/16"x3/4" carriage bolts with nyloc nuts and flat washer as shown.

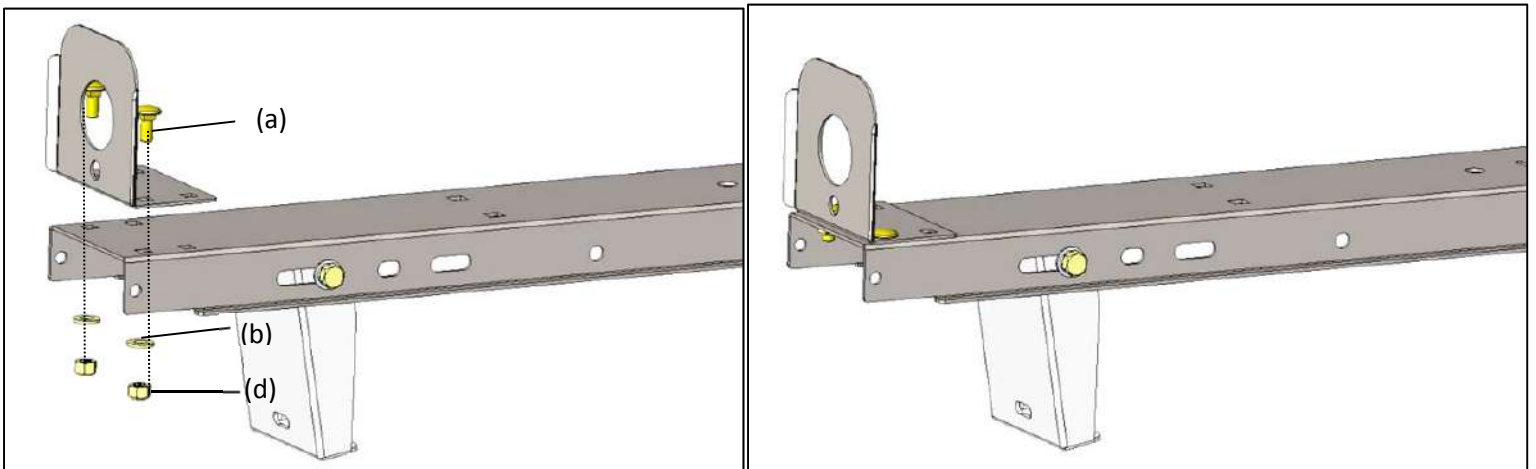



**Step 5**

Place "Rear Bow Assy." as shown and bolt to rails using 5/16"x1" bolts (j) with nyloc nuts(d) and flat washers(b), DO NOT TIGHTEN at this time.

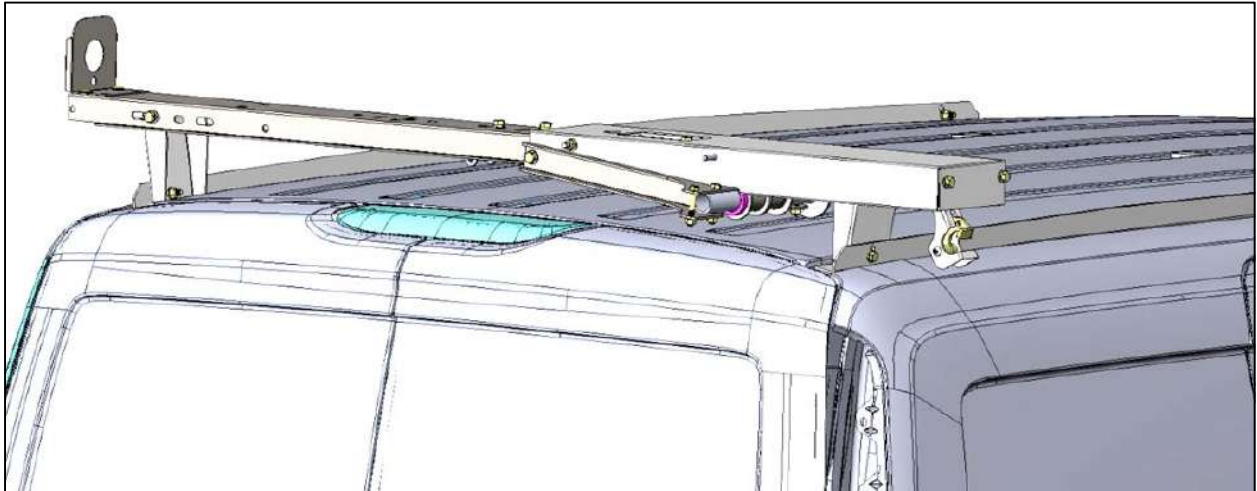
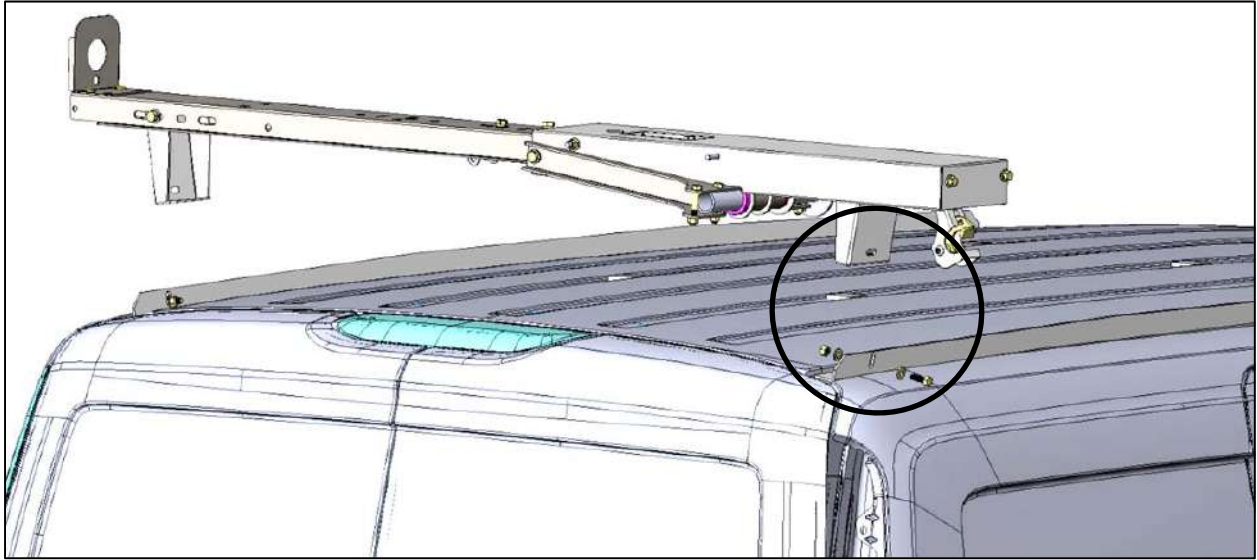

**Step 6**

Place "Front Bow Assy." as shown and bolt to rails using 5/16"x1" bolts(i) with nyloc nuts(d) and flat washers(b), DO NOT TIGHTEN at this time.

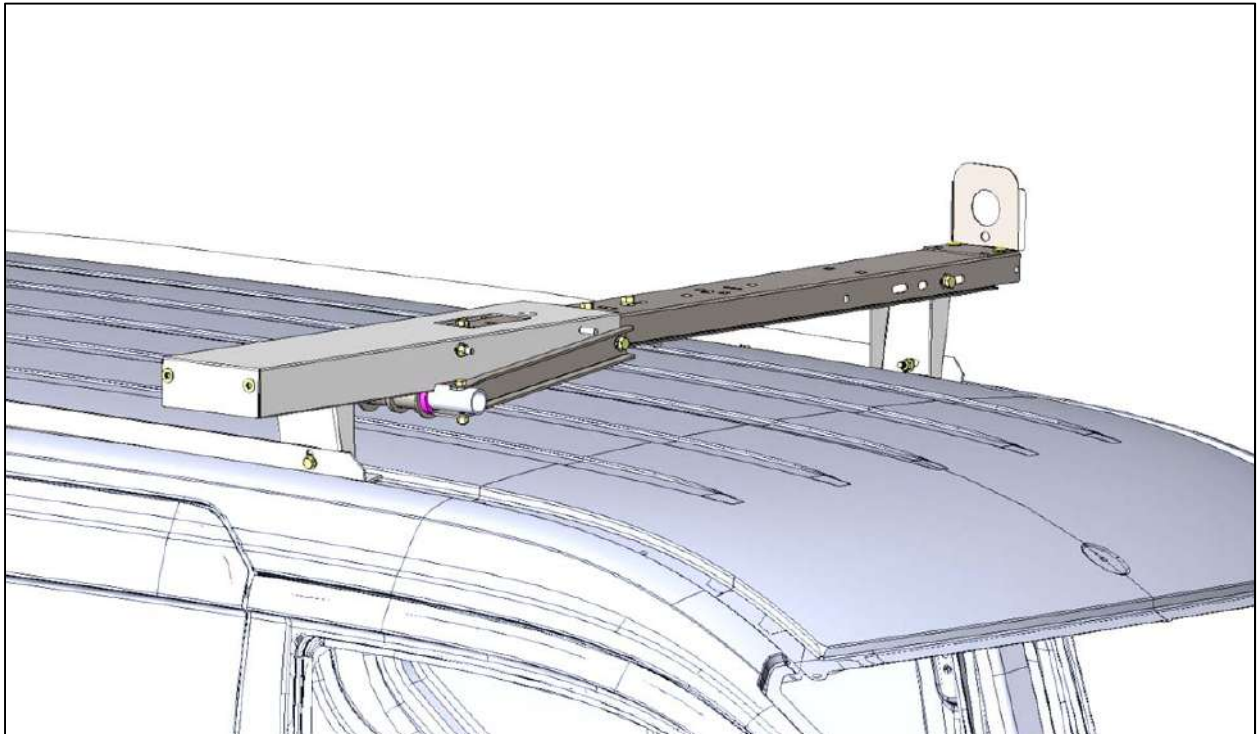
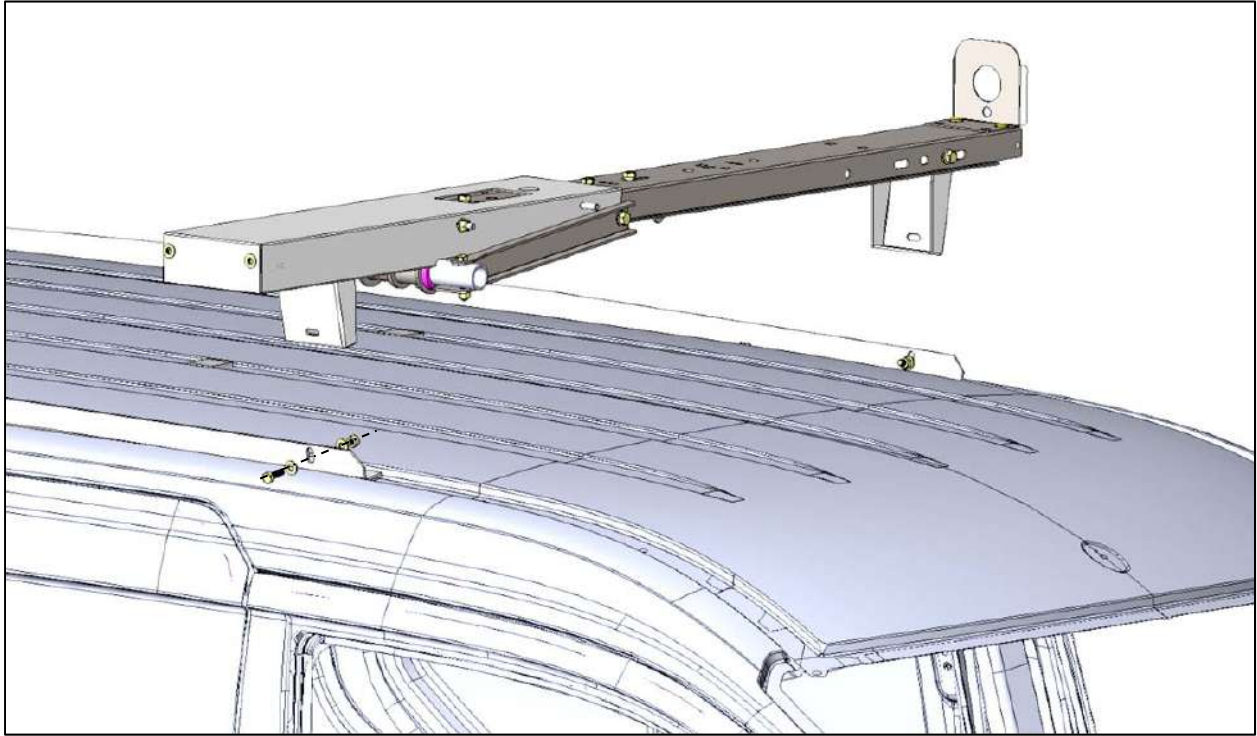

**Step 7**

Bolt the "Torque Tube" using 1/4" x 7/8" bolts(m) with flat washer(n)s and nylock nuts(o). This sets the distance between the front and rear assembly (71.5" center to center), be sure both sides measure the same to ensure proper operation.

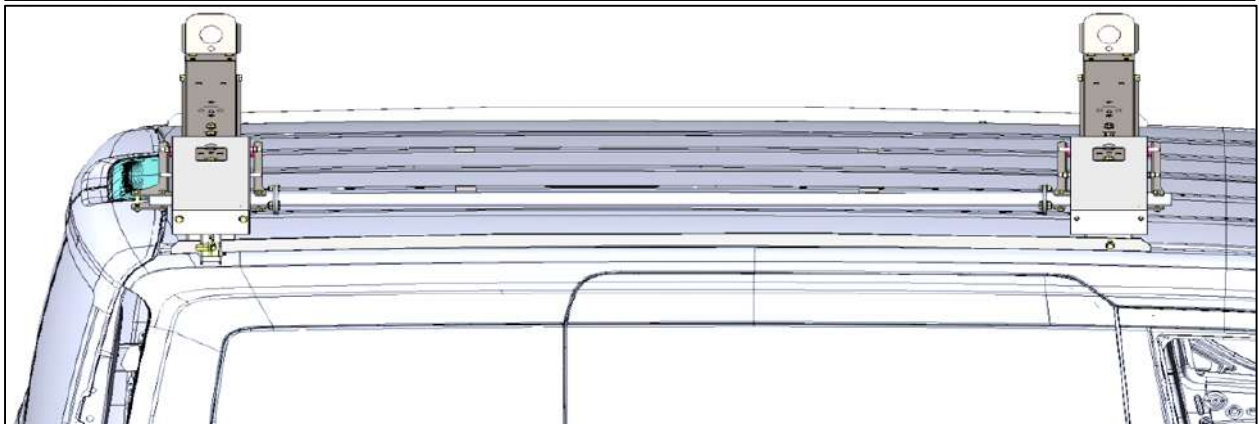
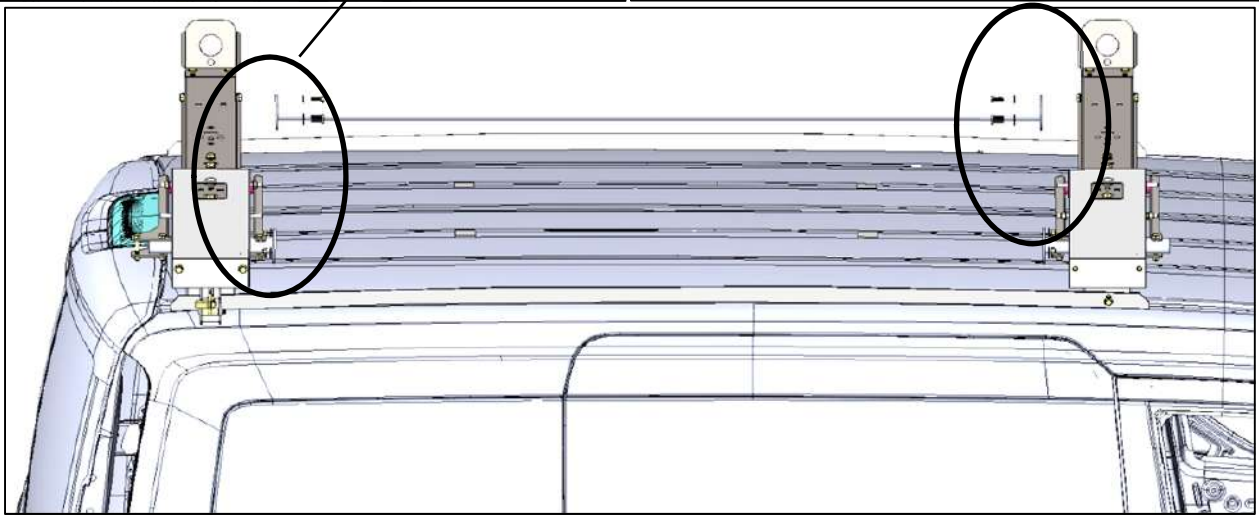
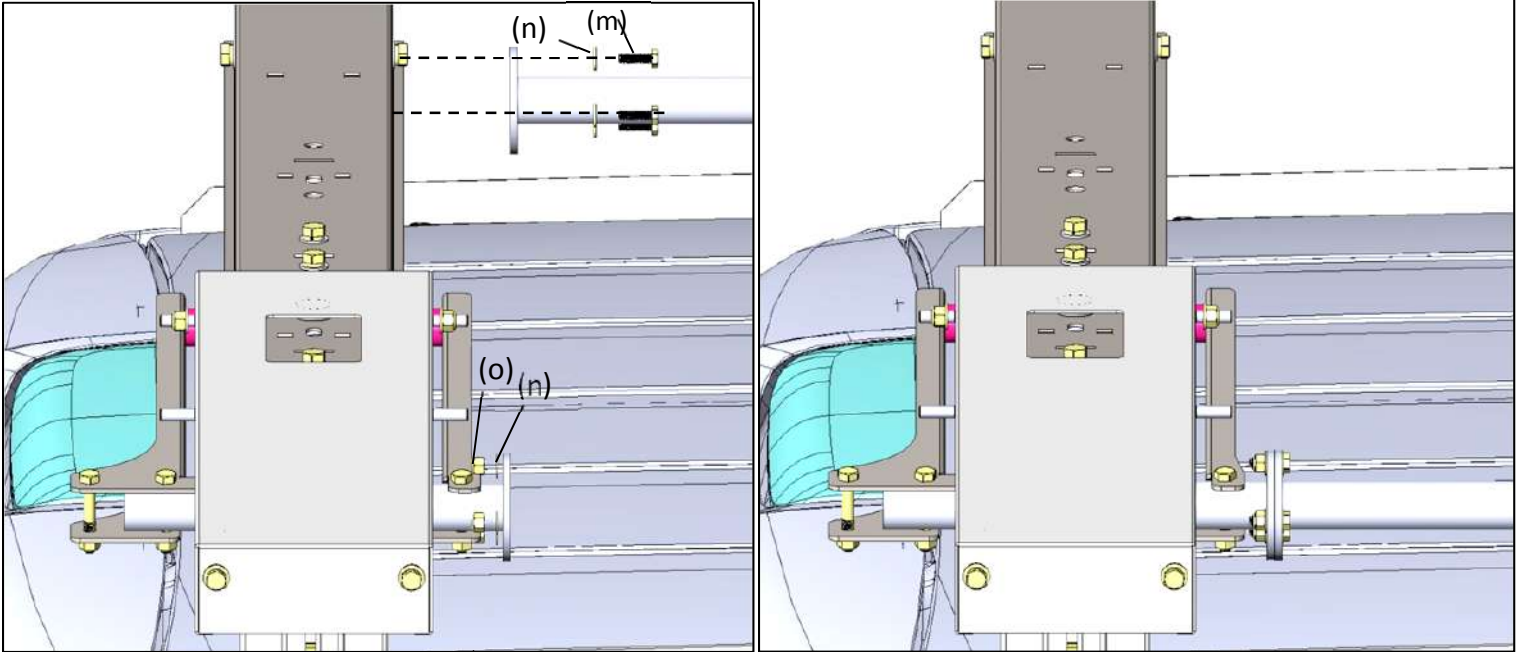



## **Step 8**

Next bolt the "Handle Assy." Using 5/16"x2" bolts with a nyloc nut and flat washers as shown. BE SURE HANDLE WILL CLEAR THE REAR DOORS during operation. If it doesn't clear then the rails need to be mounted back farther on the van.

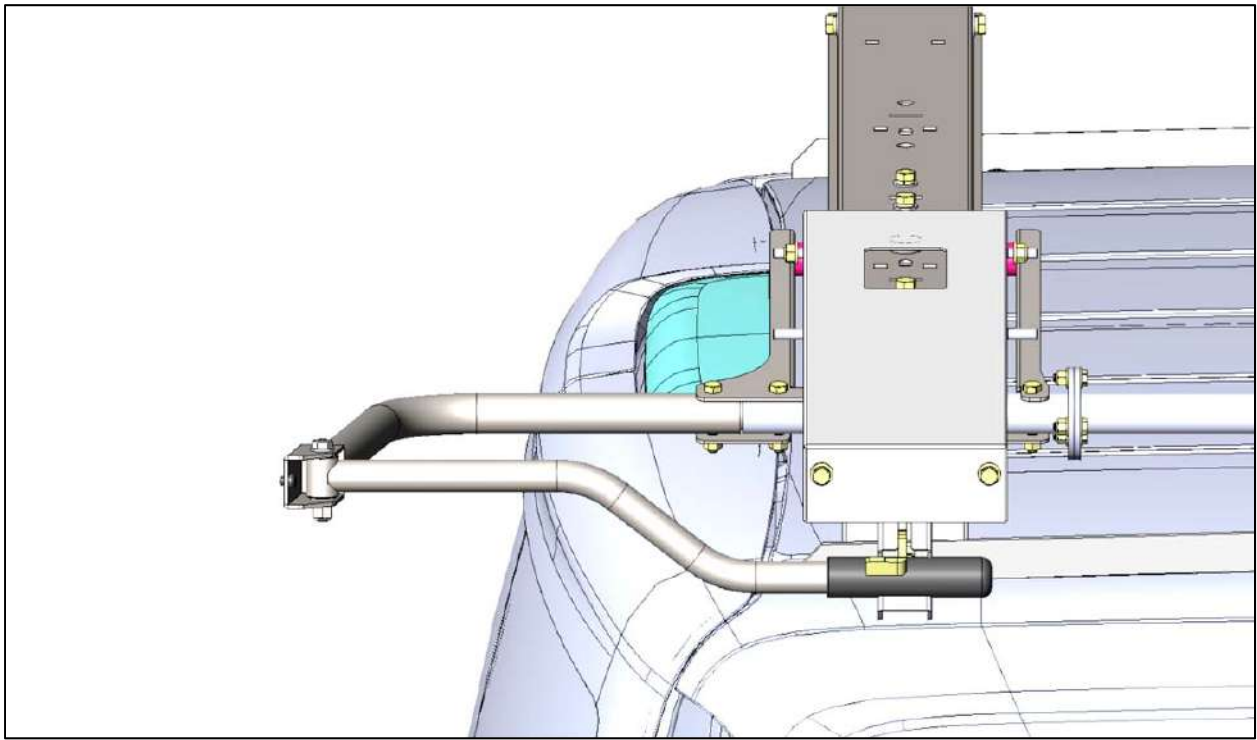
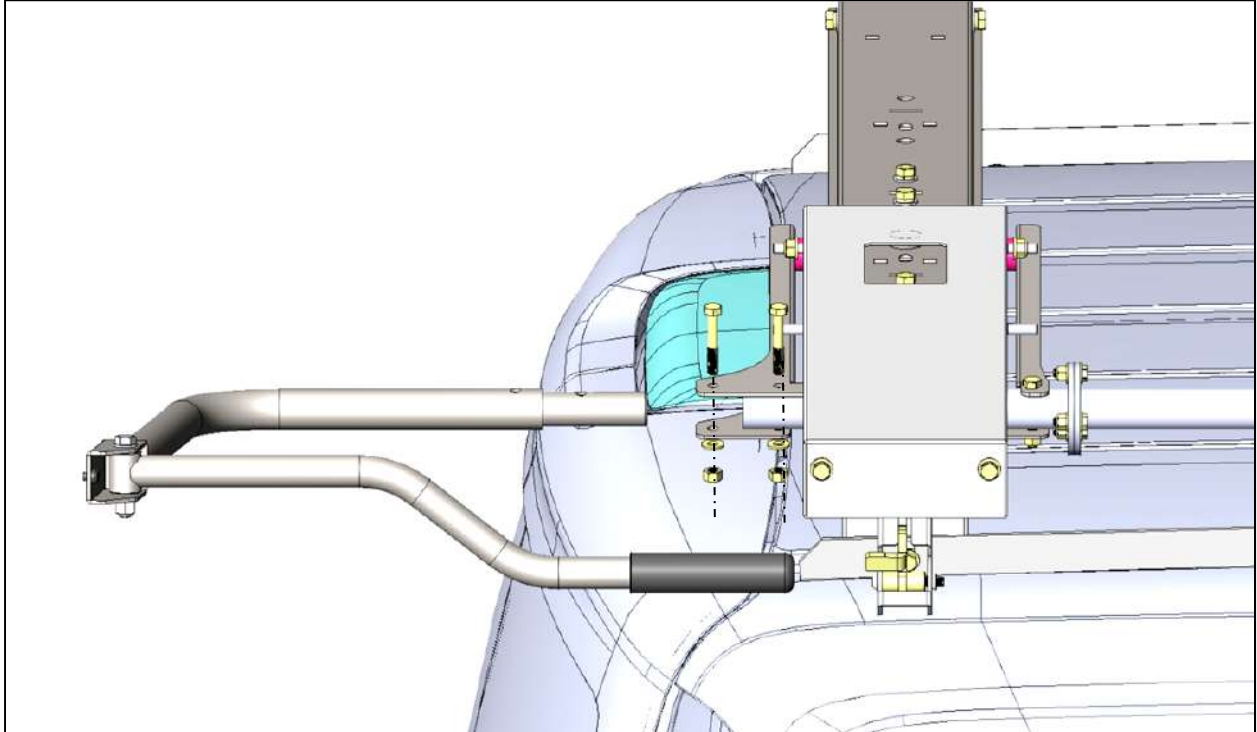

## Step 9

Next attach the “Ladder Pan Stiffener” using 5/16”x5/8” bolts(e) with lock washer(c) and flat washers(b) as shown. With that completed you can now go back and tighten the feet to the rails and then the feet to the front and rear bow assemblies, double check the center to center dimension before tightening (71.5”).

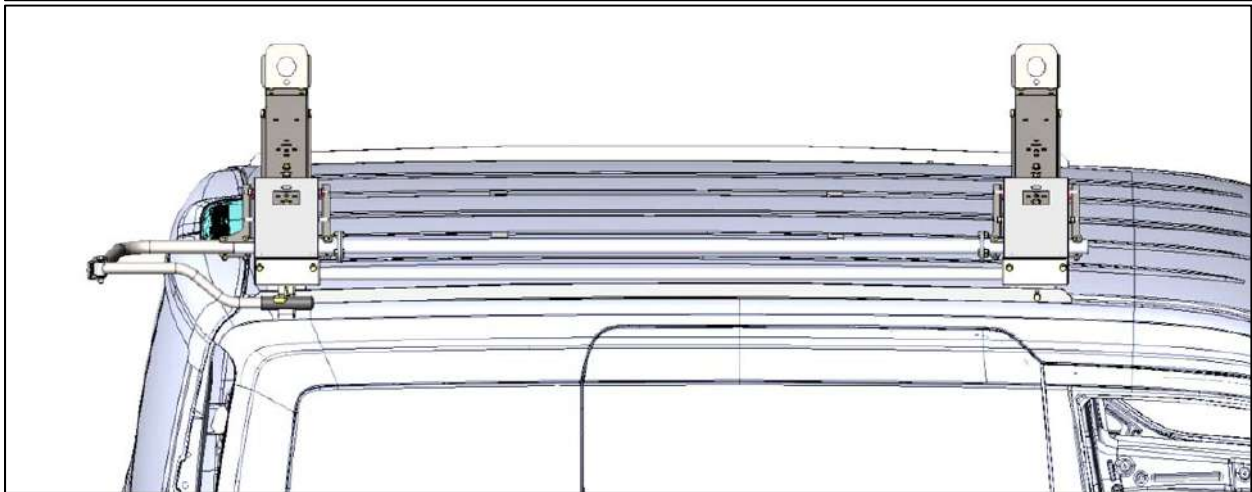
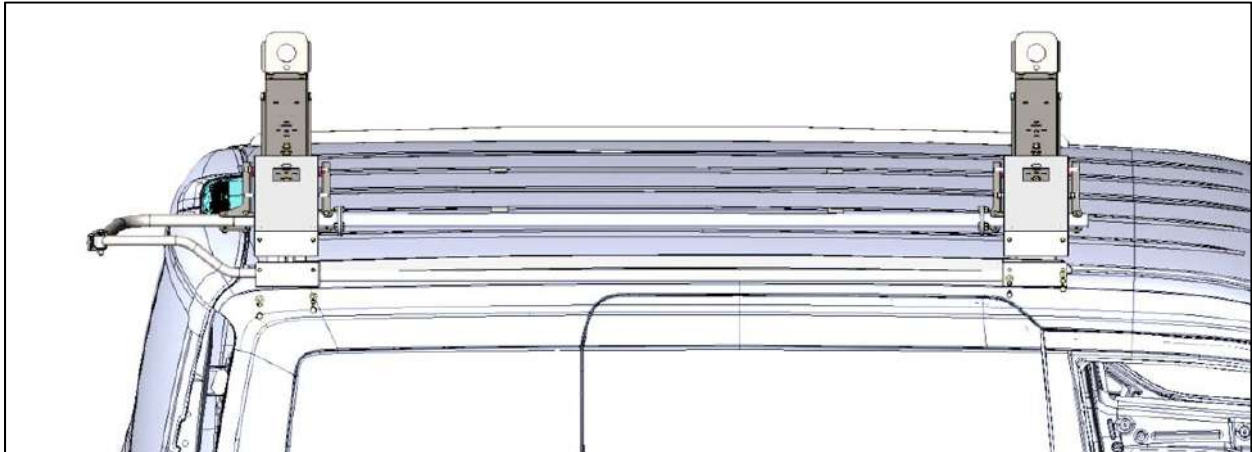
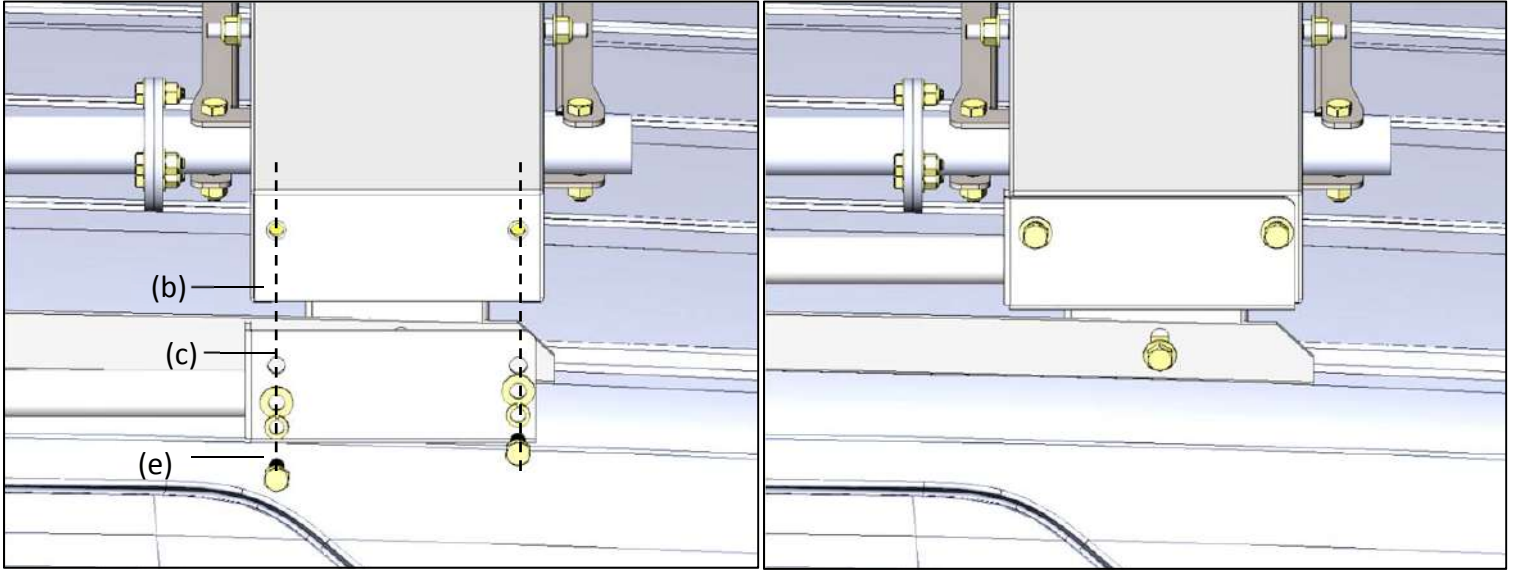

**Step 10**

Next attach the "Ladder Hooks" and "Ladder Stops". The first 4 pictures show the front hooks, the next 4 show the rear hook set in the "step ladder" location. If you are using an extension ladder use the same location as the front bow.

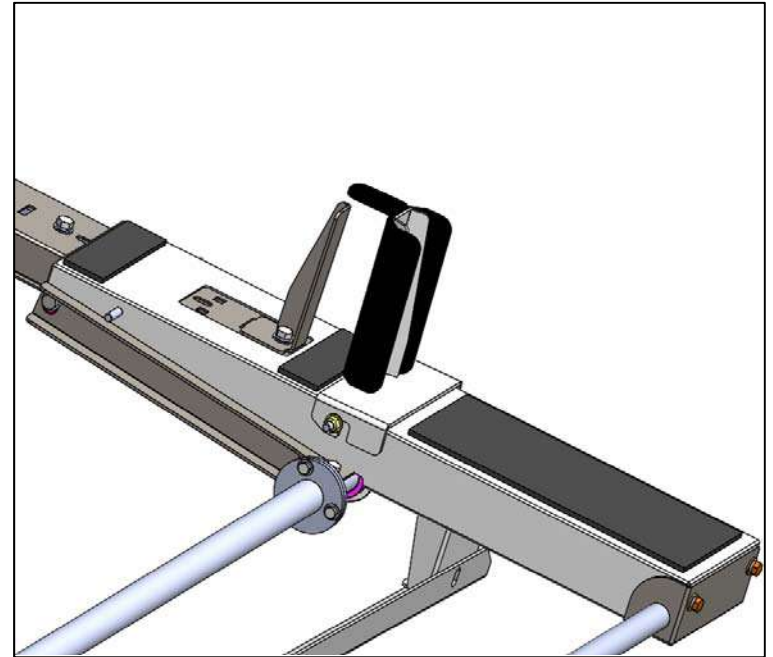
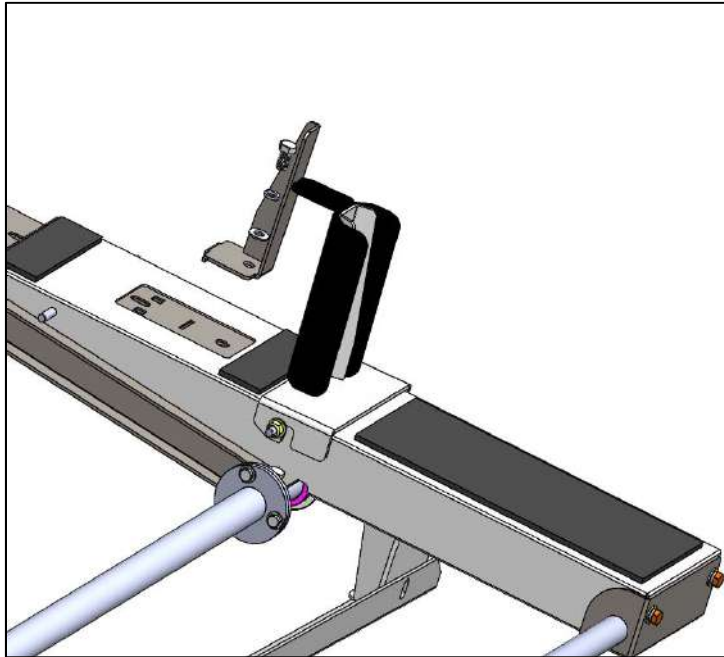
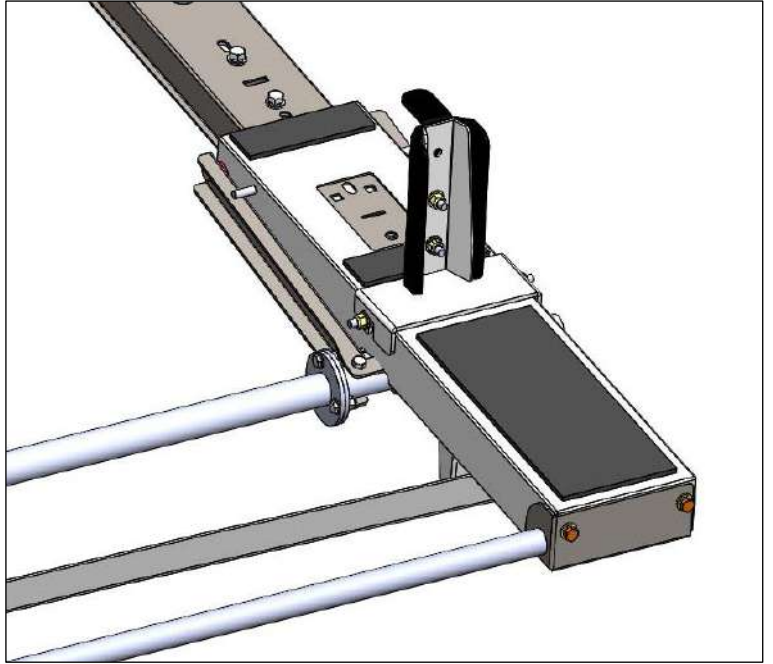
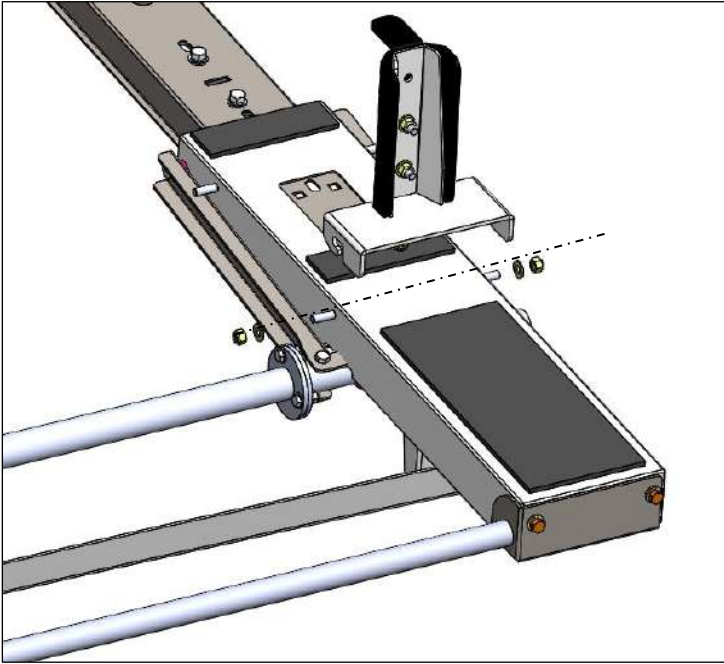

Rear bow location for step ladder.

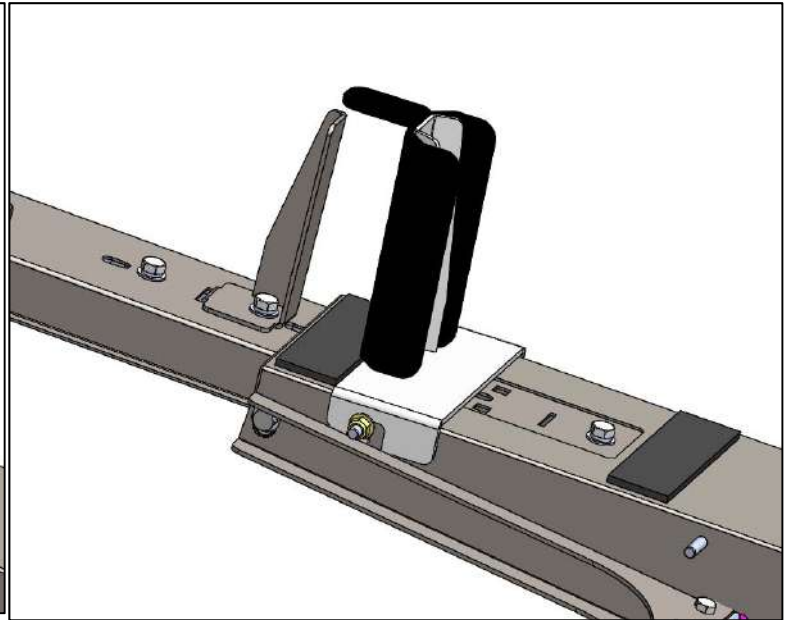
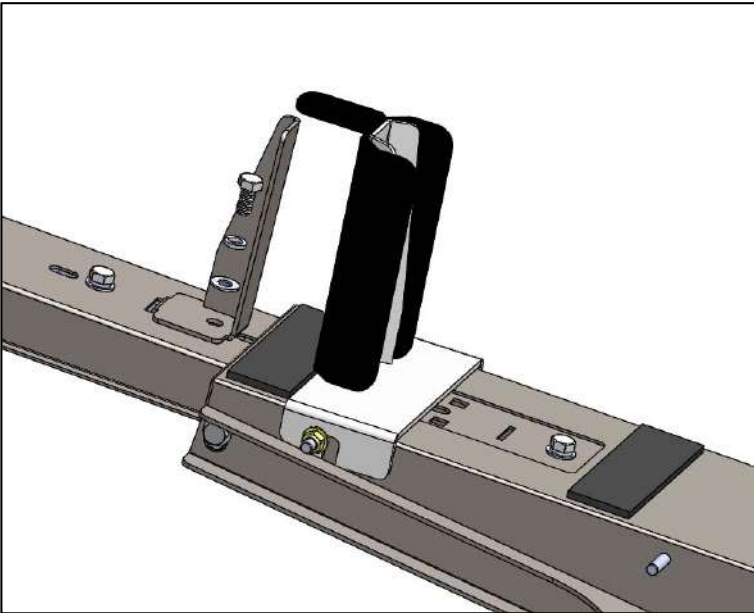
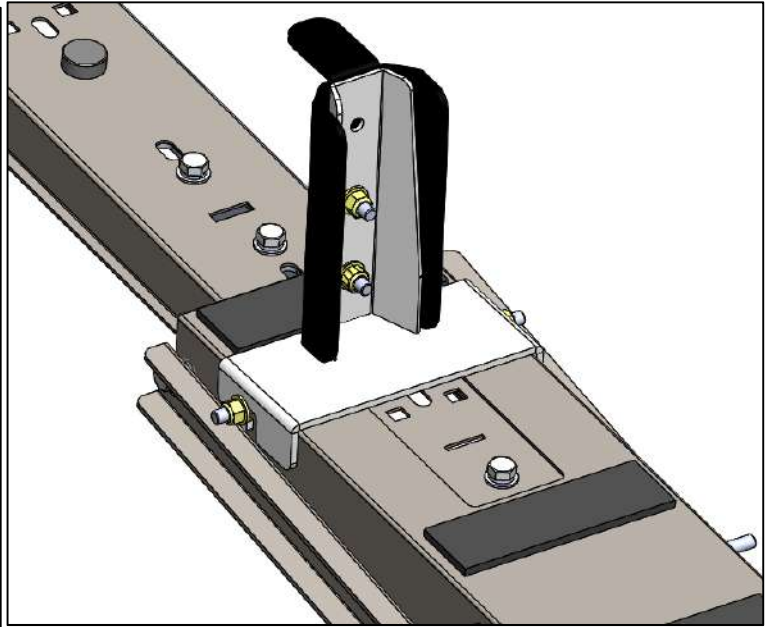
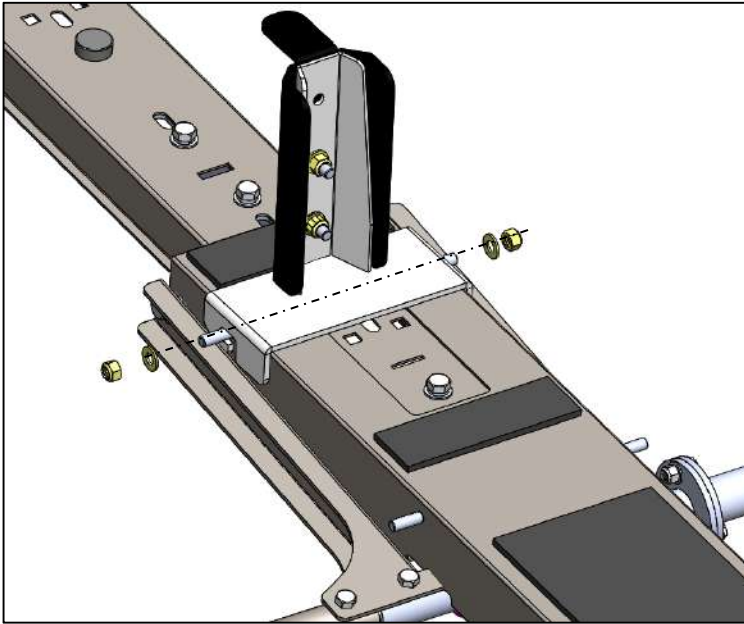



Installation complete for "step ladder".

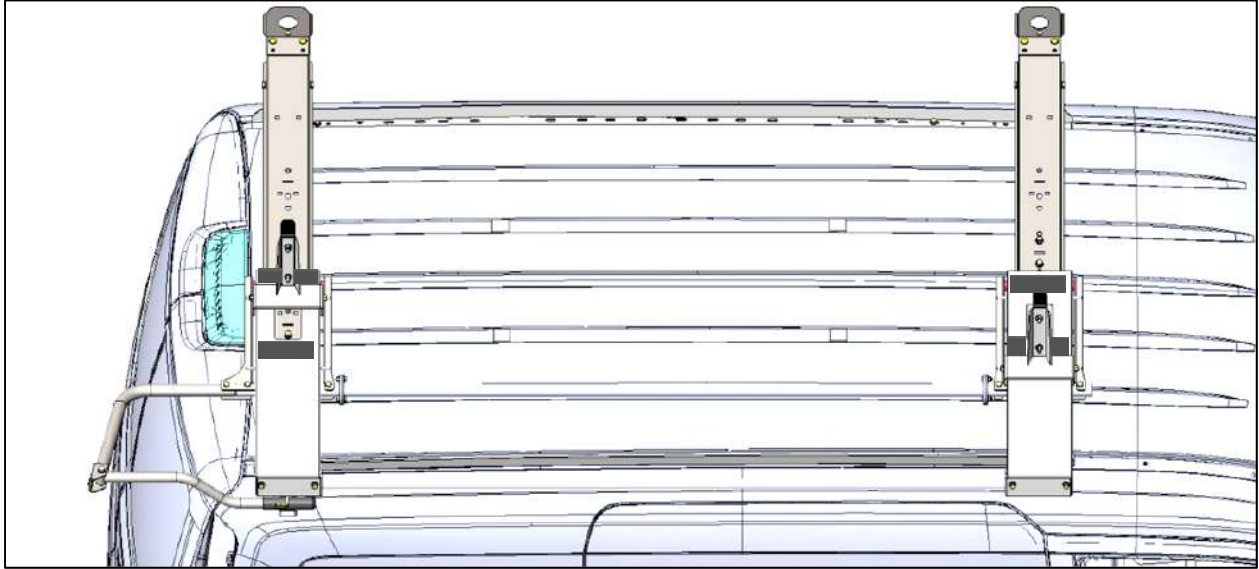

Installation complete for "extension ladder".

