

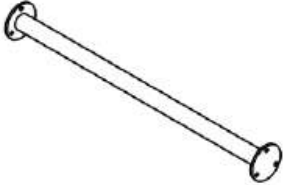

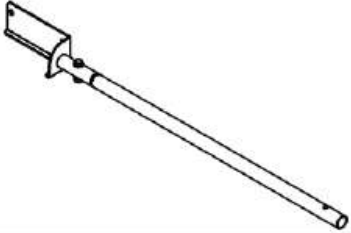





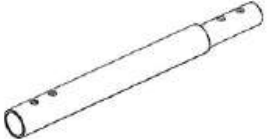

WE PUT EVERYTHING WITHIN REACH.

Installation Instructions

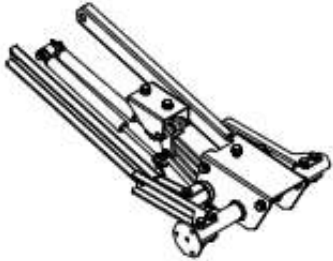
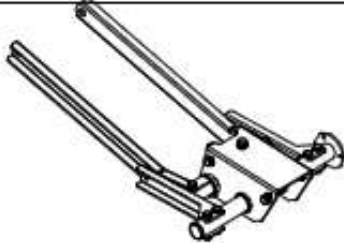
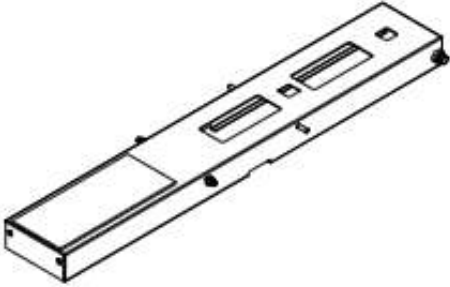
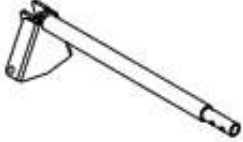
40913 Parts List

PART	PART NO.	QTY
	40993-25	1
	40993-831	1
	40900-31-R2	2
	40900-30-004	2
	spring	1
	40993-40-002	1

PART	PART NO.	QTY
	40993-08	1
	40993-09	1
	40993-10	2
	40993-45	1
	40993-12	1
	40993-24	1
	40993-832	1

40913 Hardware List

Tools Needed

8' Tape Measure
1/4" Socket
5/16" Socket

1/4" End Wrench
5/16" End Wrench
Hammer

Hardware Pack

(a)
Qty 2 -
Rubber Bumper



(b)
Qty 10 -
5/16" Flat Washer



(c)
Qty 4 -
5/16" Lock Washer



(d)
Qty 3 -
5/16"-18 Nyloc Nut



(e)
Qty 4 -
5/16"-18 x 5/8" Hex Bolt

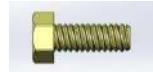

(j)
Qty 9 -
1/4"-20 x 7/8" Fully Threaded Hex Bolt



(k)
Qty 18 -
1/4" Flat Washer

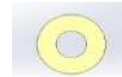

(l)
Qty 9 -
1/4"-20 Nyloc Nut



(m)
Qty 1 -
E6000

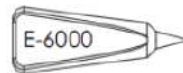

(n)
Qty 4 -
3/8" Nylon Washer



(q)
Qty 1 -
5/16"-18 x 1.5" Hex Bolt



(r)
Qty 2 -
5/16"-18 x 1.75" Hex Bolt



Step 1

Bolt "Dampener mounting bracket(40993-12)" underneath the crossbow (only the front side of the vehicle) as shown below using 3/8"x3/4 Bolts with flat and lock washers.

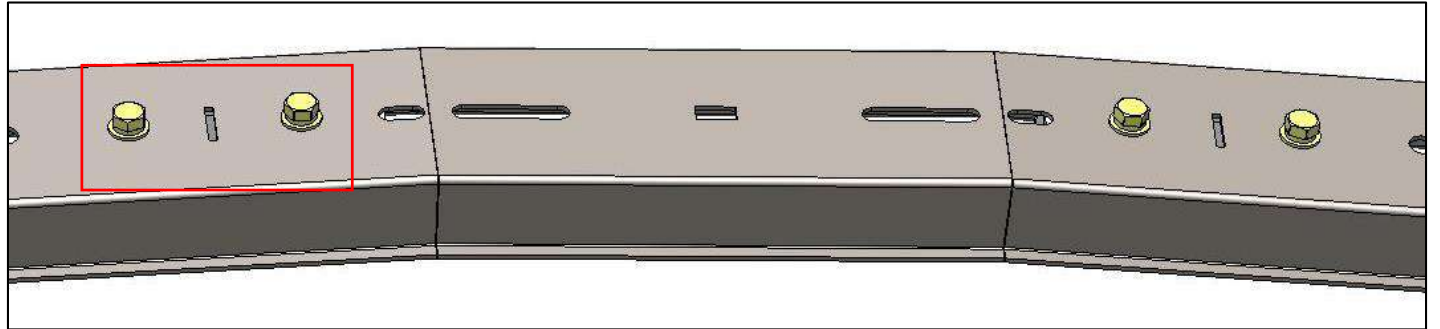
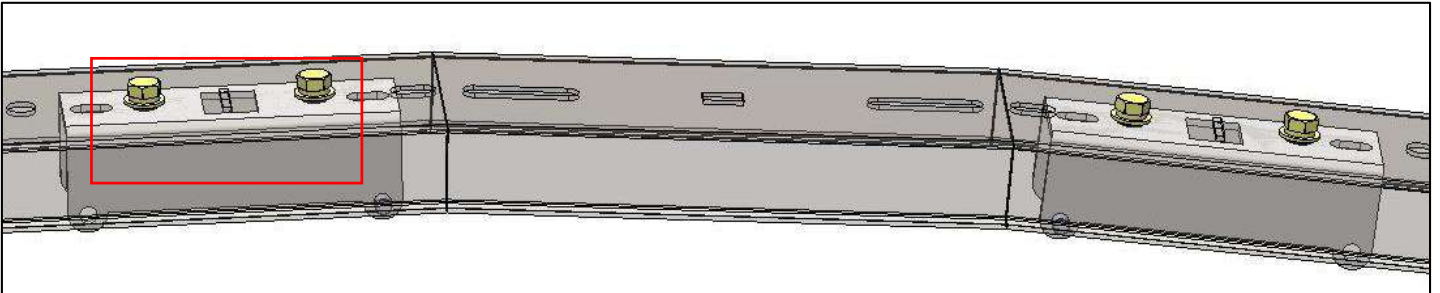
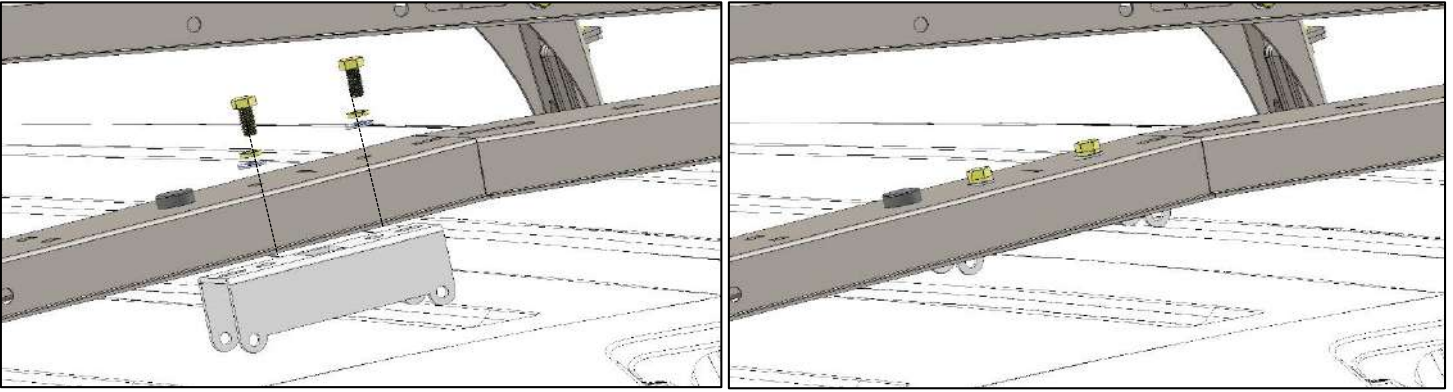

Step 2

Bolt "Torque tube pivot Assy. (40993-09)" underneath the front crossbow (Front side of vehicle) as shown below using 4 of 3/8"x3/4 Bolts with flat and lock washers. Repeat this step on the other side of the bow. You may need to un-bolt the mounting front from the crossbow to do this.

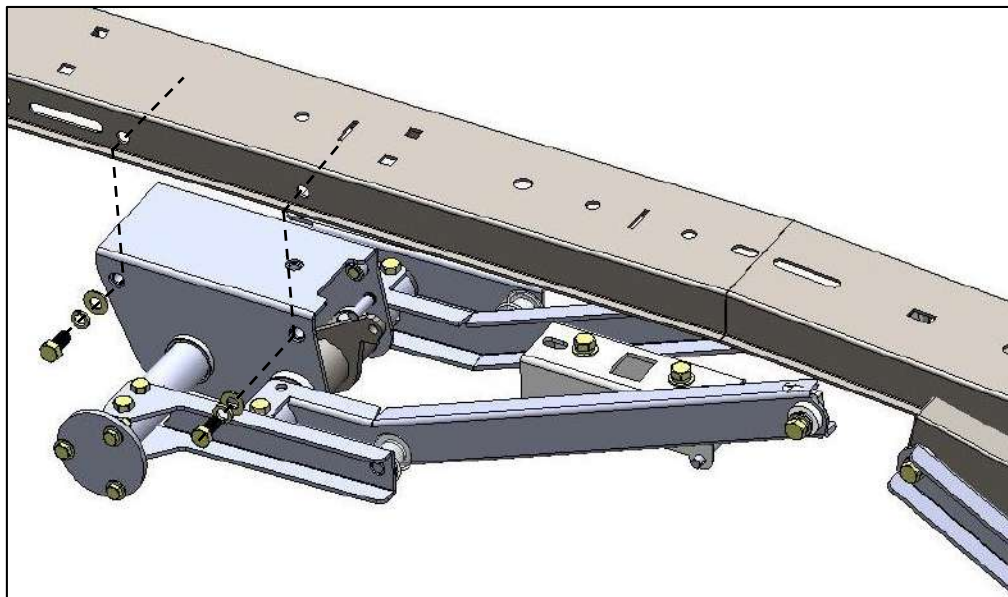

Step 3

Bolt "Torque tube pivot Assy. 2(40993-8)" underneath the rearcrossbow (rear side of the vehicle) as shown below using 3/8"x3/4 Bolts with flat and lock washers. You may need to un-bolt the mounting front from the crossbow to do this.

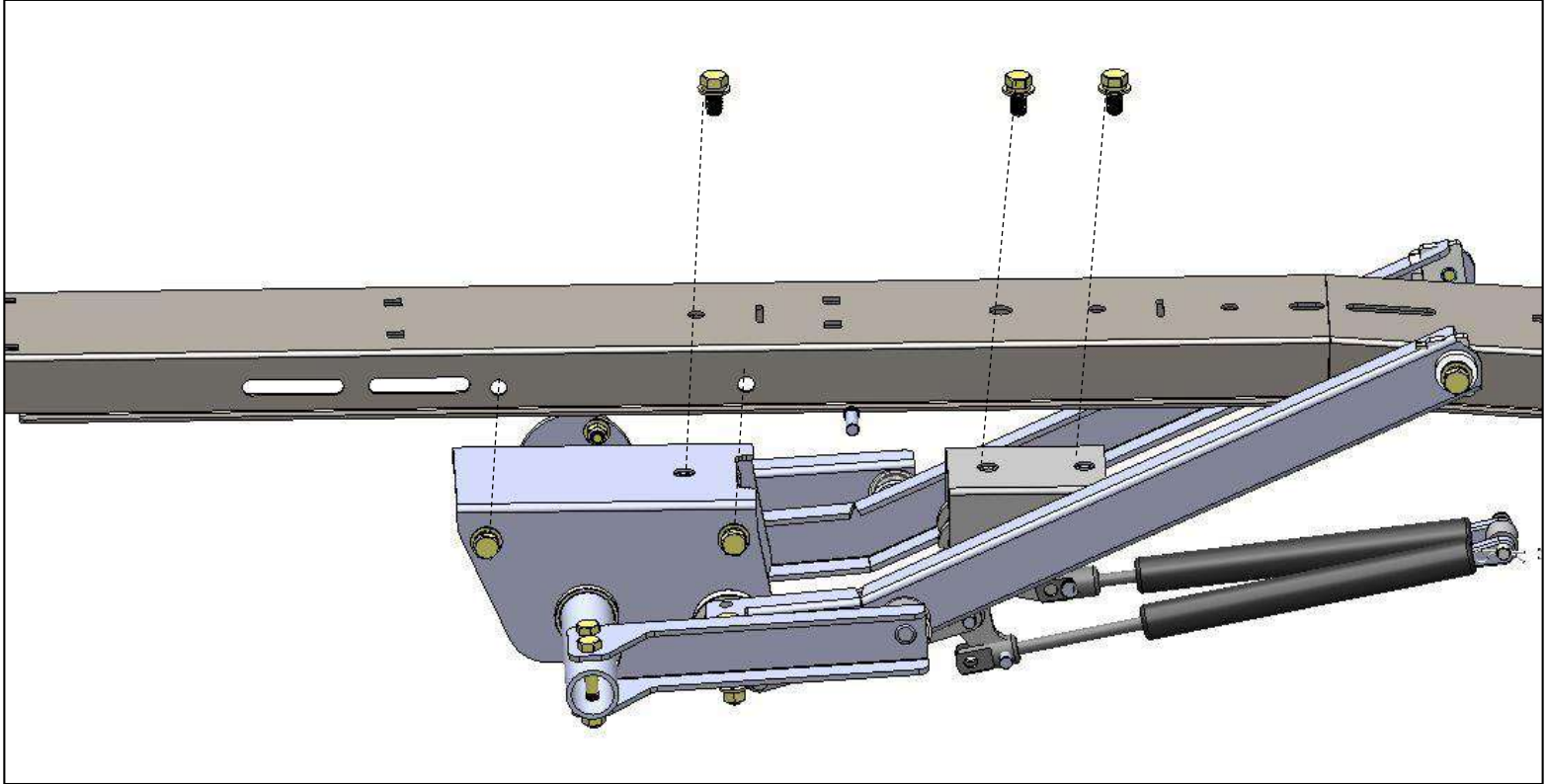

Step 4

Attach the open end dampeners to the center bracket using the 5/16"x2- 1/4" pin, sandwich the nylon spacer to secure the dampener in the middle of the bracket.

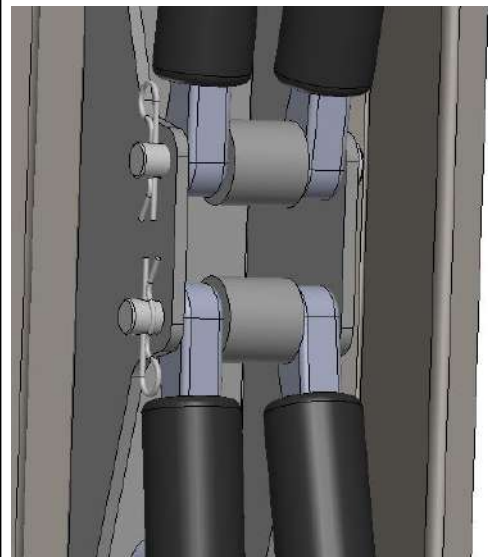
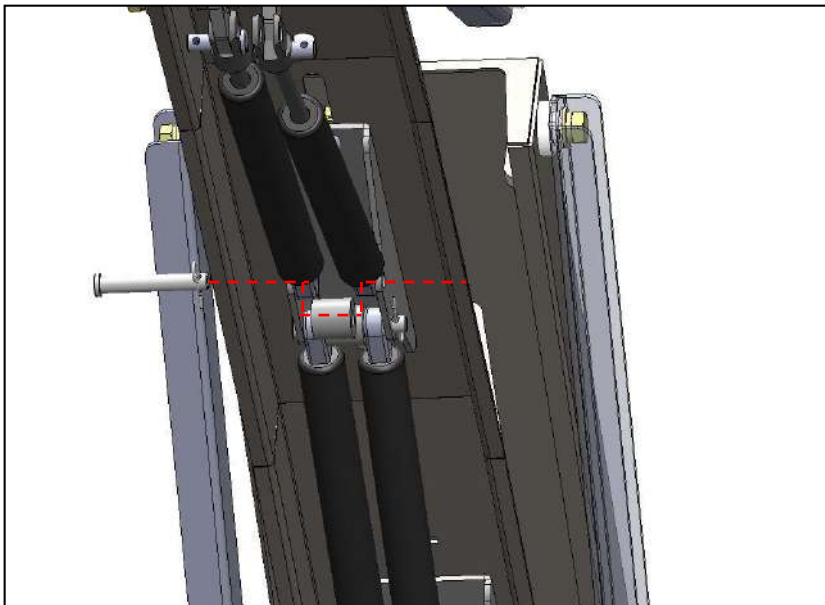

Step 5

Attach torque tube(40993-25 and 40993-24) using ¼" bolts (J) with flat washers(k) and nyloc nuts(l). Check distance between feet on both driver and passenger side, they must be EXACTLY the same to insure the bow assemblies are parallel.

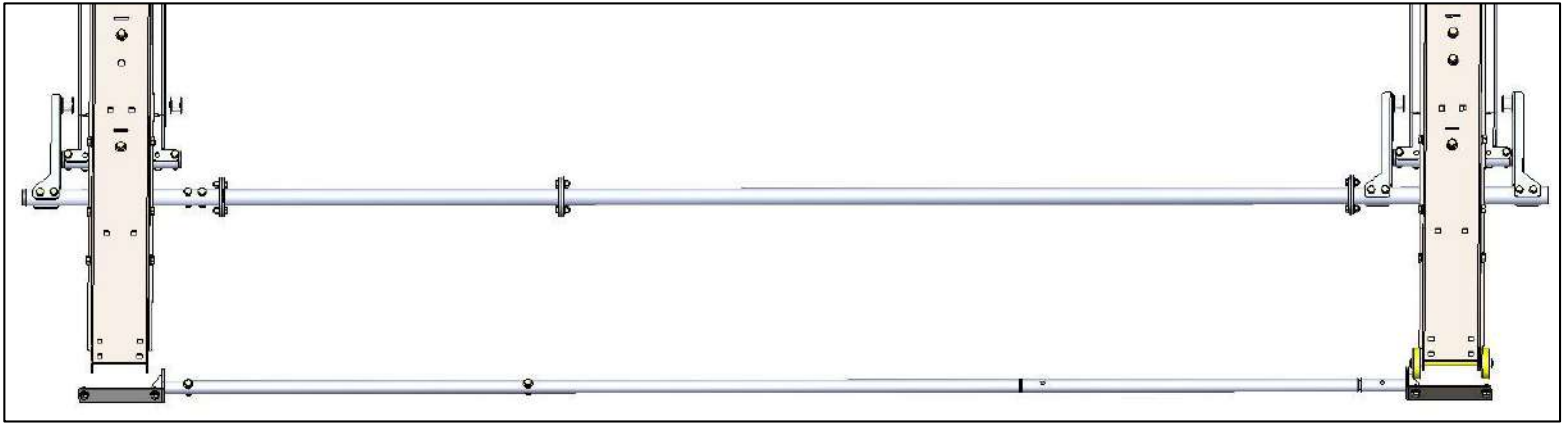
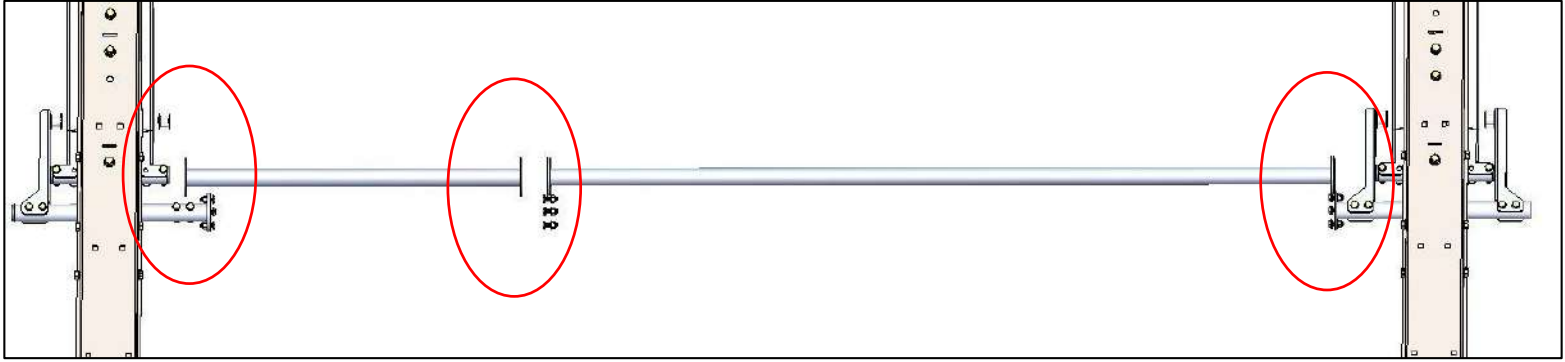

Step 6

Next install the "Axles" and "Rollers" at the end of both front and rear crossbow. The "Axle" just slides in and the "Rollers" slide over the ends of the "Axle" as shown below, make sure insert the nylon washers(n) between the wheels and crossbow.

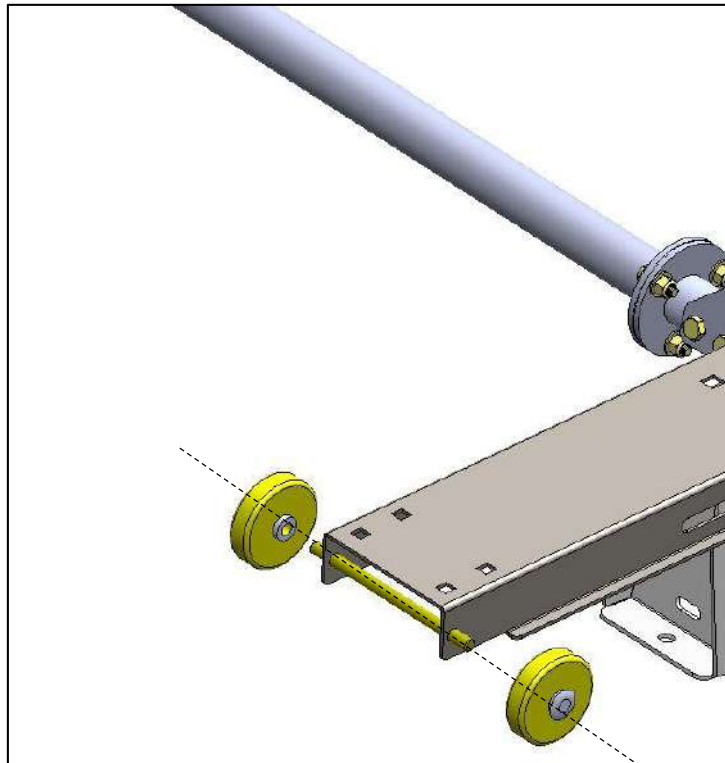

Step 7

Next install the "Ladder Pan Assy." Align cutouts in "Ladder Pan Assy.(40993-10)" with the "Rollers" and guide the arms onto the "Torque Tube Pivot Assy." As you lower the Pan assembly onto the rollers, remove the bolt assembly pre-installed on Ladder Pan, and use the same bolt assembly to secure the Arm with Ladder Pan. **Caution: Make sure the nylon spacer is sandwiched between the Arm and Ladder Pan, and lock washer or nyloc nut is used on this assembly.**

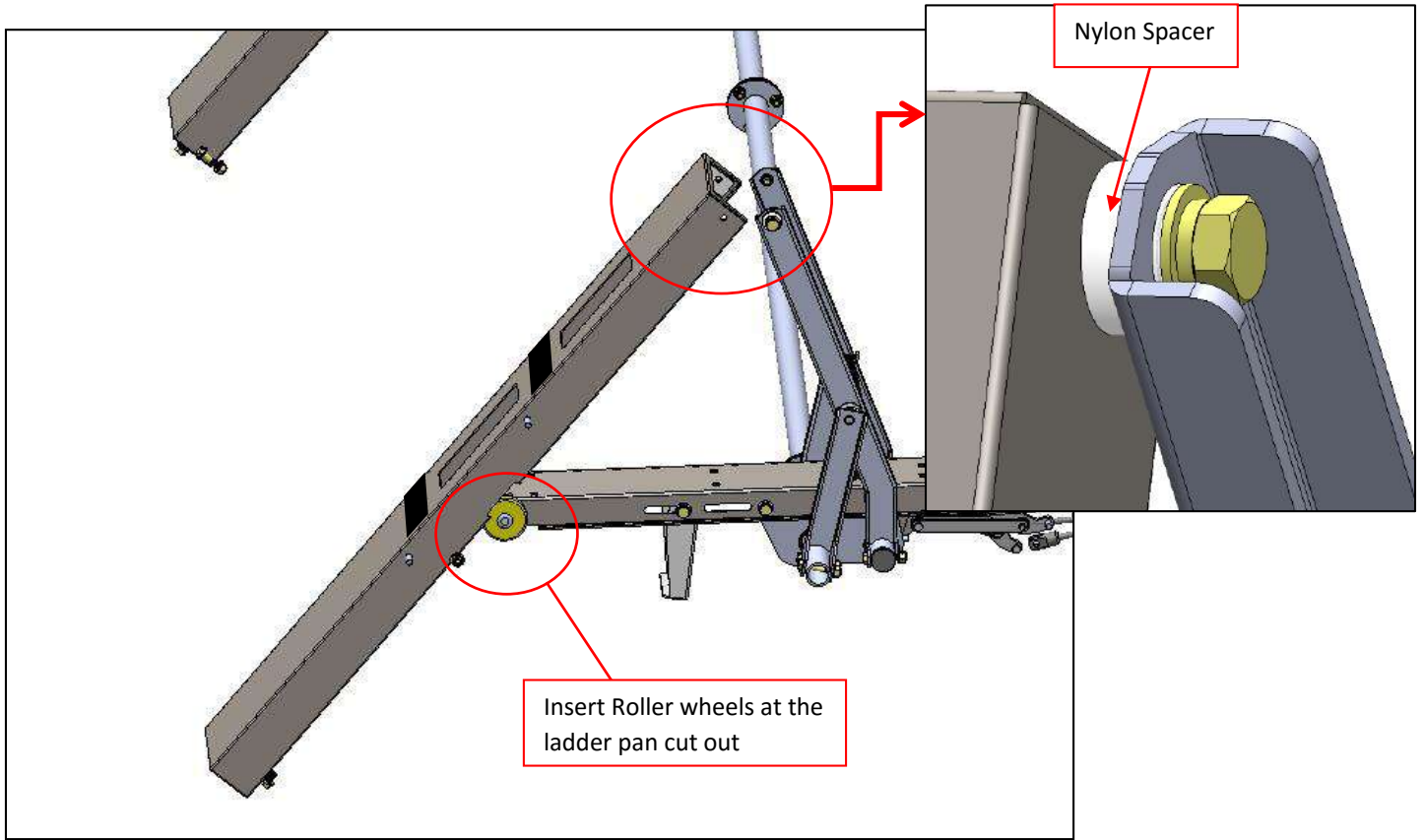

Step 8

Next attach the "Handle Assy. (40993-45)." as shown. **Optional:** If Handle Assy. does not extend far enough to clear rear vehicle, add the Extension Tube (40993-40-002) using 2 of 5/16" x 1.75" bolt (r), flat washer (b) and Nyloc Nut (d) to extend the Handle Assembly.

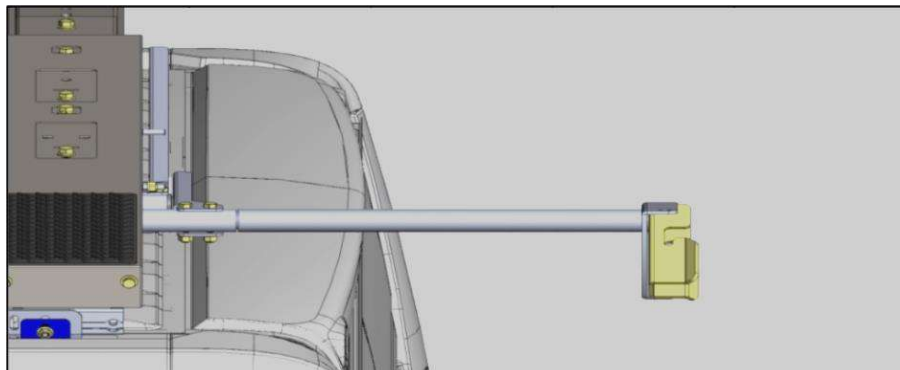
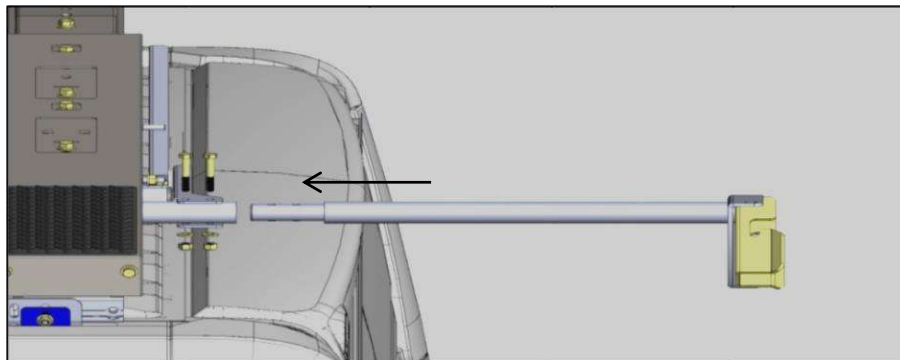

Step 9

Next attach the "Ladder Hooks (40800-31)" and "Ladder Stops (40900-30-004)". Attach "Ladder Hooks" to ladder pans on 5/16" studs in desired location. Attach "Ladder Stops" to coincide with "Ladder Hooks" by removing 3/8"x3/4" bolt and placing stop so the tab on the stop goes into the corresponding slot. If using a "step ladder" mount "Ladder Hooks" in the upper location in the rear. If you are using an "extension ladder" use the same location as the front bow.

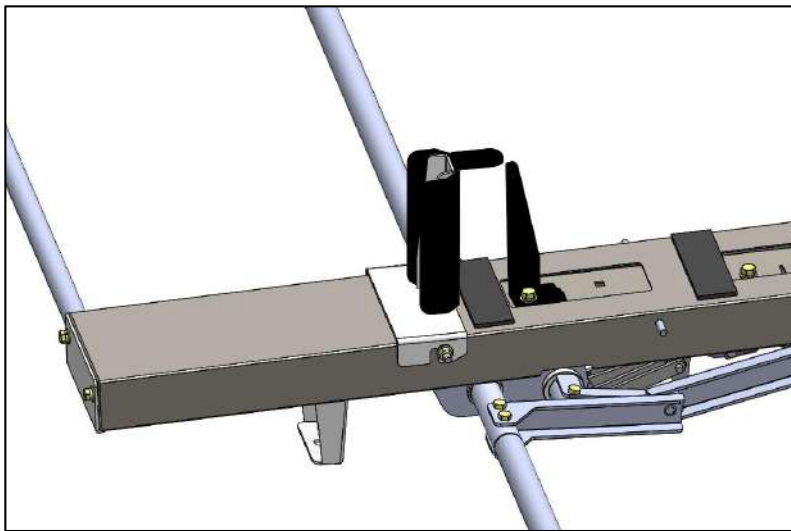
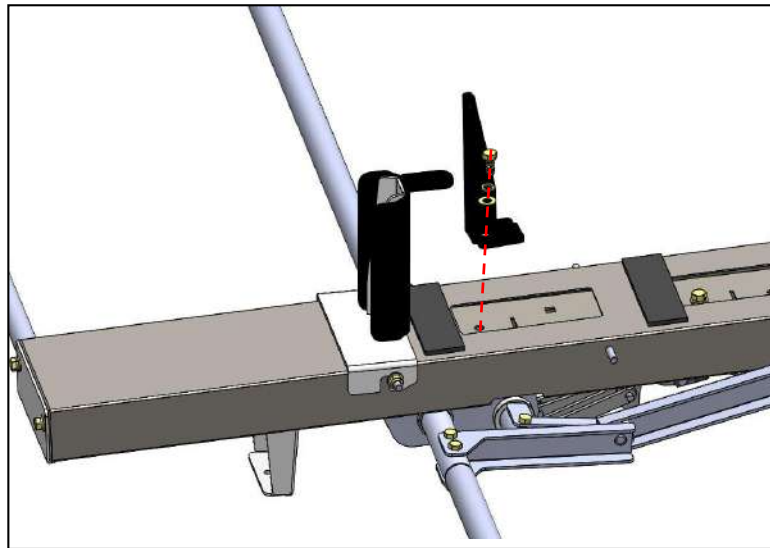
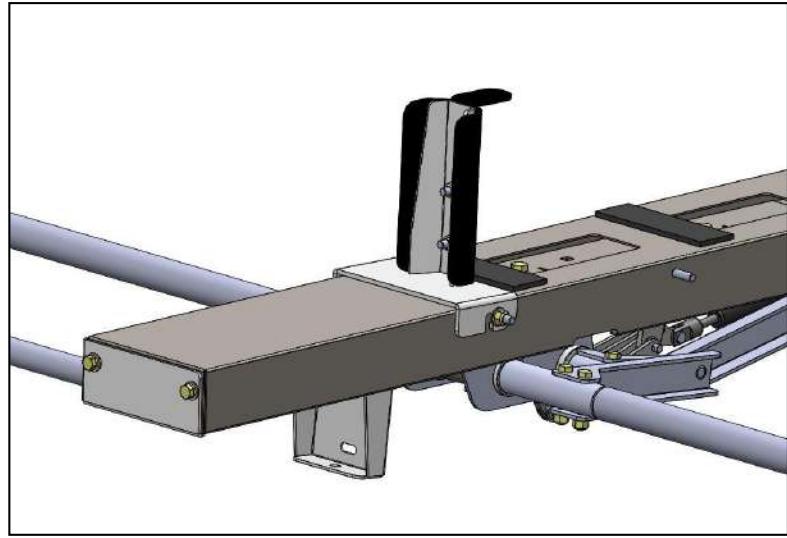
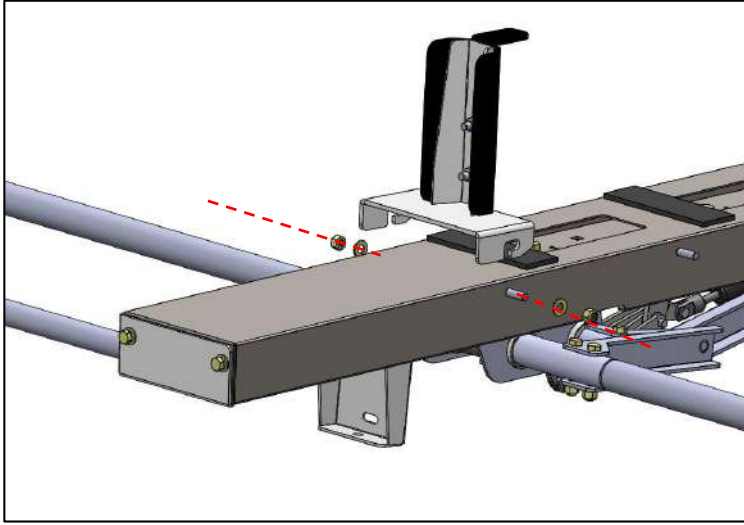

Step 10

First using 5/16"x1.5" Hex bolt (q) with two flat washers(b) and nyloc nut (d) to connect the ladder pan stiffener (40993-31 and 40993-832) and USE E6000(m) AROUND HOLES. Attach ladder pan stiffener, in the closed position, using 5/16"x5/8" bolts (e) with lock washers (c) and flat washers (b). Confirm that distance between passenger side feet and driver side feet are still EXACTLY the same. Now you can tighten the feet for the front and rear bow assemblies.

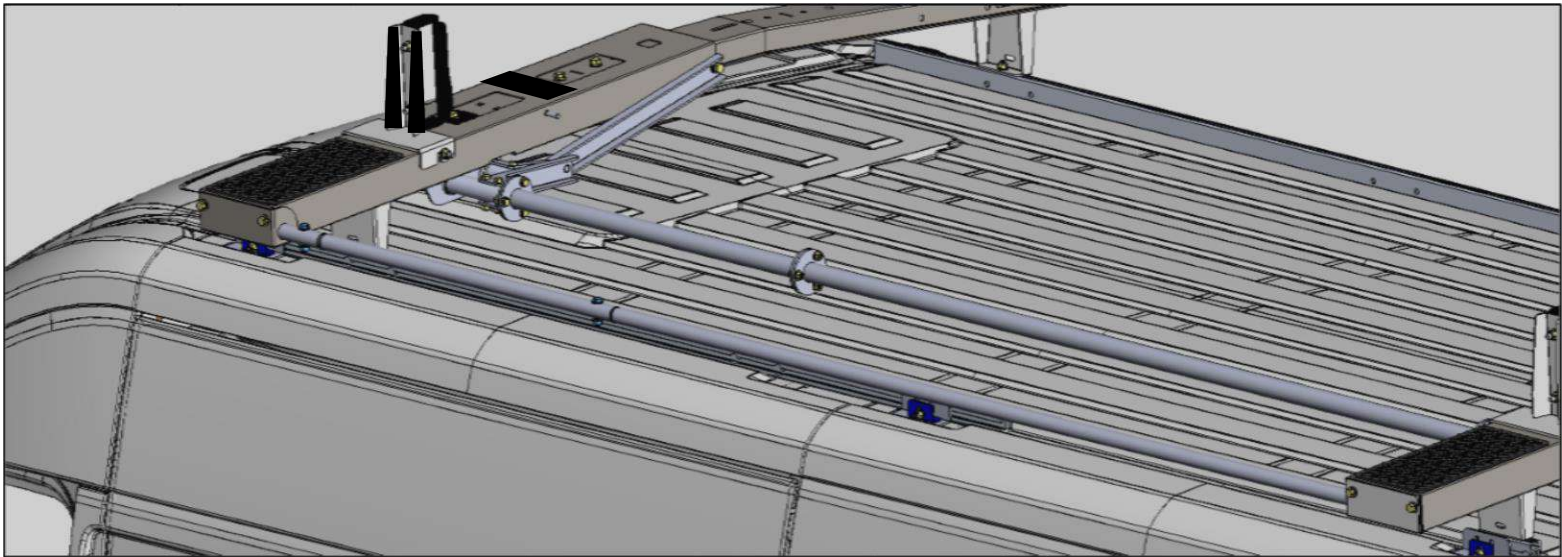
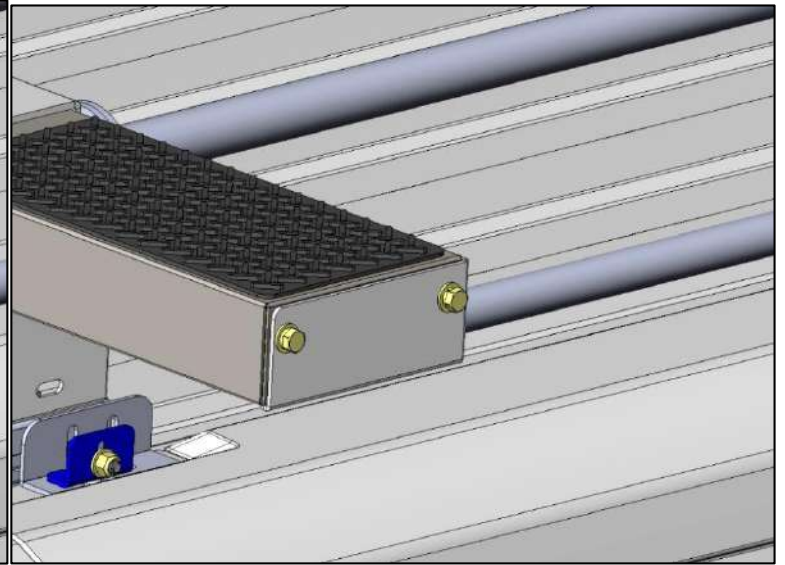
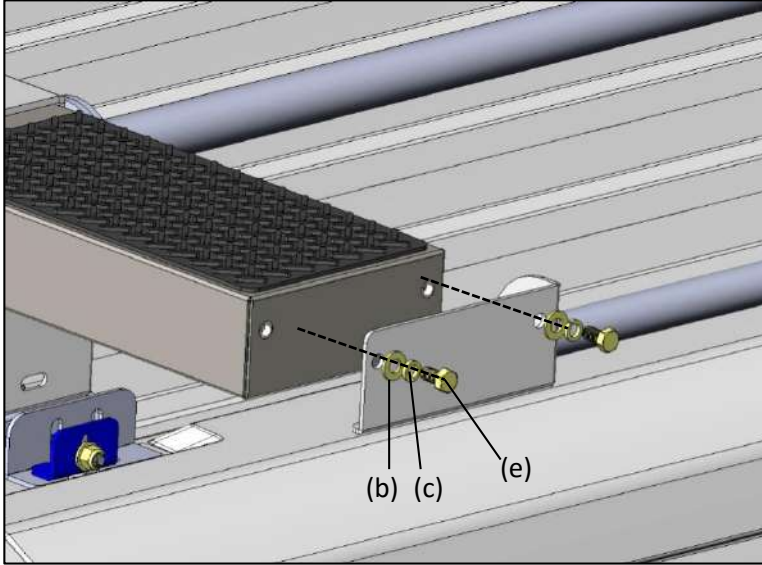

Step 11

Place the rubber bumper(a) to both front and rear crossbow as shown below.

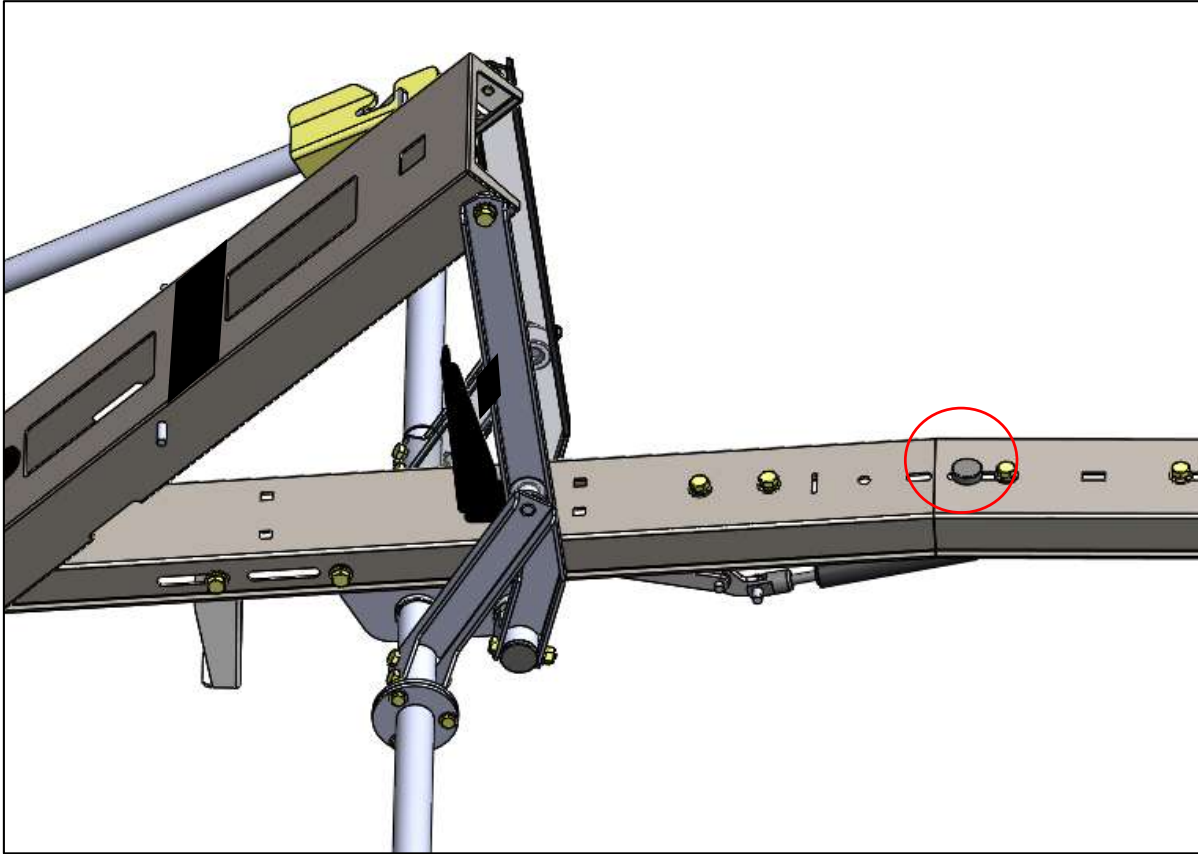

Installation is now complete.

