

KARGO MASTER®

WE PUT EVERYTHING WITHIN REACH.

Instruction Guide

406GM

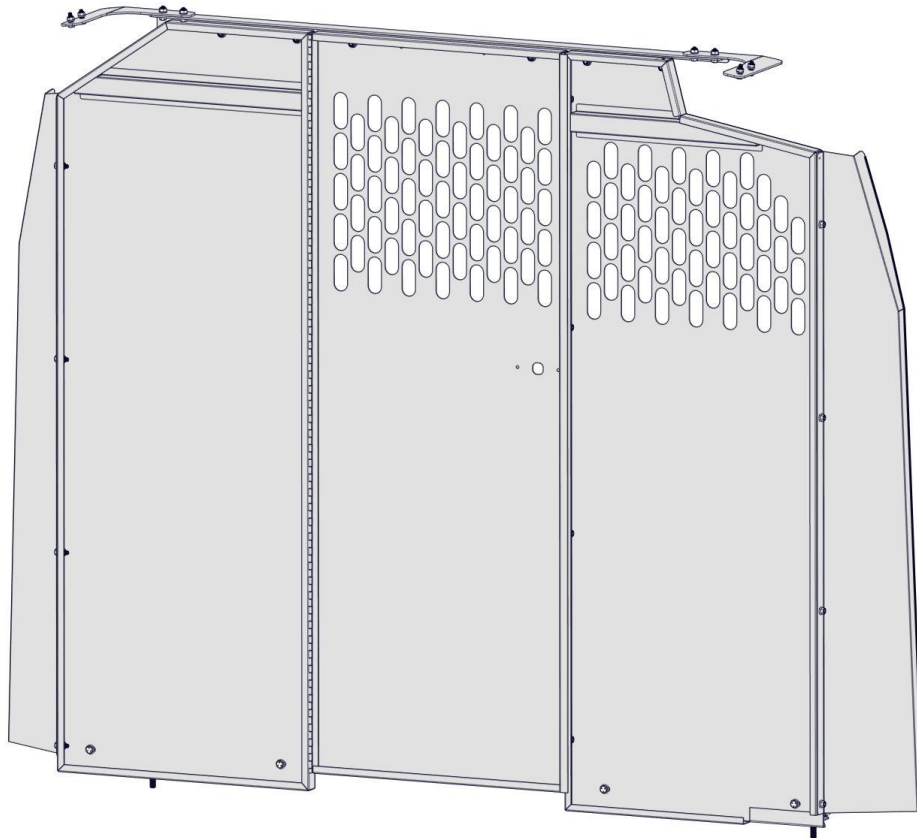

(partition shown for reference)

*PLEASE READ ALL INSTRUCTIONS AND WARNINGS PRIOR TO ASSEMBLING,
INSTALLING, AND USING THIS PRODUCT*

Warning



Always check for wires, fuel tanks and lines, brake lines and other important vehicle functionality items prior to drilling and installing all products.

Tools Needed

3/8" Wrench and Socket	7/16" Wrench and Socket
10mm Wrench and Socket	

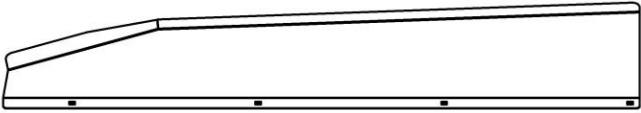
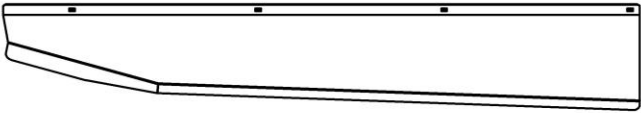



Table of Contents

Parts List3
Hardware List4
Step 1 Attach Side Wings5
Step 2 Install Upper Mount to Partition 6-7
Step 3 Install Floor Mounts8
Step 4 Install Upper Corner Mounts 9-10
Step 5 Attach Upper Mount to Partition11
Step 6 Attach Partition to Floor Mounts12





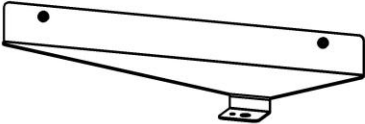
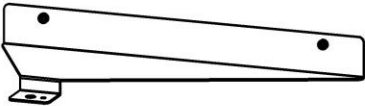

Before You Begin

- Read all instructions.
- Be sure to have a partition assembled and ready to be installed.

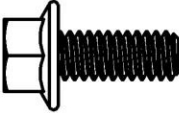
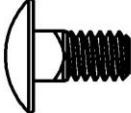
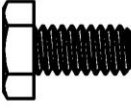
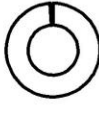
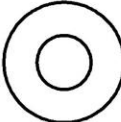
Parts

ITEM NO.		PART NUMBER	DESCRIPTION	QTY.
A		406GM-00-001	GM-Wing Panel PS	1
B		Mirror406GM-00-001	GM-Wing Panel DS	1
C		406GM-00-003	Upper Mount	1
D		406GM-00-004	GM-Upper Corner Mount DS	1
E		Mirror406GM-00-004	GM-Upper Corner Mount PS	1
F		406GM-10	GM-Floor Mount DS	1
G		Mirror406GM-10	GM-Floor Mount PS	1
		18-406GM-R1	Hardware Kit	1

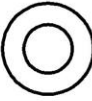
Hardware

ITEM NO.	TO SCALE	PART NUMBER	DESCRIPTION	QTY.
1		92979A114	1/4"-20 x 5/8" Flanged Hex Head	12
2		93548A530	1/4"-20 x 1/2" Carriage Bolt	6
3		92865A537	1/4"-20 x 1/2" Hex Head	4
4		91102A750	1/4" Split Lock Washer	4
5		90126A029	1/4" Flat Washer	4
6		93298A110	1/4"-20 Flanged Nyloc	18
7		91280A330	M6x1 x 20mm HH	4
8		91202A234	M6 Split Lock Washer	2
9		91166A250	M6 Flat Washer	8
10		90576A115	M6x1 Nyloc	4

Step 1 – Attach Side Wings

- Bolt both wings to the outer edges of partition in the orientation shown using 1/4" x 5/8" flanged hex head bolts and 1/4" flanged nyloc nuts.

Note: The panel that has no holes, is the driver side of the partition.

- Position each wing so that maximum seat space is achieved when attaching to partition.
- Repeat for a total of 8x.
- Snug tighten, but allow movement.

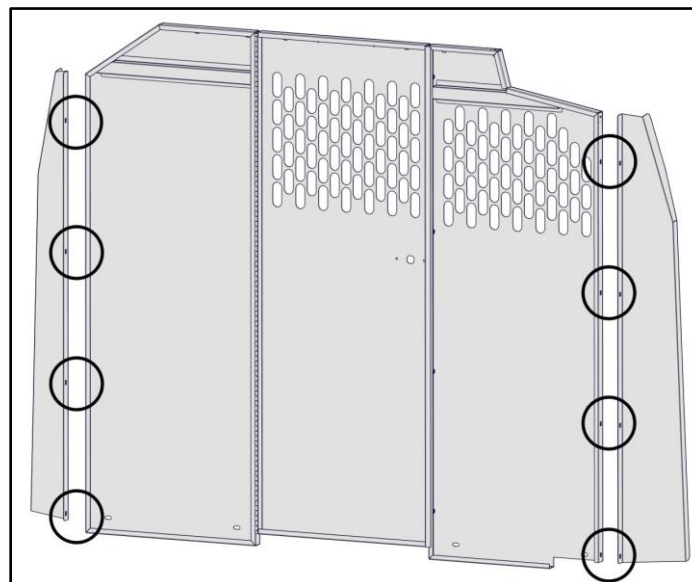
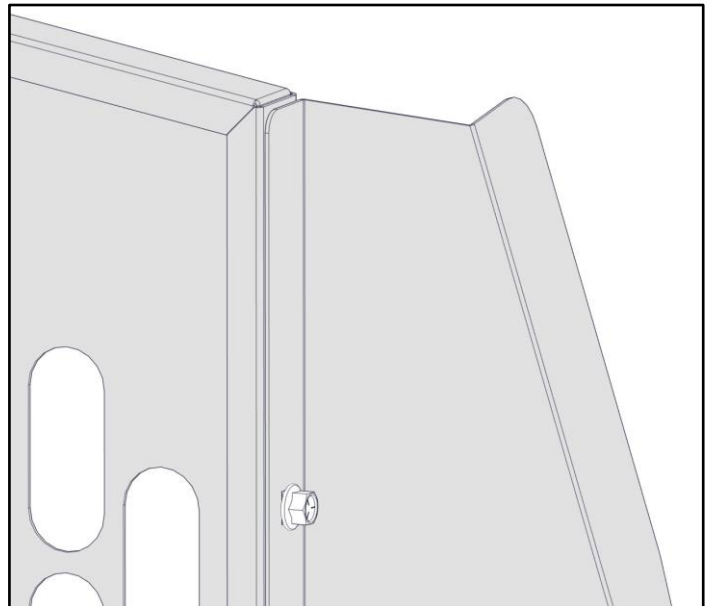
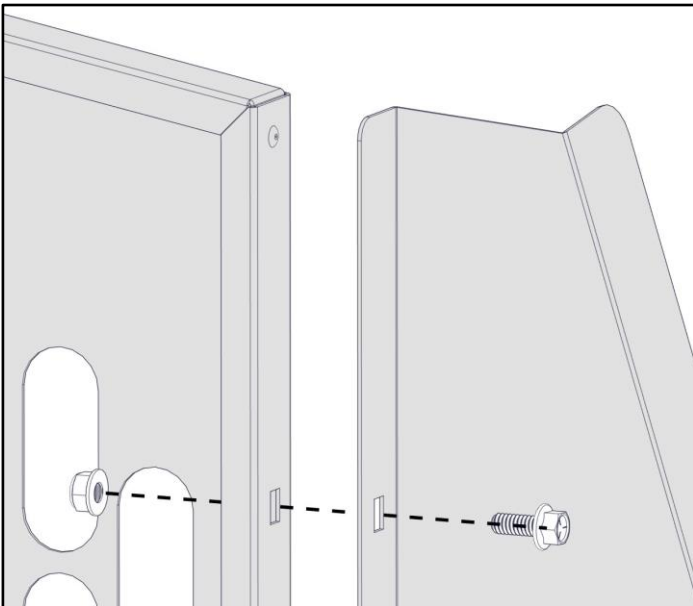
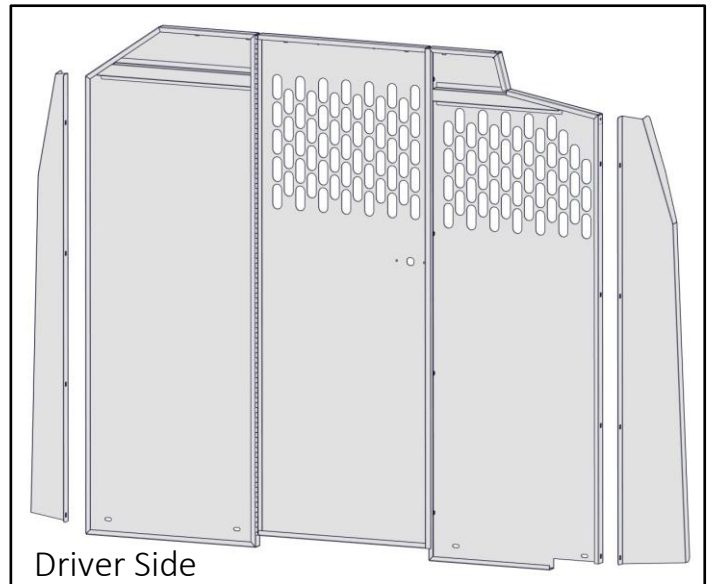

Step 2 – Install Upper Mount to Partition

- Place the upper mount against the partition assembly with the wing panels.
- Bolt the upper mount to the partition in the orientation shown using 1/4" x 1/2" carriage bolt and 1/4" nyloc nut. The head of the carriage bolt goes on the cab side.

Note: If using the pass through door, leave the hardware out of the two door locations.

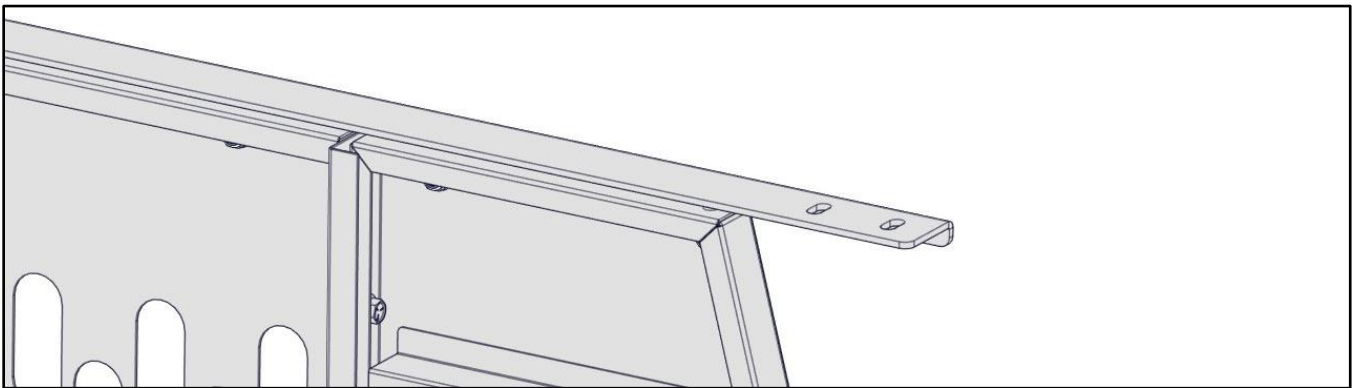
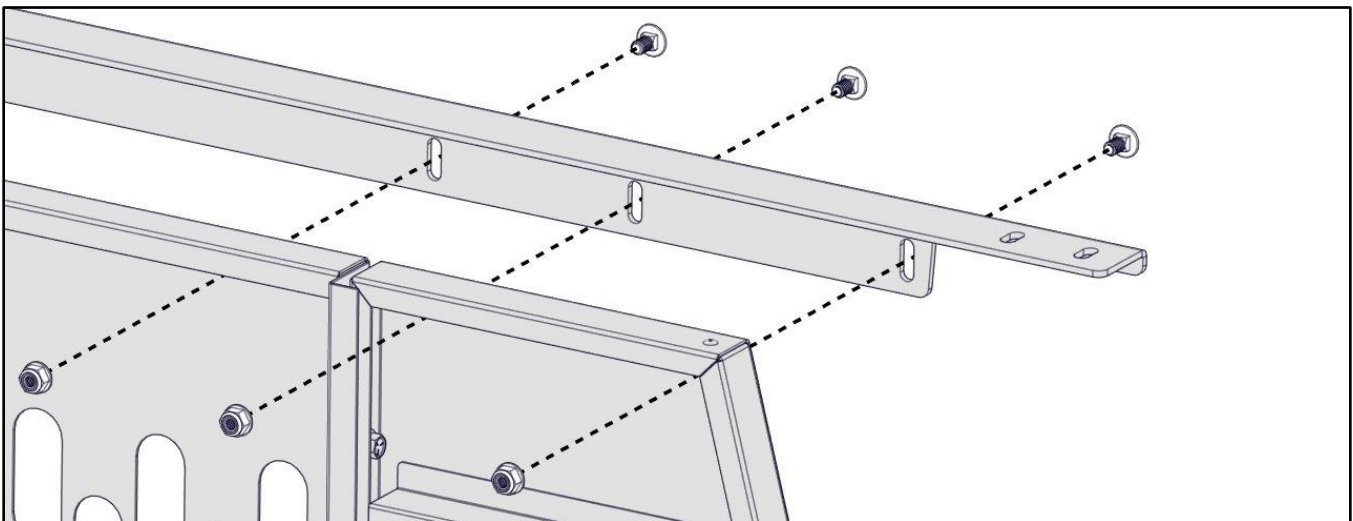
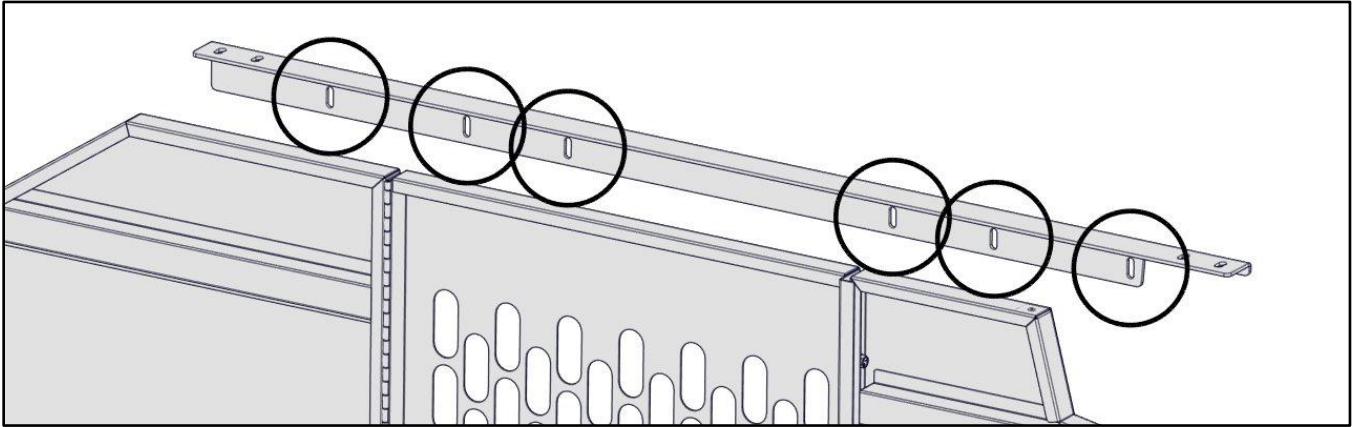

- Snug tighten, but allow movement.

Views shown below are from the cab side of the van.

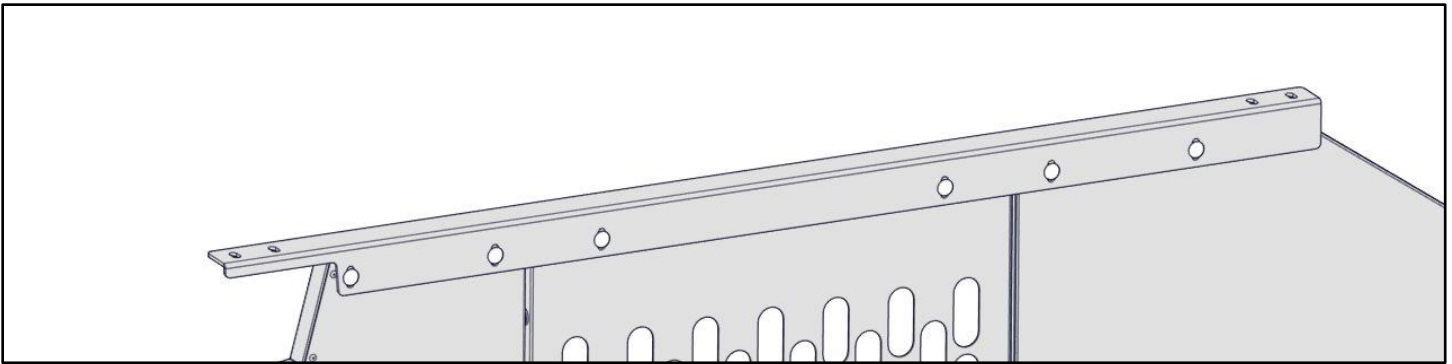
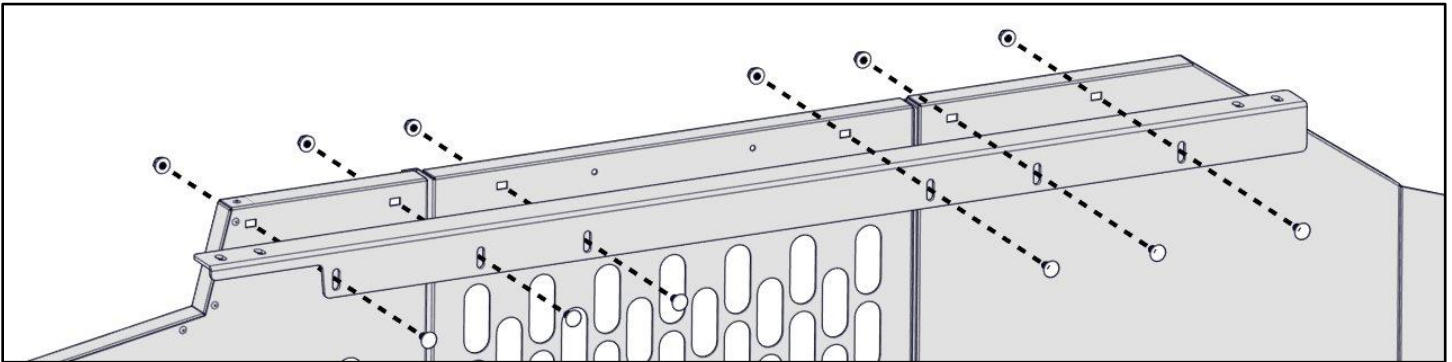

Step 3 – Install Floor Mounts

- Behind both seats, locate the D-Rings in the floor.
- Remove both D-Rings.
- Align the floor mounts with the previously removed D-Rings. Have the floor mounts oriented to the rear of the van.
- Install the floor mounts using the previously removed D-Rings as shown.

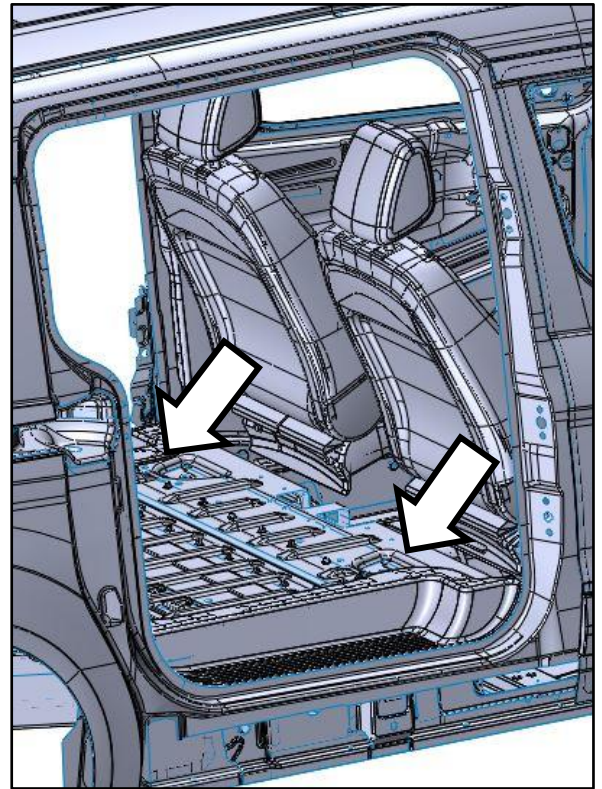

- Snug tighten, but allow movement.

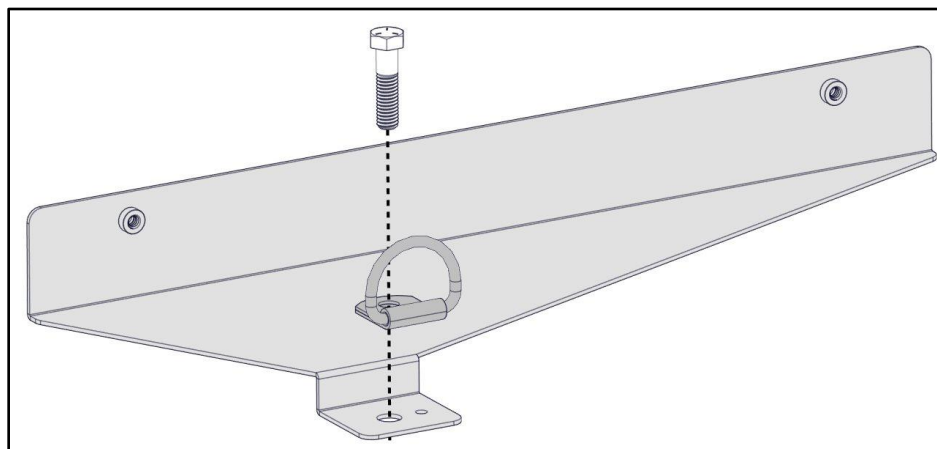

Step 4 – Install Upper Corner Mounts

- Along the roof of the van, locate the mount locations behind both seats. These are above the slider door.

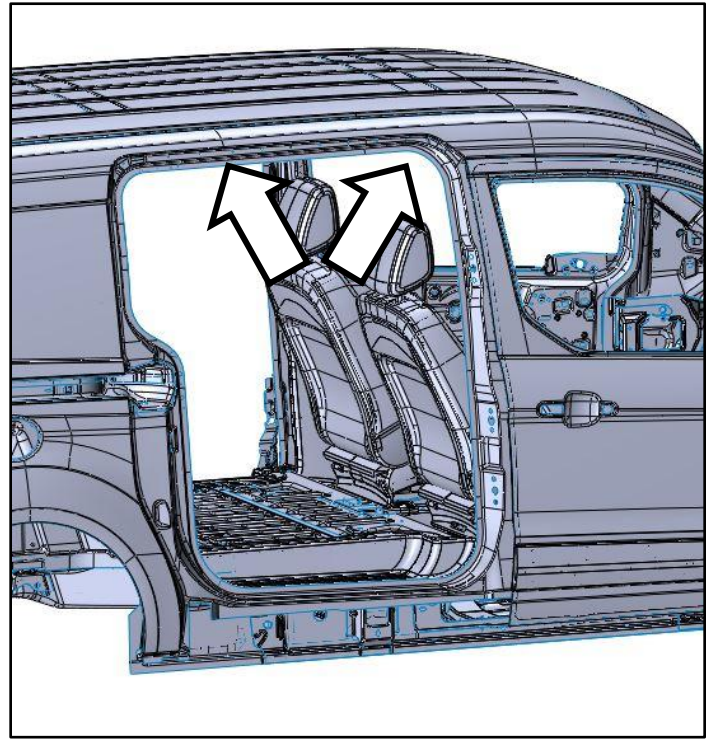

- Evaluate the mounting locations and determine if a threaded emboss is present.

Note: In some vans, a M6 threaded emboss will be attached (see picture above). The others will have two through holes.

- Be sure to use the correct upper corner mount. When the mount is attached properly, the flange should be towards the front of the vehicle and parallel to the floor. The slots in the upper corner mount will attach to the partition assembly.
- Through the rear most hole of the upper corner mount, attach in place using a M6 x 20mm hex head bolt, two M6 flat washers and a M6 nyloc nut in the orientation shown.
- Repeat on both sides.

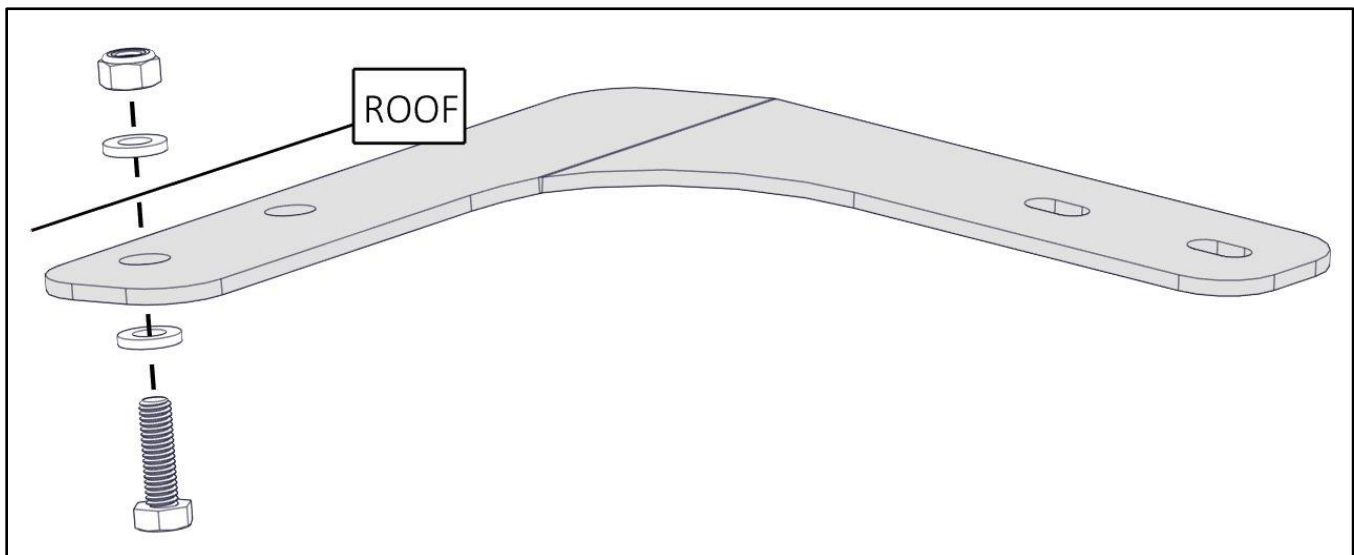

- If there is no threaded emboss on the forward most hole location, install using a M6 x 20mm hex head bolt, two M6 flat washers and a M6 nyloc nut in the orientation shown.

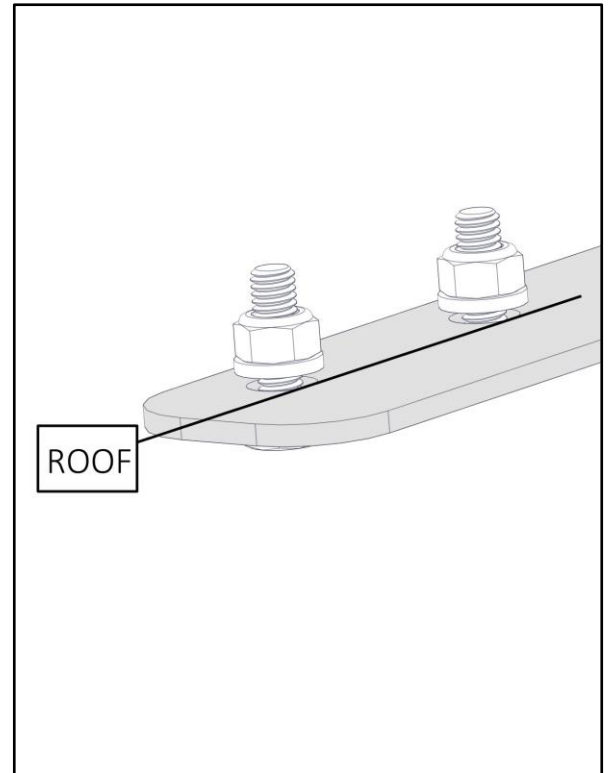
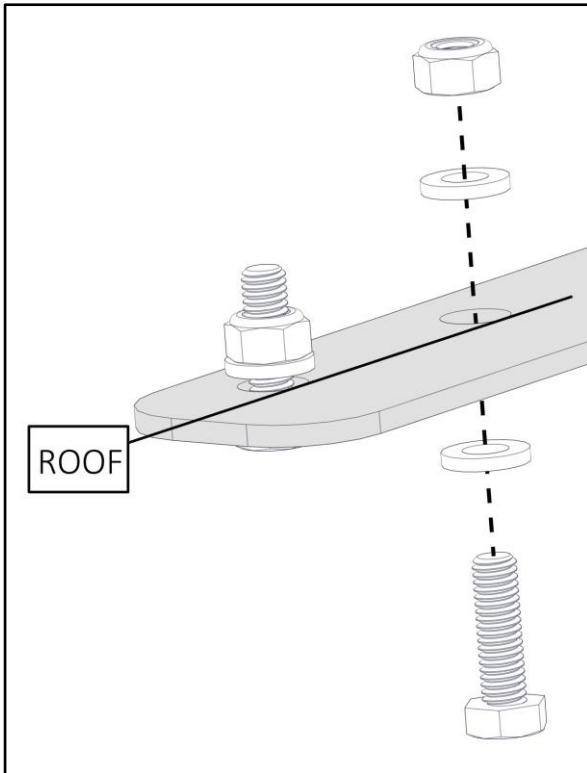

- If a threaded emboss is present, attach through the front most hole location using a M6 x 20mm hex head bolt, M6 lock washer and M6 flat washer as shown.

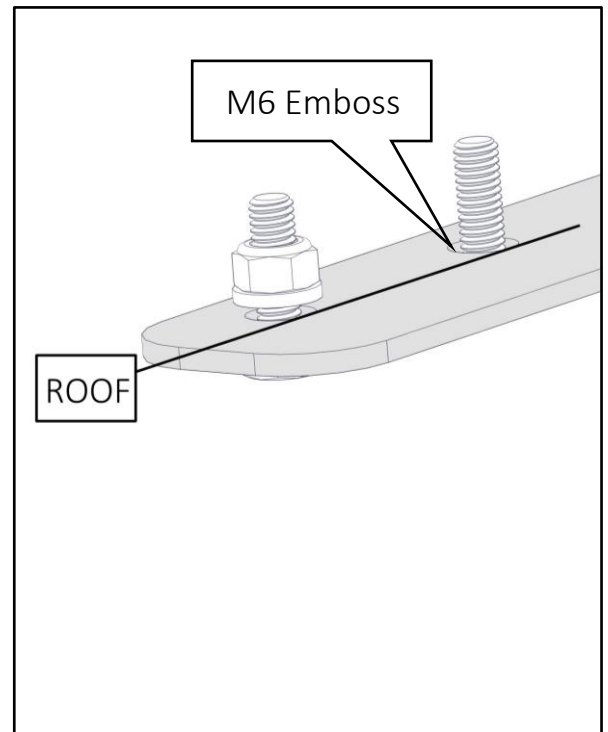
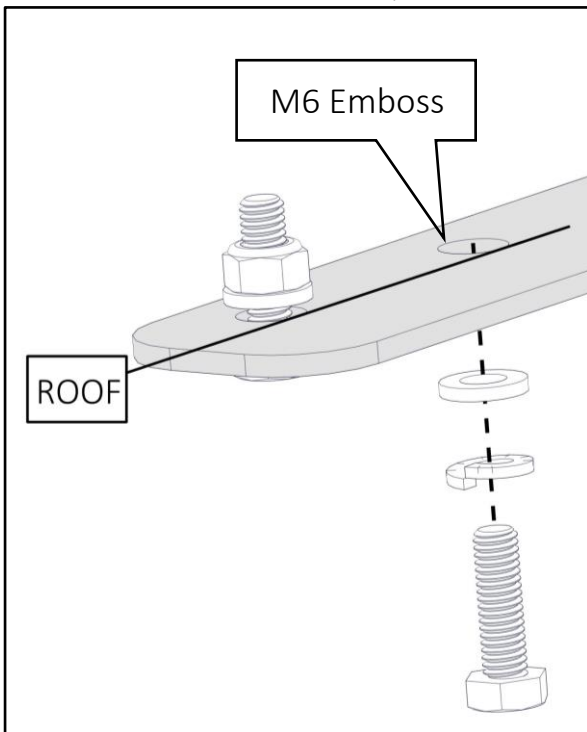

- Repeat on opposite side of the van.
- Snug tighten, but allow movement.

Step 5 – Attach Upper Mount to Partition

- Place the partition assembly into the van. Have the perforated panels of the partition on the passenger side. The bend in the wing panels will be directed towards the B pillar.
- Bolt the upper mount to both upper corner mounts using two 1/4" x 5/8" flanged hex head bolts and two 1/4" nyloc nuts in orientation shown. Be sure the bolts are facing upwards.

Note: Shown without some installed hardware and parts for simplicity.

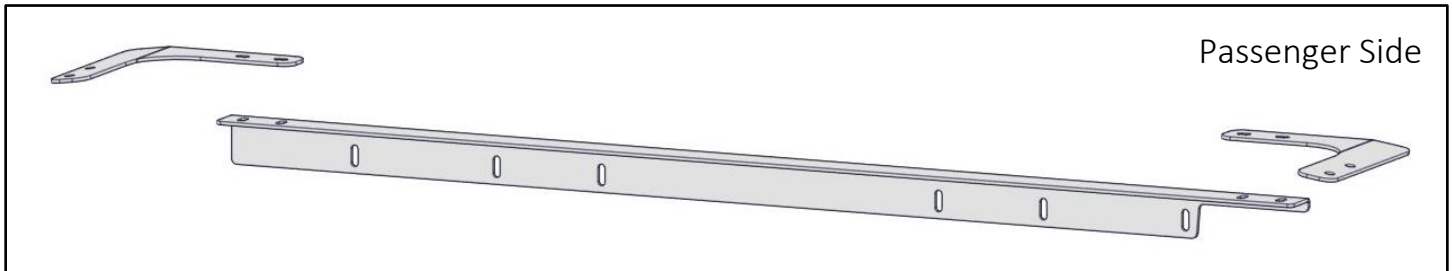

- Snug tighten, but allow movement.

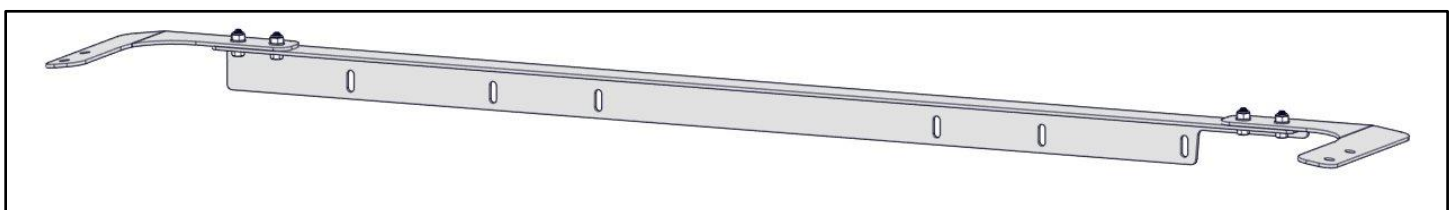
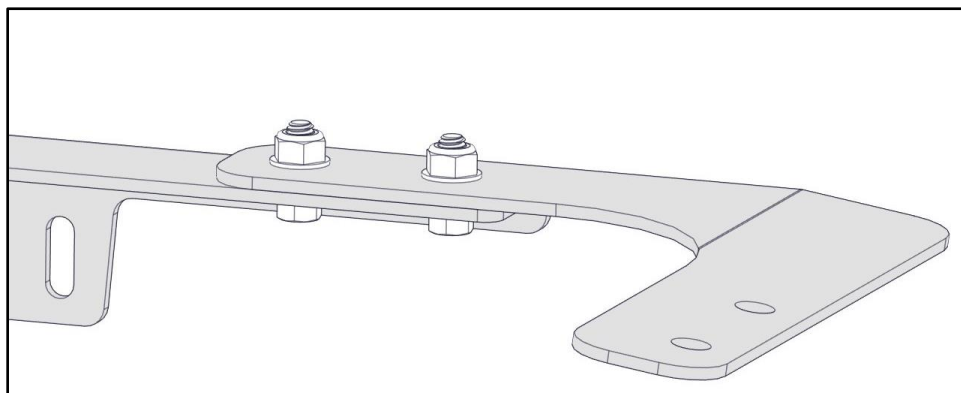
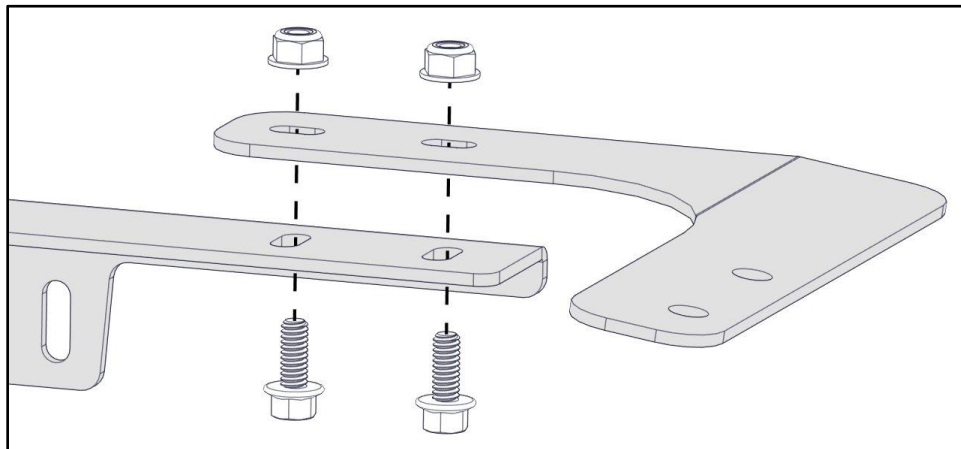

Step 6 – Attach Partition to Floor Mounts

- Locate the four mounting locations at the bottom of the partition.
- Align the four mounting holes with the previously installed floor mounts.



- Attach the partition assembly to the previously installed floor mounts using 1/4" x 1/2" hex head bolts, 1/4" lock washers and 1/4" flat washers.
- Repeat for a total of 4x.

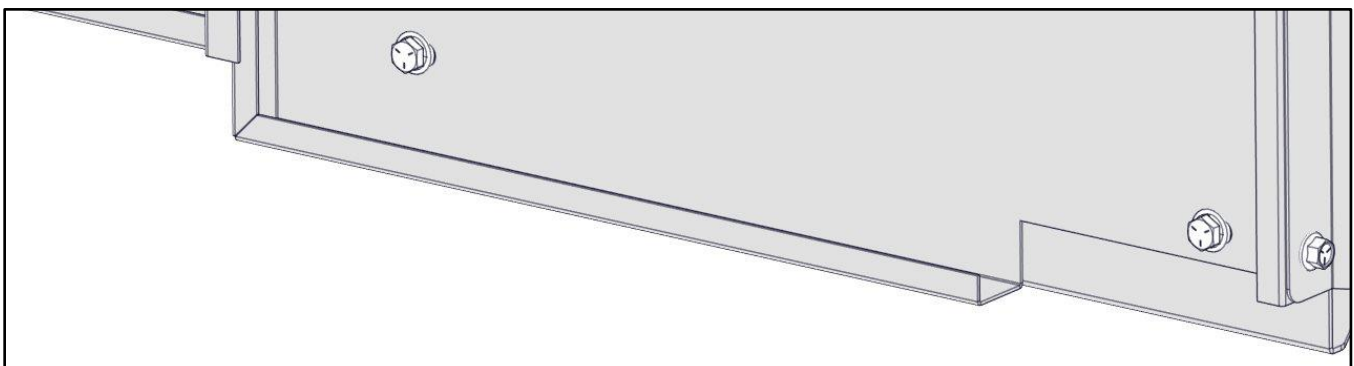
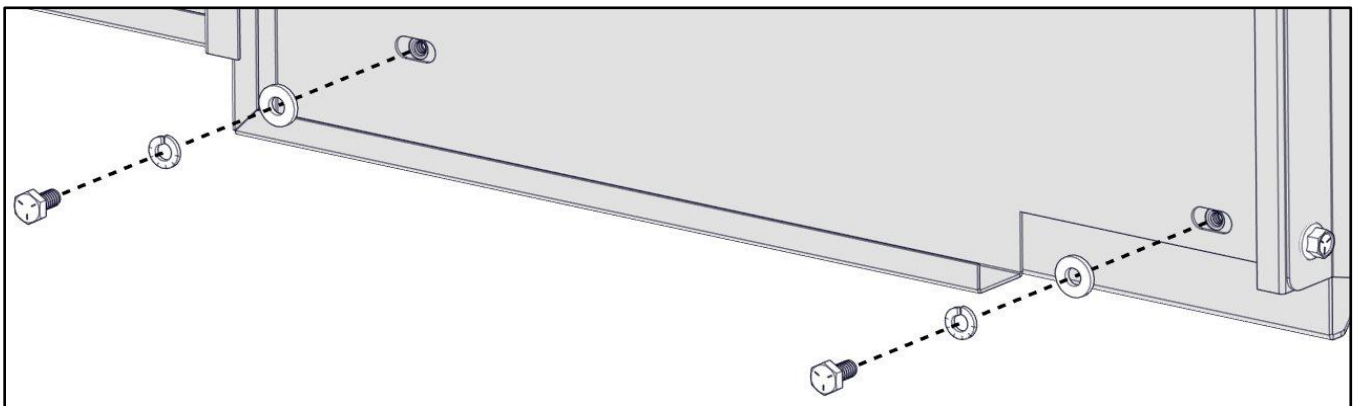

Align and square partition.

Go back and TIGHTEN all bolts including the bolts in the partition.

Installation is now complete.

