

KARGO MASTER[®]

WE PUT EVERYTHING WITHIN REACH.

Instruction Guide

40669TH

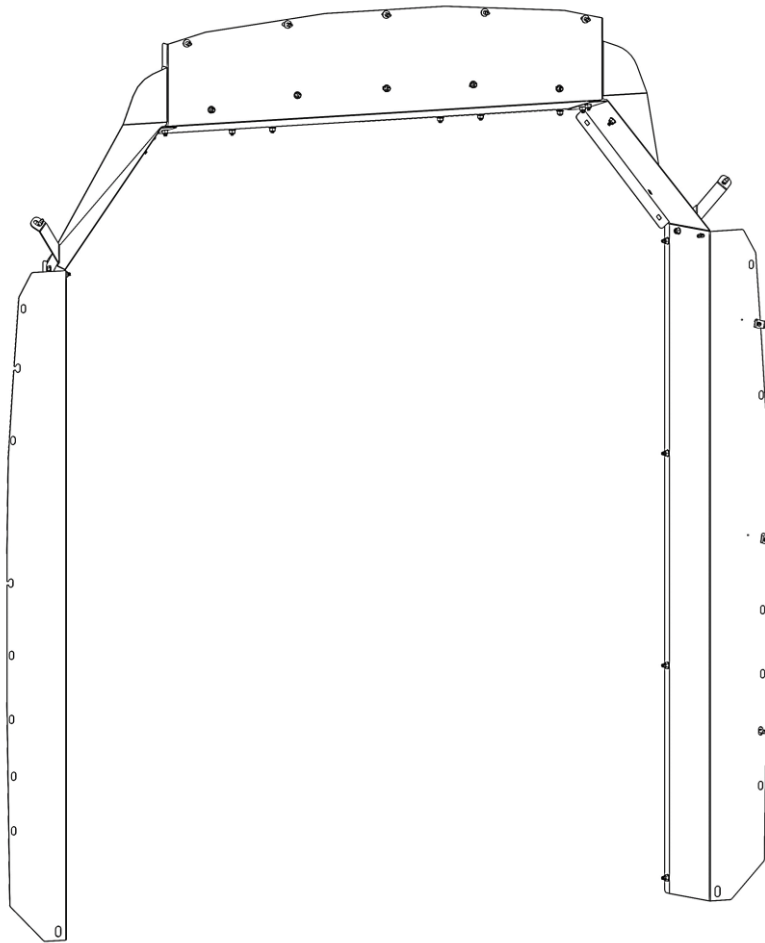

PLEASE READ ALL INSTRUCTIONS AND WARNINGS PRIOR TO ASSEMBLING, INSTALLING, AND USING THIS PRODUCT.

Warning



Always check for wires, fuel tanks and lines, air bags, brake lines, and other important vehicle functionality items prior to drilling and installing all products.

Tools Needed

3/8" Wrench and Socket	7/16" Wrench and Socket
1/2" Wrench and Socket	10mm Wrench and Socket
Drill	25/64" Drill Bit

Table of Contents

Before You Begin..... 1

Parts List..... 2

Hardware 3

Step 1 – Side Wings..... 4

Step 2 – Top Wing..... 4

Step 3 – Corner Panels..... 5

Step 4 – Corner Brackets..... 5

Step 5 – Corner Wing Panels..... 6

Step 6 – Top Wing..... 7

“B” Pillar Installation Notes 7

Step 7 – Installing Plus Nuts into Floor 8

Step 8 – Installing Driver’s Side Wing to “B” Pillar 9

Step 9 – Installing Passenger Wing to “B” Pillar 10





Step 10 – Installing Partition to Floor 10

Step 11 – Install Top Wing to “B” Pillar 11



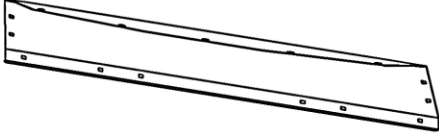
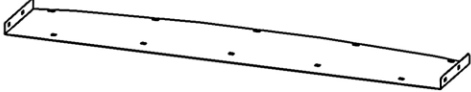
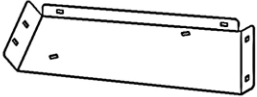
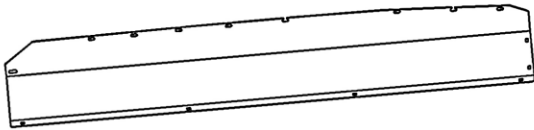
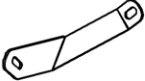
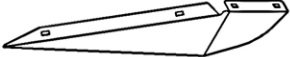

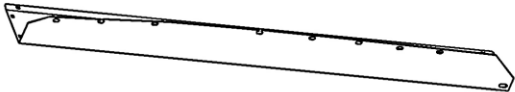

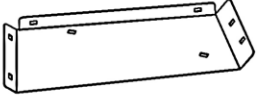

Before You Begin

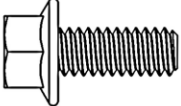
- READ ALL INSTRUCTIONS prior to installing any Kargo Master product.
- Be sure to have 40660 (Tall Partion) assembled and ready to be installed.

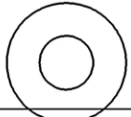
Parts List

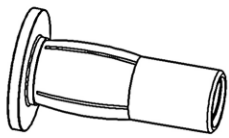
NO.	ITEM	PART NUMBER	DESCRIPTION	QTY.
1		100769	TRANSIT HR TOP PANEL	1
2		100795	TRANSIT HR TOP WING	1
3		100767	TRANSIT MR CORNER PANEL PS	1
4		406TH-10-001	TRANSIT MR PS WING	1
5		406TH-10-004	TRANSIT MR CORNER BRACKET RH PS	1
6		100765	TRANSIT HR CORNER PANEL-PS	1
7		100766	TRANSIT HR CORNER PANEL-DS	1
8		406TH-10-001-MIRROR	TRANSIT MR DS WING	1
9		406TH-10-004-MIRROR	TRANSIT MR CORNER BRACKET LH DS	1
10		100768	TRANSIT MR CORNER PANEL DS	1
11		18-100759	TRANSIT HR-HARDWARE	1

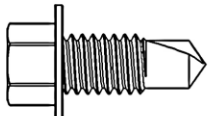
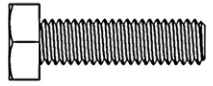
Hardware

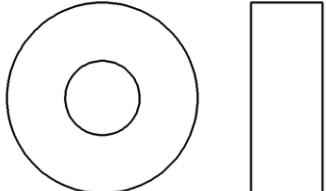
ITEM	HARDWARE TO SCALE	PART NUMBER	DESCRIPTION	QTY.
1		13800	1/4"-20 x 1-1/4" FT HEX HEAD BOLT	4
2		11126953	1/4"-20 X 5/8" FLANGED HEX HEAD	44
3		33618	1/4" LOCK WASHER	12
4		33078	1/4" WASHER	12
5		0167030	1/4"-20 FLANGED LOCK NUT	44
6		920313726	1/4"-20 Plus Nut	4
7		0143576	5/16" X 1" SELF TAPPING SCREW	5
8		0143575	5/16 X 3/4" SELF TAPPING	5
9		38566	M6 X 1 X 25MM HEX HEAD BOLT	8
10		0162878	M6 CLIP-ON U-NUT	2
11		11517442	3/8" ID X 1" OD X 3/8" NYLON SPACER	4

Step 1 – Side Wings

- Using four 1/4" x 5/8" flanged bolt and four 1/4" flanged lock nuts, bolt side wing to partition (40660).
- Snugly tighten.
- Repeat this step on opposite side partition.

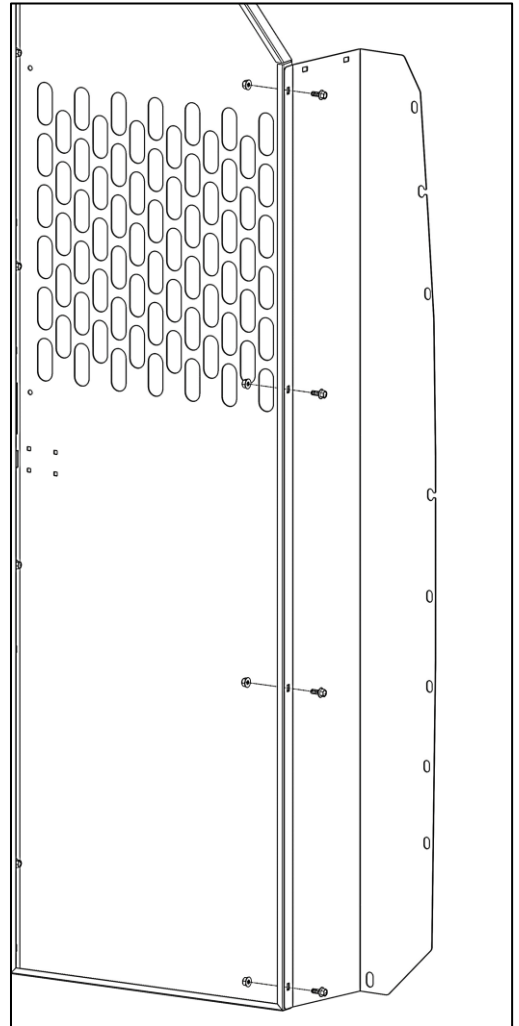
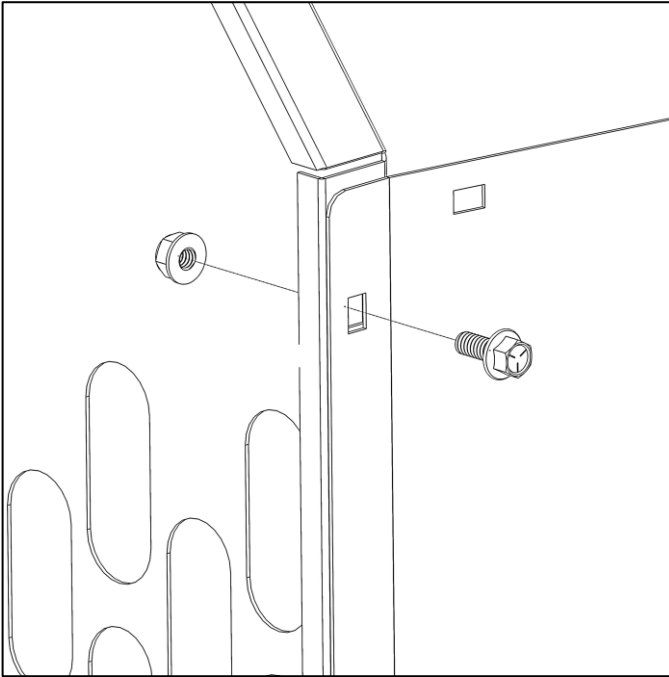

Step 2 – Top Wing

- Using six 1/4" x 5/8" flanged bolts and six 1/4" flanged lock nuts, bolt top wing to partition.
- TIGHTEN hardware.

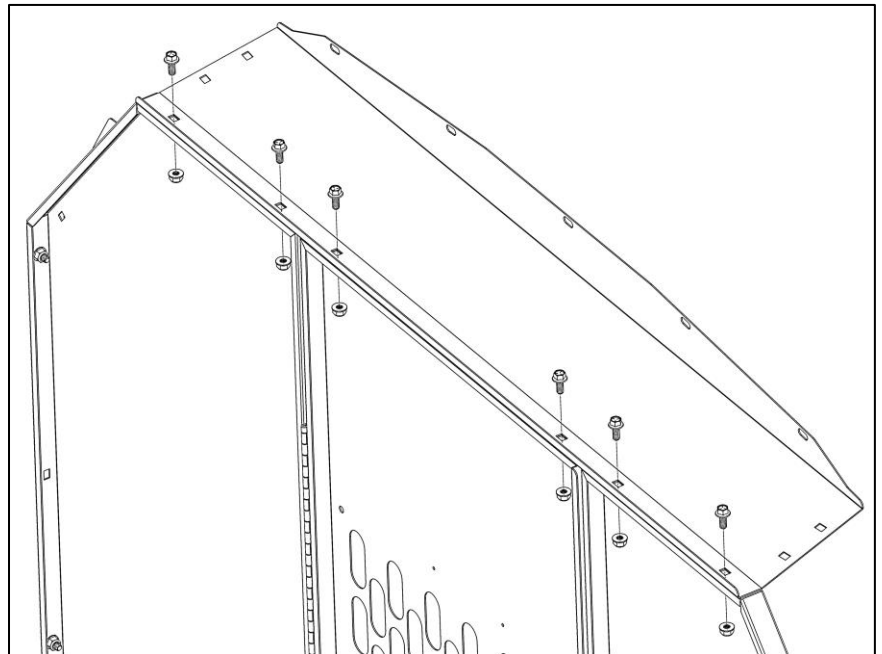

Step 3 – Corner Panels

- Using two 1/4" x 5/8" flanged bolts and two 1/4" flanged lock nuts, bolt corner panel to partition.
- Snug tighten.

- Using two 1/4" x 5/8" flanged bolts and two 1/4" flanged lock nuts, bolt corner panel to top wing.
- Snug tighten.

- Using two 1/4" x 5/8" flanged bolts and two 1/4" flanged locknuts, bolt corner panel to side wing.

NOTE: DO NOT install a bolt in the holes closest to the partition on each side wing.

- Snug tighten.

- Repeat this step on opposite side of partition.

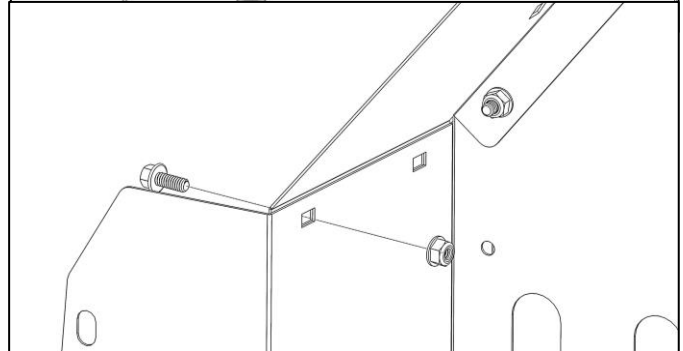
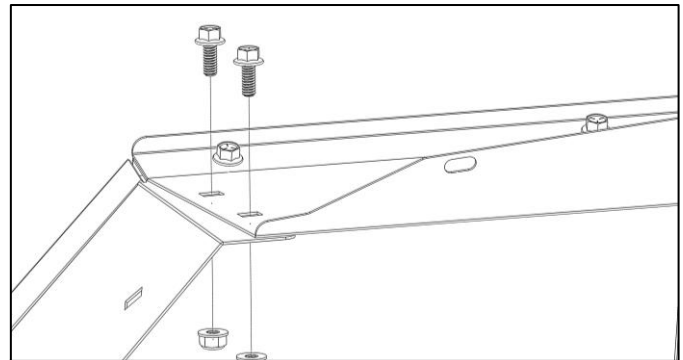
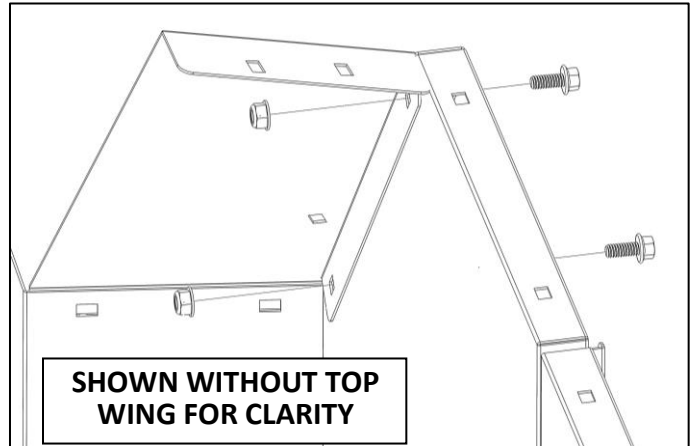

Step 4 – Corner Brackets

NOTE: The corner brackets are side specific. Verify the correct bracket position prior to installing.

- Using a 1/4" x 5/8" flanged bolt and a 1/4" flanged lock nut, bolt each mid roof corner bracket into the holes closest to the partition on each scornor of the partition as shown. The holes used to attach these brackets were the holes the bolt was left out in the previous step.
- Snug tighten.

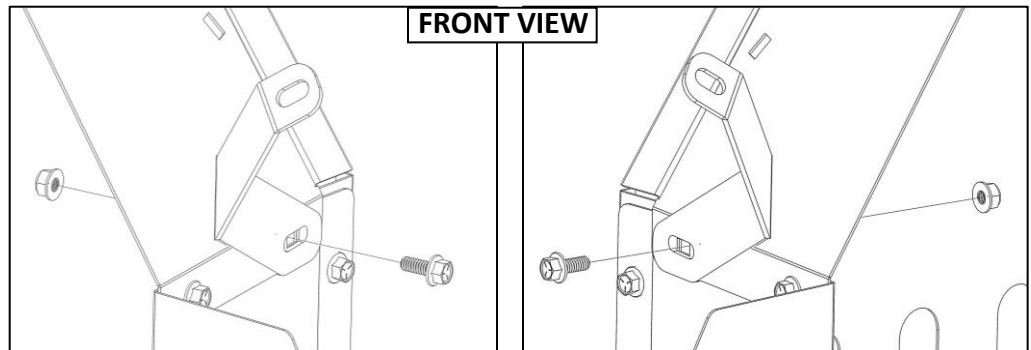

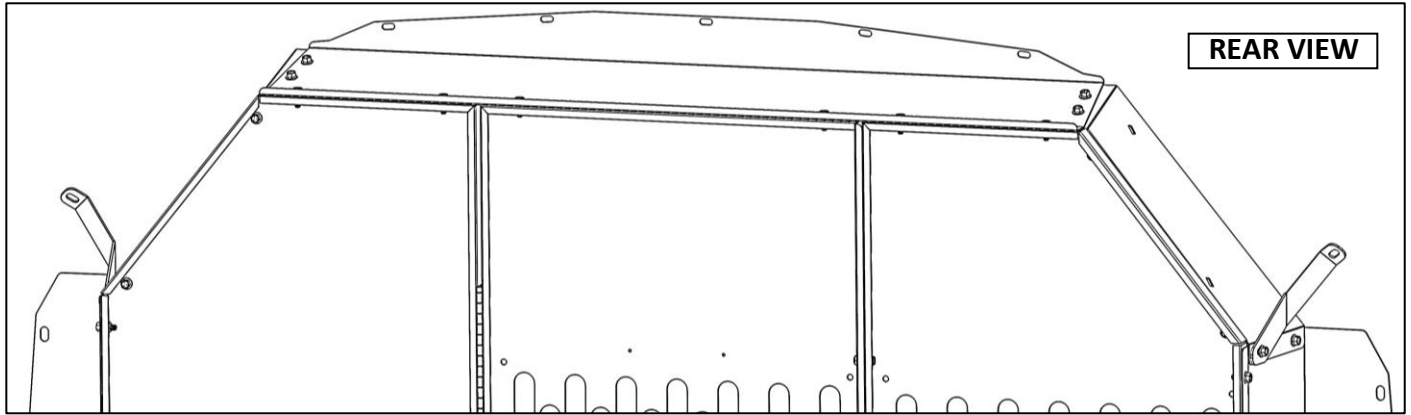

Step 5 – Corner Wing Panels

NOTE: The corner brackets are side specific. Verify the correct bracket position prior to installing.

- Using two 1/4" x 5/8" flanged bolts and two 1/4" flanged locknuts, bolt each corner wing to corner panel.
- Snug tighten but allow for movement.

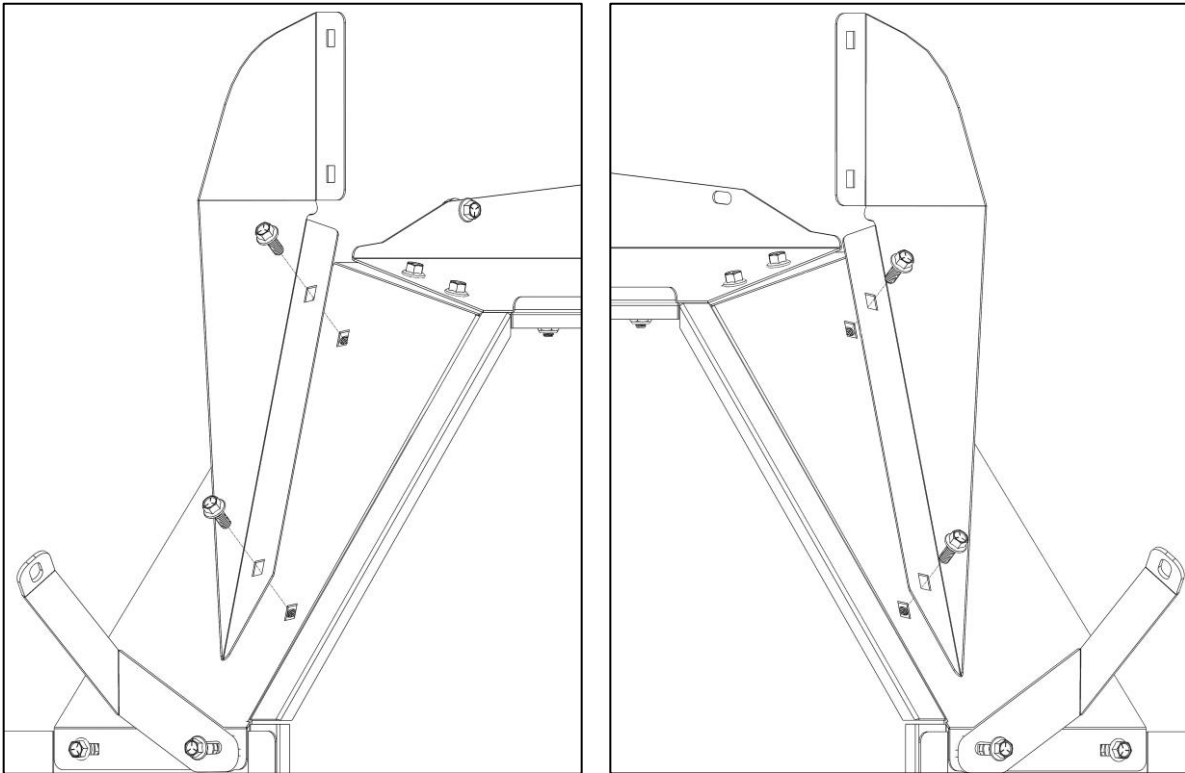

Step 6 – Top Wing

- Using five 1/4" x 5/8" flanged bolts and two 1/4" flanged locknuts, loosely bolt the top wing to the top panel.
- DO NOT tighten.

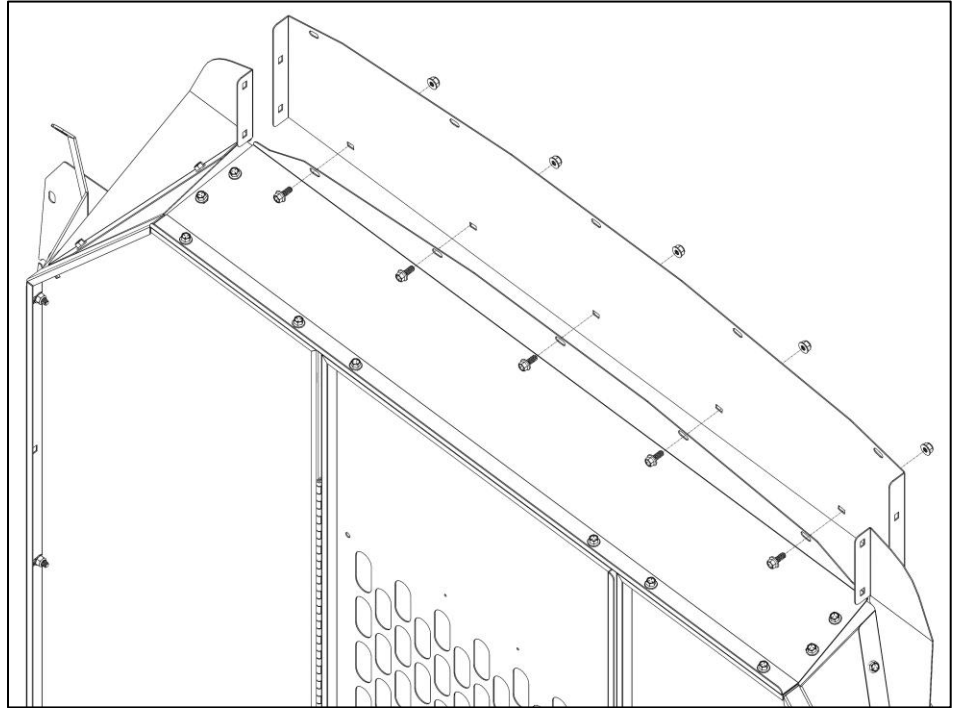

- Using two 1/4" x 5/8" flanged bolts and two 1/4" flanged locknuts, bolt each corner wing to corner panel.

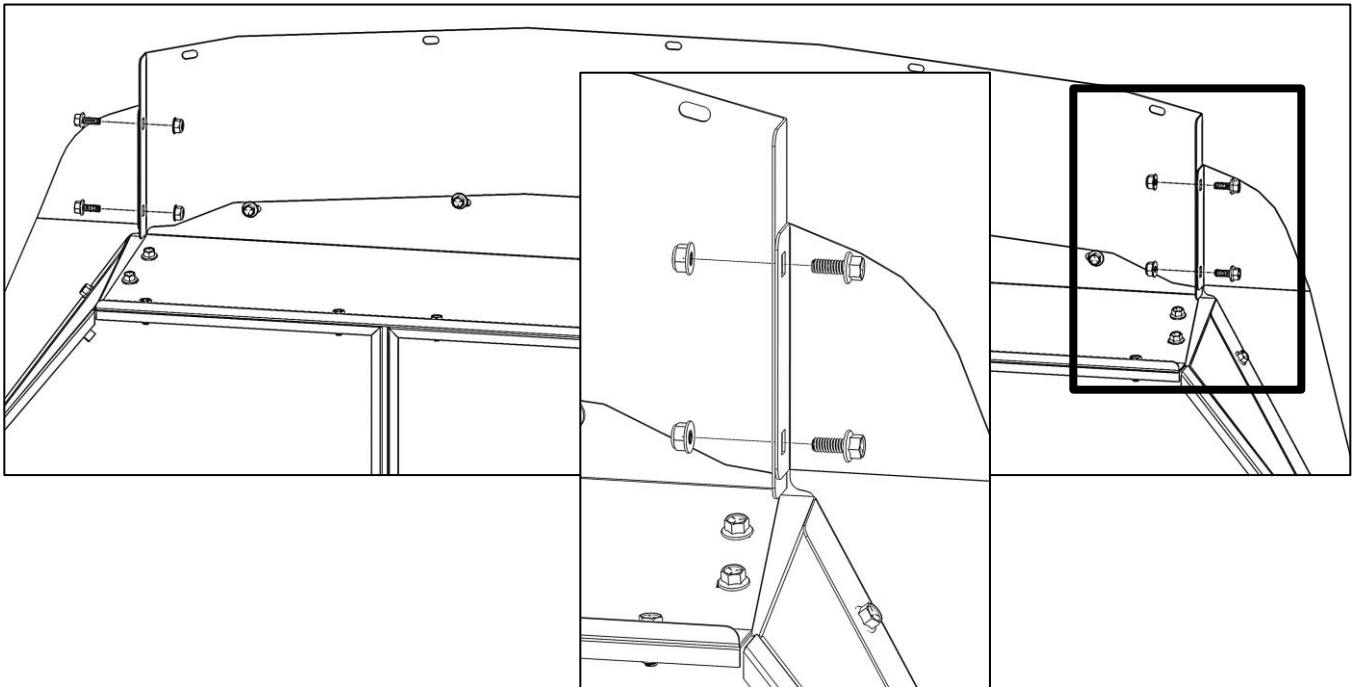

"B" Pillar Installation Notes

- The driver's side wing attaches to "B" pillar in van using self-tapping screws and two M6 clip-on U-nuts.
- The passenger side wing attaches to the "B" pillar using M6 hardware into threaded embosses and self-tapping screws.
- The partition attaches to the floor using 1/4" hardware and plus nuts.
- The corner brackets and top wing attach using self-tapping screws.

Step 7 – Installing Plus Nuts into Floor

- Press the assembled partition with wings firmly against the “B” pillar and the top wing across the roof support of the van.
- Use a straight edge across the floor of the van and tight against the partition panels. Ensure the partition is square and aligned to your liking in relation to the van.
- Choose the best two locations on each outside partition panel to drill and install plus nuts.
- Mark all the slots and holes in the bottom of the partition panels.

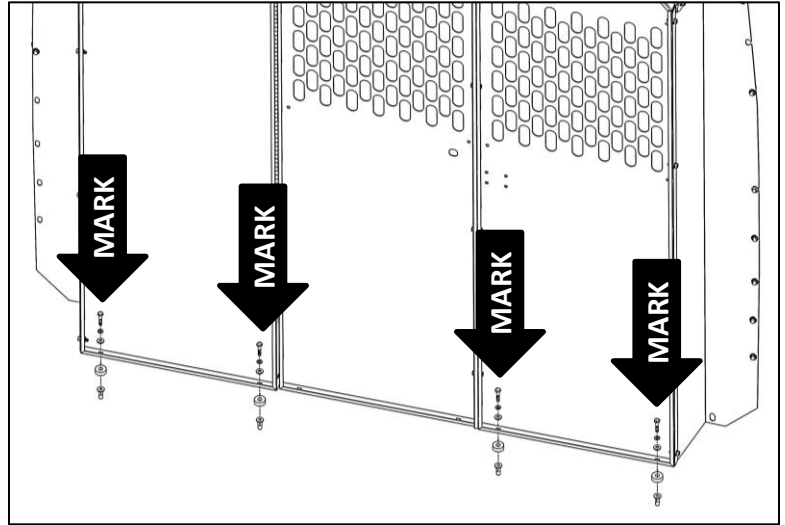

Ensure this is the location of where you want the partition to be installed

- Move partition assembly so the previously marked holes can be accessed.
- Set partition assembly aside.



When installing hardware through any installation surface, always ensure the area behind the installation surface is clear of electrical wiring, fuel tank or lines, or any vehicle safety features.

- At each location marked, drill a hole using a 25/64” bit. A 3/8” drill bit can be used, although it may be necessary to tap in the plus nuts.
- Screw 1/4” x 2-1/4” hex head bolt through 1/4” flat washer and plus nut installation tool, and then into plus nut. Knurled end of plus nut tool must be directed away from bolt head and contacting plus nut.
- Insert plus nut into hole.
- Using the 9/16” box wrench, hold the plus nut tool stationary and then tighten hex head bolt until plus nut is tightly gripping and does not spin when hex bolt is loosened.

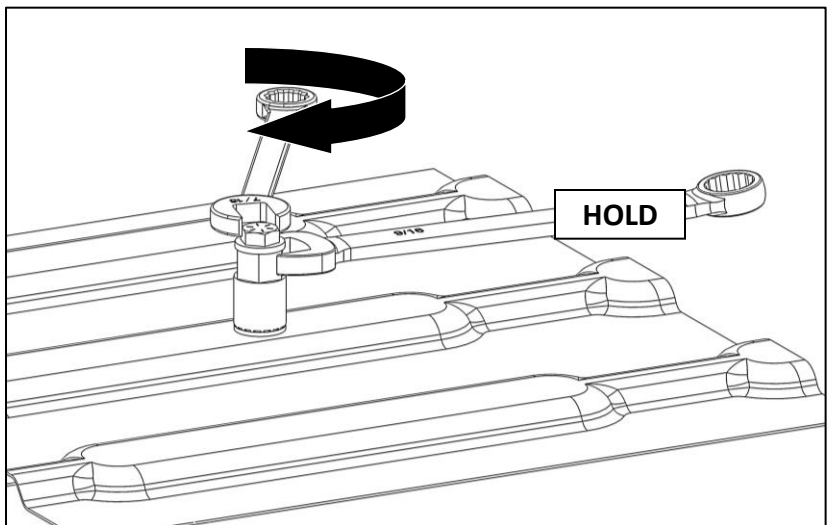
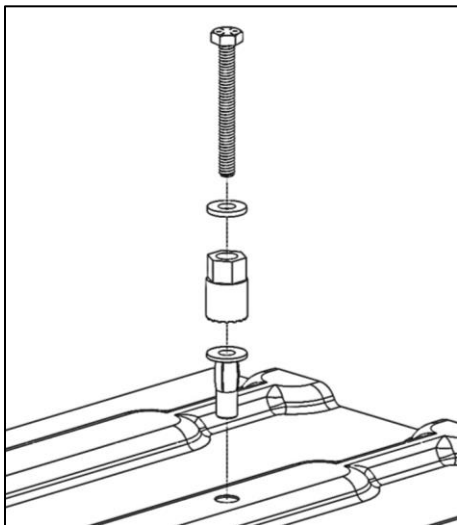

Step 8 – Installing Driver’s Side Wing to “B” Pillar

- On the driver’s side, place one M6 clip-on U-nut in each of the two locations shown.

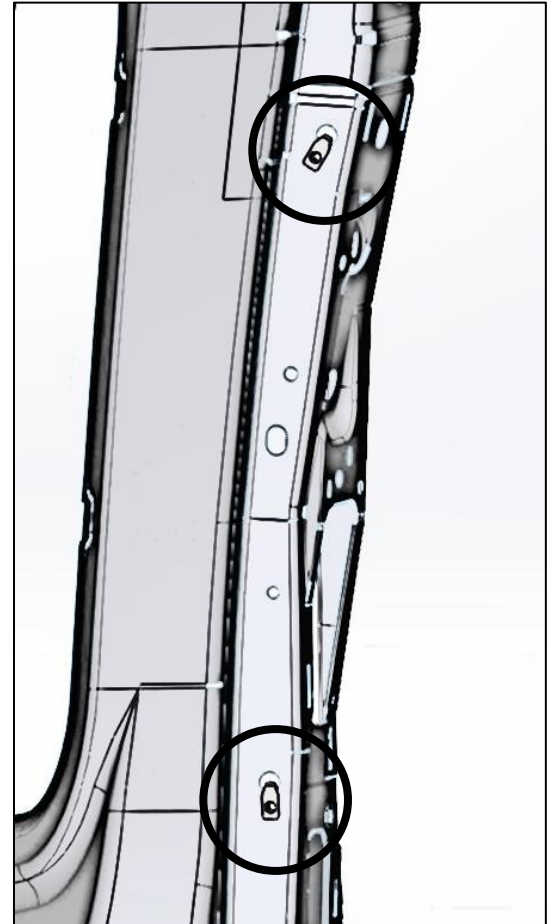
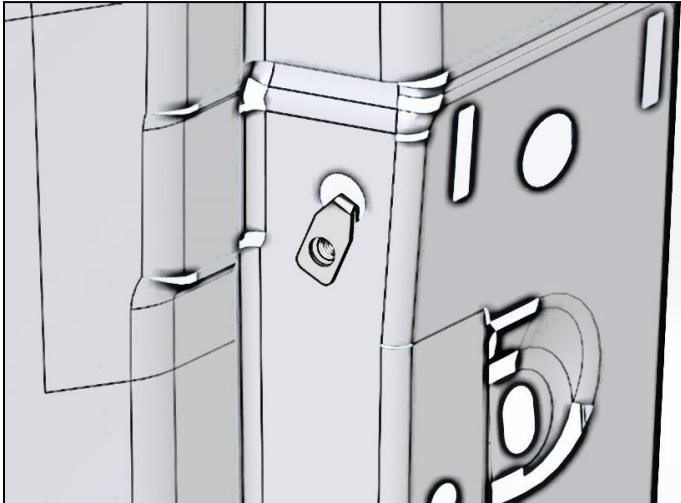

- Place assembled partition into van. Be sure the wing panels are toward the front of the van and the perforated partition side panel in the 40660 is on the passenger side.
- Press the assembled partition with wings firmly against the “B” pillar and the top wing across the roof support of the van.



Always ensure, when installing hardware through any installation surface, the area behind the installation surface is clear of electrical wiring or vehicle safety features.

- Bolt driver’s side wing to the M6 U-Clips using two M6 x 25mm hex head bolts, two 1/4” lock washers and two 1/4” flat washers.
- Snug tighten.

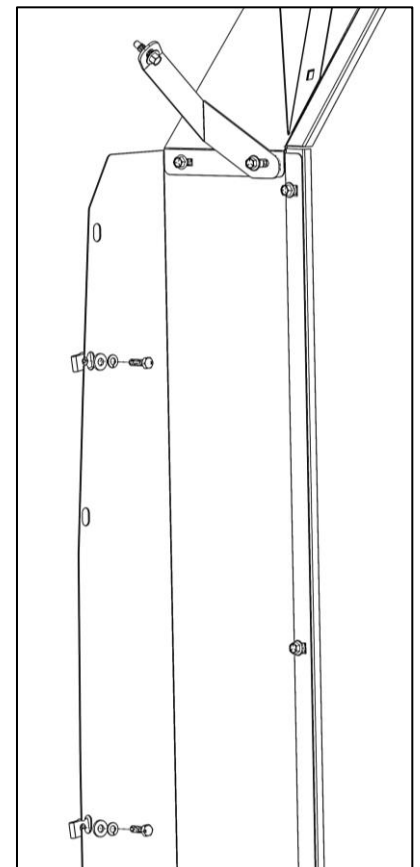
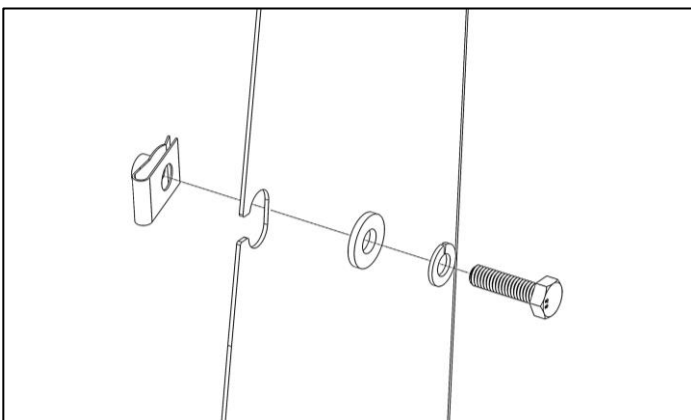

Step 9 – Installing Passenger Wing to “B” Pillar

- Bolt passenger side wing to the threaded embosses in the “B” pillar using M6 x 25mm hex head, 1/4” lock washer and a 1/4” flat washer.
- Repeat for a total of 6 locations as shown.
- Snug tighten.

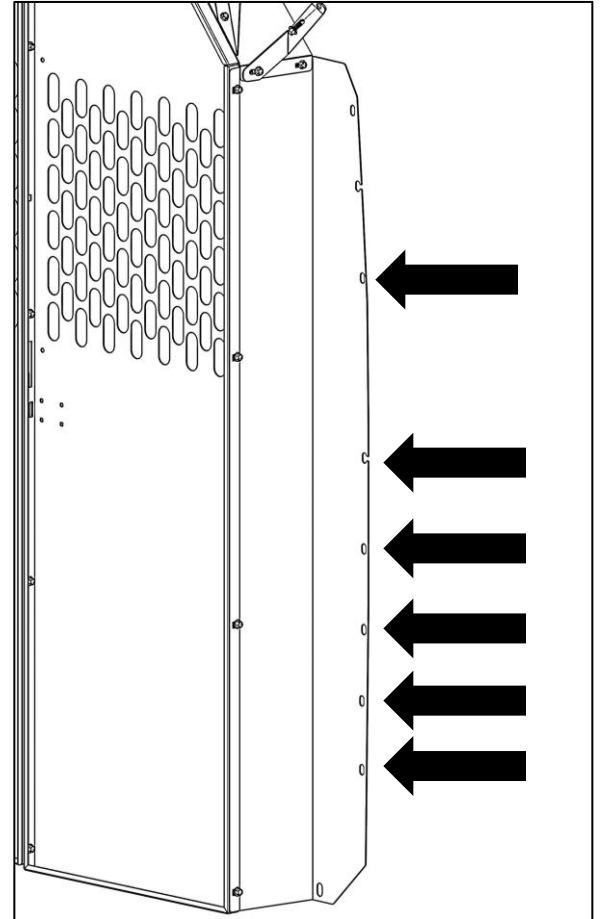
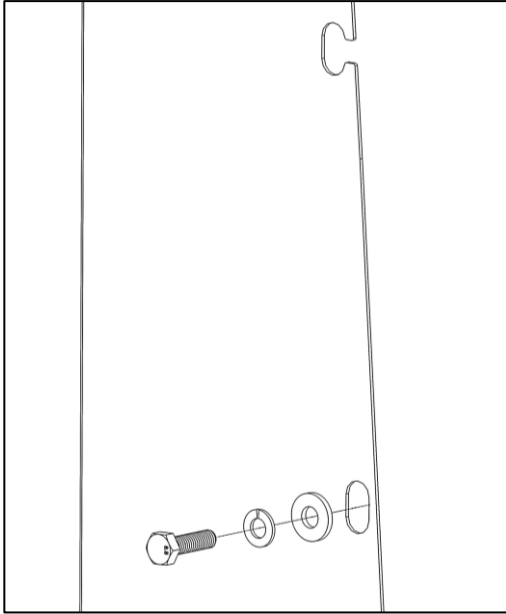

Step 10 – Installing Partition to Floor

- Using 1/4" x 1-1/4" hex head, 1/4" lock washer, and 1/4" flat washer, bolt partition into plus nuts. Place 3/8" nylon washer under partition to bridge gaps between partition and floor, if necessary.
- Snug tighten

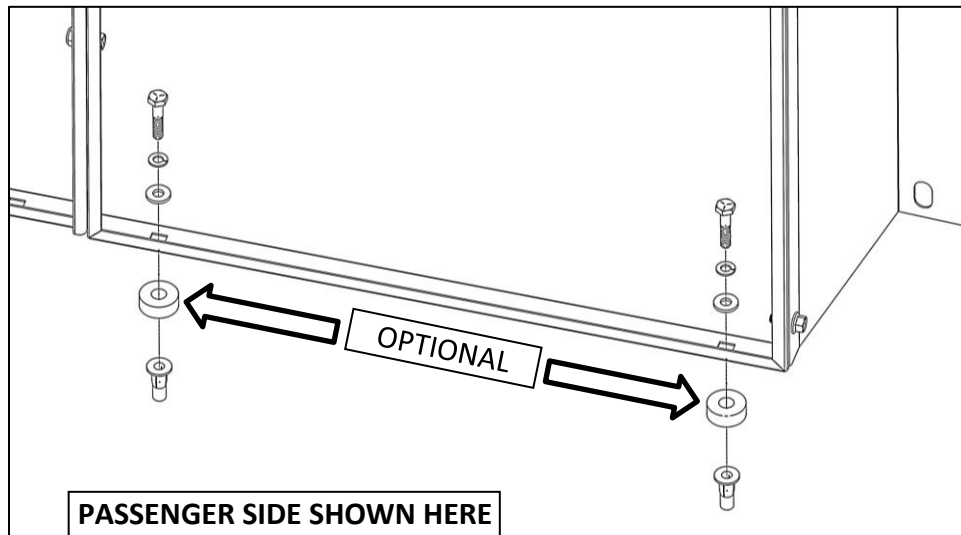

Step 11 – Install Top Wing to “B” Pillar



Always ensure, when installing hardware through any installation surface, the area behind the installation surface is clear of fuel tanks or lines, electrical wiring or vehicle safety features.

- Using 5/16" x 3/4" self-tapping screws, install the top wing to the ceiling roof support.

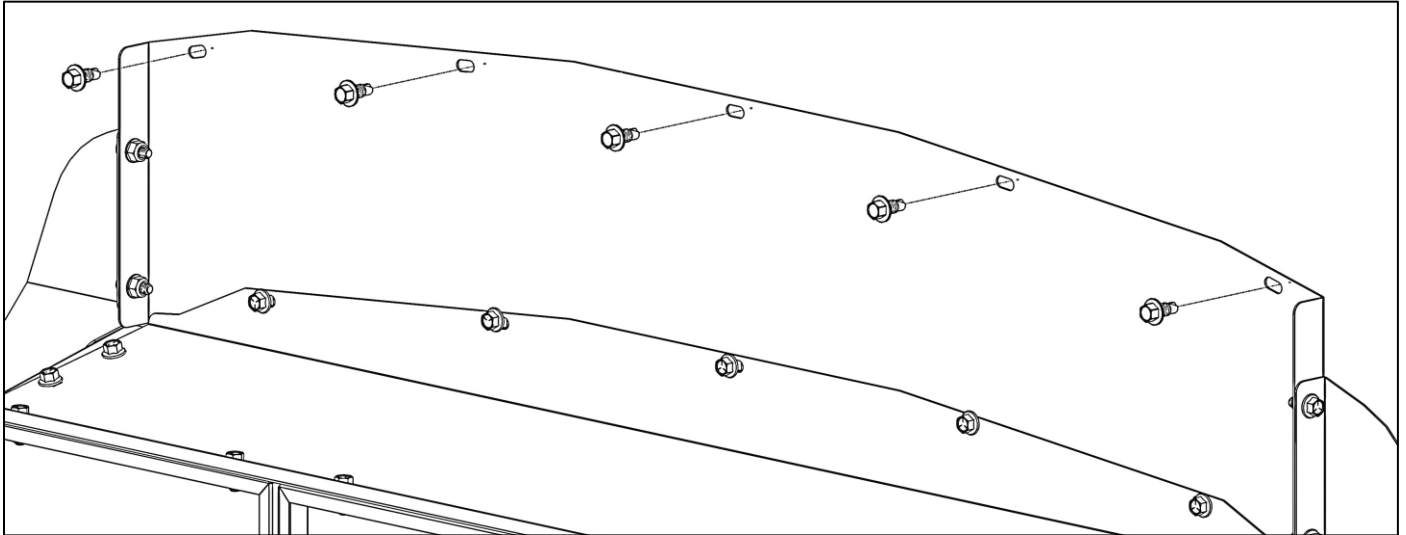

- Using 5/16" x 1" self tapping screws, install the corner bracket to the “B” pillar as shown.
- Repeat on opposite side

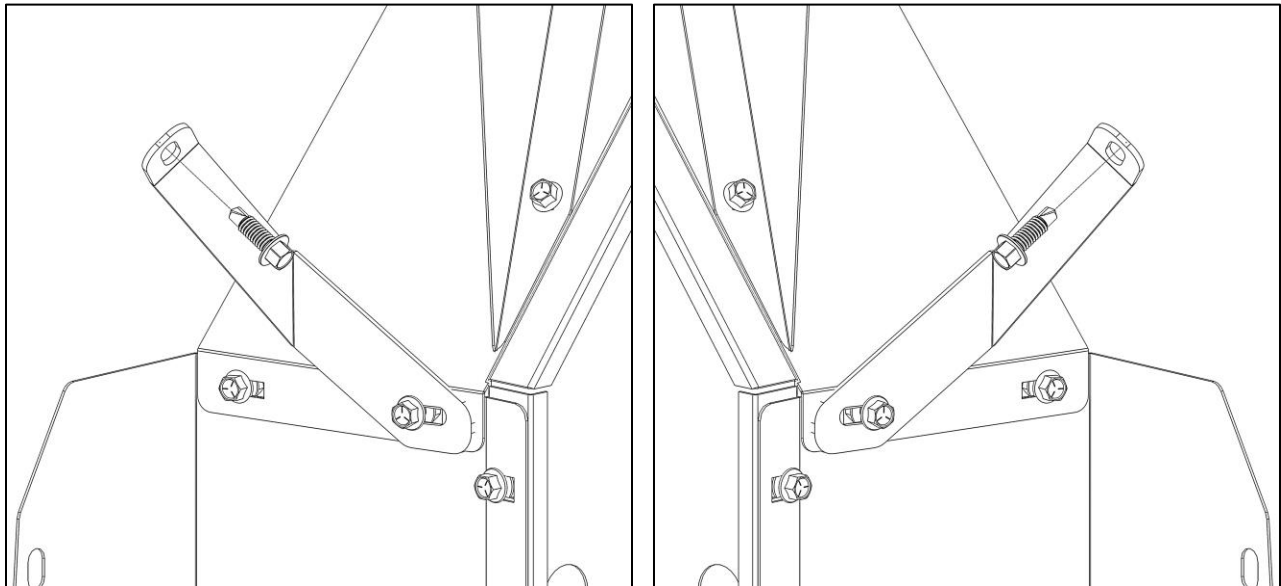

- In the remaining locations along the wings, screw self tap bolts into van.

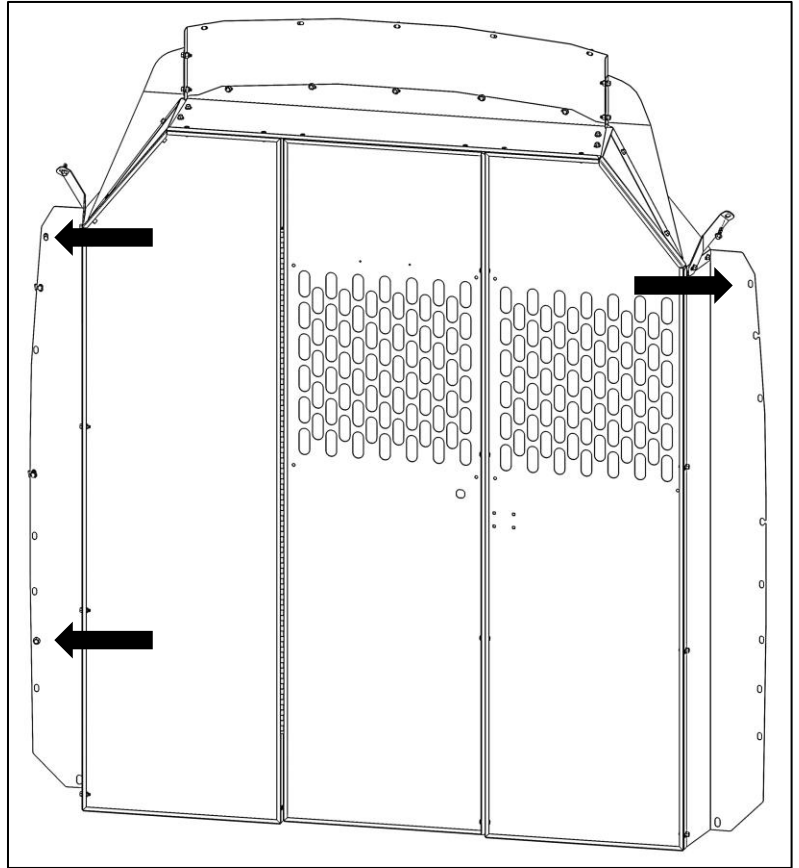

GO BACK AND ENSURE ALL HARDWARE IS TIGHTENED.

ASSEMBLY IS COMPLETE