

KARGO MASTER®

WE PUT EVERYTHING WITHIN REACH.

Instruction Guide

40669SH

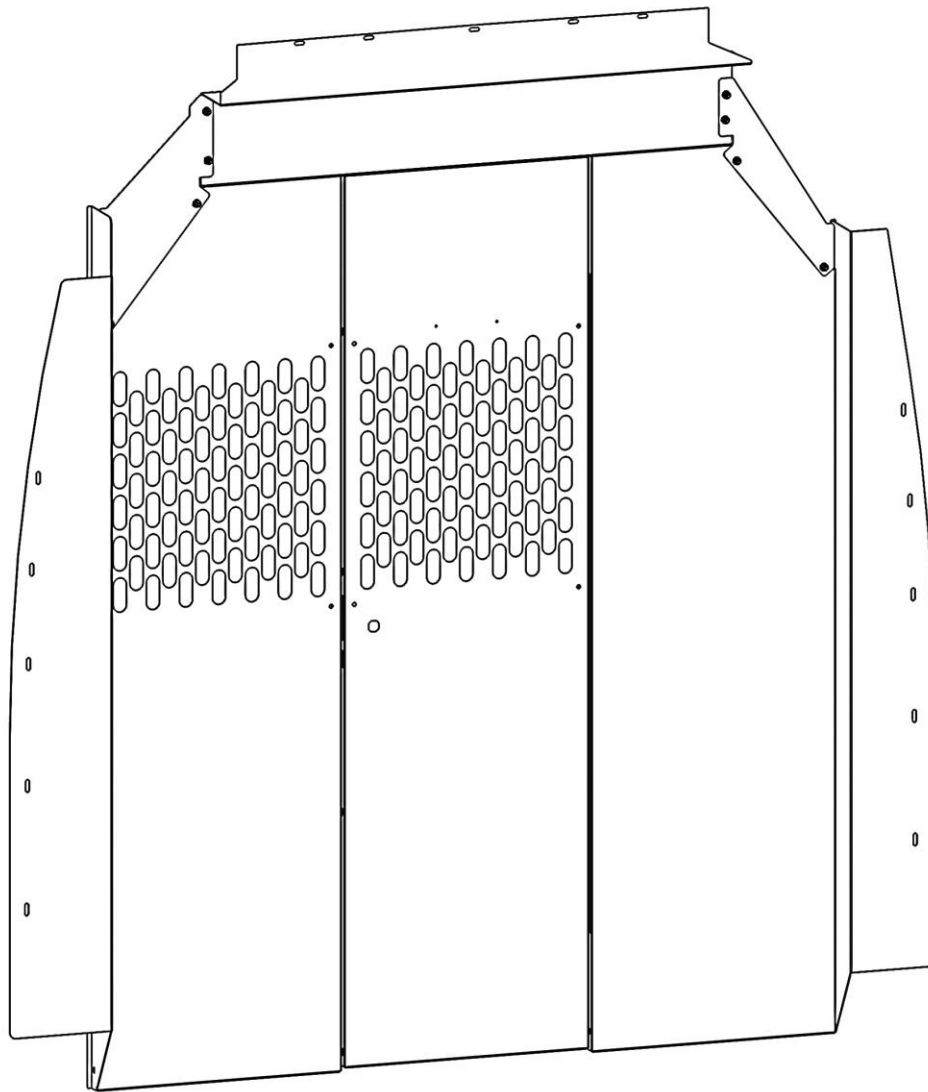

PLEASE READ ALL INSTRUCTIONS AND WARNINGS PRIOR TO ASSEMBLING, INSTALLING, AND USING THIS PRODUCT.

Warning



Always check for wires, fuel tanks and lines, air bags, brake lines, and other important vehicle functionality items prior to drilling and installing all products.

Tools Needed

3/8" Wrench and Socket	7/16" Wrench and Socket
1/2" Wrench and Socket	10mm Wrench and Socket
Drill	25/64" Drill Bit
Drill Bit Stop Collar	Plus Nut Installation Tool (P9902)*

*** Sold Separately.**

Table of Contents

Before You Begin..... 1

Parts List..... 2

Hardware 2

Hardware (Continued) 3

Step 1 – Attach Top Panel 3

Step 2 – Attach Driver Side Corner Panel 4

Step 3 – Attach Passenger Side Corner Panel 4

Step 4 – Attach Side Wings..... 5

Step 5 – Installing Plus Nuts 6

Step 7 – Installing Partition to Roof Cross Brace 7





Step 8 – Installing Partition to Floor 8

Step 9 – Install Partition to B-pillar..... 8



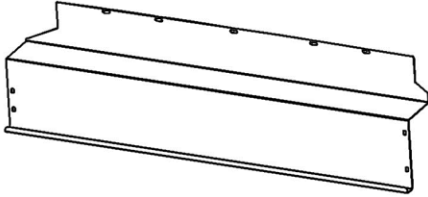

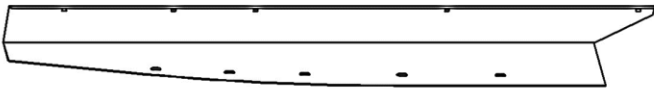
Before You Begin

- READ ALL INSTRUCTIONS prior to installing any Kargo Master product.
- Be sure to have 40660 (Tall Partion) assembled and ready to be installed.
- **Plus Nut Installation Kit (P9902) does not come included and must be purchased separately.**

Parts List

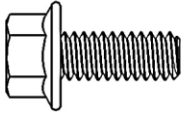
NO.	ITEM	PART NUMBER	DESCRIPTION	QTY.
1		100825	TOP PANEL	1
2		100826	PS SIDE WING	1
3		100827	DR SIDE WING	1
4		100828	PS CORNER PANEL	1
5		100829	DR CORNER PANEL	1
6		18-40669SH	HR SPRINTER HARDWARE KIT	1

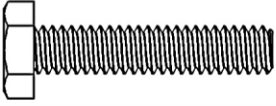
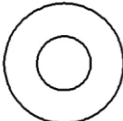
Hardware

ITEM	HARDWARE TO SCALE	PART NUMBER	DESCRIPTION	QTY.
1		11126953	1/4"-20 X 5/8" FLANGED HEX HEAD	24
2		0167030	1/4"-20 FLANGED LOCK NUT	28
3		13800	1/4"-20 X 1-1/4" HEX HEAD BOLT	19
4		33078	1/4" FLAT WASHER	19
5		33618	1/4" LOCK WASHER	19

Hardware (Continued)

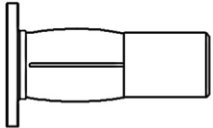
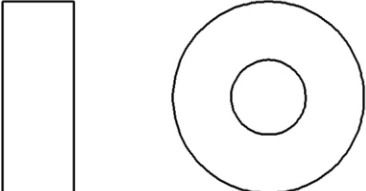
ITEM	HARDWARE TO SCALE	PART NUMBER	DESCRIPTION	QTY.
6		920313726	1/4"-20 PLUS NUT	19
7		11517442	3/8" ID 1" OD NYLON SPACER	4

Step 1 – Attach Top Panel

- Using six 1/4" x 5/8" flanged bolts and 1/4" flanged locknuts, bolt top panel to partition (40660).
- Snug tighten but allow for movement.

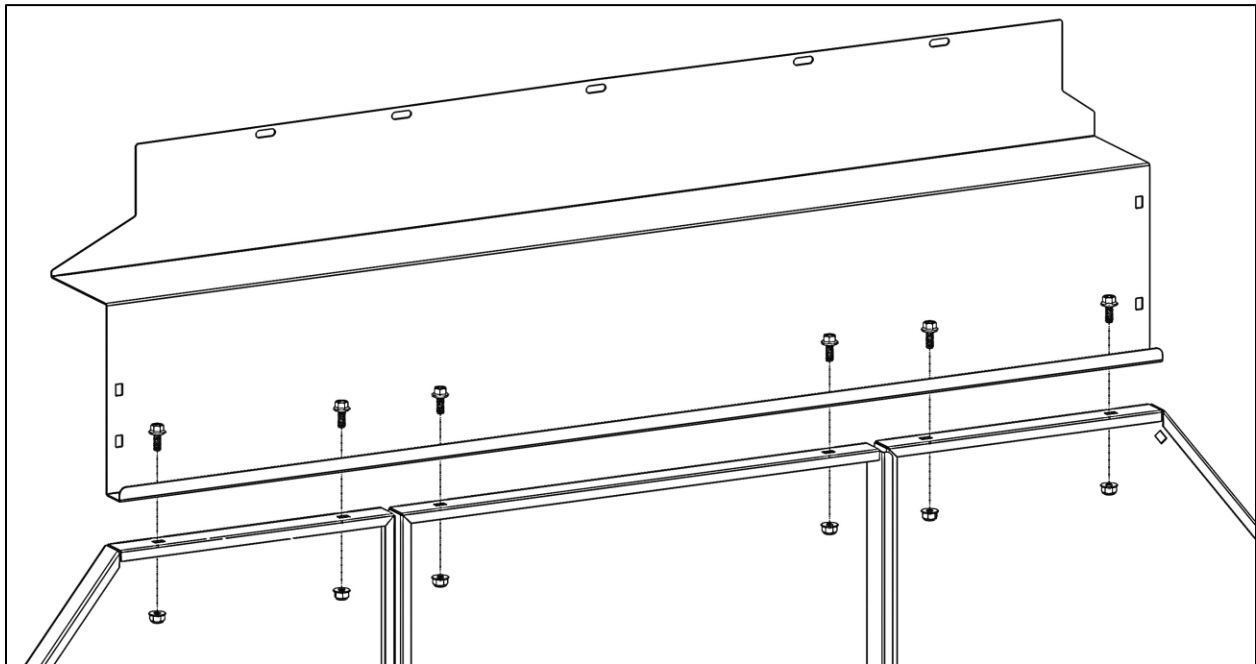

Step 2 – Attach Driver Side Corner Panel

NOTE: The corner brackets are side specific. Verify the correct bracket position prior to installing.

- Using four 1/4" x 5/8" flanged bolts and 1/4" flanged lock nuts, bolt DS corner panel to partition and top panel.
- Snug tighten but allow for movement.

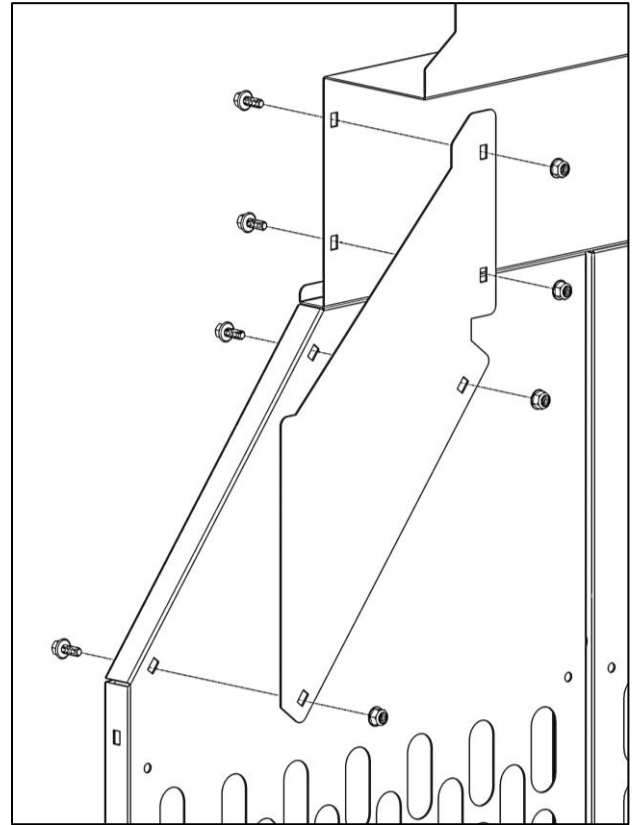

Step 3 – Attach Passenger Side Corner Panel

- Using four 1/4" x 5/8" flanged bolts and 1/4" flanged lock nuts, bolt PS corner panel to partition and top panel.
- Snug tighten but allow for movement.

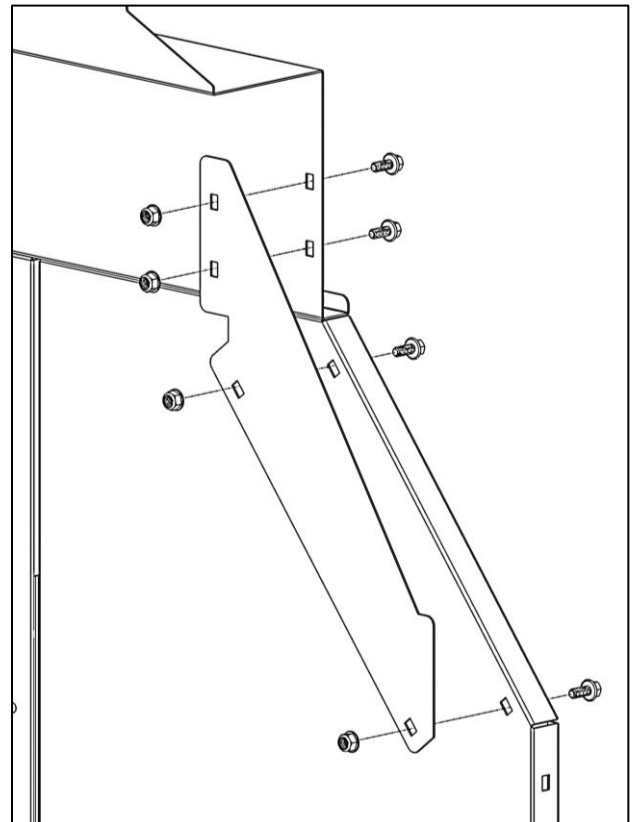

Step 4 – Attach Side Wings

- Using five 1/4" x 5/8" flanged bolts and 1/4" flanged lock nuts, bolt **PS** side wing to partition.
- Snug tighten but allow movement.
- Using five 1/4" x 5/8" flanged bolts and 1/4" flanged lock nuts, bolt **DS** side wing to partition.
- Snug tighten but allow movement.

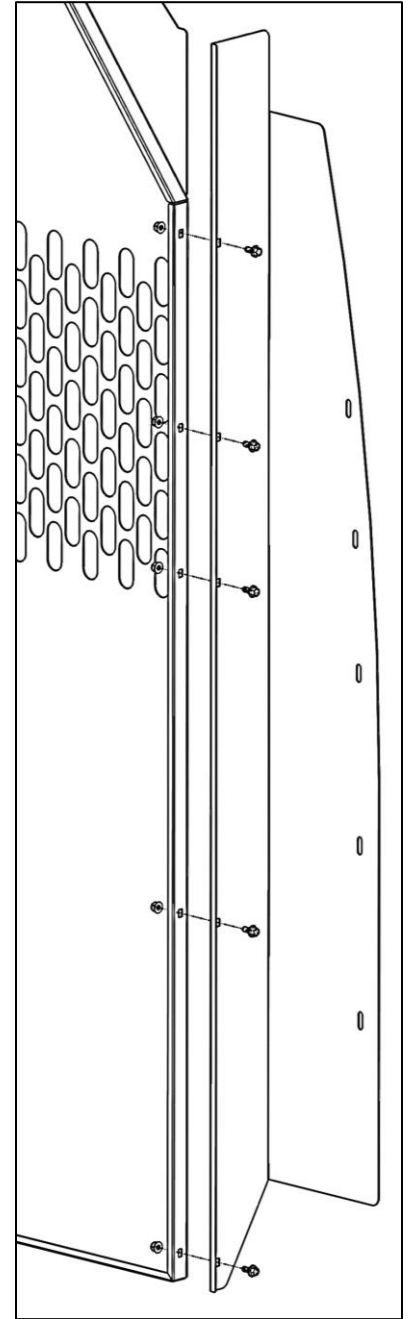
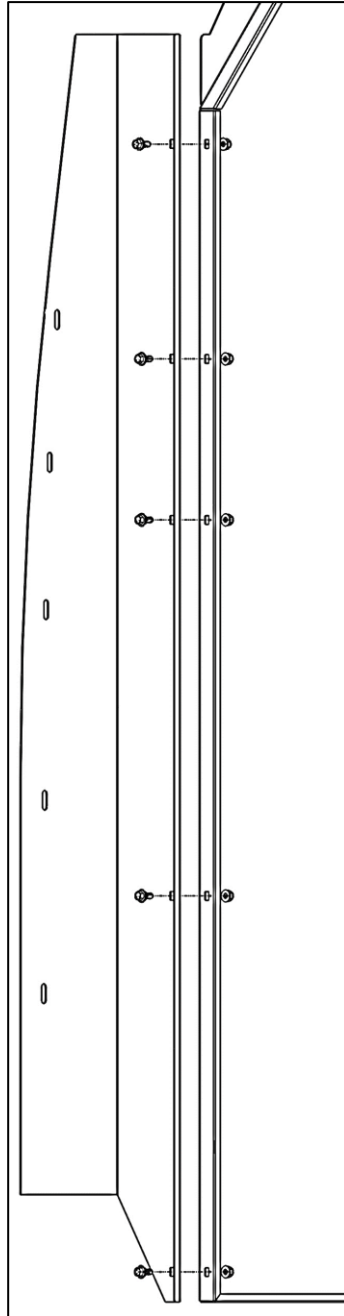

Step 5 – Installing Plus Nuts

NOTE: Additional lock nuts have been provided for alternate installation of the bolts through the floor.

- Press the assembled partition so that wings are firmly against each B-pillar and so that the top wing is squarely against and across the roof support of the van.
- Use a straight edge across the floor of the van and tight against the partition panels to ensure the partition is square and aligned to your liking, relative to the van.

Be sure this is the location of where you want the partition to be installed.

- Mark onto the floor all the slots and holes in the bottom of the partition panels. Choose the best two locations on the bottom of each outside partition panel to drill and install plus nuts.

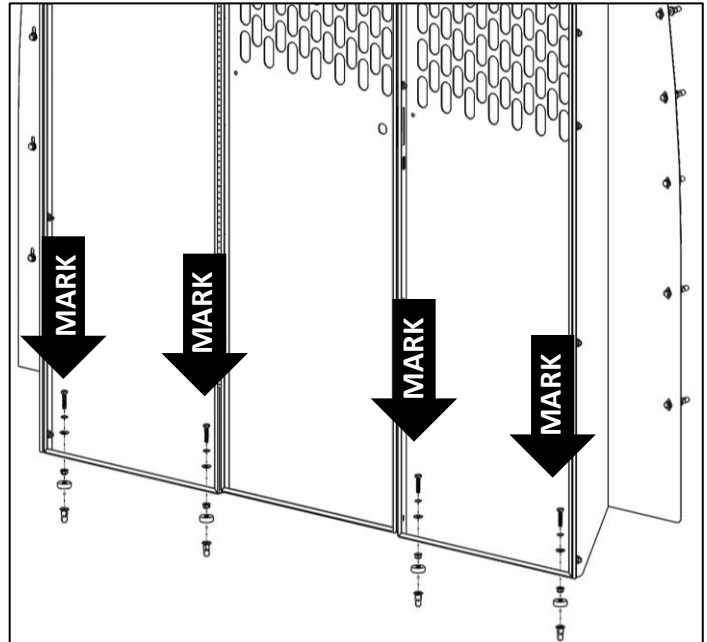

- Mark onto roof brace locations of all slots in top wing.
- Mark onto both B-pillars locations of all slots in side wings.
- Move partition assembly so the previously marked holes can be accessed.



When installing hardware through any installation surface, always ensure the area behind the installation surface is clear of electrical wiring, fuel tank or lines, or any vehicle safety features.

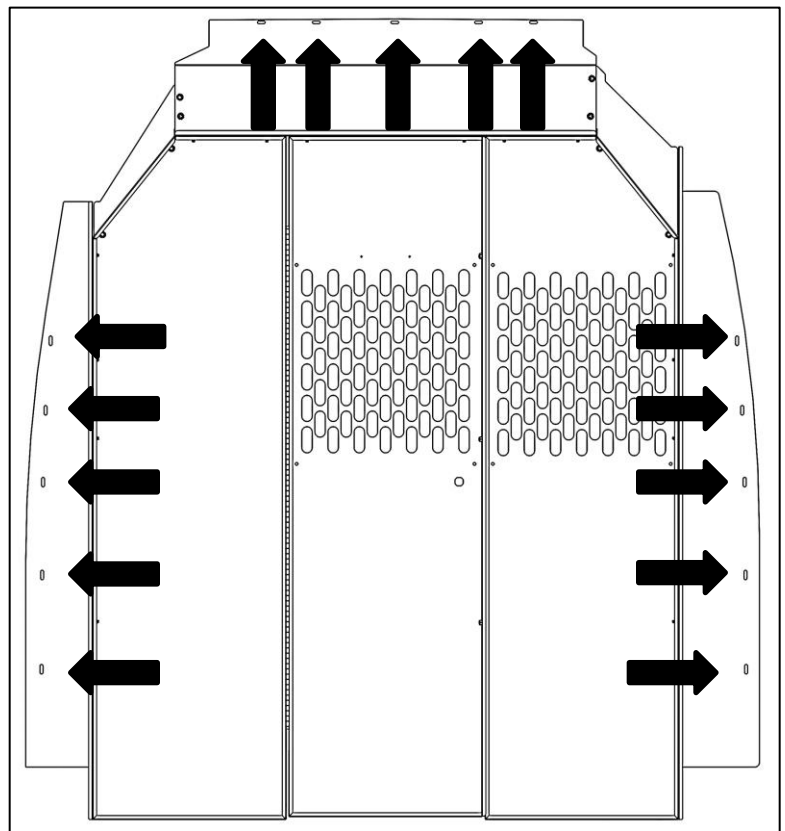

- At each location marked, drill a hole using a 25/64" bit. A 3/8" drill bit can be used, although it may be necessary to tap in the plus nuts.
- Screw 1/4" x 2-1/4" hex head bolt through 1/4" flat washer and plus nut installation tool, and then into plus nut. Knurled end of plus nut tool must be directed away from bolt head and contacting plus nut.
- Insert plus nut into hole.
- Using the 9/16" box wrench, hold the plus nut tool stationary and then tighten hex head bolt until plus nut is tightly gripping and does not spin when hex bolt is loosened.

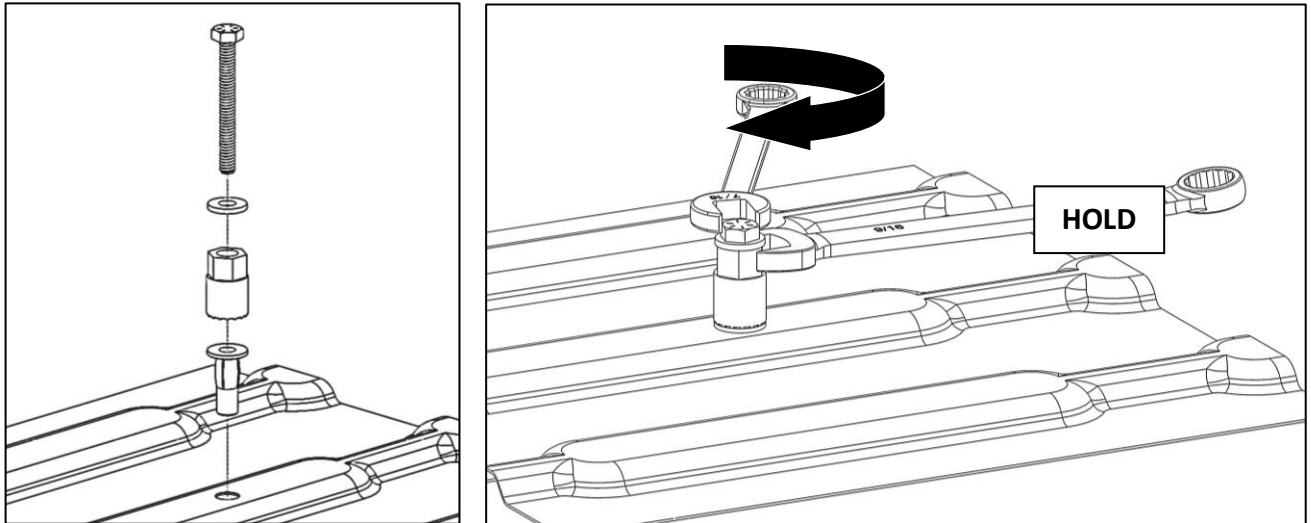

Step 6 – Installing Partition to Roof Cross Brace

- Place partition with wings back into van, in position, with holes aligned with installed plus nuts.
- Bolt top of partition to roof cross brace using five 1/4" x 1-1/4" hex head bolts, 1/4" lock washers and 1/4" flat washers.
- Snug tighten but allow for movement.

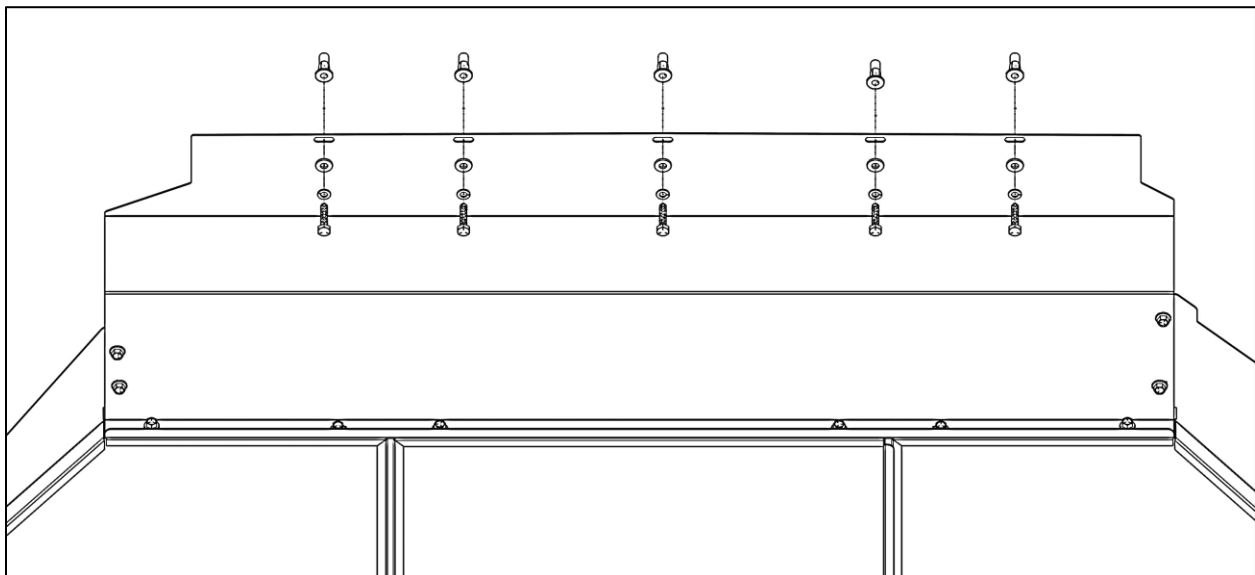

Step 7 – Installing Partition to Floor

- Using four 1/4" x 1-1/4" hex head bolts, 1/4" lock washers, 1/4" flat washers, and 3/8" nylon spacers, bolt partition to installed plus nuts. **Spacers are optional, but be sure to place under partition and bolt through 3/8" nylon spacer to bridge gaps between partition and floor, as necessary.**
- Snug tighten but allow movement.

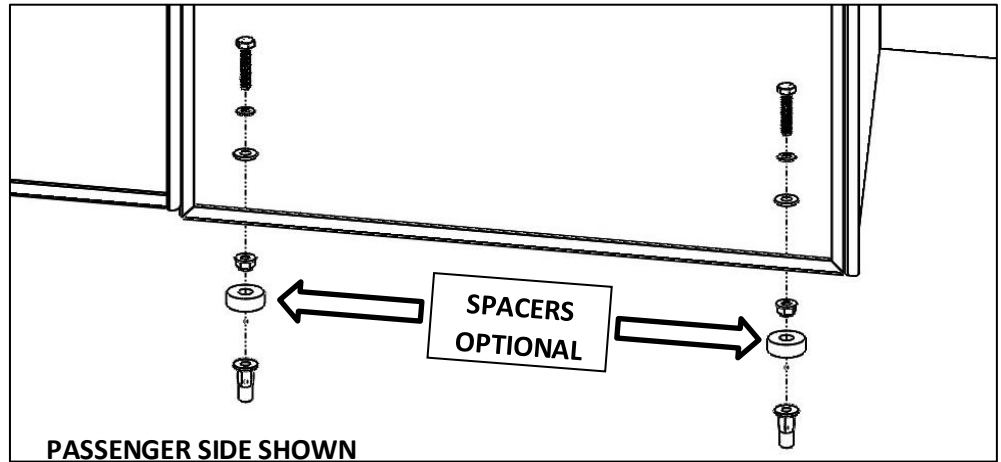

Step 8 – Install Partition to B-pillar

- Using 1/4" x 1-1/4" hex head bolts, 1/4" lock washers and 1/4" flat washers, bolt partition with wings to plus nuts installed in B-pillars.

**GO BACK AND ENSURE ALL
HARDWARE IS
TIGHTENED.**

**ASSEMBLY AND
INSTALLATION ARE
COMPLETE.**

