

KARGO MASTER[®]

WE PUT EVERYTHING WITHIN REACH.

Installation Guide

4064P

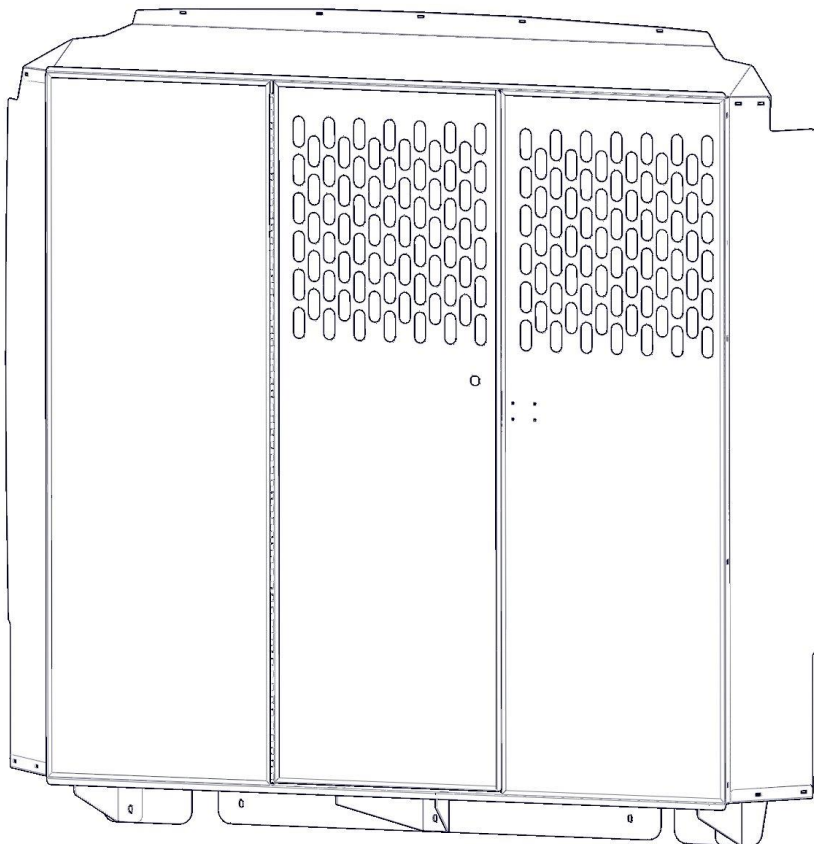

***PLEASE READ ALL INSTRUCTIONS AND WARNINGS PRIOR TO ASSEMBLING,
INSTALLING, AND USING THIS PRODUCT***

Warning



Always check for wires, fuel tanks and lines, brake lines and other important vehicle functionality items prior to drilling and installing all products.

Tools Needed

3/8" Wrench and Socket	7/16" Wrench and Socket
25/64" Drill Bit	

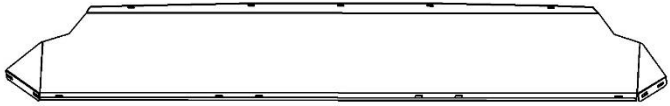
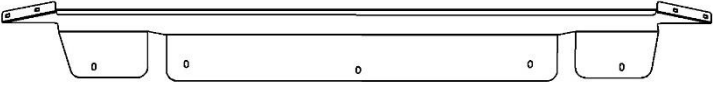



Table of Contents

Parts List	2
Hardware List	3
Step 1 Install Top Wing	4
Step 2 Install Floor Mount	5
Step 3 Install floor supports	6
Step 4 Install Wings	7
Step 5 Install Partition	8

Before You Begin

- Read all instructions.
 - Have tall partition (40651 or 40652) assembled.
 - ENSURE SAFETY BEFORE DRILLING OR CUTTING
-

Parts

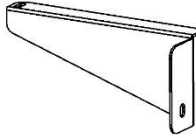
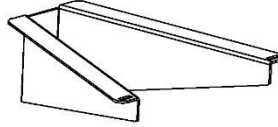
ITEM NO.		PART NUMBER	DESCRIPTION	QTY.
A		4064P-00-001	ProMaster Top Panel	1
B		4064P-00-002	ProMaster Partition Bottom Panel	1
C		4064P-00-003	Promaster Partition Driver Wing	1
D		4064P-00-004	ProMaster Partition Passenger Wing	1
E		4064P-00-005	Outside Support - PS	1
F		Mirror4064P-00-005	Outside Support - DS	1
G		4064P-00-006	Middle Support	1

Hardware

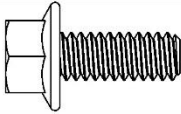
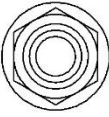
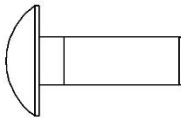
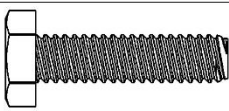
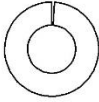
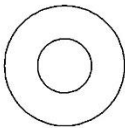
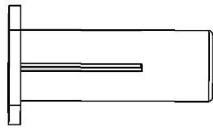
ITEM NO.	TO SCALE	DESCRIPTION	PART NUMBER	QTY.
1		.25-20 x .625 Flange HH	92979A114	26
2		.25-20 Flanged Nyloc Nut	93298A110	28
3		.25 X .75 CARRIAGE BOLT	.25 X .75 CARRIAGE BOLT	2
4		.25-20x1.0 Hex Bolt	.25-20x1.0 Hex Bolt	8
5		.25 Lock Washer	.25 Lock Washer	8
6		.25 Flat Washer	90126A029	8
7		.25-20 Plus Nut	.25-20 Plus Nut	8

Assemble Partition (40651)

Step 1 – Install Top Wing

- Use top wing (A) as a template. Hold top wing inside of van, above the seats and against the headliner.
- Mark on the headliner through the slots of the top wing.
- Before cutting headliner, bend the headliner out of the way to be sure the marking is lined up with the holes in the support beam.
- Cut headliner to expose holes in support beam.
- Use 25/64" drill to open up exposed holes.
- Install plusnuts (7).
- Bolt top wing (A) to the 5 plus nuts (7) previously installed using 1/4" x 1" hex head bolts (4), 1/4" lock washers (5) and 1/4" flat washers (6).
- Snug Tighten, but allow movement

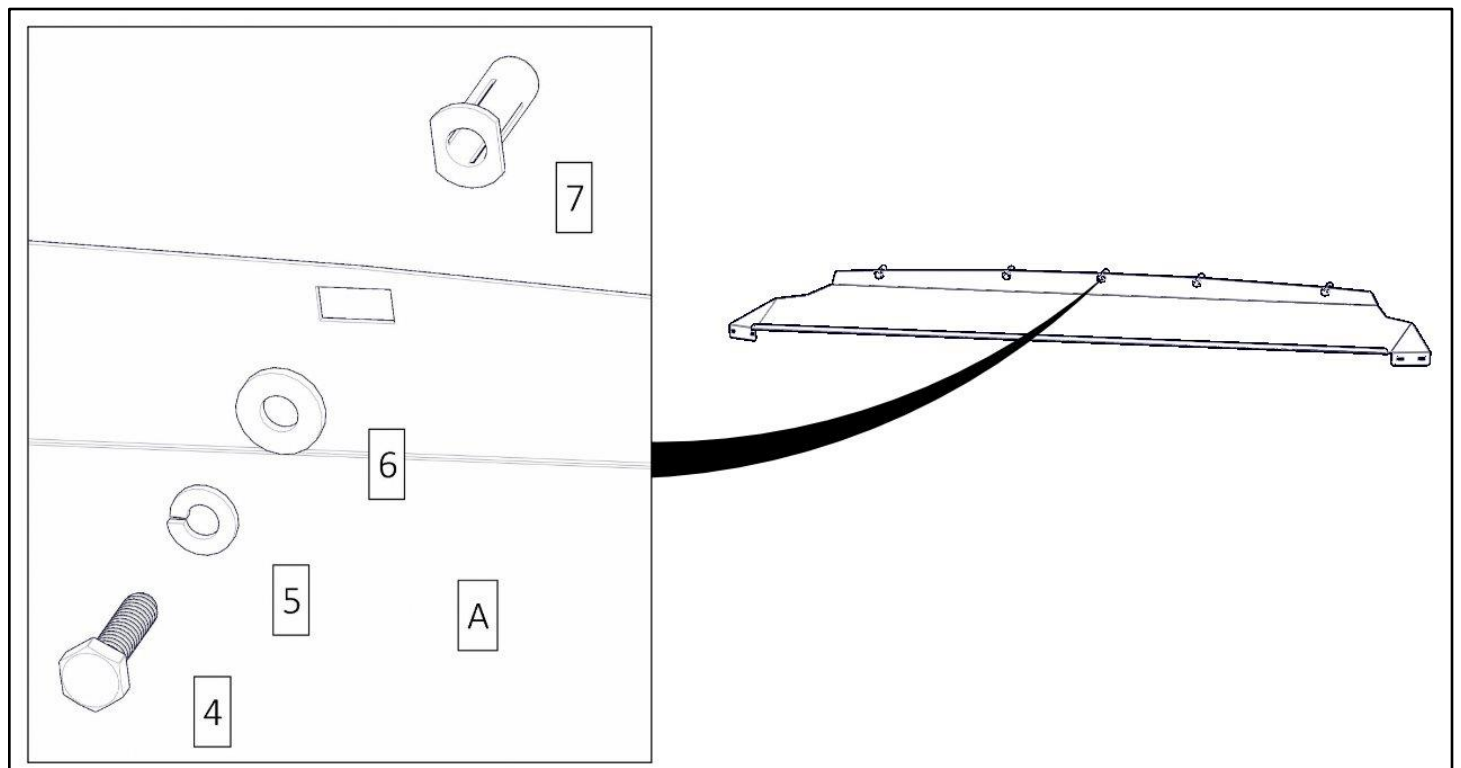
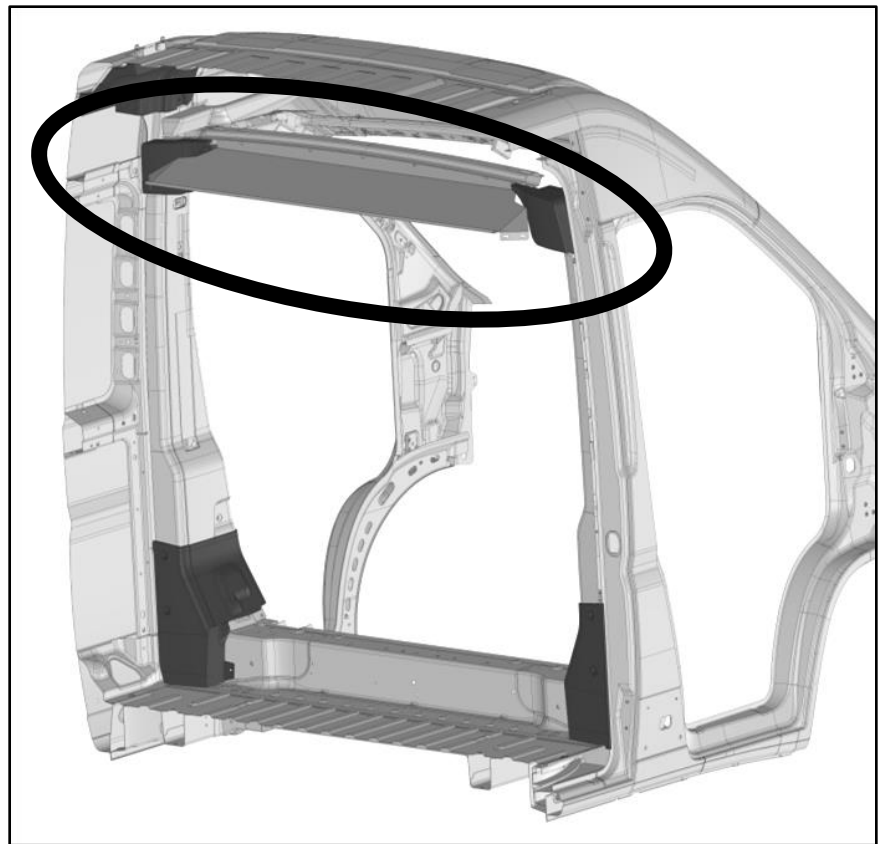

Step 2 – Install Floor Mount

- Remove D-Rings below seats.
- Use bottom wing (B) as a template. Hold bottom wing inside of van below the seats.
- Align the outside holes on the bottom wing with the previously removed D-Ring holes. Press against pedestal.
- Mark through the 3 middle slots of the bottom wing onto the van.
- Remove bottom wing.
- Use 25/64" drill to drill marked locations.
- Install three plusnuts in previously drilled holes.

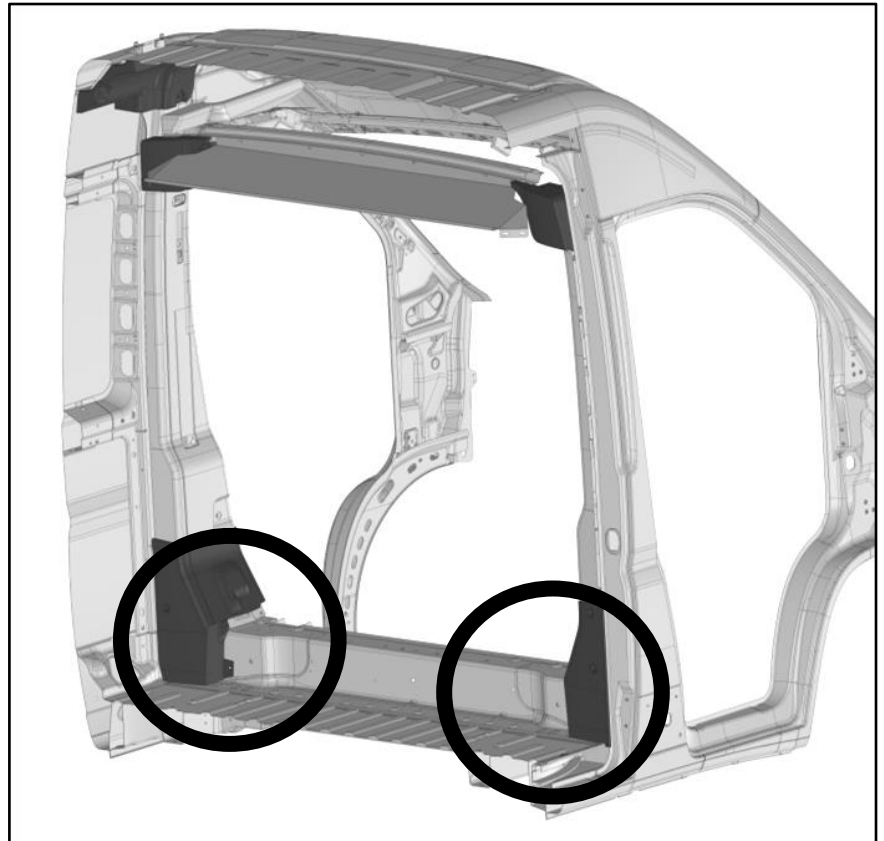

- Bolt bottom wing (B) to the 2 outside plus nuts (7) previously installed using 1/4" x 1" hex head bolts (4), 1/4" lock washers (5) and 1/4" flat washers (6).

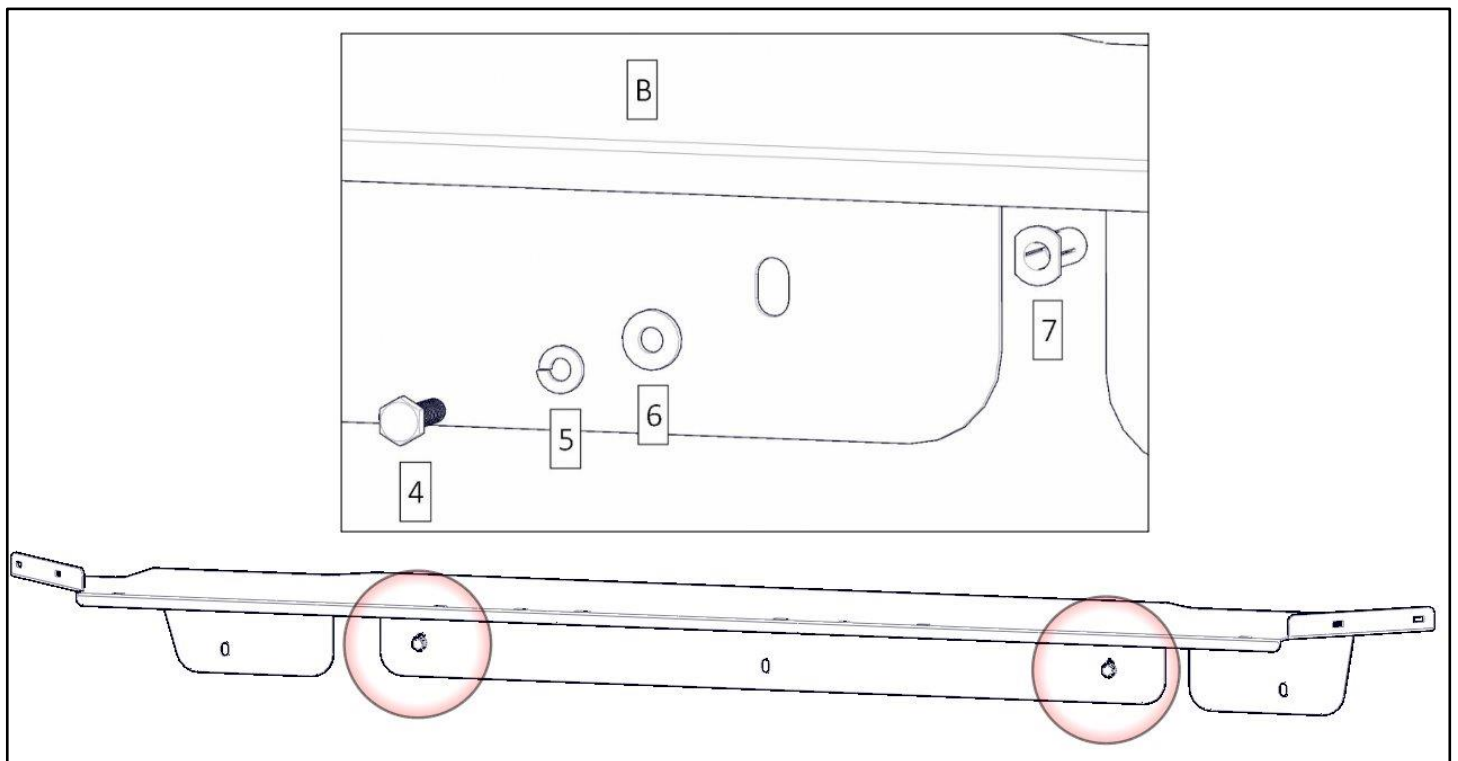

- Snug Tighten, but allow movement

Step 3 – Install Floor Supports

- Place bottom supports (E, F & G) under bottom wing (B).
- Align outside supports (E & F) with previously removed D-Rings. Bolt using ONLY the previously removed D-Rings.

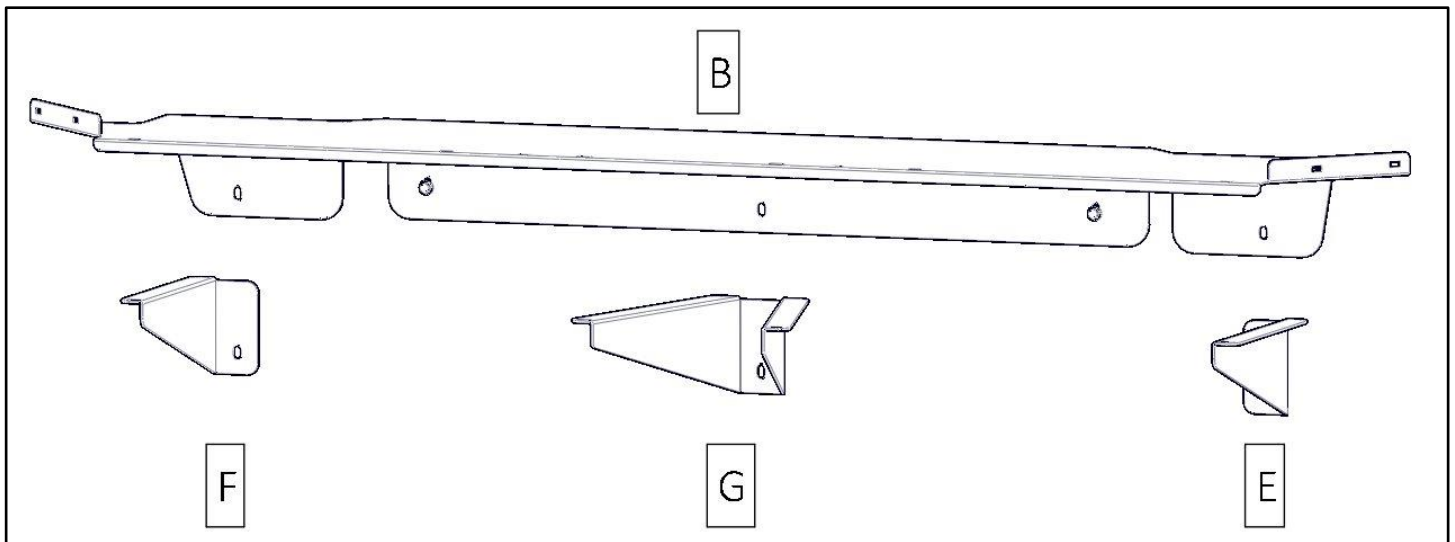

- Bolt through the center slot of the bottom wing (B) and the middle support (G) into the center plus nut that was previously installed using 1/4" x 1" hex head bolts (4), 1/4" lock washers (5) and 1/4" flat washers (6).
- Bolt middle support to bottom wing out on the edge of platform using two 1/4" x 3/4" carriage bolts (3) and two 1/4" flanged nylocs (2).

At this time, only attach the middle support to the bottom wing

- Snug Tighten, but allow movement

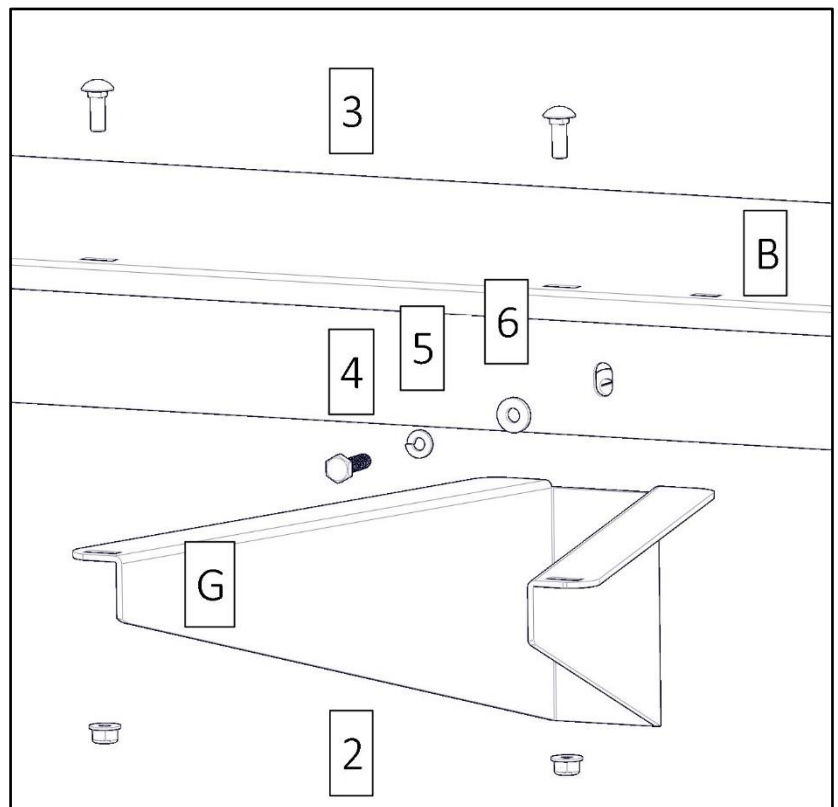

Step 4 – Install Wings

- Attach side wings (C & D) to both top and bottom wings (A & B) using two flanged hex head bolts (1) and two flanged nyloc nuts (2) in each corner.
- Snug Tighten, but allow movement

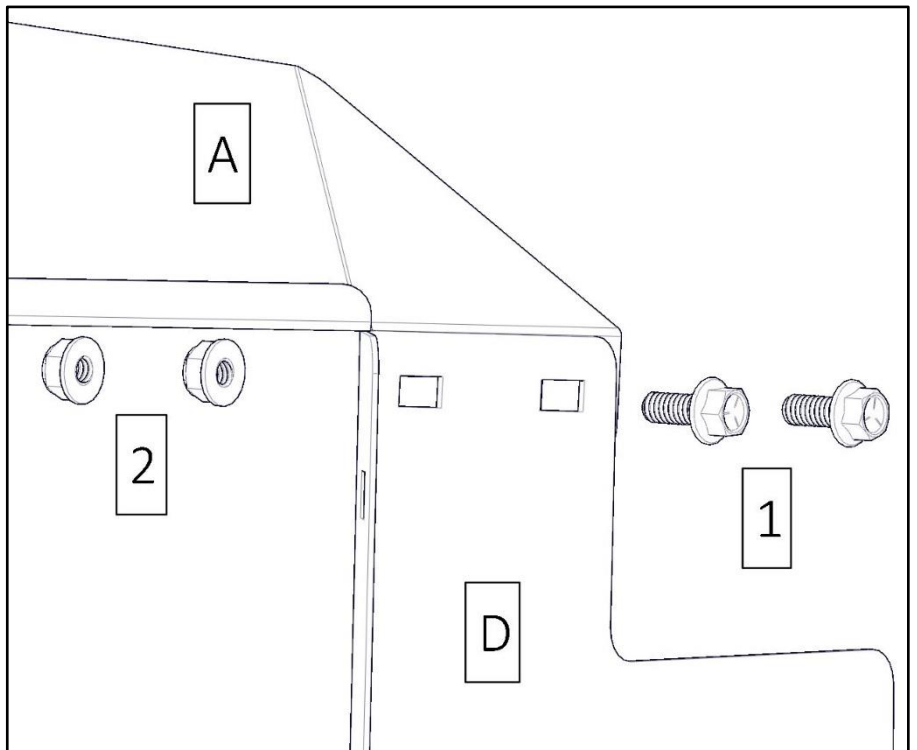
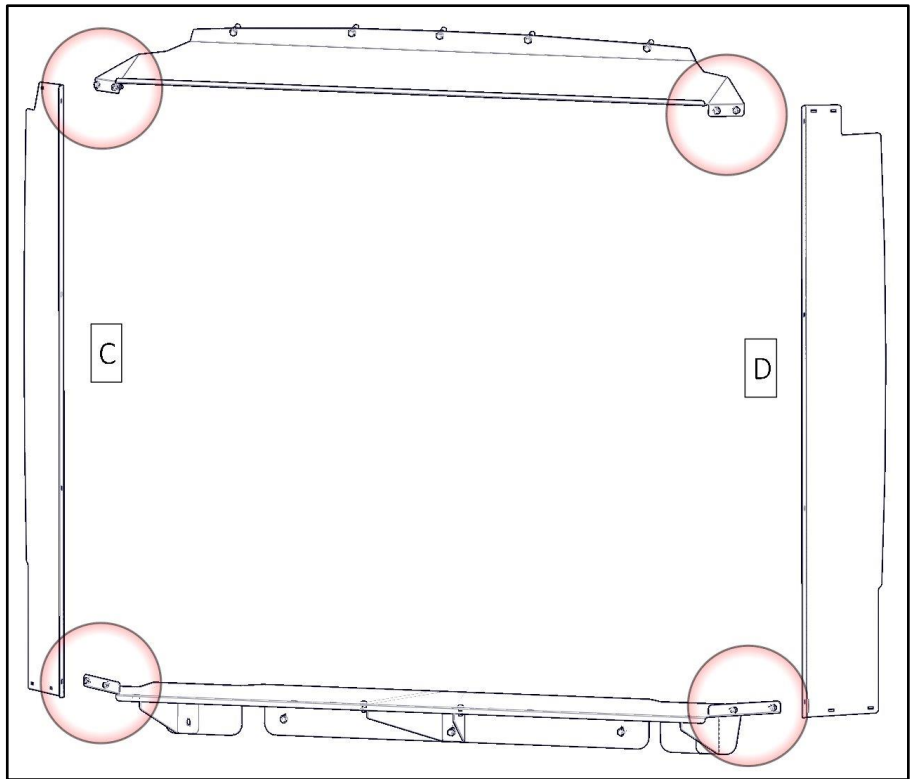

Step 5 – Install Partition

- Insert partition (40651 or 40652) assembly into van. Be sure to have the flanges to the rear of the van.
- Bolt all around edges of partition to top and side panels using 1/4" flanged hex head bolts and 1/4" flanged nyloc nuts.
- Along the bottom of the partition, be sure to bolt through the supports installed in step 3.
- If using the pass through door, DO NOT bolt through middle panel of the partition.
- Snug Tighten, but allow movement.

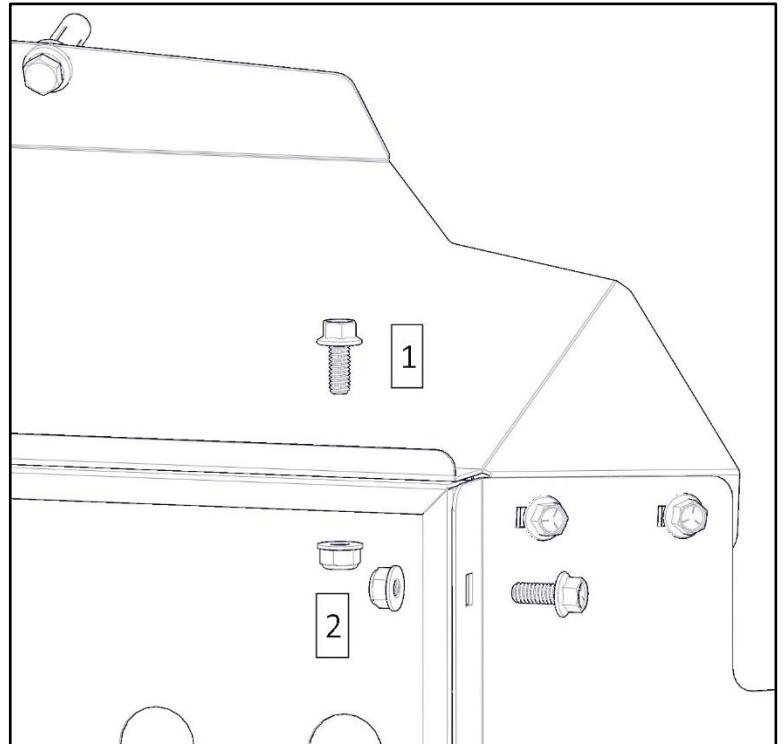

Square and align partition to your liking.
Tighten all bolts from previous steps.

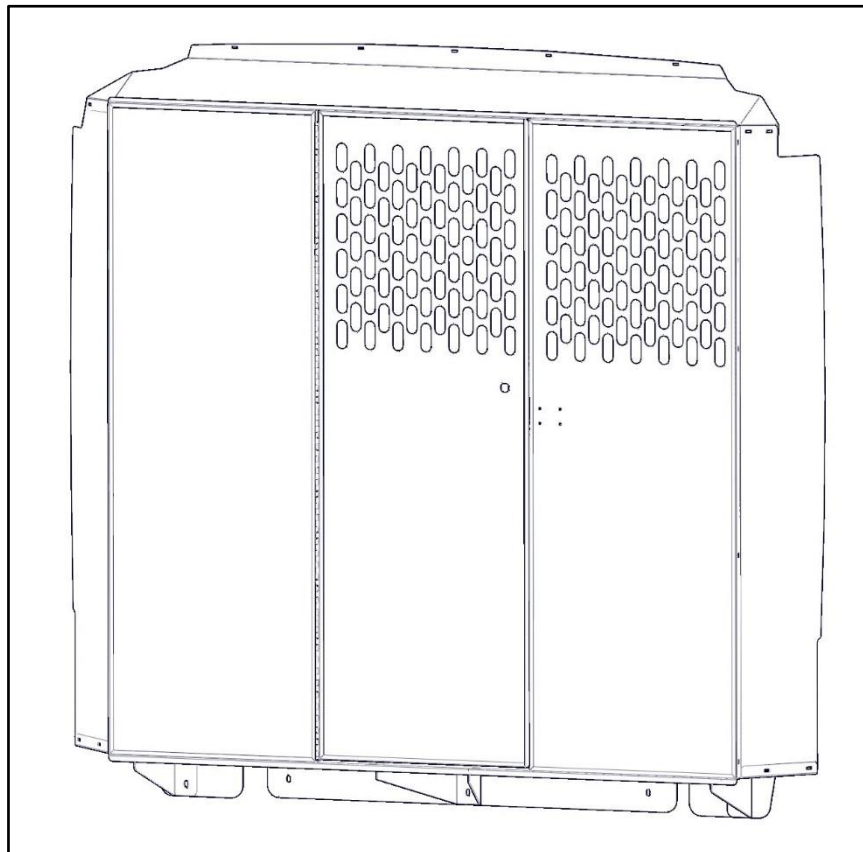

Your installation is now complete.