

KARGO MASTER[®]

WE PUT EVERYTHING WITHIN REACH.

Installation Guide

40640

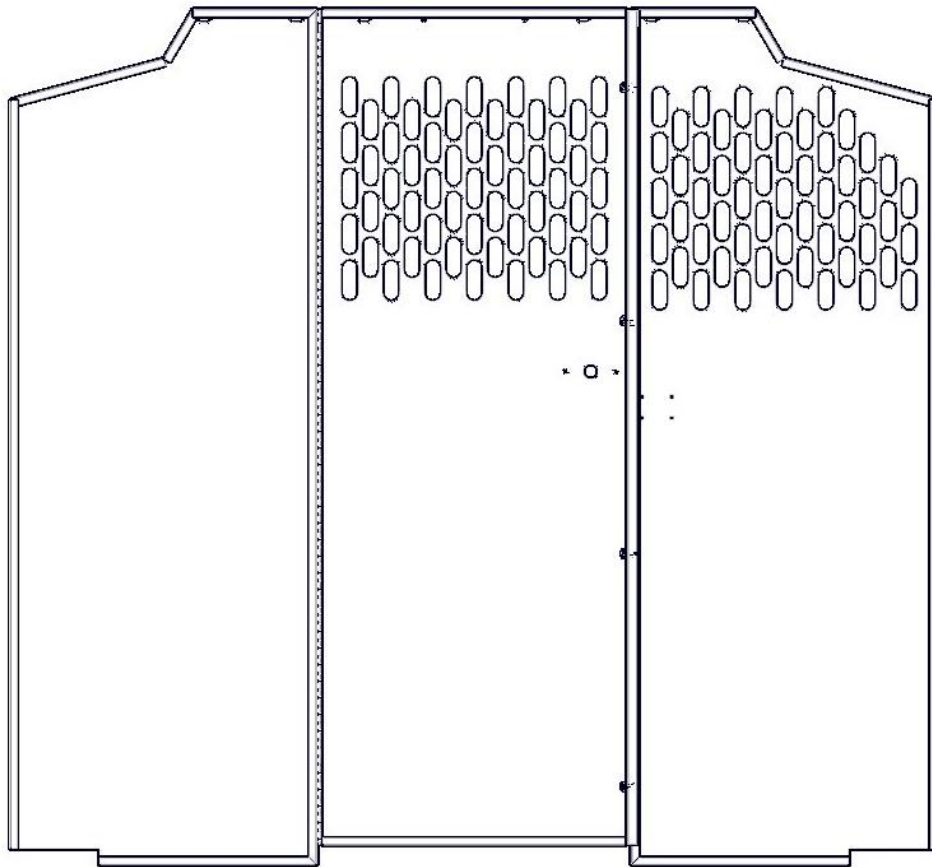

***PLEASE READ ALL INSTRUCTIONS AND WARNINGS PRIOR TO ASSEMBLING,
INSTALLING, AND USING THIS PRODUCT***

Warning



Always check for wires, fuel tanks and lines, brake lines and other important vehicle functionality items prior to drilling and installing all products.

Tools Needed

3/8" Wrench and Socket	7/16" Wrench and Socket
------------------------	-------------------------

Table of Contents

Parts List 2
Hardware List 2
Step 1 – Bolt Together 3



Before You Begin

- Read all instructions

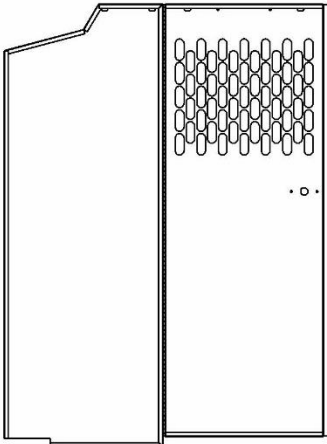
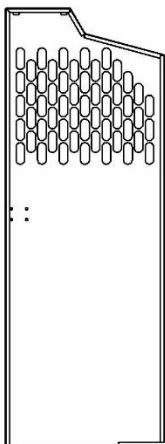
Parts

ITEM NO.	40640-R2 Parts	DESCRIPTION	QTY.
A		Door Assembly	1
B		Passenger Side Panel	1

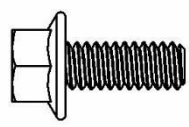
Hardware

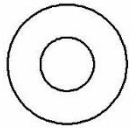
ITEM NO.	TO SCALE	PART NUMBER	DESCRIPTION	QTY.
1		92979A114	.25-20 x .625 Flange HH	4
2		93298A110	.25-20 Flanged Nyloc Nut	4
3		90126A029	.25 flat washer	8

Step 1 – Bolt Together

- Place both pieces (A&B) flat on the ground or table. Be sure to have the flanges facing upward so you can access the bolt holes.

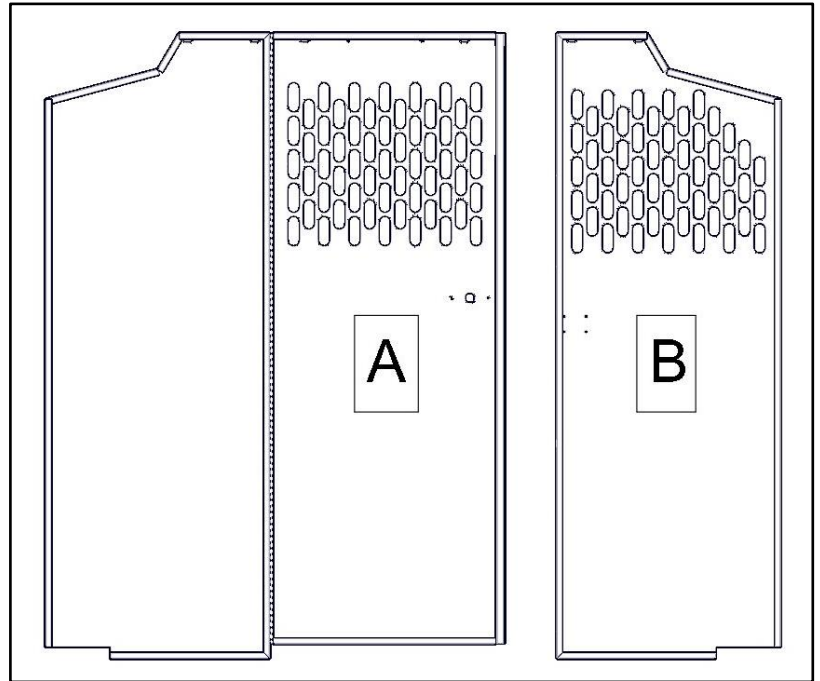

- Bolt together using a 1/4"-20 x .625" flanged hex bolt and a 1/4"-20 flanged lock nut.
- If installing the Center Panel Latch & Door Lock Kit (40620), be sure to put two flat washers in between the two panels. This is used to get correct spacing.
- If no door kit is being used the washers (3) are not needed.

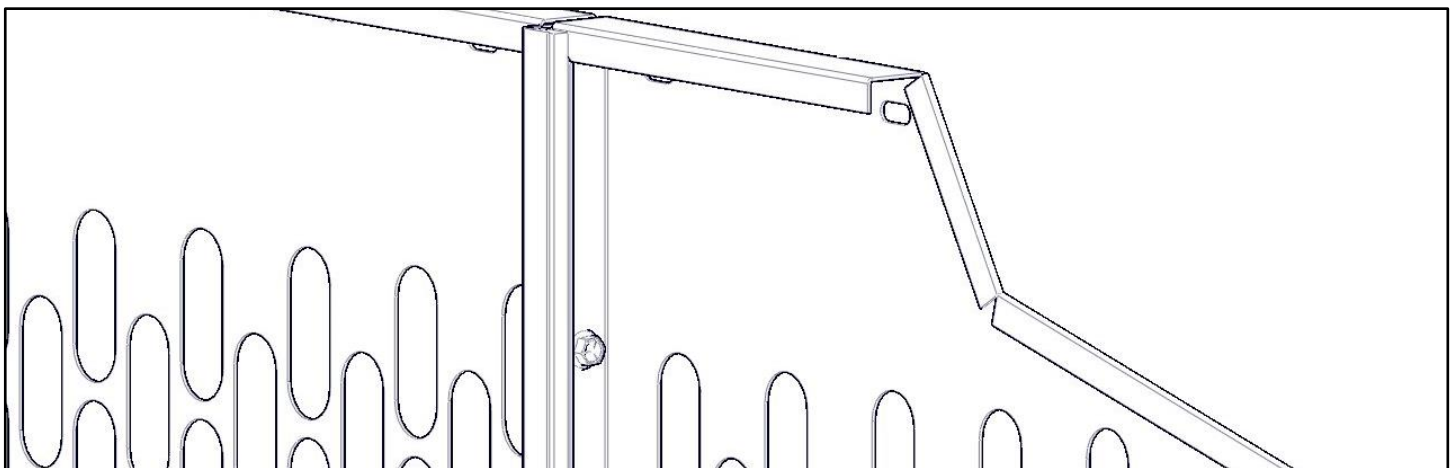
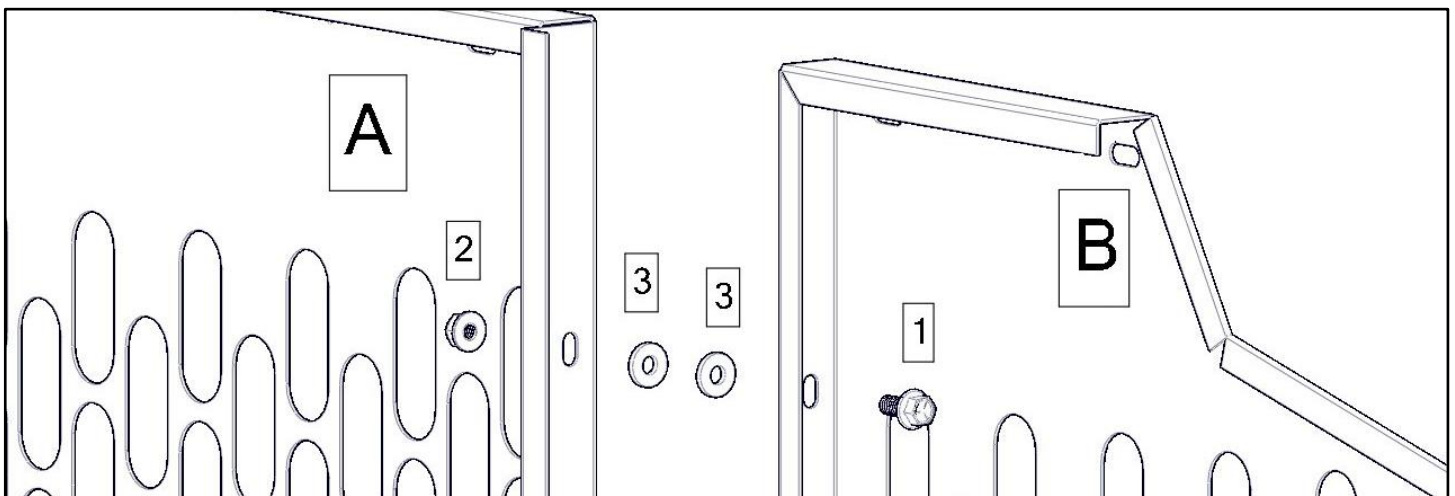

- Repeat 3 more times as shown. Be sure to insert the washers between the panels.
- Some like to leave bolts snug tight to allow movement until partition is installed into vehicle.

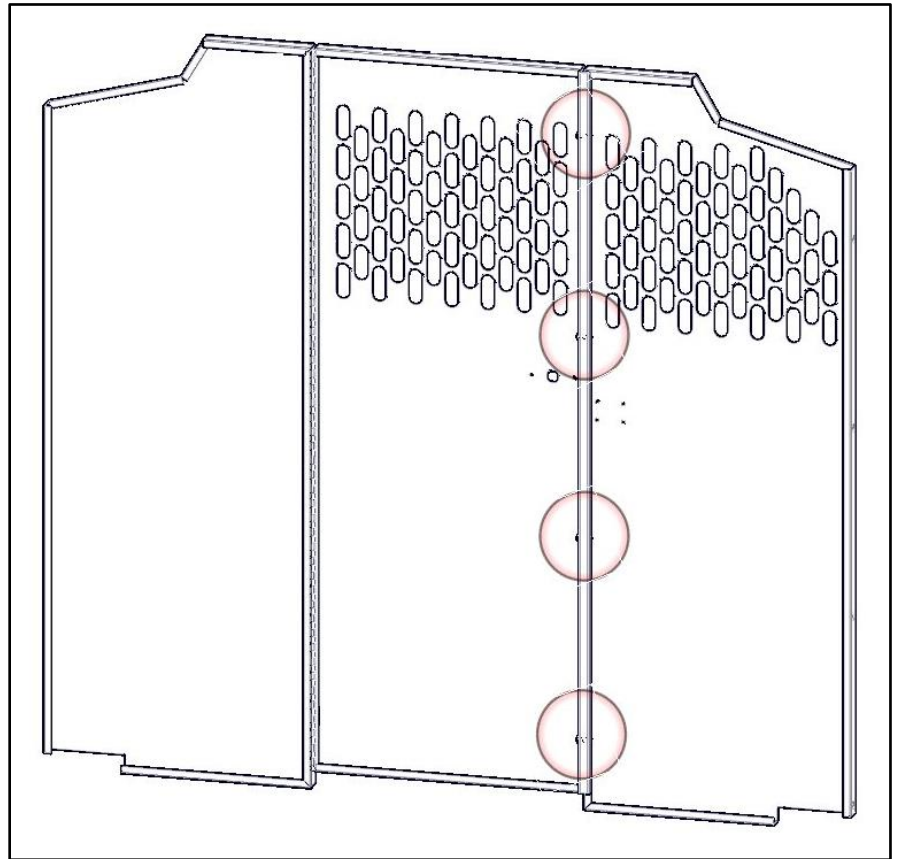

Follow instructions of desired wing kit to install into vehicle.

KARGO MASTER[®]

WE PUT EVERYTHING WITHIN REACH.

Installation Guide

4064M

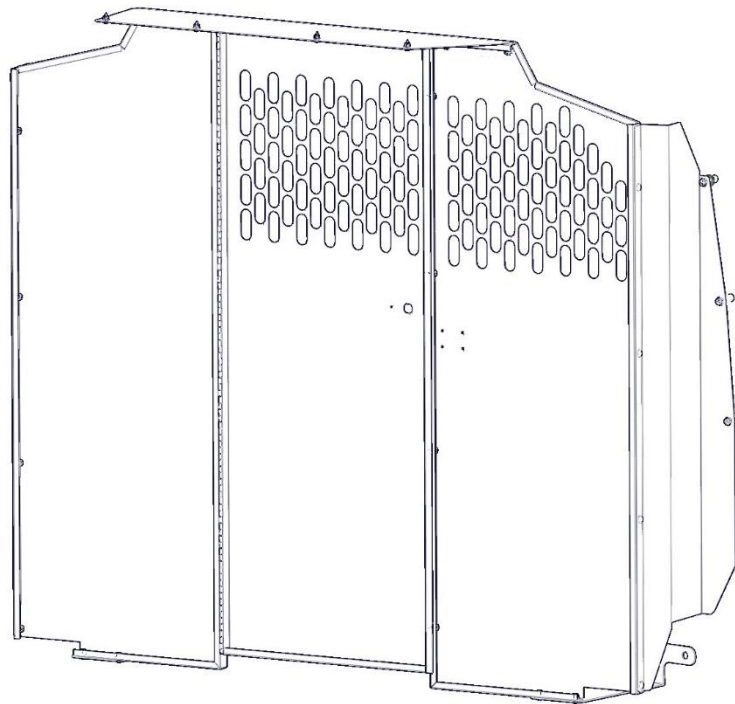

***PLEASE READ ALL INSTRUCTIONS AND WARNINGS PRIOR TO ASSEMBLING,
INSTALLING, AND USING THIS PRODUCT***

Warning



Always check for wires, fuel tanks and lines, brake lines and other important vehicle functionality items prior to drilling and installing all products.

Tools Needed

3/8" Wrench and Socket	7/16" Wrench and Socket
Phillips Driver	25/64" Drill Bit

Table of Contents

Parts List 2

Hardware List 3

Step 1 Bolt Wings to Partition 4

Step 2 Install Floor Mounts 5

Step 3 Prepare "B" Pillar 5

Step 4 Install Wings 6

Step 5 Install Partition 7

Step 6 Install Top Wing 7

Step 7 Attach Top Wing 8



Before You Begin

- Read all instructions
- ENSURE SAFETY BEFORE DRILLING OR CUTTING

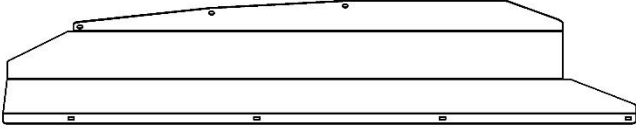
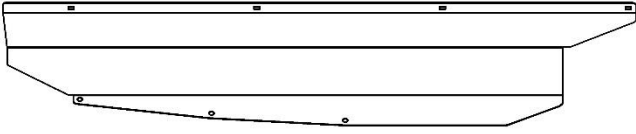
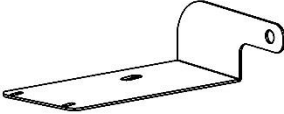
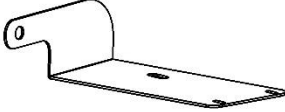
Parts

ITEM NO.		PART NUMBER	DESCRIPTION	QTY.
A		4064M-00-001	Top Wing - Metris	1
B		4064M-00-002	P_S Wing - Metris	1
C		4064M-00-002 - Mirror	D_S Wing - Metris	1
D		4064M-00-003	P_S Floor Mount - Metris	1
E		4064M-00-003 - Mirror	D_S Floor Mount - Metris	1

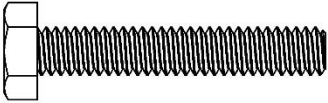
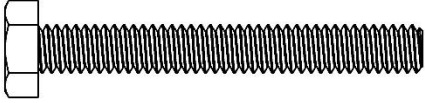
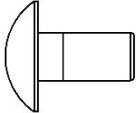
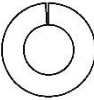
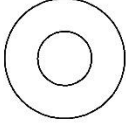
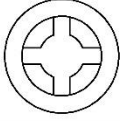
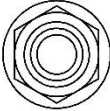
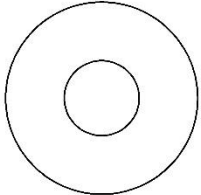
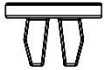
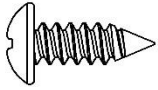
Hardware

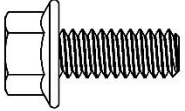
ITEM NO.	TO SCALE	PART NUMBER	DESCRIPTION	QTY.
1		92865A546	.25-20 x 1.5 HH	6
2		92865A549	.25-20 x 2 HH	6
3		.25 X .50 CARRIAGE BOLT	.25-20 x .50 Carriage Bolt	4
4		91101A229	.25 Split Lock Washer	6
5		90126A029	.25 Flat Washer	6
6		91755A225	.25 Self Retaining Washer	6
7		93298A110	.25-20 Flanged Nyloc Nut	18
8		.375 x 1.00D x .39ID Nylon Spacer	.375 x 1.00D x .39ID Nylon Spacer	12
9		Automotive Nylon Nut - AUVECO.COM P/N 8149	Plastic Nut Clip OEM 2524525	4
10		90190A293	12 x .625 Pan Head Point Screw	4
11		93669A230	.25-20 Riv Nut	6
12		92979A114	.25-20 x .625 Flange HH	14

Step 1 – Bolt Wings To Partition

- Place both passenger side wing (B) and driver side wing (C) in orientation shown with reference to the partition.

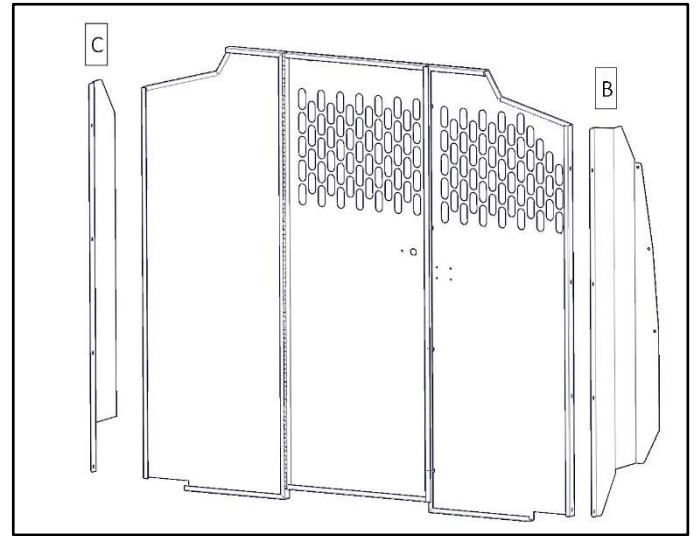

- Bolt together using a 1/4"-20 x .625" flanged HH (12) and a 1/4"-20 flanged nyloc nut (7).

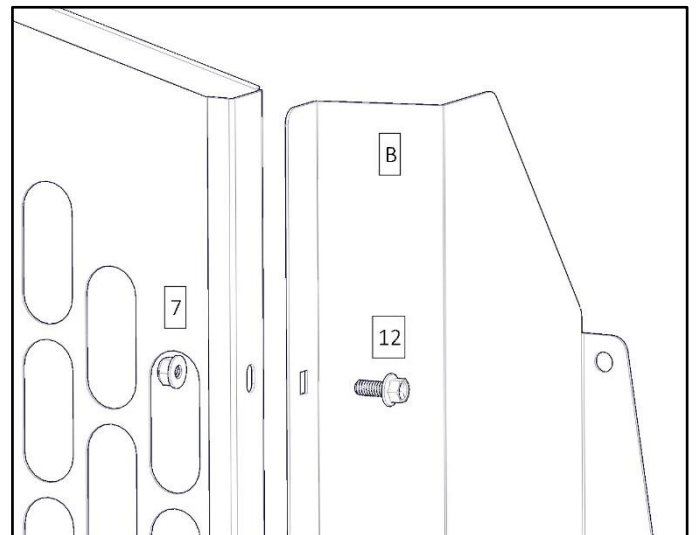

- Repeat 1 more time as shown.
- Leave bolts snug tight to allow movement until partition is placed into vehicle.
- The wings will be removed in order to install in vehicle.
- Repeat on both sides.

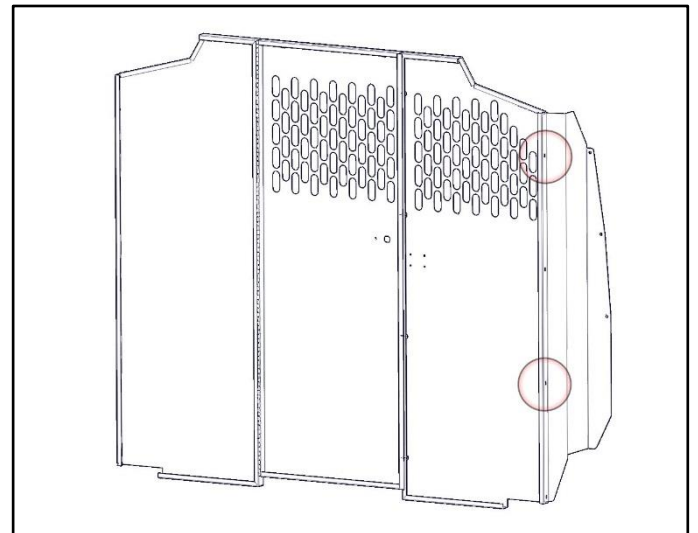

Step 2 – Install Floor Mounts

- Open slider of van, towards the front on the floor will be a D-Ring and allen head bolt.
- Remove D-Ring and bolt in the floor in the locations shown.
- Place 1/4" carriage bolts underneath the two slots at the end of each floor mount bracket (D&E).
- Place both floor mounts into van. Align with D-Ring and bolt that is in the floor. Replace D-Ring and bolt.
- Snug Tighten, But allow movement.

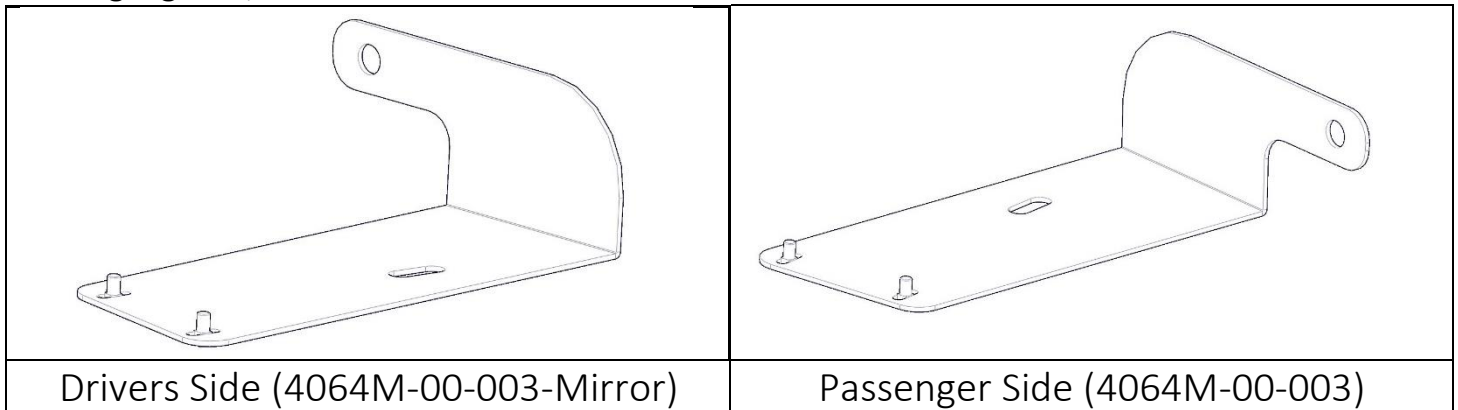
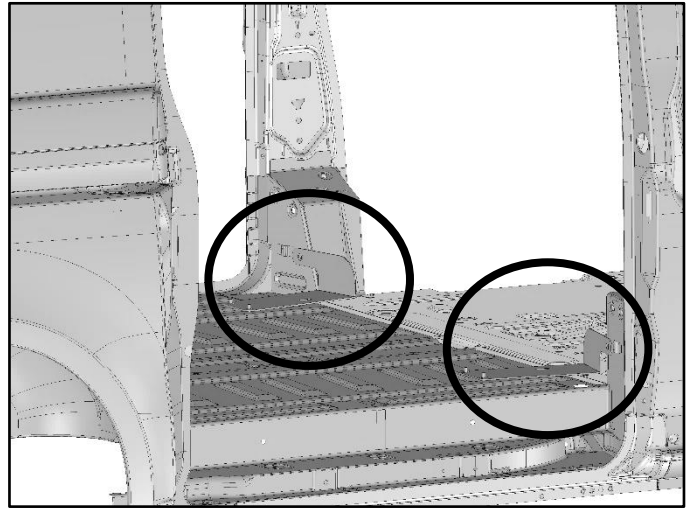

Step 3 – Prepare “B” Pillar

- Place assembled partition with wings into van. The bottom of the partition will sit on top of the 1/4" carriage bolts from Step 2.
- Have the holes in the partition on the passenger side and the wings towards the “B” pillar.

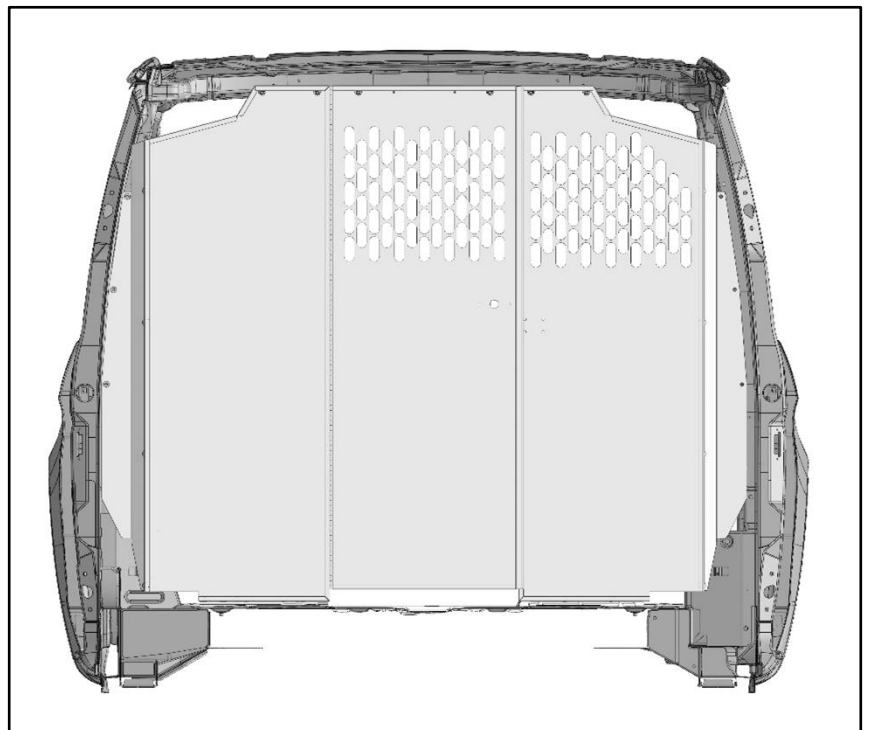

VIEW FROM REAR OF VAN

Step 3 – Prepare “B” Pillar Con’t

- Align and square partition to your liking.
- Press wings firmly against “B” pillar.
- Mark holes along each wing (3x each) and the outer edge of the wing along each “B” pillar.
- Remove partition with wings from van.
- Prior to drilling or cutting, pry plastic away to expose underside, ENSURE IT IS SAFE TO DRILL.
- Cut away plastic on “B” pillar to expose corresponding holes along the metal “B” pillar.
- Option 1, Use a 1” holesaw where holes were marked.
- Option 2, Cut along edge of wing to expose more of the metal “B” pillar. This option tends to make for an easier installation.

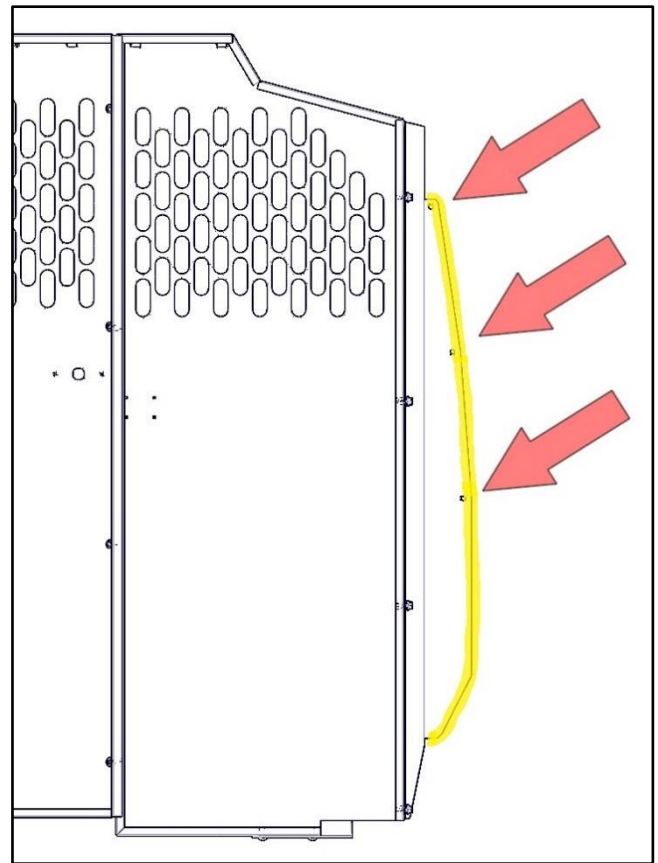

Step 4 – Install Wings

- Locate the holes that correspond with the wings along the metal “B” pillar. These holes will be where the arrows are shown in Step 3.
- Drill these 3 holes on each pillar using a 25/64” bit.
- Install RivNut.
- Bolt wings to previously installed RivNuts using 1/4" x 1.5" or 2" HH (1 or 2), 1/4" lock washer (4), 1/4" flat washer (5), two 3/8" spacers (8) and a retaining washer (6) in the order shown.
- Repeat on both sides, for a total of 6x.
- Snug Tighten, But allow movement.

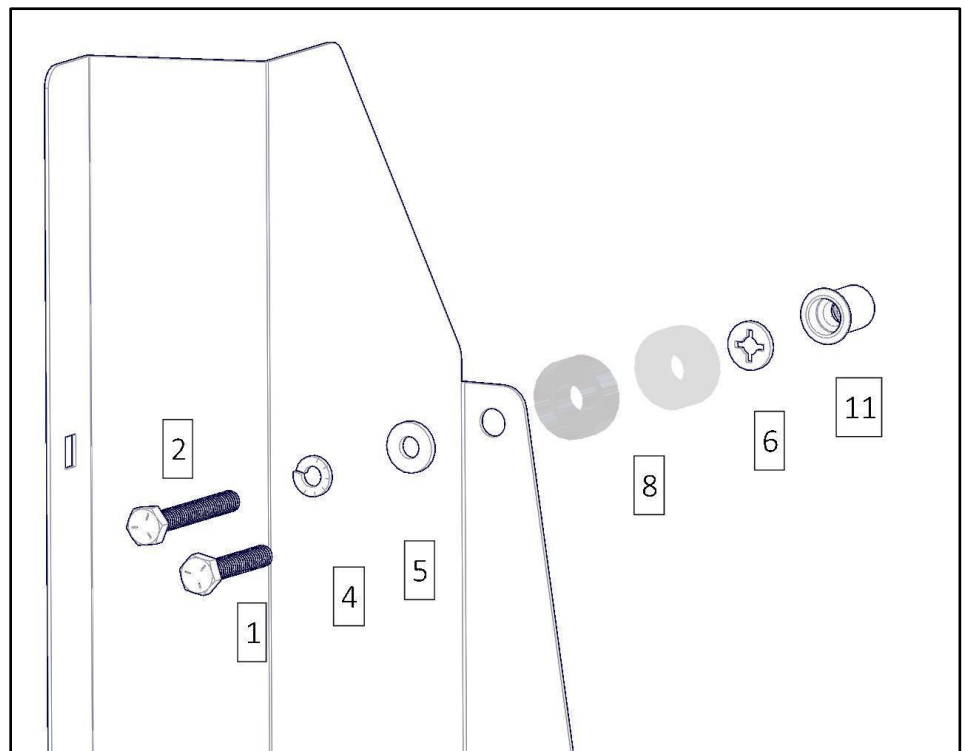

Step 7 – Attach Top Wing

- Along the roof of the van will be a cross support near the slot end of the top panel.
- Along the cross support, near the slots there will be squares cut into the cross support.
- Push plastic nut clip (9) into these squares.
- Press top wing firmly against cross support.
- Screw through the top wing into the nut clips using #12 pan head screw (10).
- Repeat for a total of 4x.

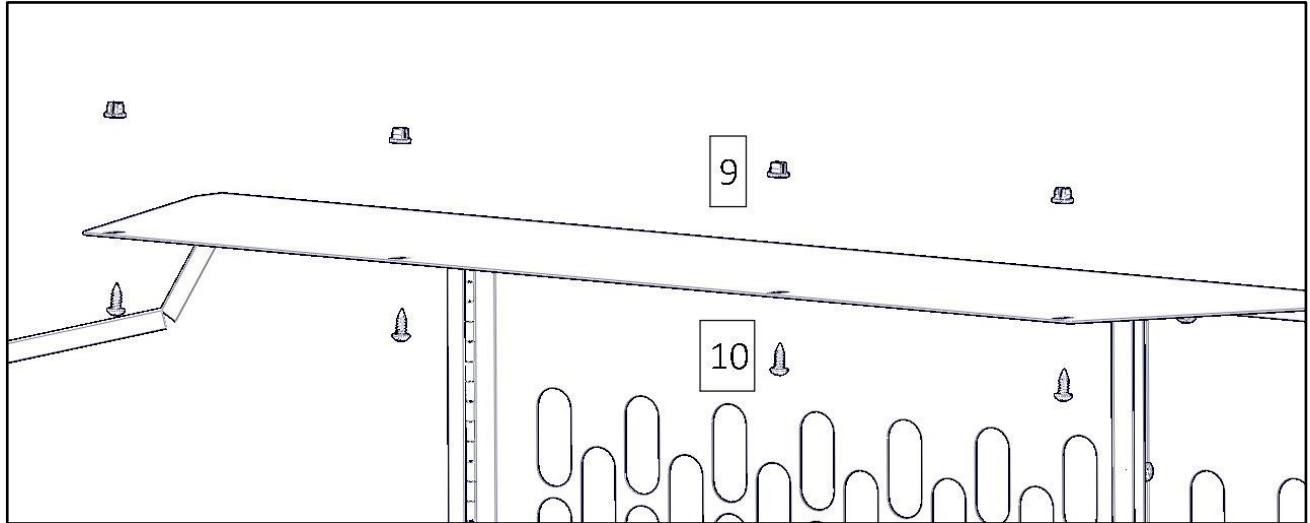

Square and align partition to your liking.
Tighten all bolts from previous steps.
Your installation is now complete.

