

---

# KARGO MASTER®

**WE PUT EVERYTHING WITHIN REACH.**

---

## Instruction Guide

---

40490

---

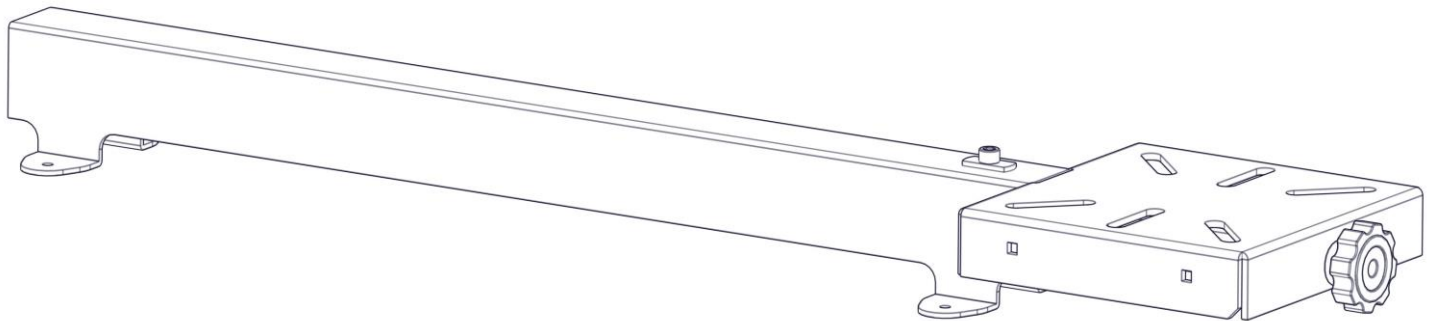

---

\*PLEASE READ ALL INSTRUCTIONS AND WARNINGS PRIOR TO ASSEMBLING,  
INSTALLING, AND USING THIS PRODUCT\*

---

## Warning



Always check for wires, fuel tanks and lines, brake lines and other important vehicle functionality items prior to drilling and installing all products.

---

## Tools Needed

7/16" Socket and Wrench	25/64" Dill Bit
5/16" Allen Wrench	Hand Drill

---



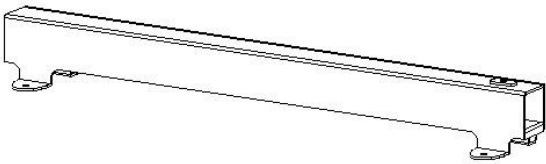
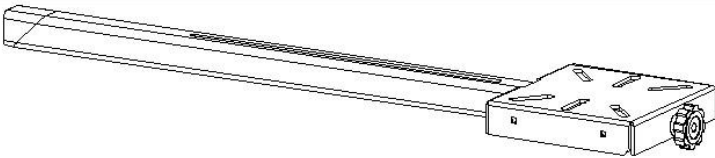

## **Before You Begin**

- Read all instructions.
  - ENSURE SAFETY WHEN DRILLING INTO VEHICLE.
-

Parts

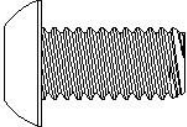
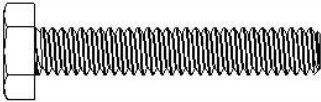
ITEM NO.		PART NUMBER	DESCRIPTION	QTY.
A		40490-10	WISE HOLDER BASE	1
B		40490-60	TELESCOPIC ARM ASSEMBLY	1
		18-40490	HARDWARE KIT	1

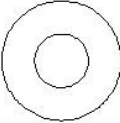
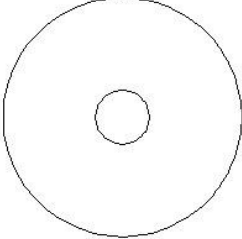
Hardware

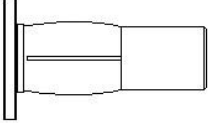
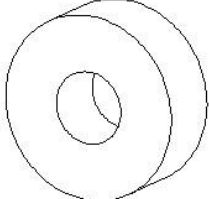
ITEM NO.	TO SCALE	PART NO.	DESCRIPTION	QTY.
1		94090	3/8-16 X 3/4" BUTTON HEAD	1
2		92865A546	1/4"-20 X 1-1/2" HEX HEAD FULLY THREADED BOLT	4
3		0123494	1/4"-20 LOCK WASHER	4
4		11541082	1/4" FLAT WASHER	4
5		33208	1/4" FENDER WASHER	4
6		0169789	1/4"-20 NYLON INSERT LOCK NUT	4
7		11120386	1/4"-20 PLUS NUT	4
8		-	3/8" ID 1" OD NYLON Spacer	4

## Step 1 – Assemble Vise Mount

- Loosen the knob on the arm assembly to allow the arm assembly to be inserted into the base.

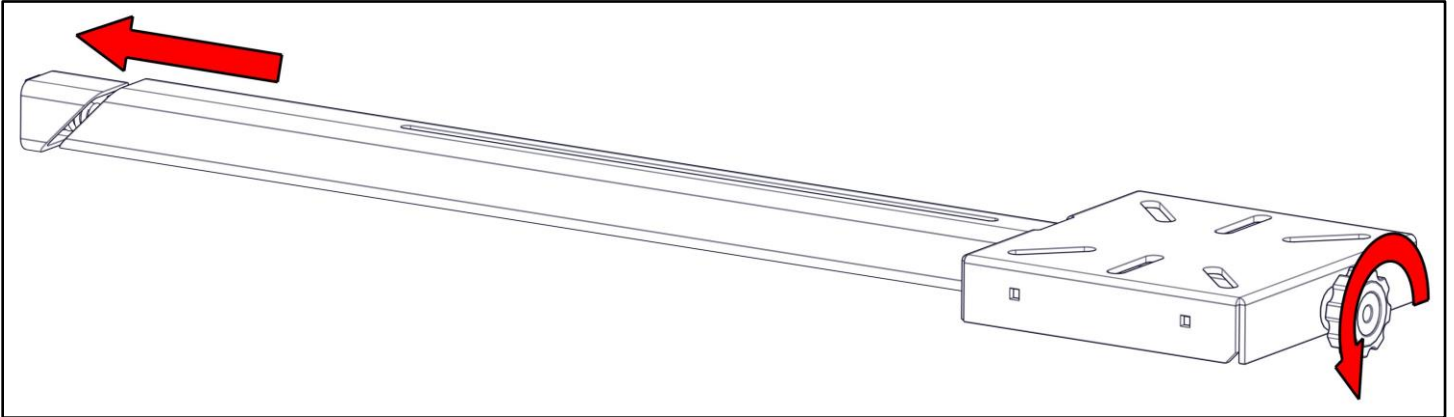

- Insert the arm assembly completely into the base in the orientation shown.

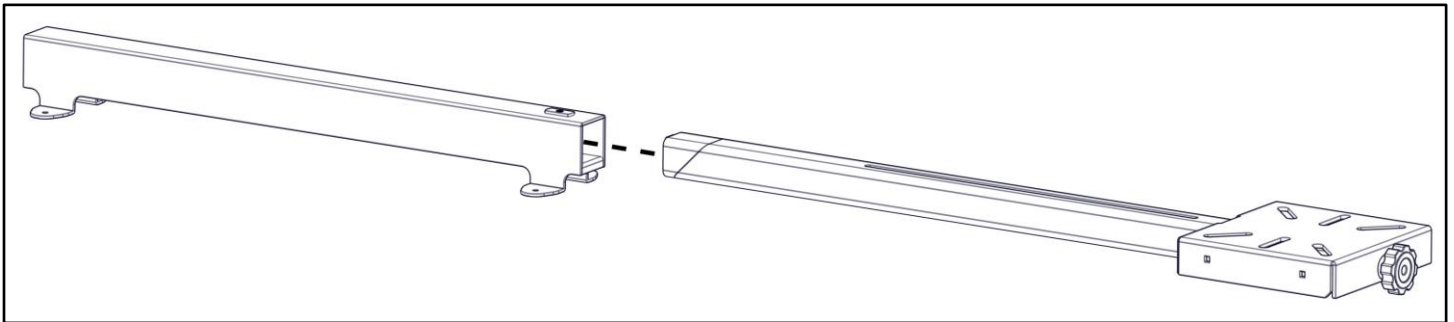

- Install 3/8" x 3/4" button head bolt into the weldnut on the base as shown.
- Tighten.

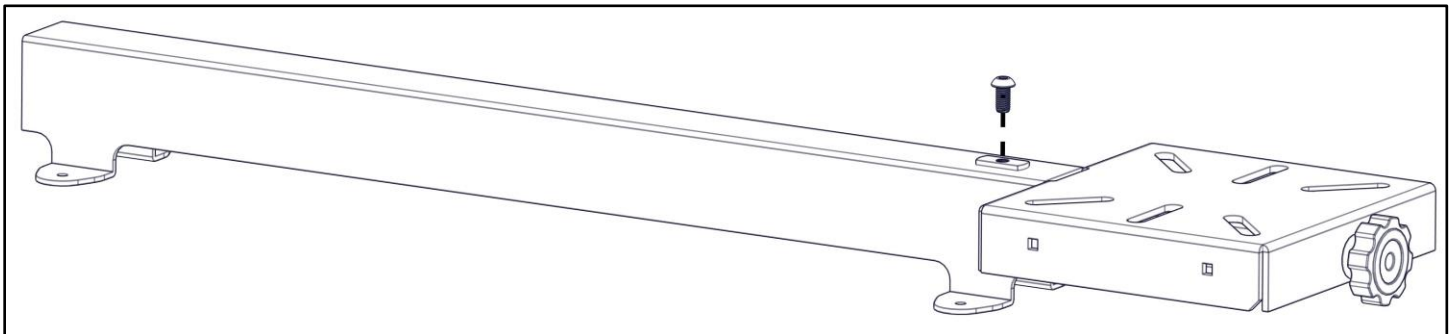

## Step 2 – Determine Location

- Determine the desired location of the vise mount and insert into the vehicle with the knob on the arm assembly is closest to the door. Typically these are installed near a door way so the vise mount can be extended outside of the vehicle.

Some location examples are shown below.

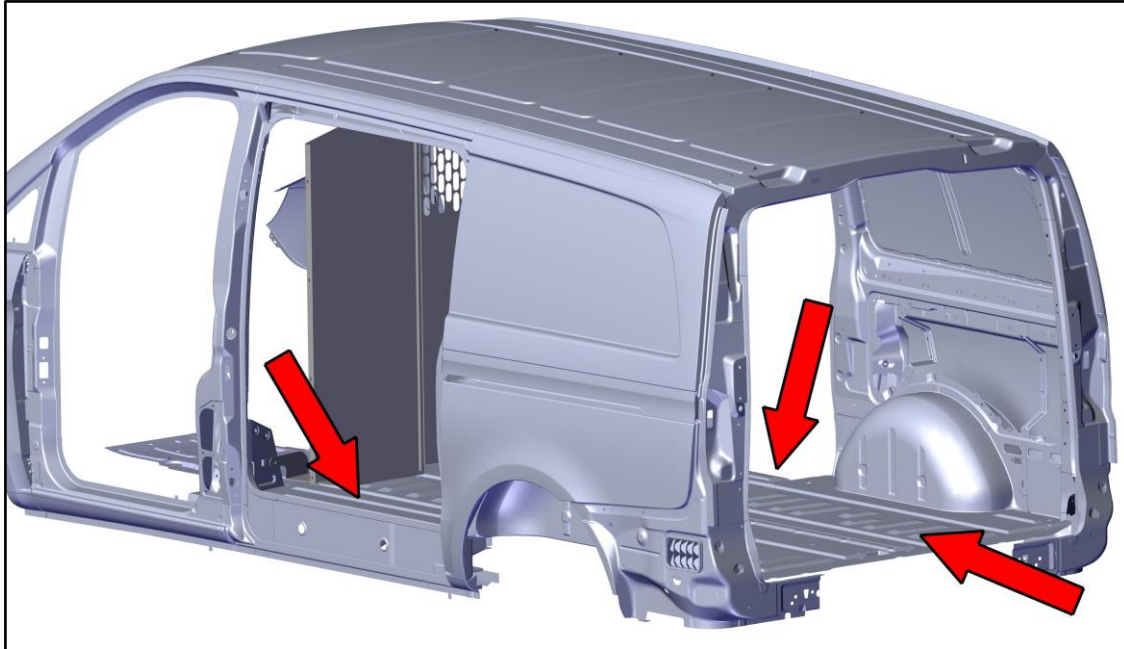

- Ensure the doors can be closed without interfering with the knob on the vise mount.
- Locate the holes in the feet of the base.
- **Be sure these locations are safe to drill through the floor. Look underneath the vehicle to ensure there are no critical components. The strongest installation allows for access from underneath vehicle.**
- Mark through the four mounts of the base onto the floor. If the mounts do not sit flat on top of a ridge in the floor, the spacers can be used to take up the vacant space.
- Move the vise mount assembly out of the way to show the marked locations.
- Drill each location using a 25/64" bit. **Use a drill stop to limit the depth of the drill.**

### Step 3 – Install Vise Mount

- Determine if the installation will use plus nuts or through bolting. If the holes are accessible from the underside of the vehicle, it is recommended to use the fender washer and nyloc nut. If the hole is only accessible from the inside of the vehicle, use the plus nut.
- If using the plus nuts, install them now.
- Place vise mount on top of the plus nuts, or the previously drilled holes. Use the nylon spacers to take up vacant space if installing on a ridge to allow rigid mounting.
- If using the plus nut, attach the vise mount to the floor using a 1/4" x 1-1/2" hex head bolt, a 1/4" split lock washer, a 1/4" flat washer.
- If through bolting, attach the vise mount to the floor using a 1/4" x 1-1/2" hex head bolt, a 1/4" flat washer, a 1/4" fender washer, and a 1/4" nyloc nut. The fender washer goes on the bottom side of the floor.
- Repeat at all four locations.

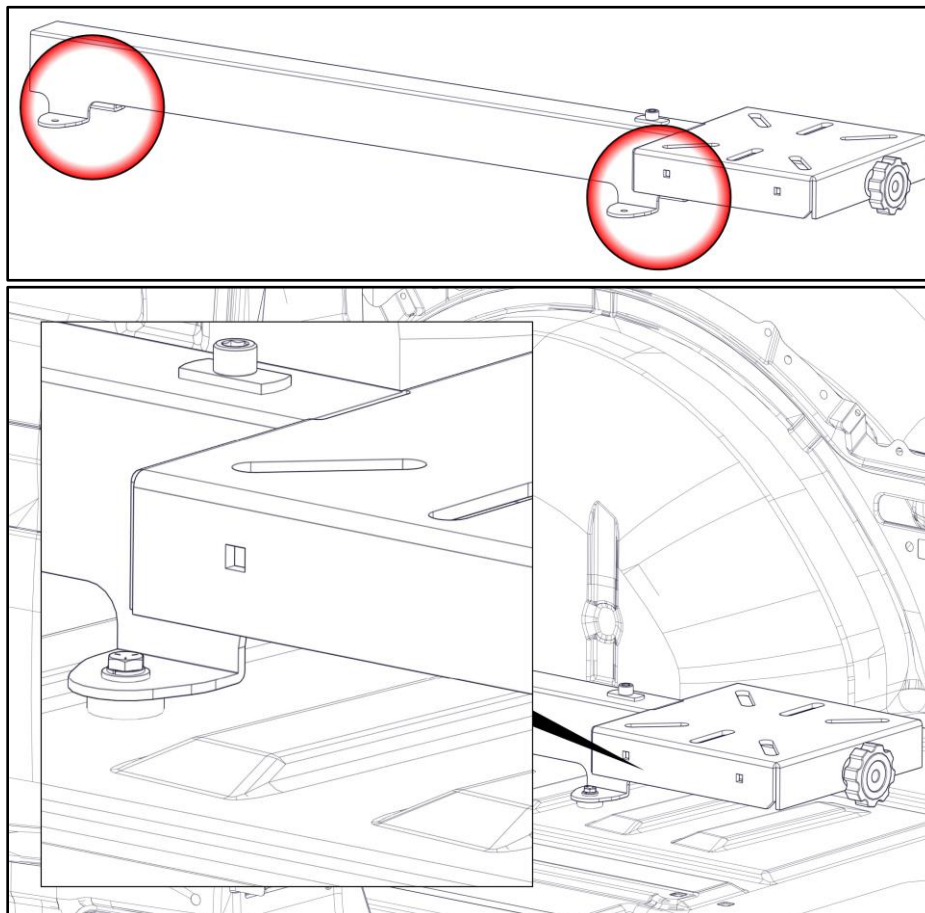
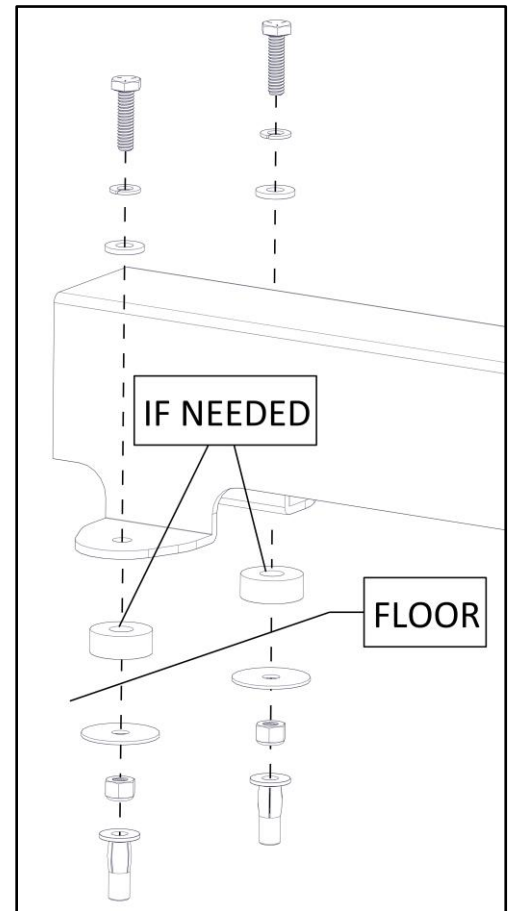



### Step 4 – Use of Vise Mount

- Install a vise at the end of the arm assembly.
- Use the knob at the end of the vise mount to tighten and loosen the arm assembly to slide the vise in and out of vehicle.

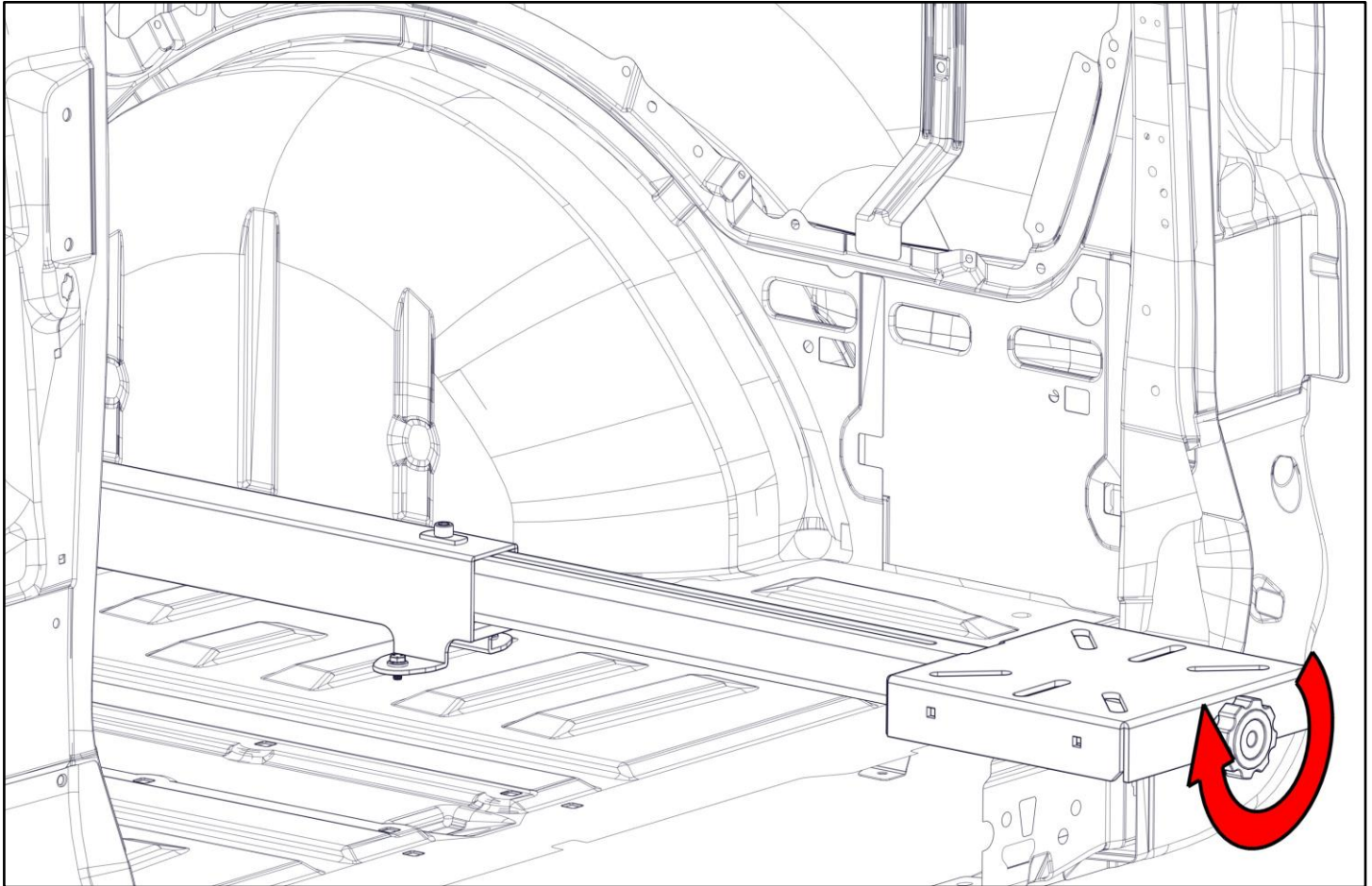

BE SURE ALL HARDWARE IS TIGHT

INSTALLATION IS NOW COMPLETE