

# KARGO MASTER®

**WE PUT EVERYTHING WITHIN REACH.**

---

## Installation Guide

40485

---

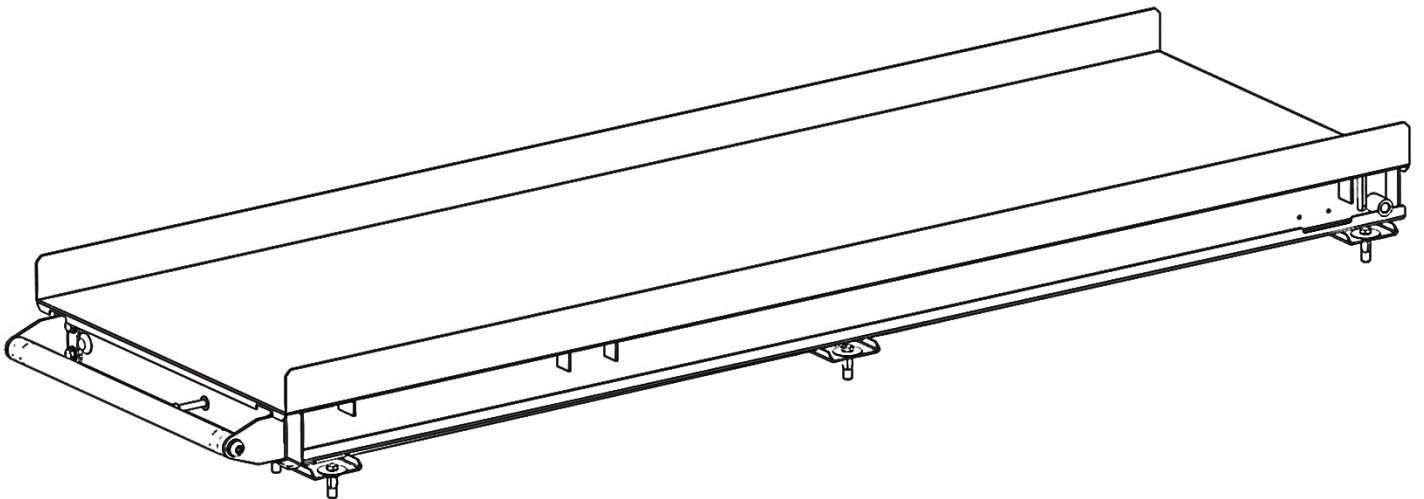

**\*PLEASE READ ALL INSTRUCTIONS AND WARNINGS PRIOR TO ASSEMBLING, INSTALLING, AND USING THIS PRODUCT.\***

**Warning**



Always check for wires, fuel tanks and lines, brake lines and other important vehicle functionality items prior to drilling and installing all products.



Secure all payloads properly for safe transportation.



Do not exceed van slide load capacity of 400 lb.



Always ensure van slide is firmly latched and locked in place before loading or unloading onto or from van slide.

**Table of Contents**

Before You Begin..... 1

Tools Needed ..... 1

Parts List..... 2

Hardware Kit ..... 2

Step 1 - Mounting Location..... 4

Step 2 - Plus Nut Installation..... 5

Step 3 - Mount Assembly Installation..... 6

Step 4 - Final Assembly ..... 6

Use ..... 8

Maintenance ..... 8



**Before You Begin**

- Read all instructions carefully, and follow each step in proper sequence, for ease and speed in assembling your Kargo Master product.
- Be sure to put sealant around all threads entering cargo area to prevent water from leaking into cargo area.

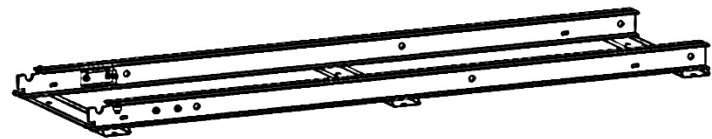

**Tools Needed**

7/16", 9/16" Box wrenches	25/65" Drill bit
5/16" Hex wrench	7/16" Deep socket w/ wrench
Drill	Drill bit stop collar
Plus Nut Installation Tool (P9902)	

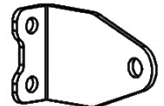
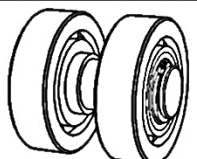
**Parts List**

ITEM NO.	ITEM	PART NUMBER	DESCRIPTION	QTY
1		100736	TOP PAN ASSEMBLY	1
2		1058C-10-R2	MOUNT ASSEMBLY WITH PARTS	1
3		1058C-01	PULL HANDLE ASSEMBLY	1
4		1058C-20-006	MAIN HANDLE BRACKET	2
5		100883	VAN SLIDE FRONT BEARING ASSEMBLY	2
6		18-40485	40485 HARDWARE KIT	1

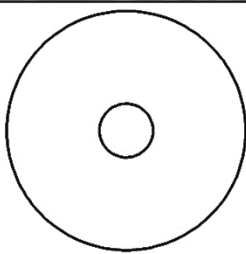
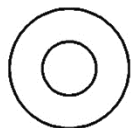
**Hardware Kit**

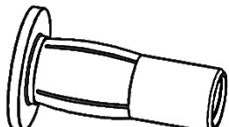
ITEM	HARDWARE TO SCALE	PART NUMBER	DESCRIPTION	QTY.
1		33208	1/4" FENDER WASHER	13
2		11541082	1/4" FLAT WASHER	4
3		1133618	1/4"-20 LOCK WASHER	17
4		920313726	1/4"-20 PLUS NUT	13

**Hardware Kit (Cont.)**

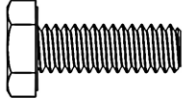
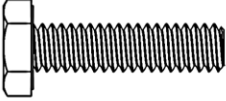
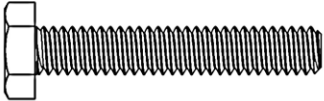
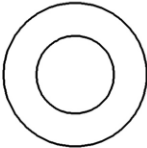
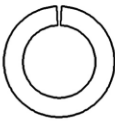
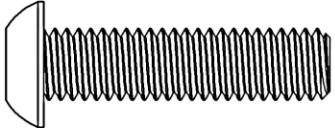
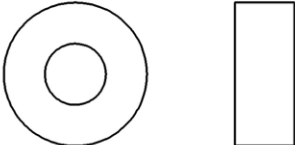
ITEM	HARDWARE TO SCALE	PART NUMBER	DESCRIPTION	QTY.
5		13001	1/4"-20 X 3/4" HEX HEAD BOLT	4
6		13005	1/4"-20 X 1" HEX HEAD BOLT	13
7		92865A546	1/4"-20 X 1-1/2" HEX HEAD FULLY THREADED BOLT	12
8		11541089	3/8" WASHER	2
9		0123496	3/8" SPLIT LOCK WASHER	2
10		0180040	3/8"-16 X 1-1/2" BUTTON HEAD CAP SCREW	2
11		-	25/64" ID X 1" OD X 3/8" NYLON SPACER	12

### Step 1 - Mounting Location

- Ensure there is enough clearance for van slide without interfering with partition or other equipment.

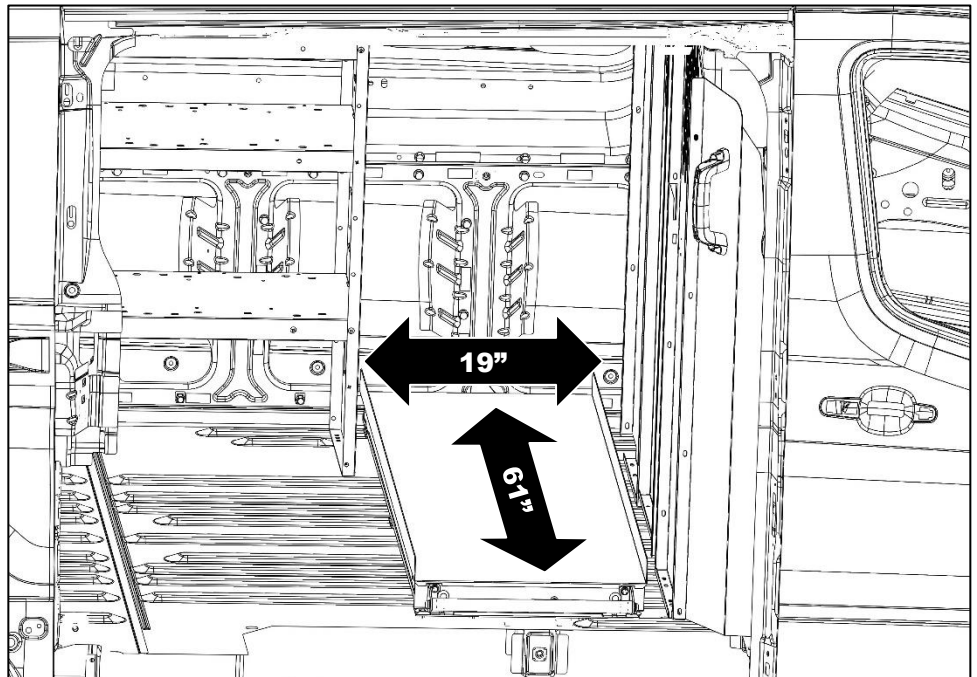

- Position mount assembly in desired location in vehicle. Be sure to allow enough clearance in front of slide rails to close van side door.
- Verify that each mounting location is clear of wires, fuel tanks and lines, brake lines and other important vehicle functionality items prior to drilling.
- Mark through each mounting location onto vehicle floor.

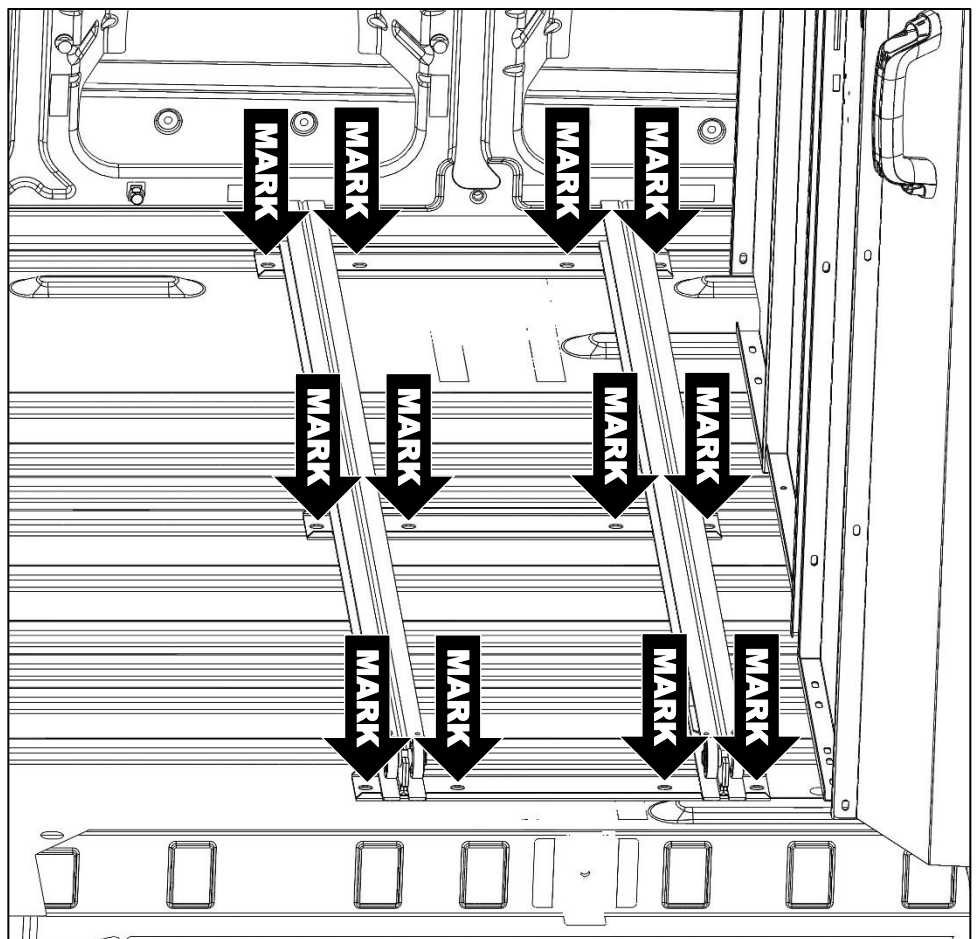

## Step 2 - Plus Nut Installation



**DO NOT drill beyond depth of floor. Always check for wires, fuel tanks and lines, brake lines and other important vehicle functionality items prior to drilling and installing all products.**

- Drill hole using 25/64" drill bit and appropriate sized drill-bit stop collar. If 25/64" drill bit is not available, a 3/8" drill bit can be used, although it may be necessary to tap in the plus nuts.
- Insert 1/4" x 2-1/4" hex head bolt through 1/4" flat washer and plus nut installation tool, and then screw bolt into plus nut. Knurled end of plus nut tool must be directed away from bolt head and contacting plus nut.
- Insert plus nut with tool into hole.
- Using the 9/16" box wrench, hold the plus nut tool stationary and then tighten hex head bolt until plus nut is tightly gripping and does not spin when hex bolt is loosened.
- DO NOT overtighten plus nut.
- Using the 9/16" box wrench, hold the plus nut tool stationary to remove the 1/4" hex head bolt.

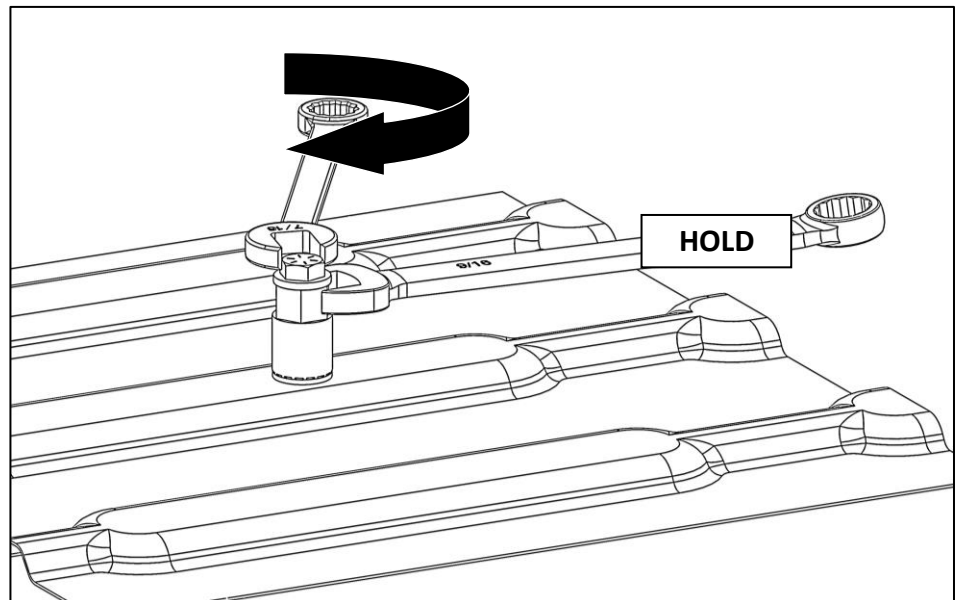
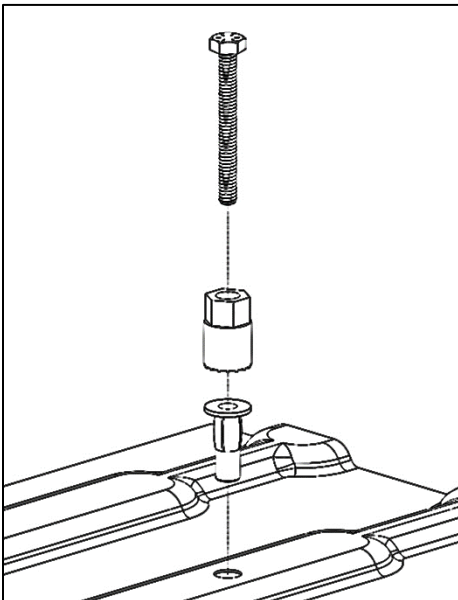

**Step 3 - Mount Assembly Installation**

- Using one 1/4" x 1" hex head bolt, one 1/4" lock washer, and one 1/4" fender washer at each mounting location, fasten the mount assembly to the vehicle floor.

**NOTE:** If any of the mounting locations are over a floor channel depression, use one 1/4" x 1-1/2" hex head bolt and one nylon spacer between the bottom of the slide rails and the depression in the floor.

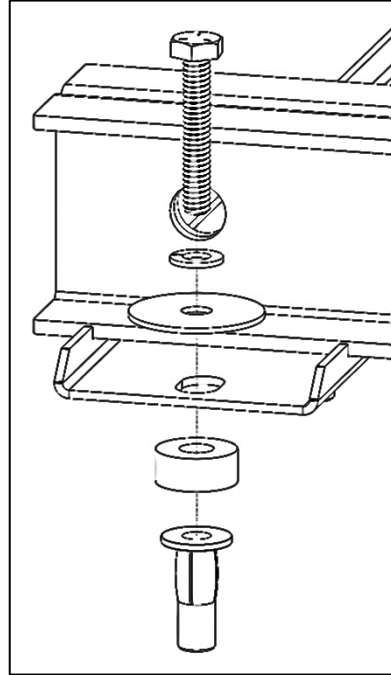
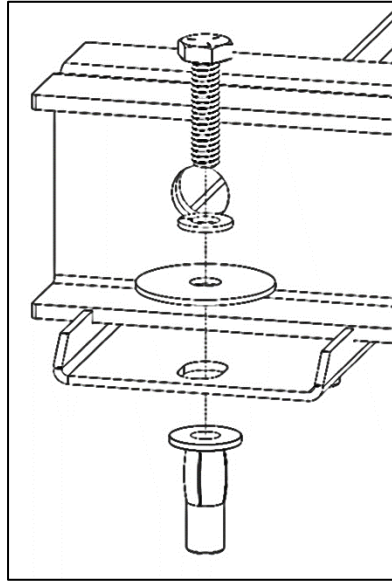

**Step 4 - Final Assembly**

- Insert bearing assemblies into mount assembly as shown. Press down on bearing assemblies to ensure they seat properly.

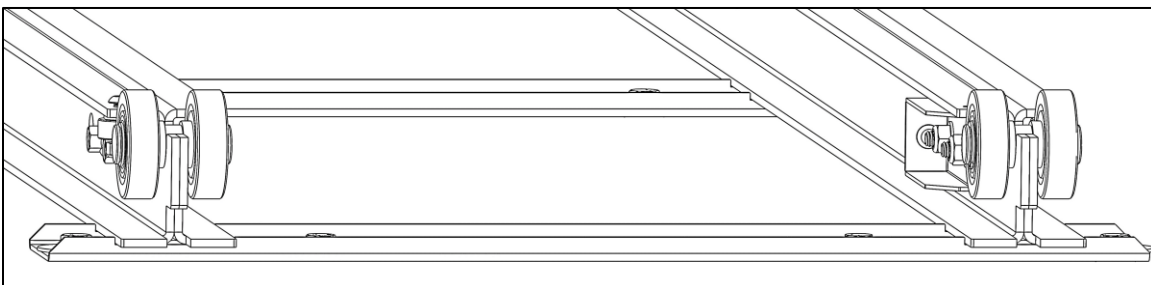
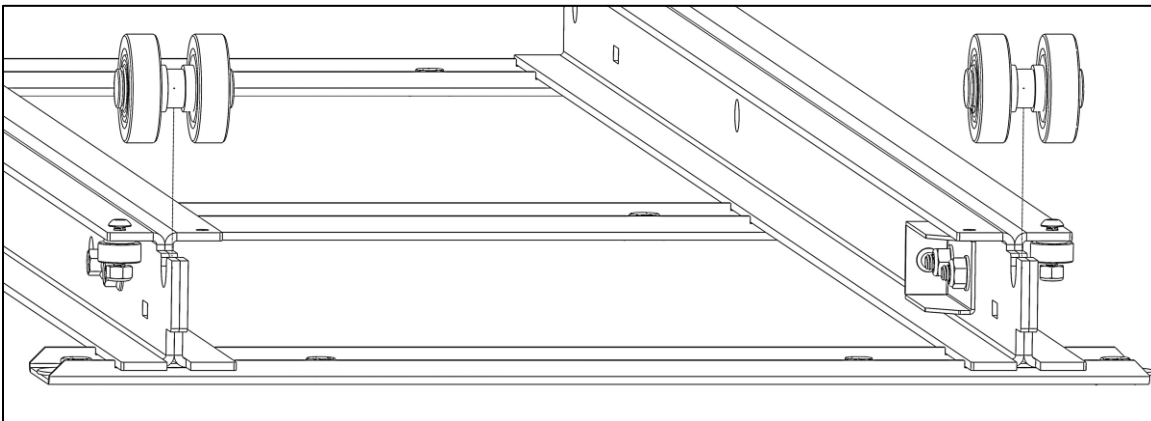

- Be sure bearing assembly is centered on mount assembly.

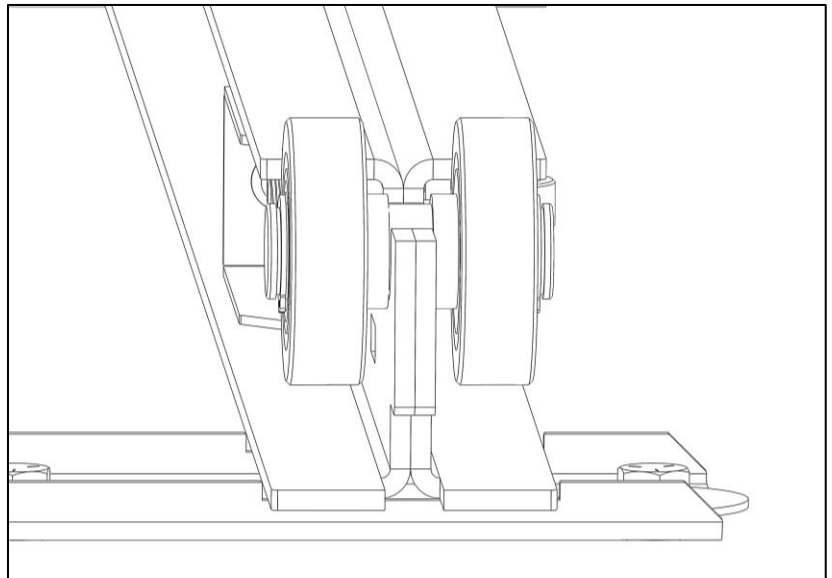

- Lay top pan assembly on flat surface.
- Using four 1/4" x 3/4" hex head bolts, four 1/4" lock washers, and four 1/4" flat washers, fasten handle brackets to top pan assembly in orientation shown.

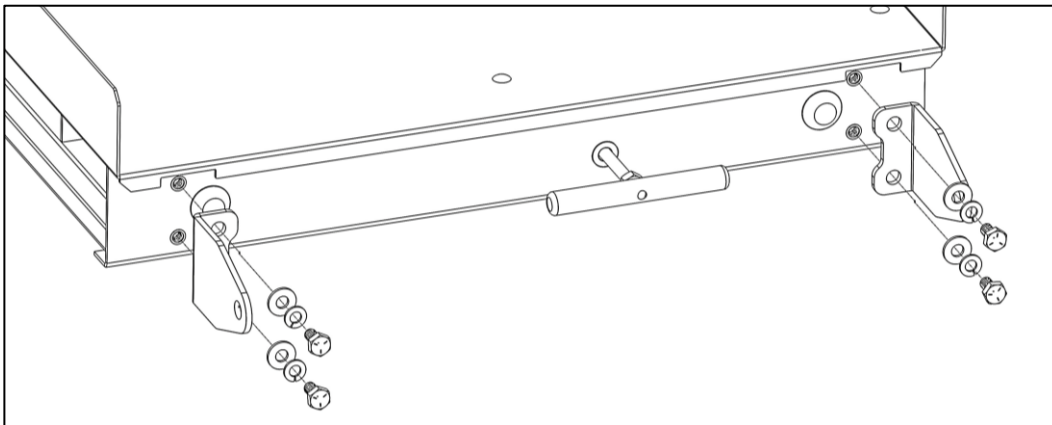

- Using two 3/8" x 1-1/2" button head screws, two 3/8" lock washers, and two 3/8" flat washers, install the pull handle assembly to the handle brackets. **DO NOT** overtighten.

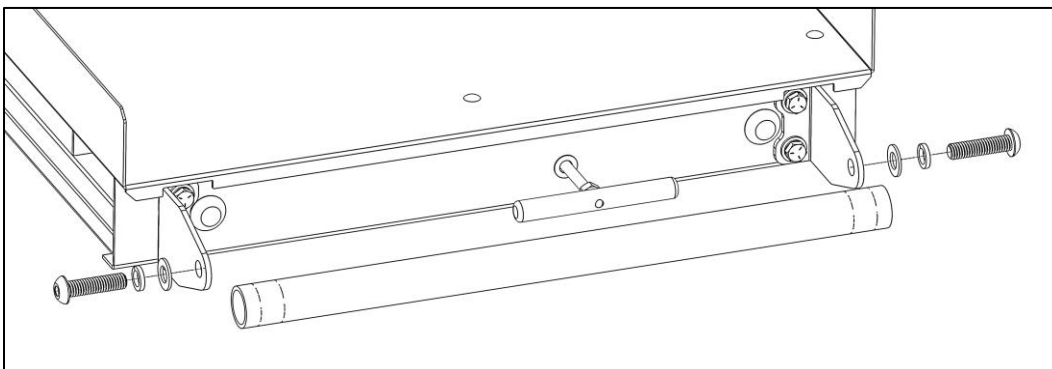



- Pull and hold latch handle forward.

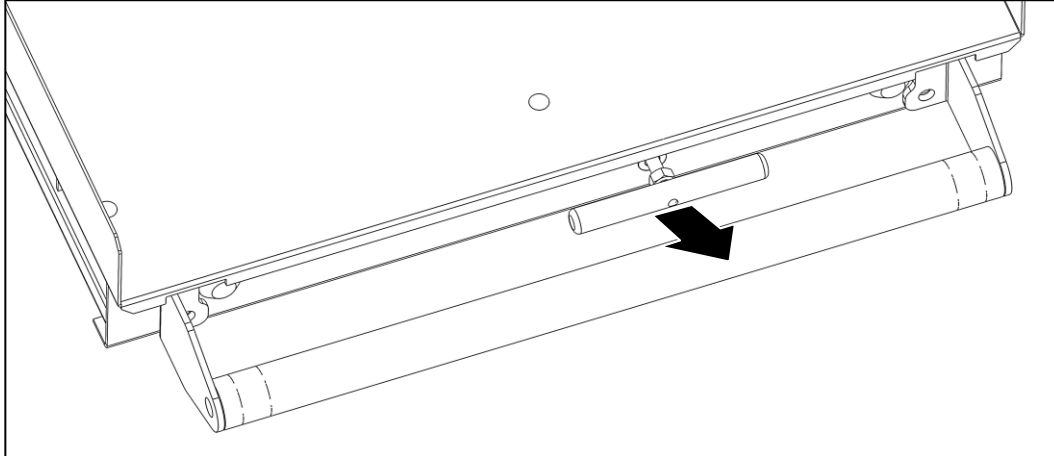

- While holding the latch handle forward on the top pan assembly, position the rear of the top pan assembly centered side to side over the mount assembly.
- Push the top pan assembly back until it drops into place beyond the slide rails.

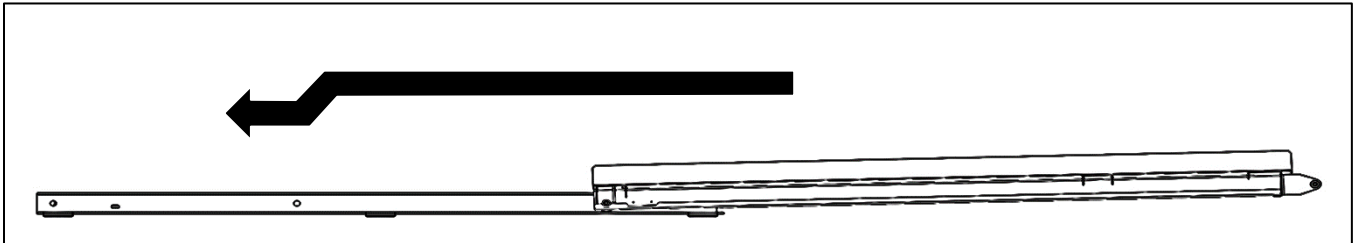

- Still holding the latch handle, pull the main handle and latch handle until the top pan assembly engages the mount assembly.
- Let go of the latch handle and push the sliding tray all the way back onto the slide rails until the latch locks.

## **INSTALLATION IS NOW COMPLETE**

### **Use**

- There are three distinct locking positions.
- To unlock, pull the latch handle and move backward or forward. Let go of latch handle during movement and top pan will automatically latch in place in next position.
- Always ensure van slide is firmly latched and locked in place before loading or unloading from van slide.

### **Maintenance**

- It is recommended to keep the inside and outside track areas clean and clear of debris to allow smooth movement of top pan.

