

# KARGO MASTER®

WE PUT EVERYTHING WITHIN REACH.

---

## Installation Instructions

40480

---

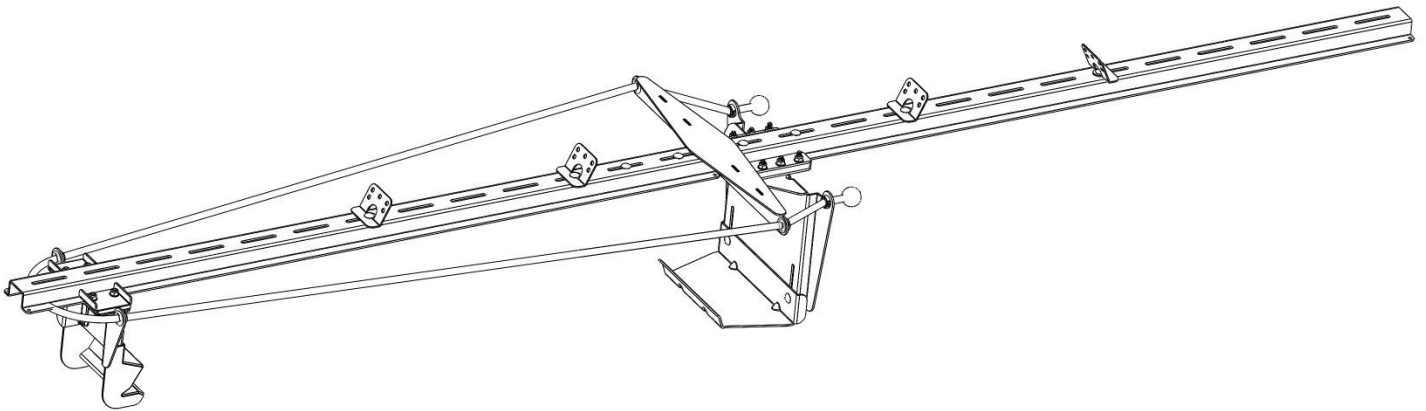

**\*PLEASE READ ALL INSTRUCTIONS AND WARNINGS PRIOR TO ASSEMBLING, INSTALLING, AND USING THIS PRODUCT.\***

Warning



Always check for wires, fuel tanks and lines, brake lines and other important vehicle functionality items prior to drilling and installing all products.

Tools Needed

7/16" Box Wrench	3/16" Allen Wrench
1/2" Socket and Socket Wrench	Hand Drill
25/64" Drill Bit	Torpedo Level
Marking Pencil	

Table of Contents

Parts List..... 2

Assembly Hardware ..... 3

Mounting Hardware ..... 4

Plus Nut Installation ..... 5

Bungee Cord Cutting Guidelines..... 5

Step 1 – Mounting Bracket Installation..... 5

Step 2 – Ladder Catch Assembly..... 8

Step 3 – Mounting the Rail ..... 9



Step 4 – Bungee Assembly..... 11

Use Instructions..... 13



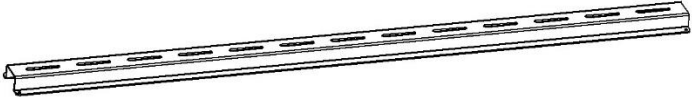
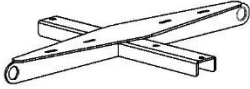
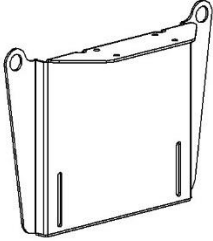
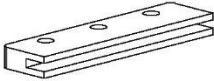

Before You Begin

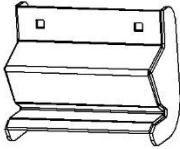
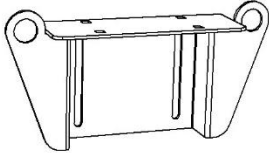
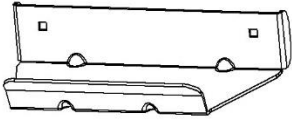
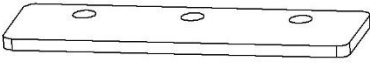
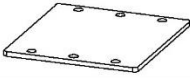
- Read all instructions. Locate your mounting locations prior to rack assembly.
- **DO NOT EXCEED MANUFACTURERS WEIGHT CAPACITY FOR ROOF.**
- **BE SURE TO ADJUST LADDER BUNGEE CLAMP ACCORDINGLY TO FIRMLY SECURE LADDER TO RACK.**
- **ENSURE SAFETY WHILE INSTALLING OR DRILLING INTO VEHICLE.**



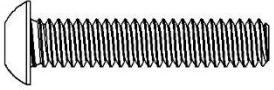
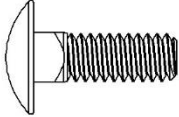

**Parts List**

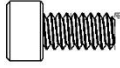
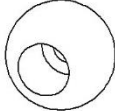
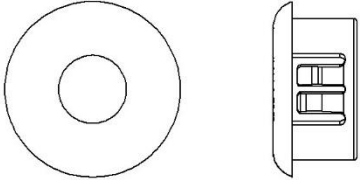
ITEM NO.	ITEM	PART NUMBER	DESCRIPTION	QTY.
1		100500	HORIZONTAL RAIL	2
2		100501	CENTER SUPPORT	1
3		100502	SLIDING BRACKET	1
4		100503	SLIDER BLOCK, PLASTIC	2
5		100505	CLAMPING BRACKET	2
6		100509	FIXED END LADDER CATCH BRACKET	1
7		100510	REAR SUPPORT BRACKET	1
8		100511	SLIDING BRACKET	1
9		100655	UPPER SLIDER BRACKET	2
10		100658	LOWER SLIDER BRACKET	1
11		18-40480A	ASSEMBLY HARDWARE	1
12		18-40480M	MOUNTING HARDWARE	1

**Assembly Hardware**

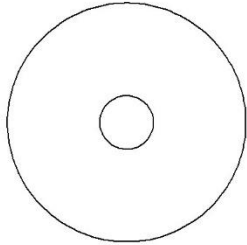
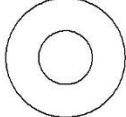
ITEM	HARDWARE TO SCALE	PART NUMBER	DESCRIPTION	QTY.
1		0167030	1/4"-20 FLANGED LOCK NUT	19
2		1133618	1/4"-20 LOCK WASHER	1
3		94054	1/4"-20 X 1-1/4" BUTTON HEAD CAP SCREW	6
4		21913	1/4"-20 X 3/4" CARRIAGE BOLT	13
5		37515	10-24 NYLON INSERT LOCK NUT	1
6		11137140	10-24 x 3/8" SOCKET CAP SCREW	1
7		B07L24CVQC	BUNGEE BALL, 8MM (1:2 SCALE)	2
8			BUNGEE CORD, 8MM	1
9		2535	SNAP BUSHING	6

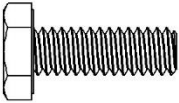
**Mounting Hardware**

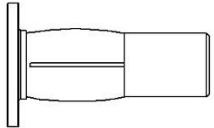
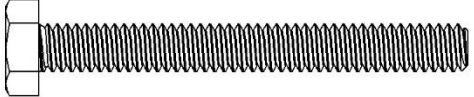
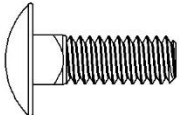
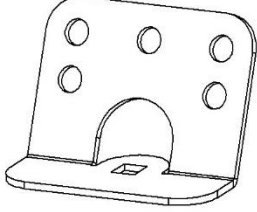
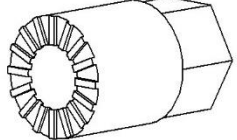
ITEM	HARDWARE TO SCALE	PART NUMBER	DESCRIPTION	QTY.
1		33208	1/4" FENDER WASHER	4
2		11541082	1/4" FLAT WASHER	1
3		0167030	1/4"-20 FLANGED LOCK NUT	4
4		11241345	1/4"-20 X 3/4" HEX HEAD BOLT	8
5		1133618	1/4"-20 LOCK WASHER	8
6		11120386	1/4"-20 PLUS NUT	9
7		0144537	1/4"-20 X 2-1/4" HEX HEAD SCREW	1
8		21913	1/4"-20 X 3/4" CARRIAGE BOLT	4
9		100506	BRACKET, MOUNTING, INTERNAL LADDER RACK (SCALE 1:2)	4
10			TOOL, INSTALLATION, PLUSNUT, 5/16"	1

## Plus Nut Installation

- Drill hole using 25/64" drill bit. If 25/64" drill bit is not available, a 3/8" drill bit can be used, although it may be necessary to tap in the plus nuts.
- Insert 1/4" x 2-1/4" hex head bolt through 1/4" flat washer and then through plus nut installation tool. Knurled end of plus nut tool must be directed away from bolt head.
- Tighten hex head bolt until plus nut is tightly gripping and does not spin when hex bolt is loosened.

## Bungee Cord Cutting Guidelines

- Determine location to cut.
- Wrap packing tape or other permanent tape around bungee cord, centered at location.
- Use either a hot knife or a razor knife to cut through center of tape.
- Burn each end until just melting materials together.

## Step 1 – Mounting Bracket Installation

- Obtain four 1/4" x 3/4" carriage bolts and four 1/4" lock nuts from assembly hardware package.
- Lightly attach the horizontal rails to the center support using four 1/4" x 3/4" carriage bolts and four 1/4" lock nuts. Do not secure tightly as the assembly may need adjustment or modification.

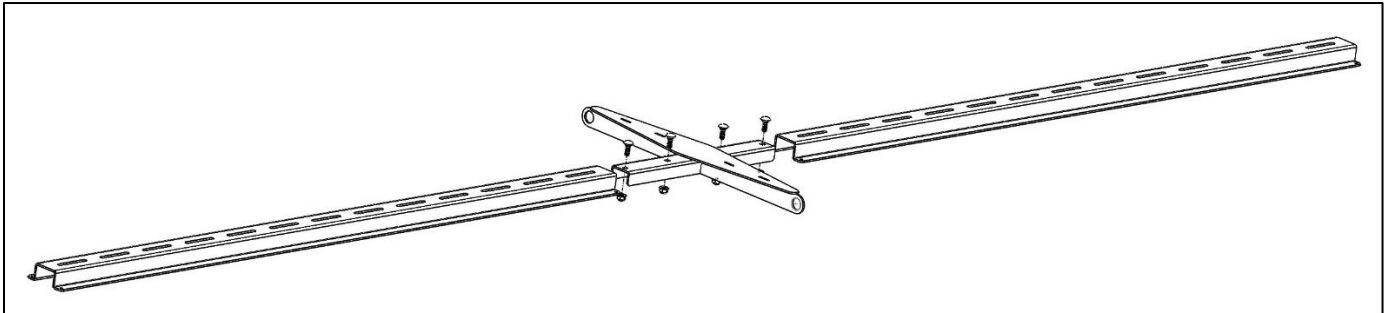

- Locate and mark center of roof support beams.
- Hold rail assembly against center of roof support beams.

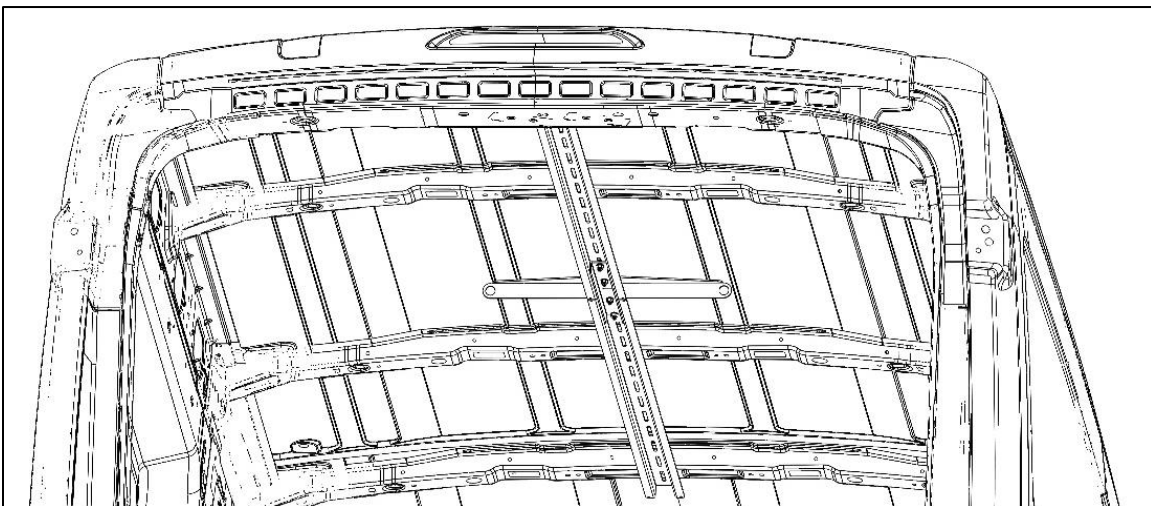

- If the rail assembly is too long, either mark or measure the length of horizontal rail that needs to be removed. The length of the uncut assembled rail assembly is 96".



- To cut off a section of horizontal rail, disassemble the rail assembly, cut the desired length from the REAR end rail, and reassemble rail assembly with the cut end towards the center support. It is recommended to cut the horizontal rail between two of the mounting slots in the rail.

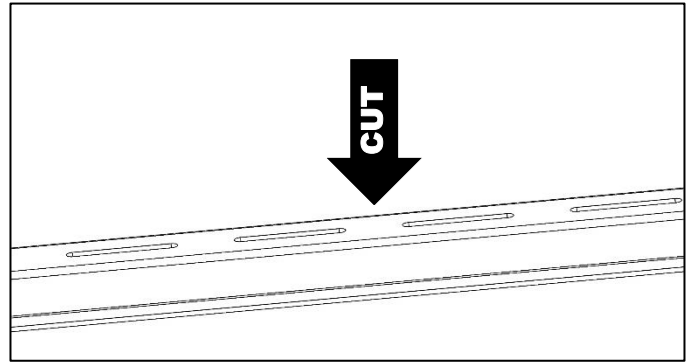

- Obtain two mounting brackets from mounting hardware kit.
- Hold one mounting bracket against the center of rear roof support beam. Be sure the mounting bracket is level to the roof support beam. Mark two mounting-hole locations on the roof support beam.

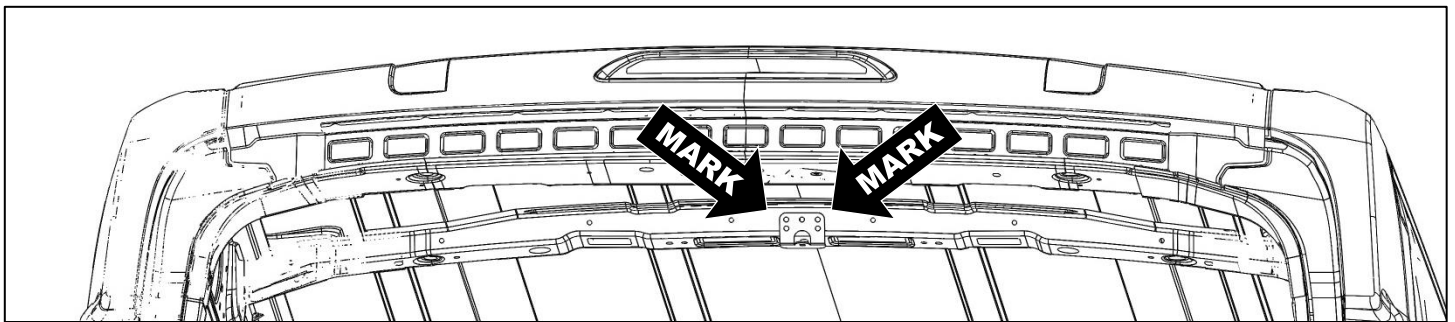

- Hold second mounting bracket against the center of forward roof support beam. Be sure the mounting bracket is level to the roof support beam. Mark mounting hole locations on the roof support beam.

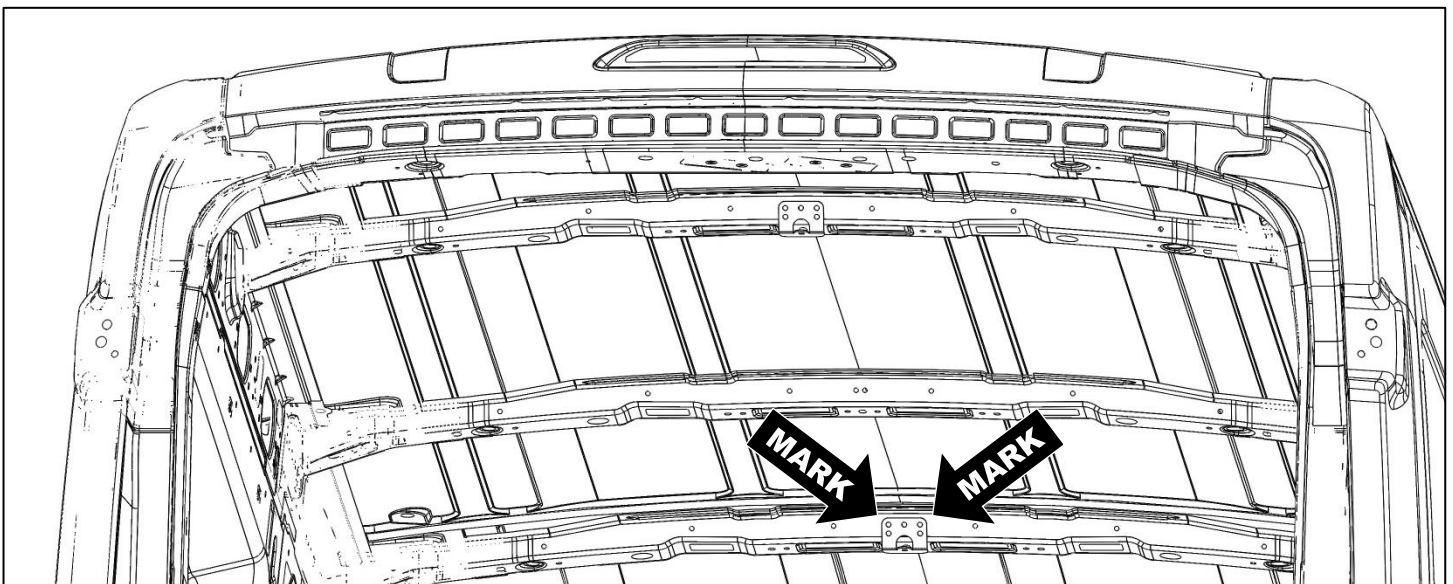

- Per the Plus Nut Installation instructions above, drill holes and install plus nuts at the locations marked on the roof support beams.
- Using two 1/4" x 3/4" hex head bolts and two 1/4" lock washers for each mounting bracket location, install mounting brackets to plus nuts so the bolts are just barely snug.
- Using two 1/4" x 3/4" carriage bolts, two 1/4" fender washers, and two 1/4" lock nuts, attach rail assembly to installed mounting brackets. Tighten lock nuts until horizontal rail is just barely snug against mounting bracket.

- At each of the remaining roof support beams, using a 1/4" x 3/4" carriage bolts, a 1/4" fender washer, and a 1/4" lock nut, loosely attach a mounting bracket to the rail assembly.
- Mark the locations through the mounting bracket holes onto the roof support beam.

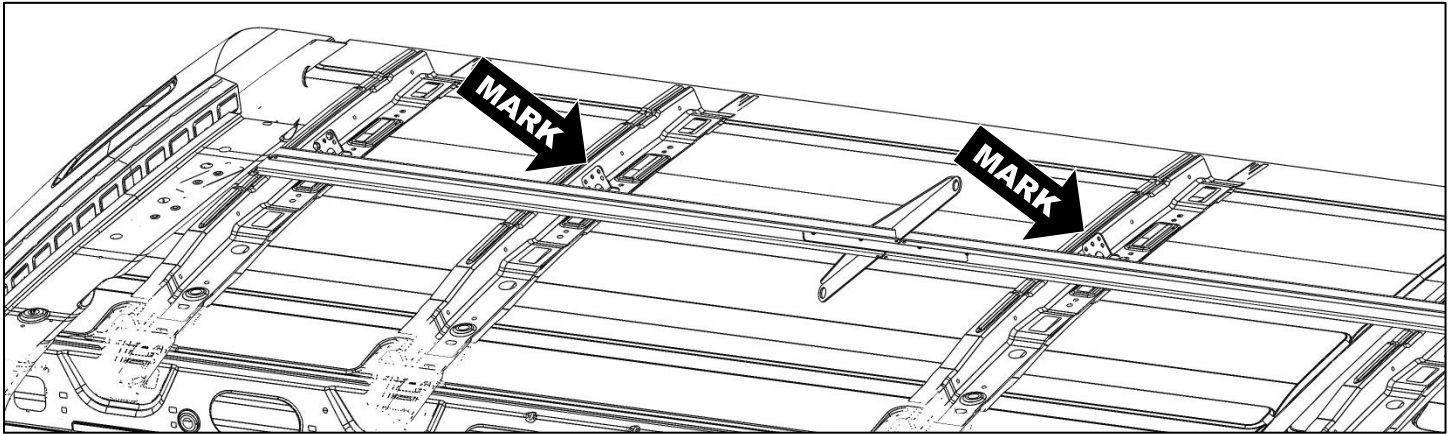

- Make a mark on rail 11" from the rear of van interior ceiling. This mark will be needed during assembly.

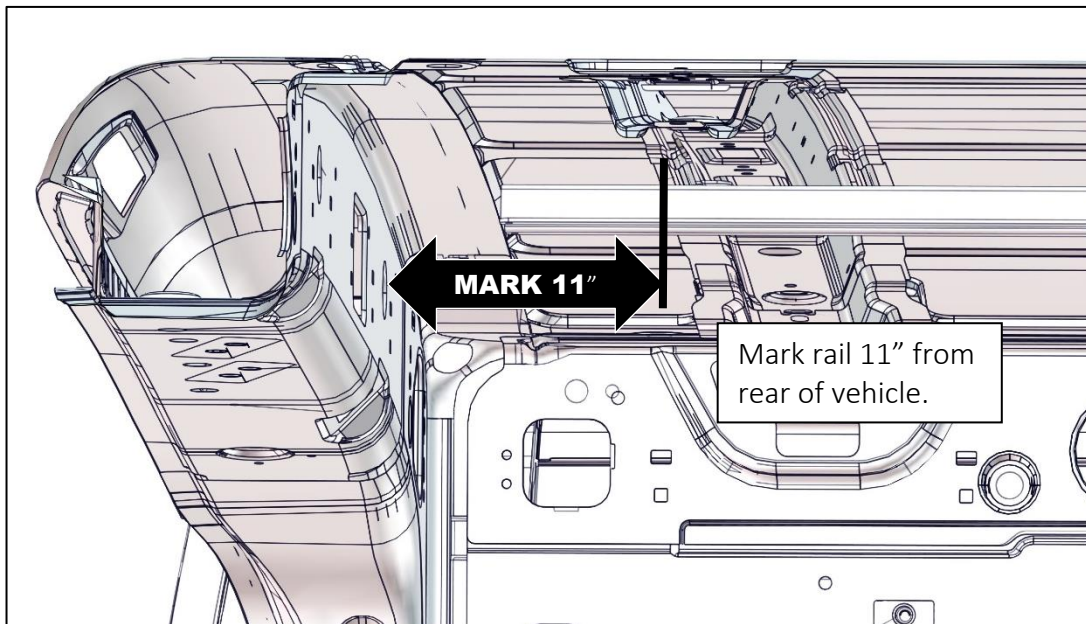

- Keep the front and rear mounting brackets attached to the roof support beams, remove rail assembly and other mounting brackets from roof support beams.
- Per the Plus Nut Installation instructions above, drill holes and install plus nuts at the locations marked on the roof support beams.
- Barely snugly install the mounting brackets to the roof support beams.



## Step 2 – Ladder Catch Assembly

- Using two 1/4" x 3/4" carriage bolts and two 1/4" lock nuts per each clamping bracket, loosely attach clamping brackets to top of rear support bracket. Be sure short flange on each clamping bracket is pointing downward and away from center of rear support bracket.
- Using two 1/4" x 3/4" carriage bolts and two 1/4" lock nuts, attach fixed-end ladder catch to rear support bracket. Tighten nuts until just barely snug. Carriage bolt heads should be towards front of catch.

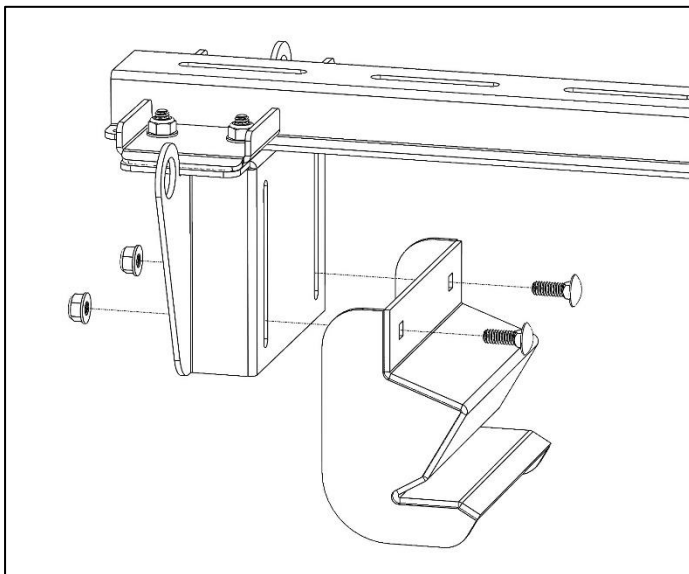
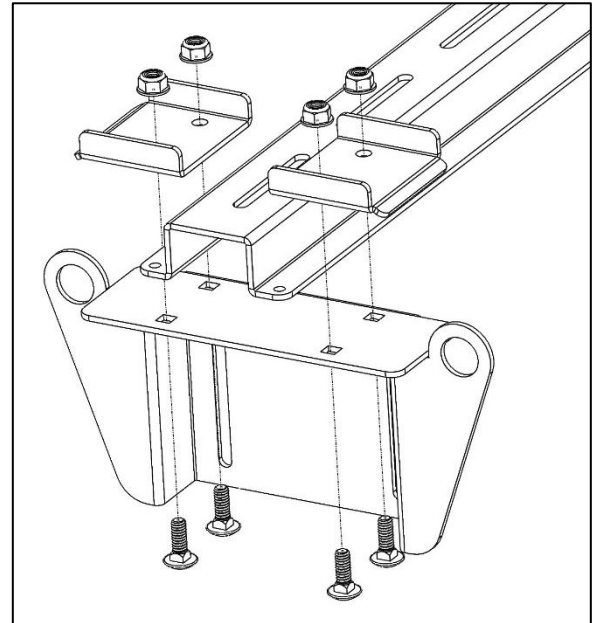

- Slide assembly along rail until forward end of clamping bracket is aligned with 11" distance mark made on rail in previous step. Most stepladders require 11" clearance between bottom of first step and rear of van ceiling and/or rear doors.
- Tighten nuts on clamping brackets until ladder catch assembly is securely fastened in place.

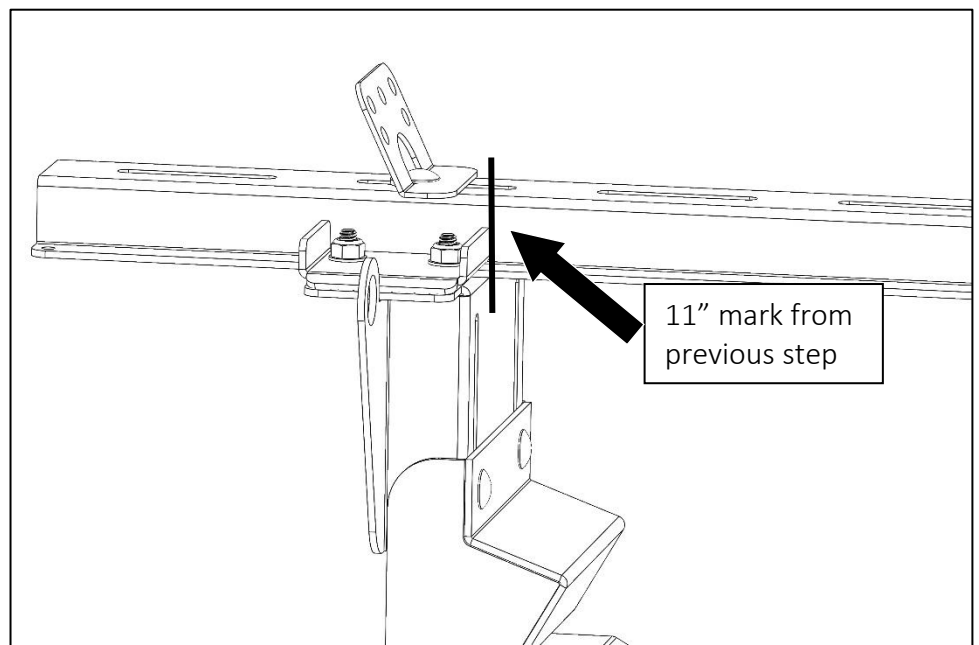

- Insert a snap bushing into each side of rear support bracket with round face towards rear of vehicle.

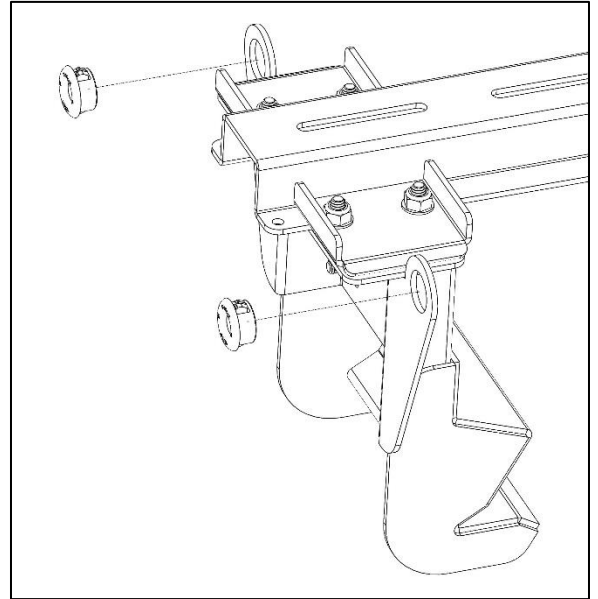

### Step 3 – Mounting the Rail

- Insert a snap bushing into each side of center support with round face towards front of vehicle.

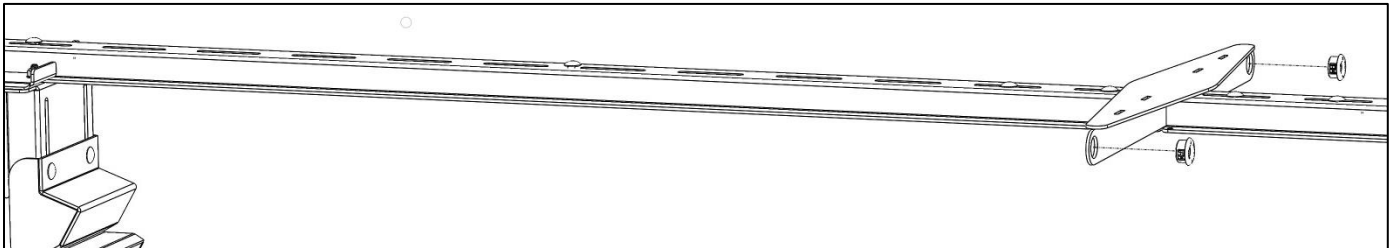

- Lift rail assembly, with ladder catch assembly attached, to roof mounting locations.
- Using two 1/4" x 3/4" hex head bolts and two lock washers for each mounting bracket location, install mounting brackets to previously installed plus nuts. DO NOT over tighten.
- Tighten all nuts to mounting bracket carriage bolts.

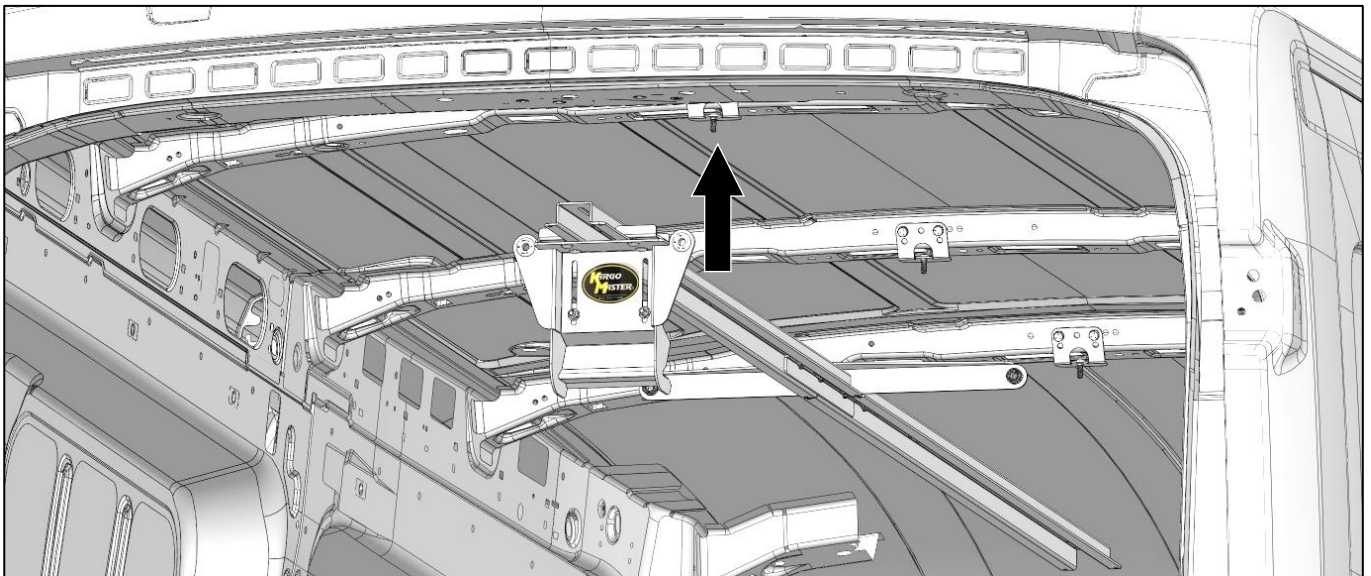

### Step 4 – Sliding Pan Assembly

- Using three 1/4" x 1-1/4" button head screws and three 1/4" lock nuts on each side, attach lower slider plate, slider blocks, and upper slider plates to the top of the sliding bracket. Snugly tighten lock nuts. DO NOT overtighten lock nuts.
- Using two 1/4" x 3/4" carriage bolts and two 1/4" lock nuts, attach sliding ladder hook to sliding bracket. Carriage bolt heads should be towards the pan of the sliding ladder hook. Tighten nuts until just barely snug.

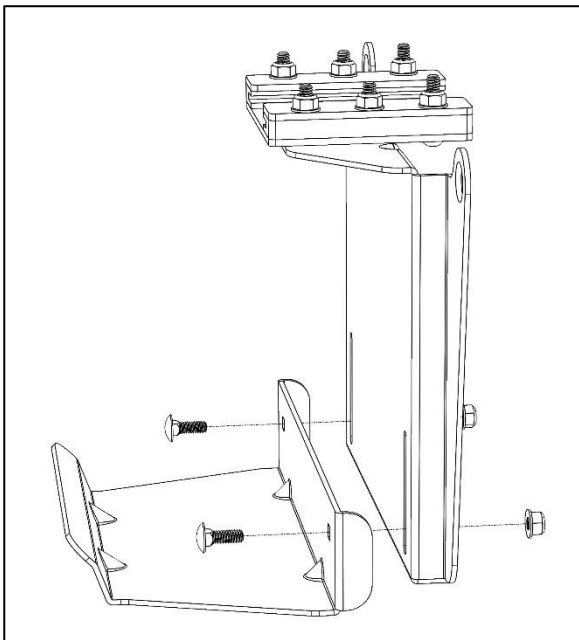
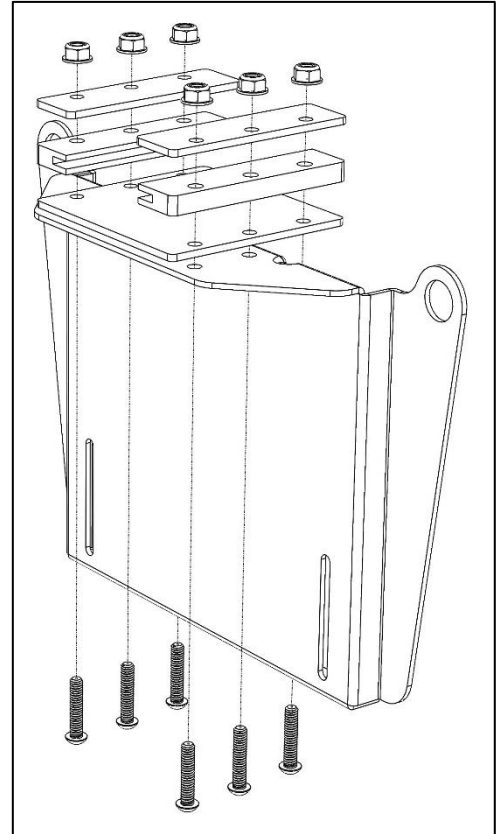

- With hook pointed towards rear, slide slots in sliding hook assembly over rail flanges at forward end of rail assembly.

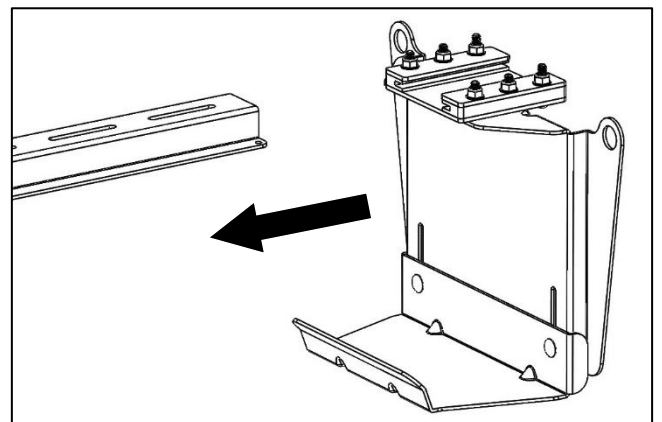

- Insert a snap bushing into each side of sliding bracket with round face towards front of vehicle.

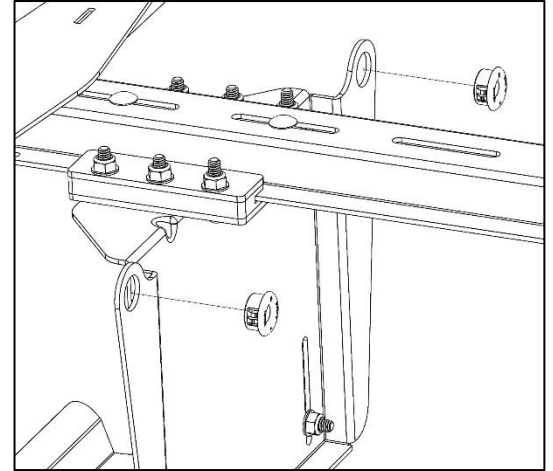

- Install 10-24 x 3/8" socket cap screw and 10-24 lock nut in hole at end of rail behind sliding bracket assembly.



The 10-24 x 3/8" socket cap screw and 10-24 lock nut are safety stops and must remain in place at all times during transport and use.

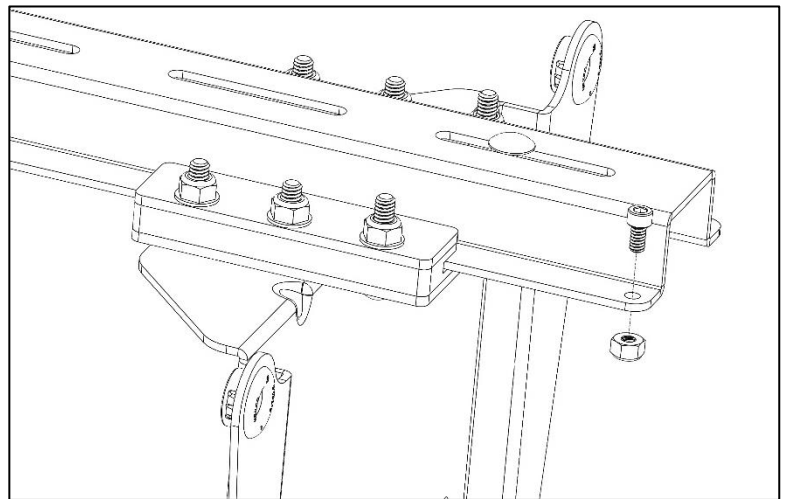

### Step 4 – Bungee Assembly

- If ladder rack will be used only with 6 ft stepladder, cutting the bungee cord is recommended. It is recommended to mark the appropriate length on the bungee cord with tape, and only cut the bungee after the bungee cord has been strung through the ladder rack. The following are the recommended bungee cord lengths per ladder size of the supplied bungee cord.

Ladder Size	Bungee Cord Cut Length
8 ft	10 ft
6 ft	8 ft 4 in.

- Insert end of bungee cord into smaller hole on bungee ball and out larger hole on bungee ball.
- Tie a knot into end of bungee cord.
- Pull on bungee cord until knot snaps into larger hole on bungee ball.

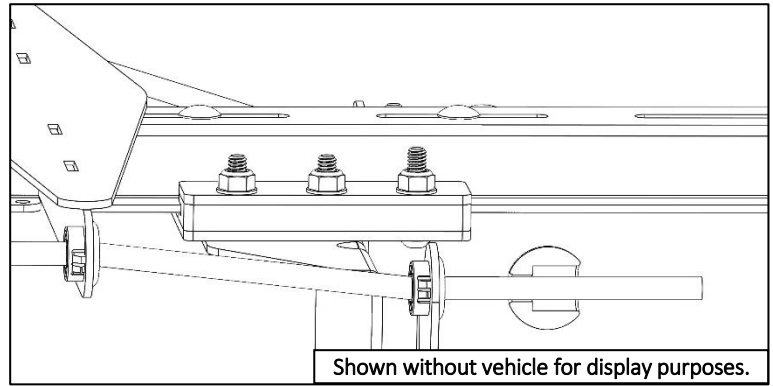

- Thread bungee cord through snap bushings on one side of ladder rack and then back through opposite side snap bushings.

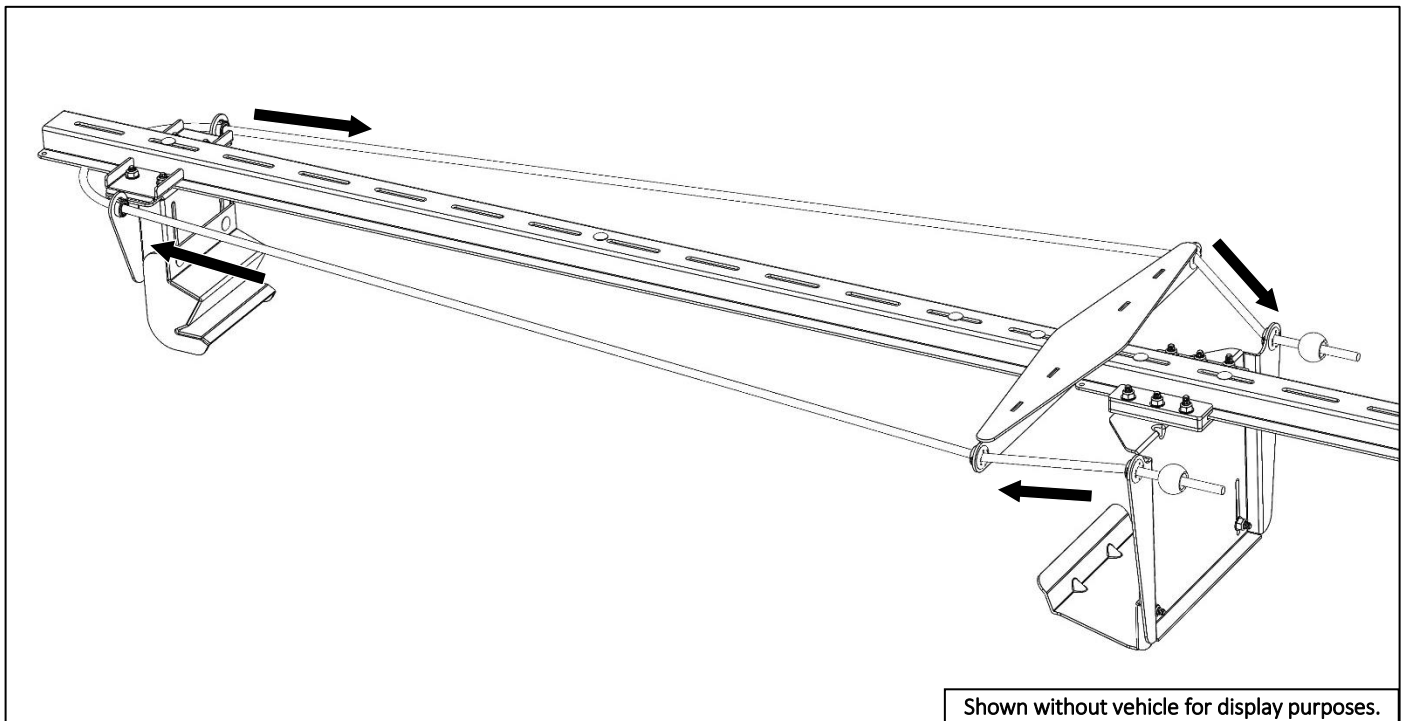

- Insert bungee cord into small hole and out larger hole in second bungee ball.
- Tie a knot in the bungee cord a few inches either before the end of the bungee cord or before the tape marker.
- Pull on bungee cord until knot snaps into larger hole on bungee ball.
- If cutting the bungee cord, cut bungee cord per Bungee Cord Cutting Guidelines above.
- Tighten all hardware.

MAKE SURE ALL HARDWARE IS TIGHT

INSTALLATION IS NOW COMPLETE



## Use Instructions

- Position ladder with thicker front ladder section downward and top of ladder towards front of vehicle.
- Set top of ladder onto sliding ladder hook.
- Push ladder forward and upward.
- Lock ladder into ladder catch assembly.



Always verify that ladder is tightly secure in ladder rack. If ladder is mounted and still loosely secured, bungee cord length may need to be reduced.



If bungee cord is damaged or decaying in any way, replace bungee cord immediately.

