

KARGO MASTER®

WE PUT EVERYTHING WITHIN REACH.

40240 Parts List

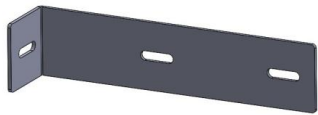

Front Bracket

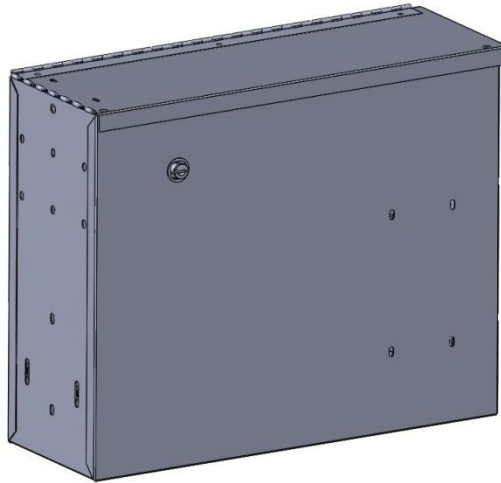

Main Assembly

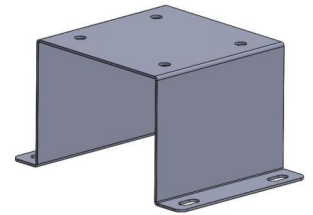

Rear Bracket

40240 Hardware List

(A)
1/4"-20 x .875" Hex Bolt
QTY: 5



(B)
1/4" Flat Washer
QTY: 8



(C)
1/4" - 20 Nyloc
QTY: 3



(D)
5/16" x 1.25" Self Tap Screw
QTY: 4



(E)
5/16" Flat Washer
QTY: 4



(F)
5/16" Split Lock Washer
QTY: 4



(G)
1/4" Split Lock Washer
QTY: 2



Installation Instructions for Ford Transit

Step 1

Bolt bottom bracket to main assembly through the rear holes as shown. Use two 1/4" x 7/8" hex bolt, two 1/4" lock washers and two 1/4" flat washers.

*SNUG TIGHTEN

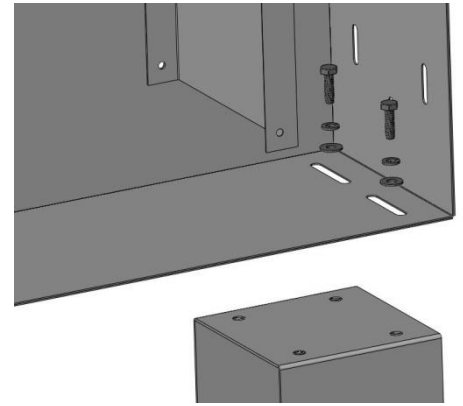

Step 2

Bolt the front bracket to the front of the main assembly using two 1/4" x 7/8" hex bolt, four 1/4" flat washers and two 1/4" nylock nuts.

*SNUG TIGHTEN

** We recommend having bracket all the way towards the bottom of the slots.

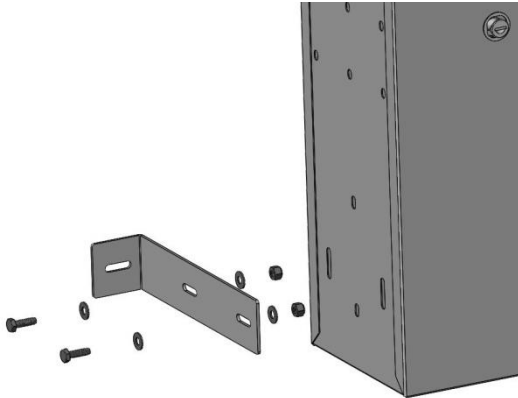

Step 3

Place main assembly with mounting brackets into van. Put in between seats snug against the passenger side. Be sure to have the rear support bracket past the rear of the rib in the floor.

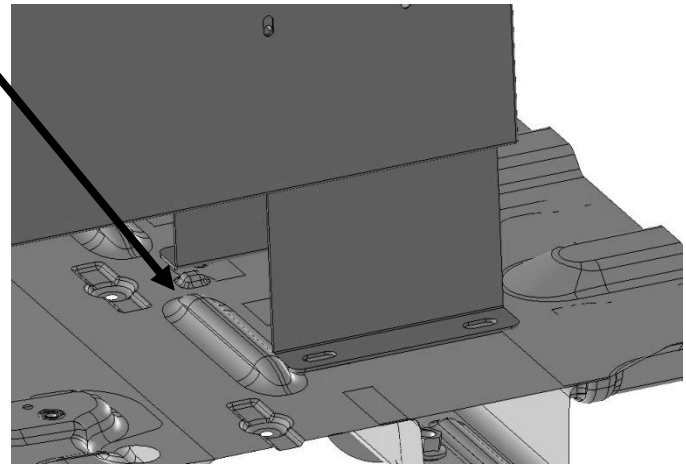
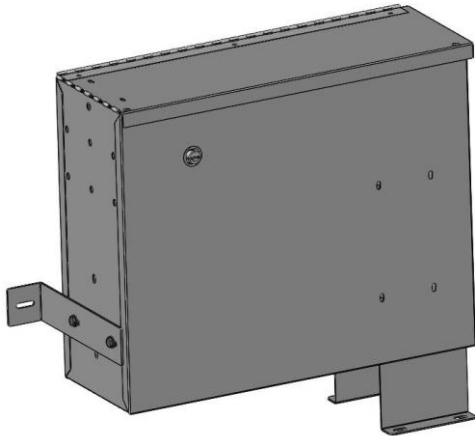

Step 4

Mark the slots in the rear bracket onto the mat or floor. On the side of the seat pedestal, mark the slot in the front bracket.

Remove assembly with brackets

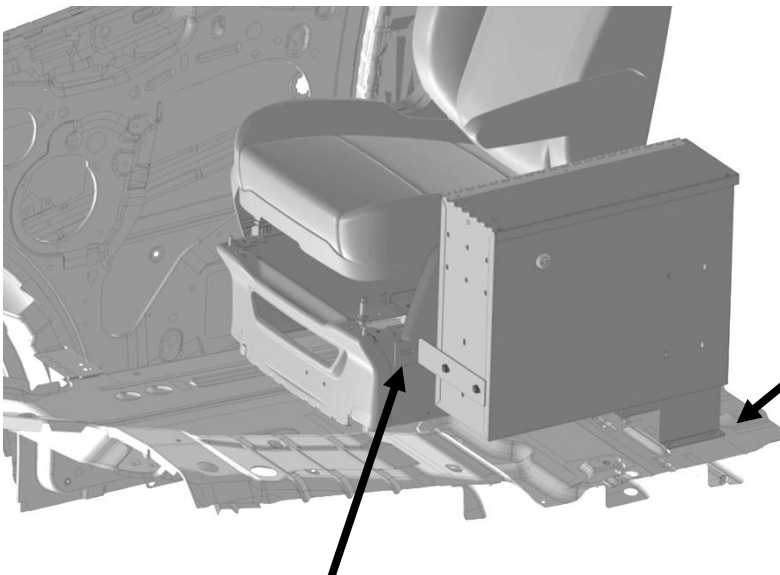

Step 5

Remove rear support bracket from main assembly.
Return to van, Place rear support bracket where you previously marked.
Secure to floor using four 5/16" x 1.25" self tapping screws with flat washers and lock washers.

Step 6

If desired, you can drill a clearance hole for a 1/4" bolt into seat pedestal where previously marked. Or you can wait and drill once the main assembly is placed back into van.

Step 7

Place main assembly with front bracket back into van and bolt to previously installed rear support using two 1/4" x 7/8" hex bolt, two 1/4" lock washers and two 1/4" flat washers.

***SNUG TIGHTEN**

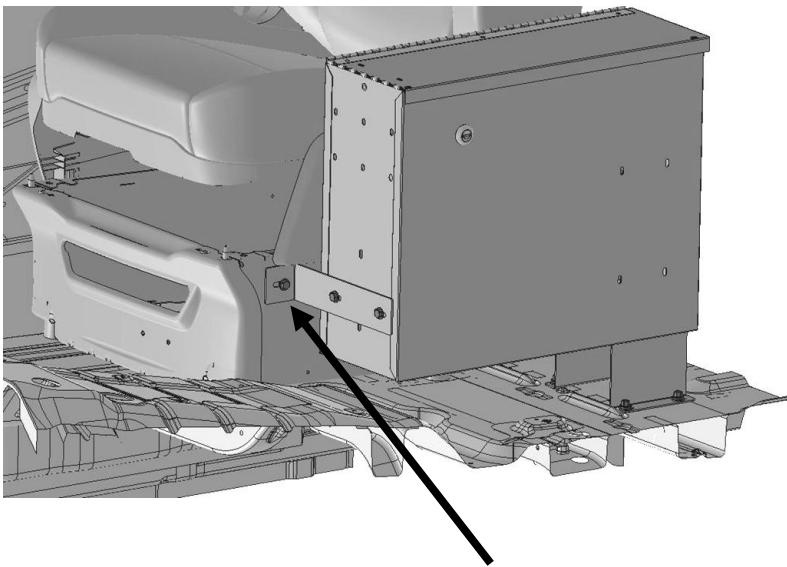
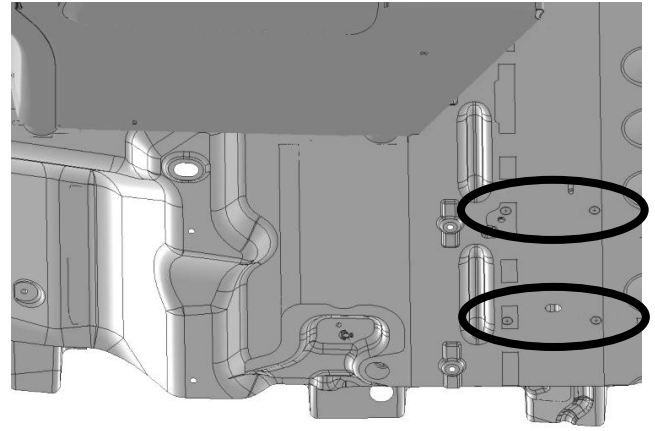

Step 8

If hole is not drilled in seat pedestal mount, align bracket and do so now.

Bolt front bracket to seat pedestal mount using a 1/4" x 7/8" hex bolt, two 1/4" flat washers and a 1/4" nylock nut.

Step 9

Align and square the driver data file. Go back and **TIGHTEN** all bolts.
Your installation is now complete.