

KARGO MASTER®

WE PUT EVERYTHING WITHIN REACH.

Instruction Guide

40221

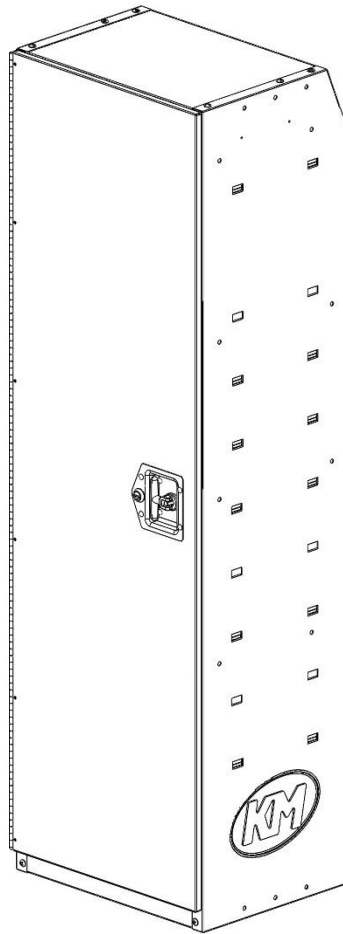

PLEASE READ ALL INSTRUCTIONS AND WARNINGS PRIOR TO ASSEMBLING, INSTALLING, AND USING THIS PRODUCT.

Warning



Always check for wires, fuel tanks and lines, brake lines and other important vehicle functionality items prior to drilling and installing all products.

Tools Needed

Phillips head #2 screwdriver	7/16 Box wrench
Flat head screwdriver	

Table of Contents

Parts List..... 2

Hardware 3



Assembly Instructions 3

Adjustment Instructions..... 11



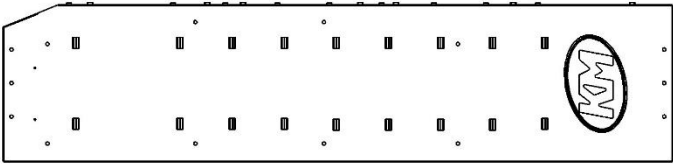
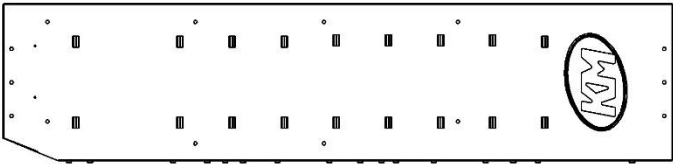
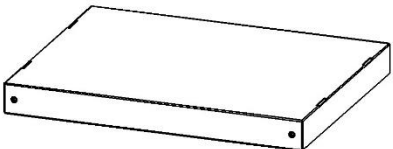
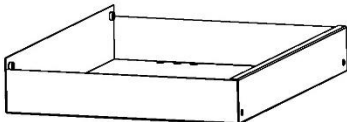
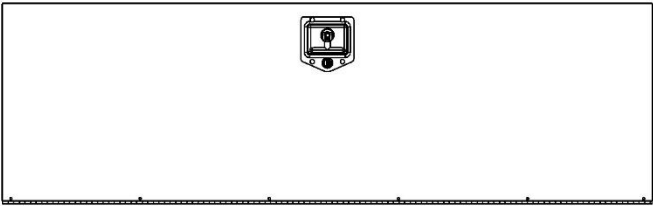
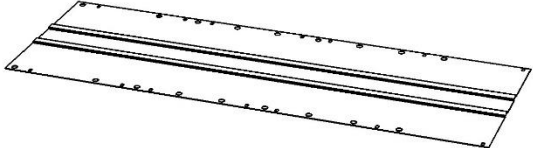

Before You Begin

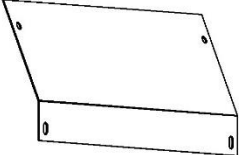
- Read all instructions.
- Locate your mounting locations prior to rack assembly.
- **ENSURE SAFETY WHILE INSTALLING OR DRILLING INTO VEHICLE.**
- **FOLLOW 4861 SHELF MOUNTING KIT INSTALLATION GUIDE INSTALLATION INSTRUCTIONS FOR INSTALLATION INTO VEHICLE.**

Parts List

ITEM NO.	ITEM	PART NUMBER	DESCRIPTION	QTY.
1		100707	60" LOCKER RIGHT SIDE PANEL ASSEMBLY	1
2		100708-R1	60" LOCKER LEFT SIDE PANEL ASSEMBLY	1
3		100557	18" SHELF ASSEMBLY	3
4		100564	LOCKER BOTTOM ASSEMBLY	1
5		100558	LOCKER DOOR ASSY, 60" H X 18" W	1
6		100561	60" LOCKER REAR PANEL	1
7		100565	LOCKER TOP PANEL ASSY, 18" W	1
8		100706	LOCKER TOP REAR PANEL	1
9		18-40221	HARDWARE KIT	
11		4861	SHELF MOUNTING KIT	1

Hardware

ITEM	HARDWARE TO SCALE	PART NUMBER	DESCRIPTION	QTY.
1		29161	1/4"-20 X 1/2" PHILLIPS MACHINE SCREW	28
2		0167030	1/4"-20 FLANGED LOCK NUT	10
3		0175424	1/4"-20 X 3/8" PHILLIPS PAN HEAD SEMS SCREW	15
4		90298A848	1/4"-20 X 3/8" ONE WAY SCREW	8

Assembly Instructions

- Ensure appropriate clearance for installing locker.
- Flatten box top and lay out on workbench to protect shelf from scratches during installation.
- Lay left side panel flat on workbench and insert bottom pan into side panel.
- Using two 1/4" x 1/2" machine screws, install the locker bottom assembly to the side panel.

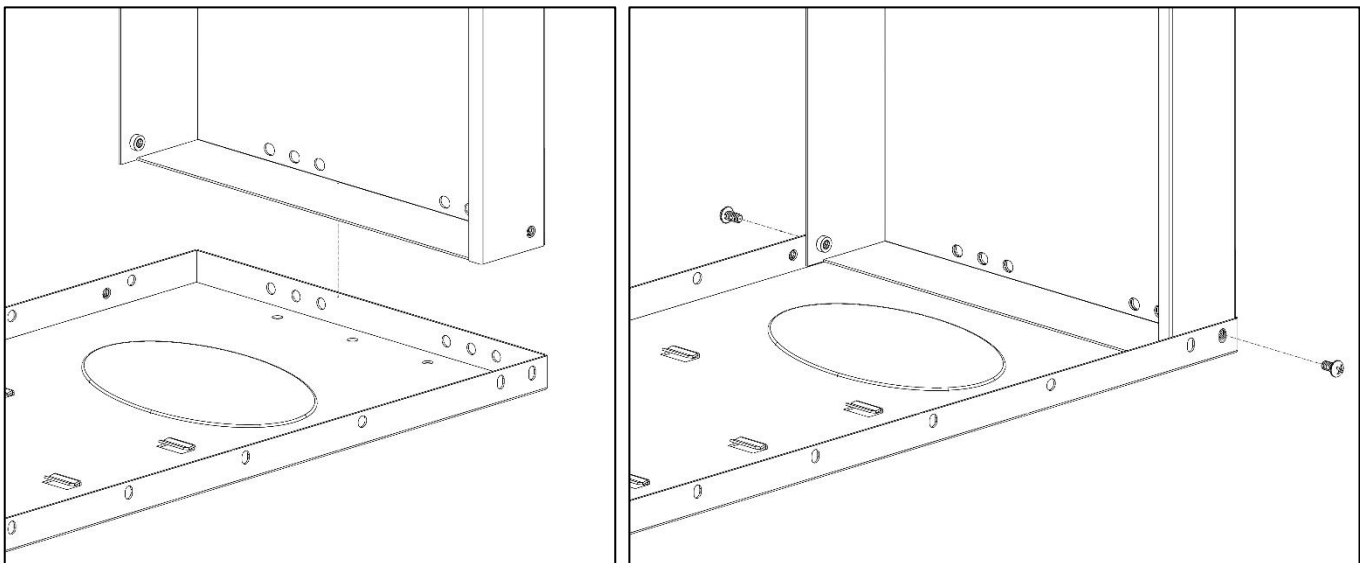

- Shelves can be assembled with flanges pointing up to retain shelf contents, or flanges pointing down to allow the installation of drawer cabinets. Decide which option you want for each shelf before attaching it to the sides. The beveled corner of each Shelf Side is in the back. Each shelf, the front side only has nuts pressed into the shelf flange. Make sure the shelf is oriented properly (pressed-in nuts in front) before attaching.
- Press the shelf down firmly so that it is resting solidly against the side panel and above shelf retainers for lowest desired shelf location.

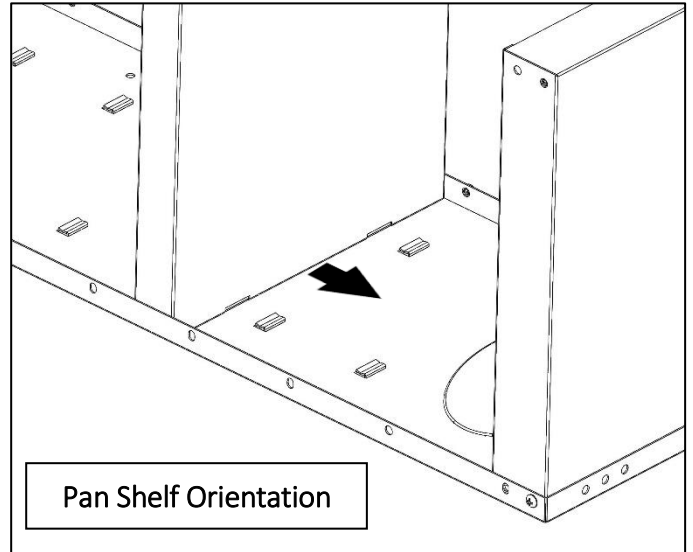
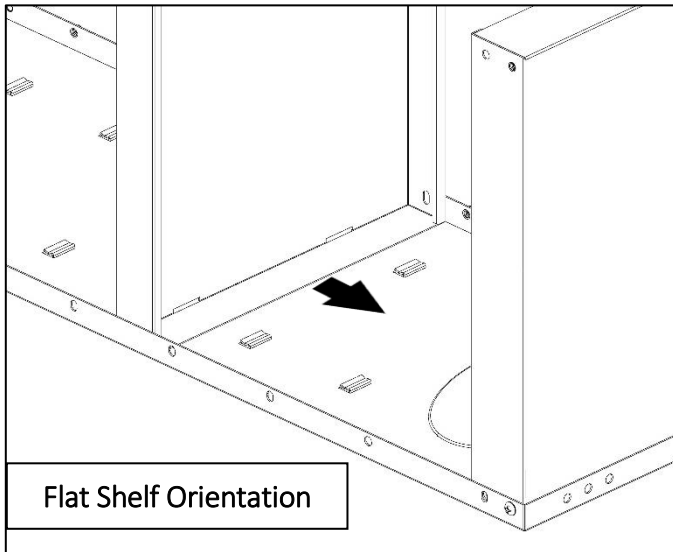

- Slide shelf firmly under and against shelf lances.
- Install one 1/4" x 1/2" machine screw through the front of the side panel into the pressed-in nut on front of shelf.

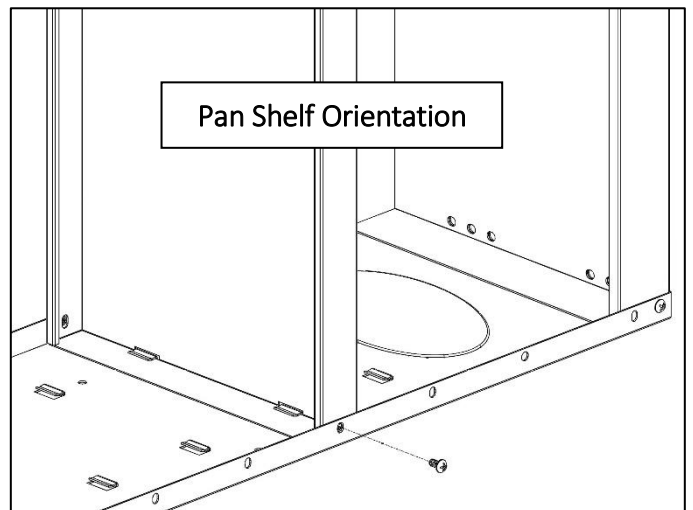
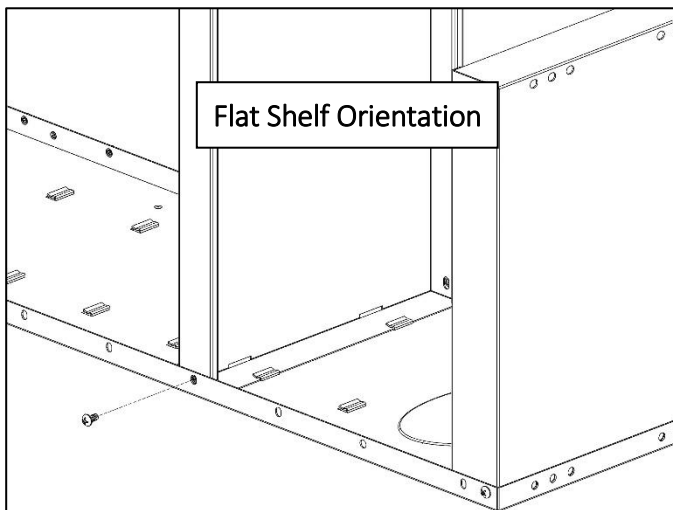

- Install one 1/4" x 1/2" machine screw through the rear of the shelf into the pressed-in nut on the rear of the shelf side.

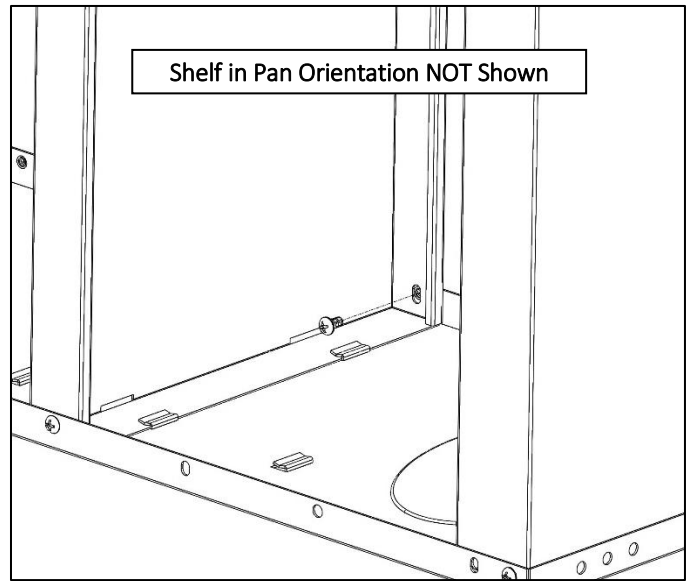

- DO NOT install a shelf in the sixth shelf position from the bottom. A shelf installed in this position will not allow the door to close properly.
- Install remaining shelves

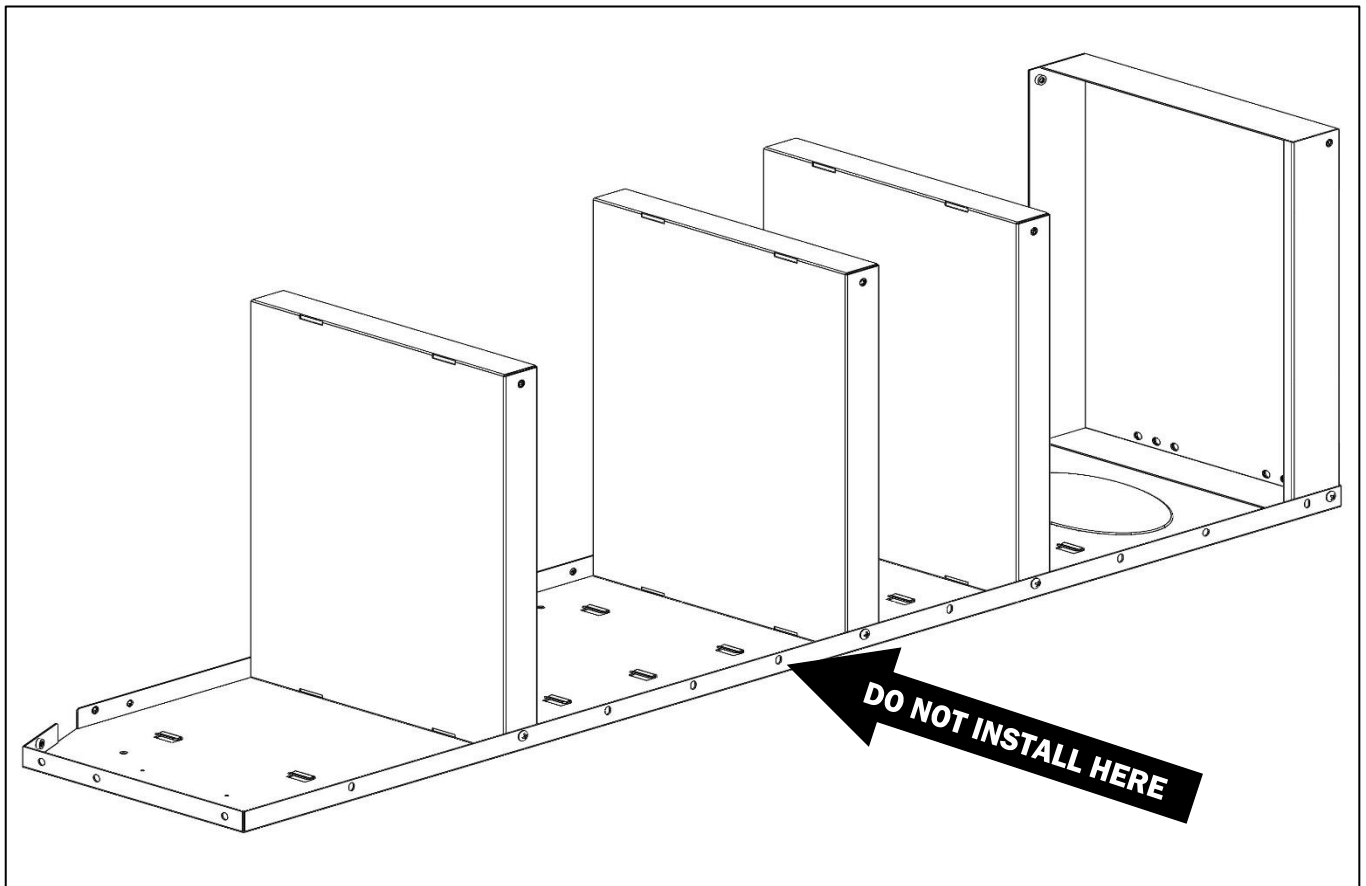

- Install opposite side panel to locker bottom assembly and shelves per previous directions above.

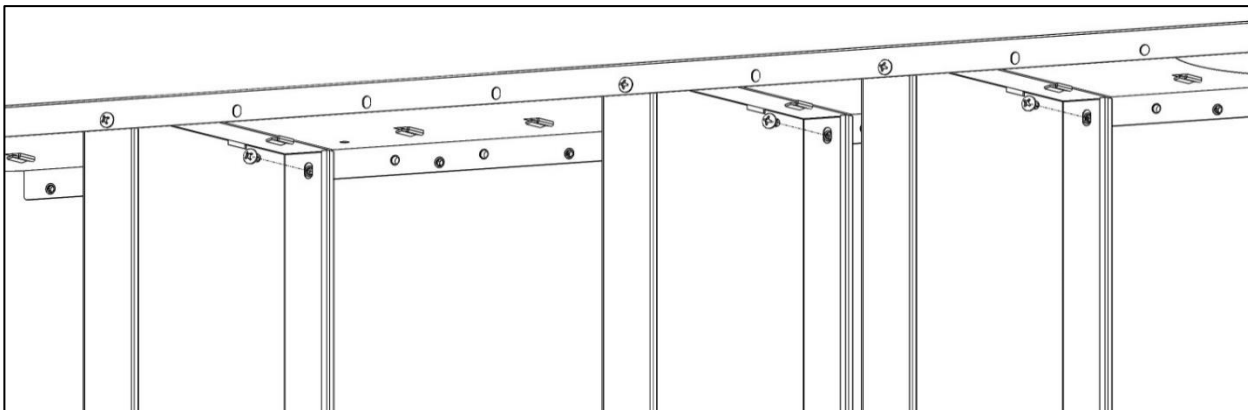
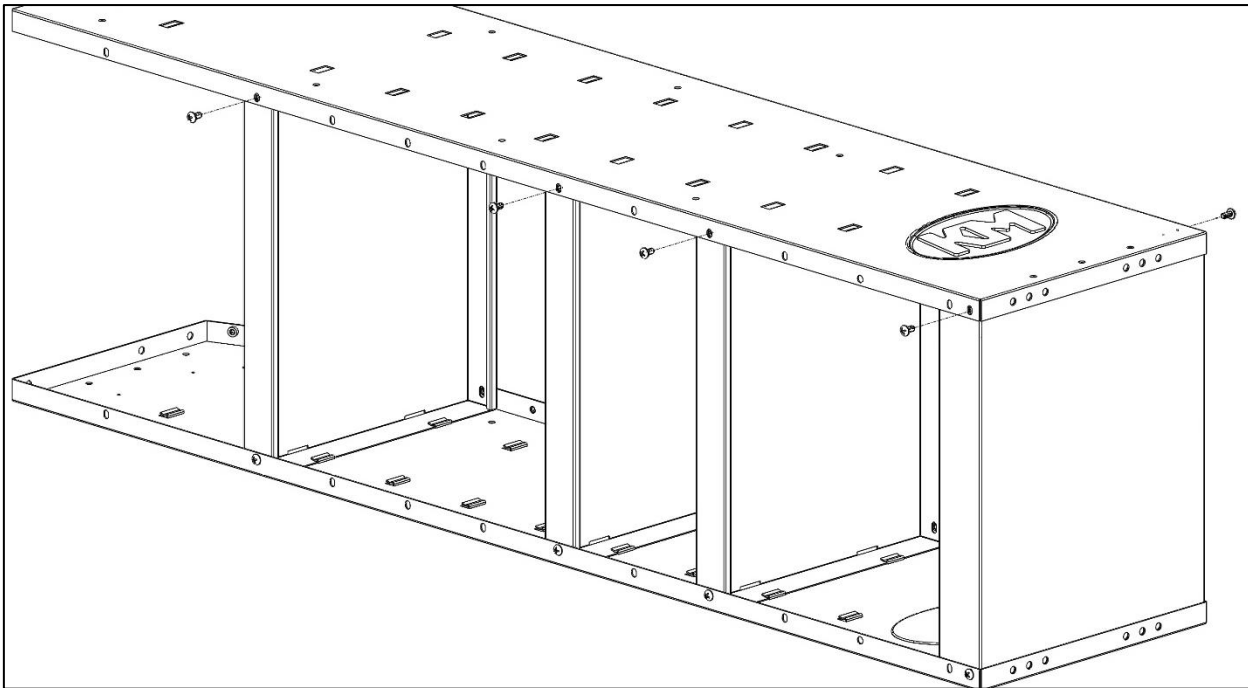
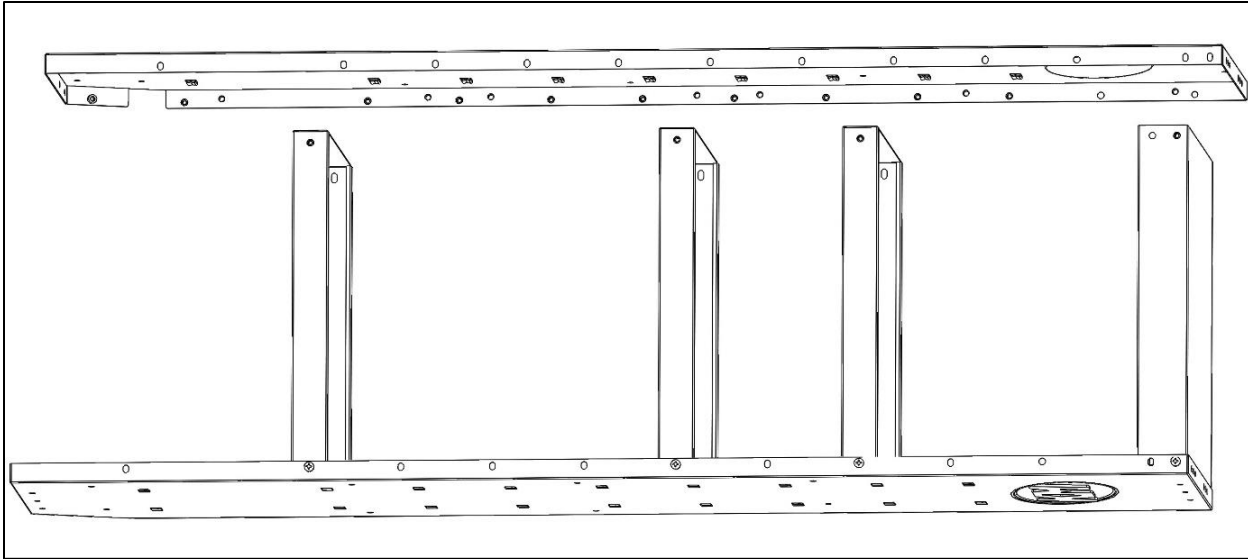

- Making sure the shelves are square to the side panels, install the rear panel using fourteen 1/4" x 3/8" Phillips SEMS screws.

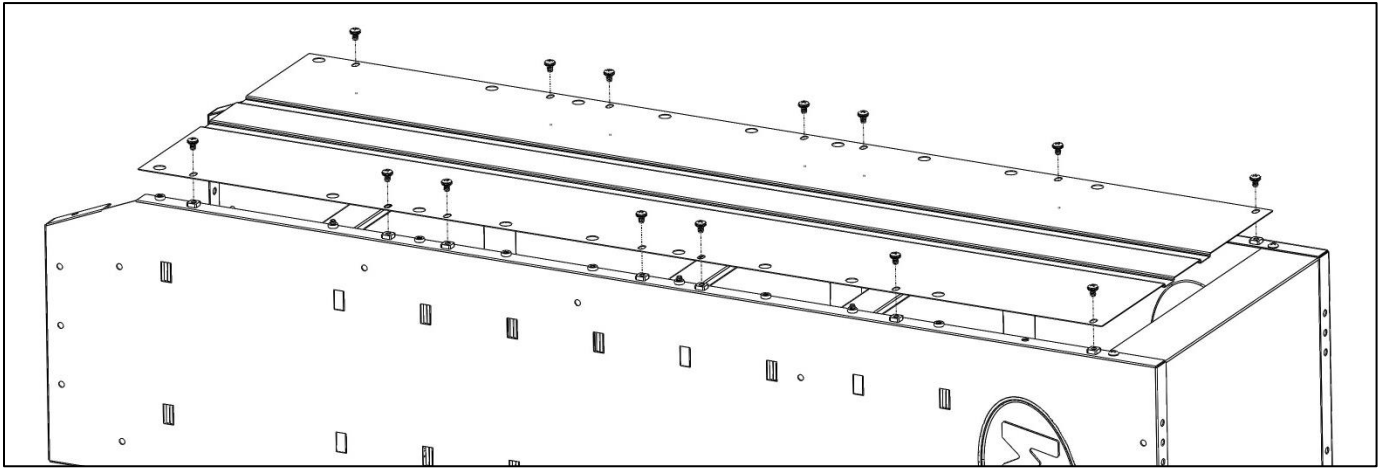

- The door can be installed opening left or opening right. Based upon door clearance, determine which side to install door.

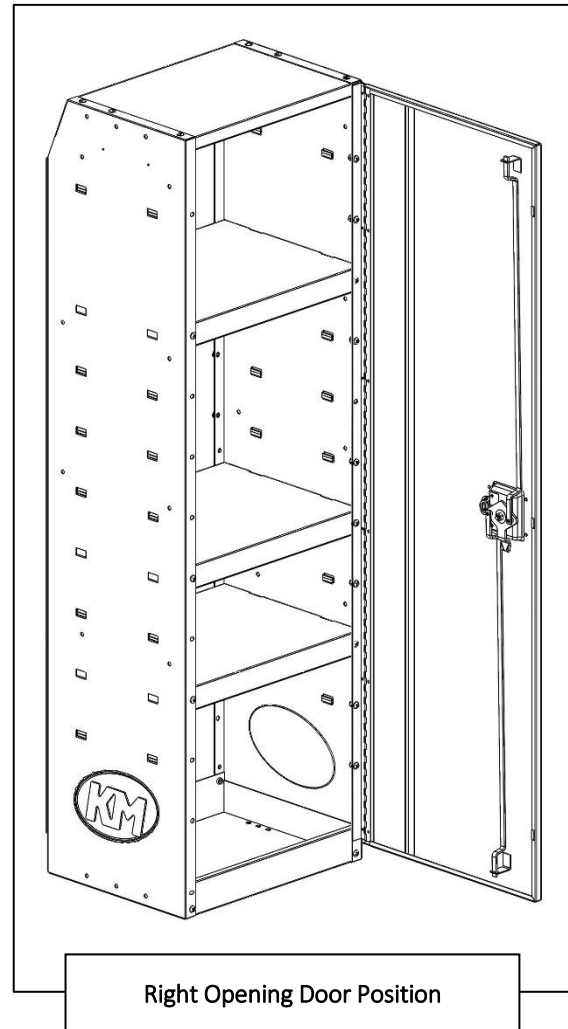
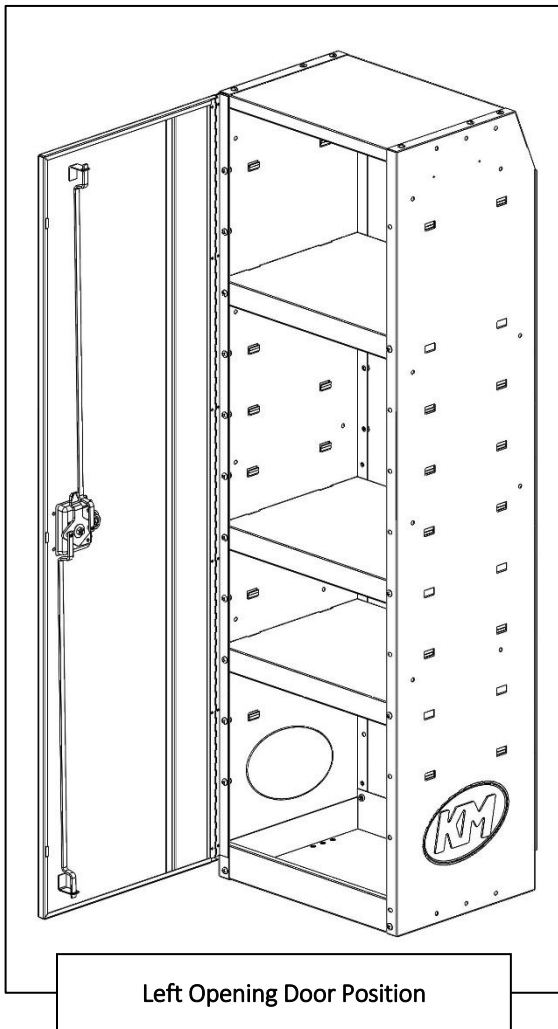

- With locker laying on the side hinge will attach to, remove the 1/4" x 1/2" screw from the front of each shelf.
- Laying the door flat on the workspace, fasten the previously removed 1/4" x 1/2" machine screws through the door hinge into the shelves.

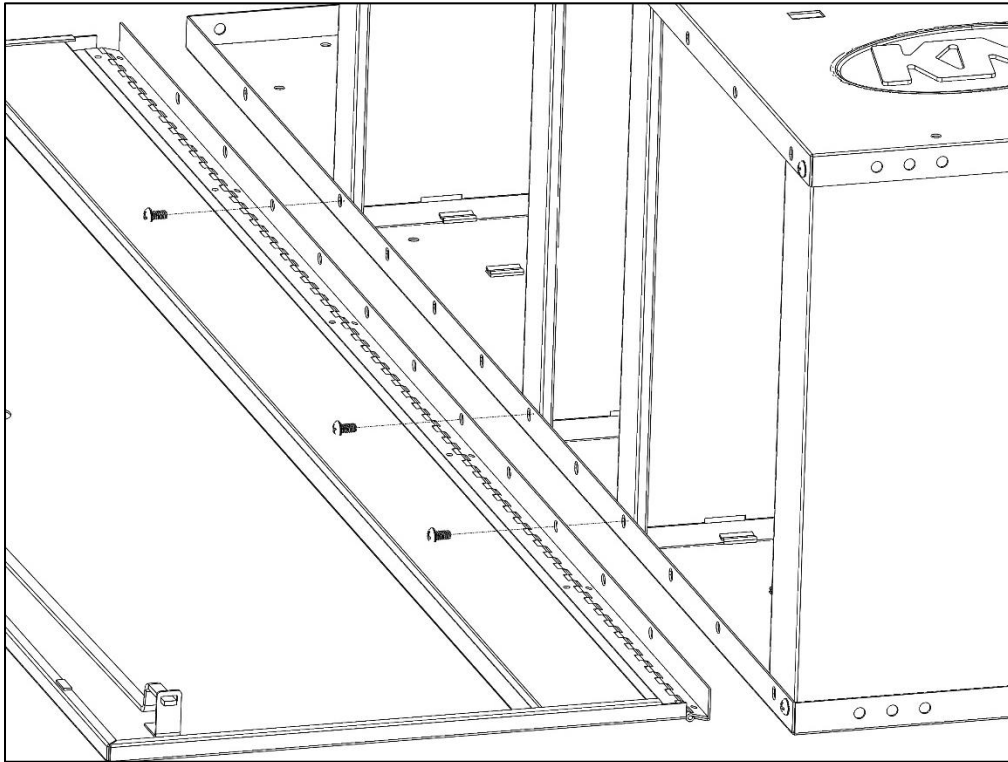

- Using eight 1/4" x 1/2" Phillips machine screws and eight 1/4" flanged lock nuts, install door to side panel.

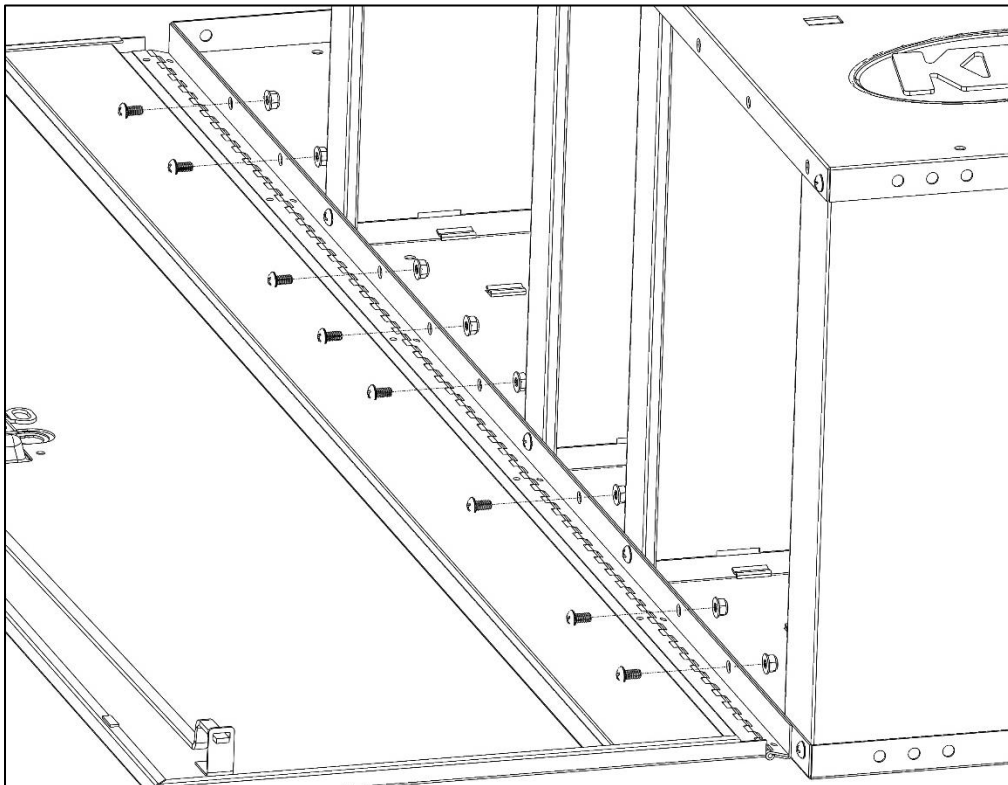

- Install the top panel assembly using six 1/4" x 3/8" one-way screw.

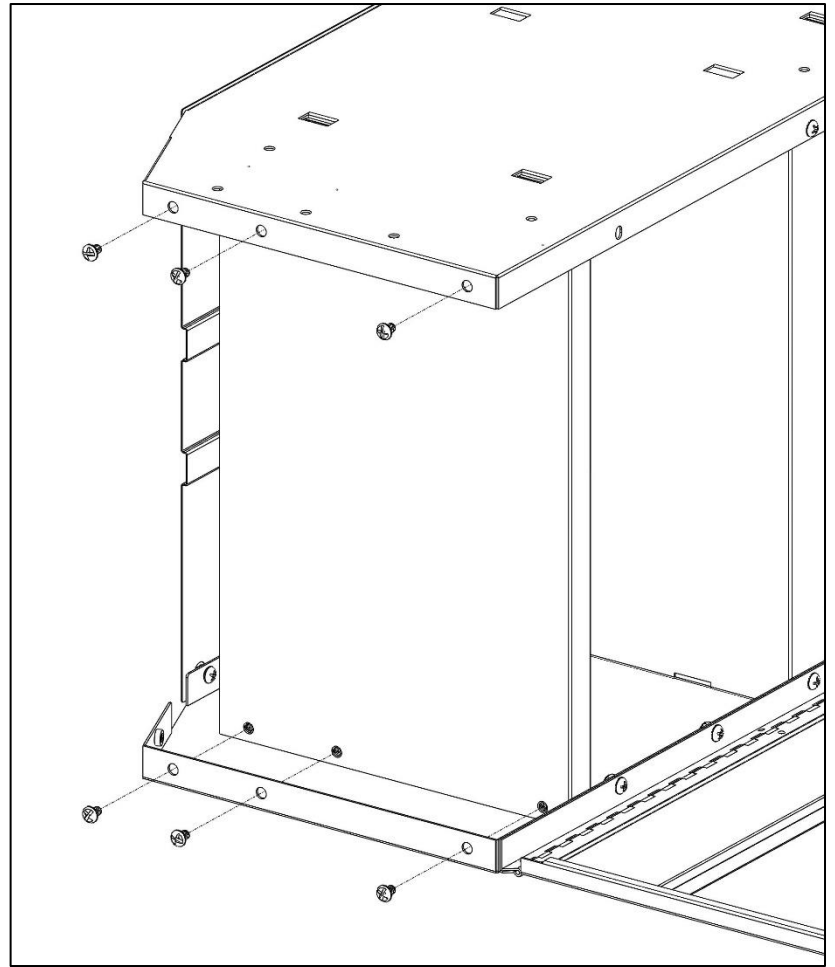

- Slide the rear cover panel inside the shelf-panel rear flanges and outside the top rear shelf-panel flanges.

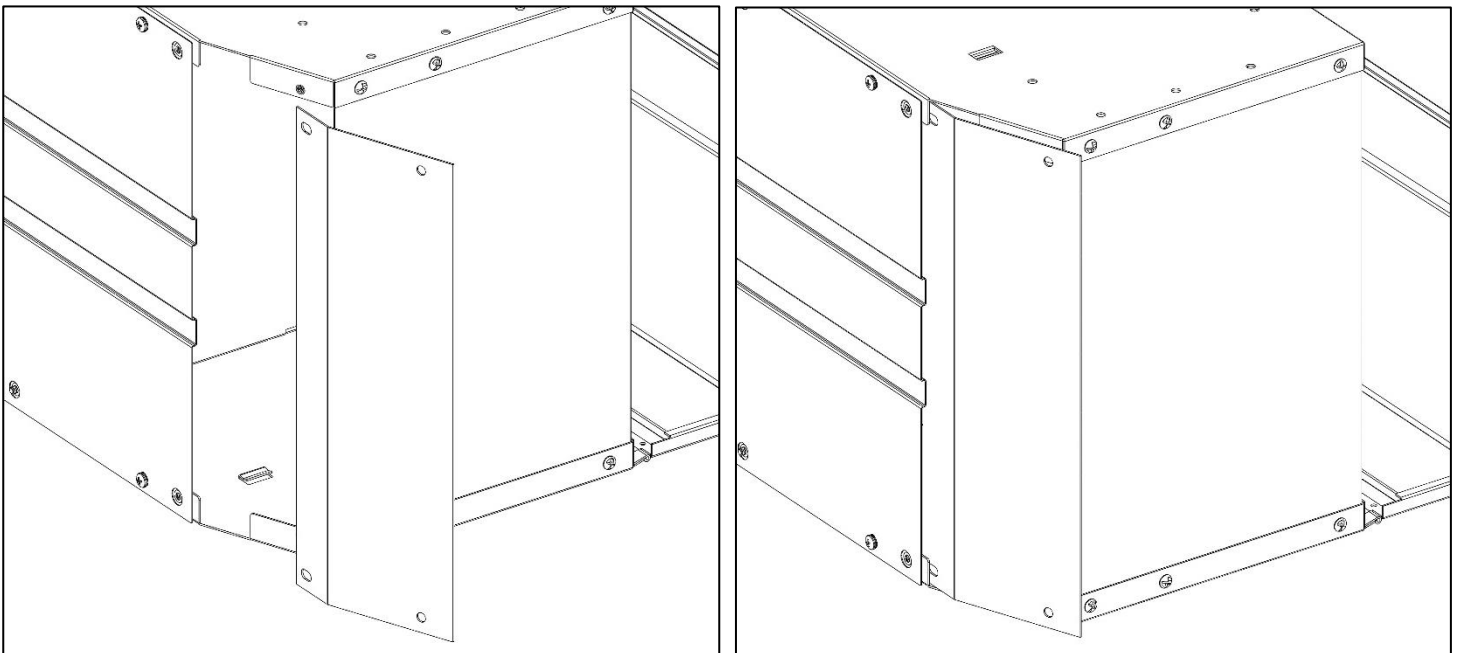

- Install rear panel to the inside of the shelf-panel rear flanges using two 1/4" x 1/2" Phillips machine screws.

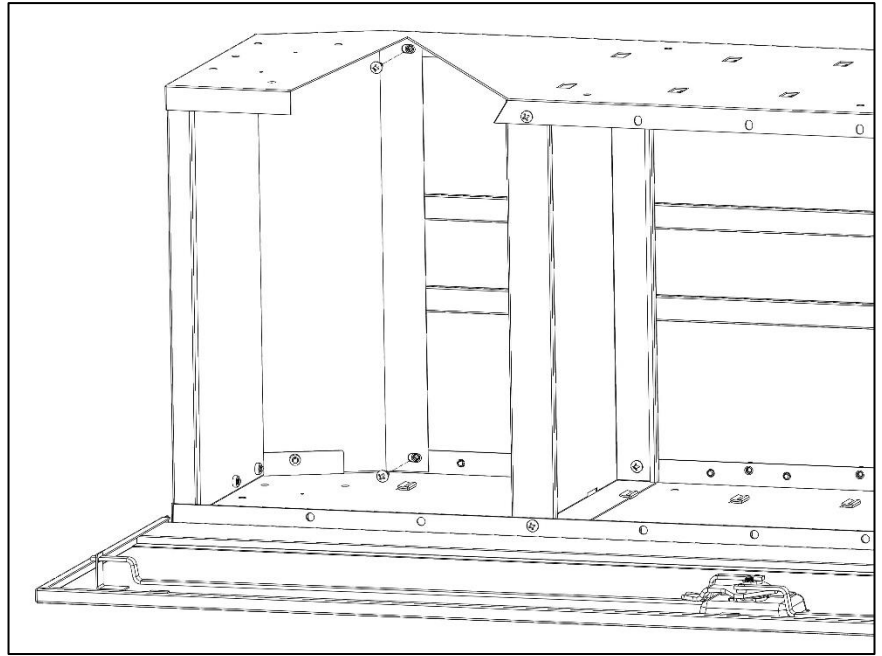

- Install two 1/4" x 3/8" one-way screws through the rear cover panel into the top rear shelf panel flanges.

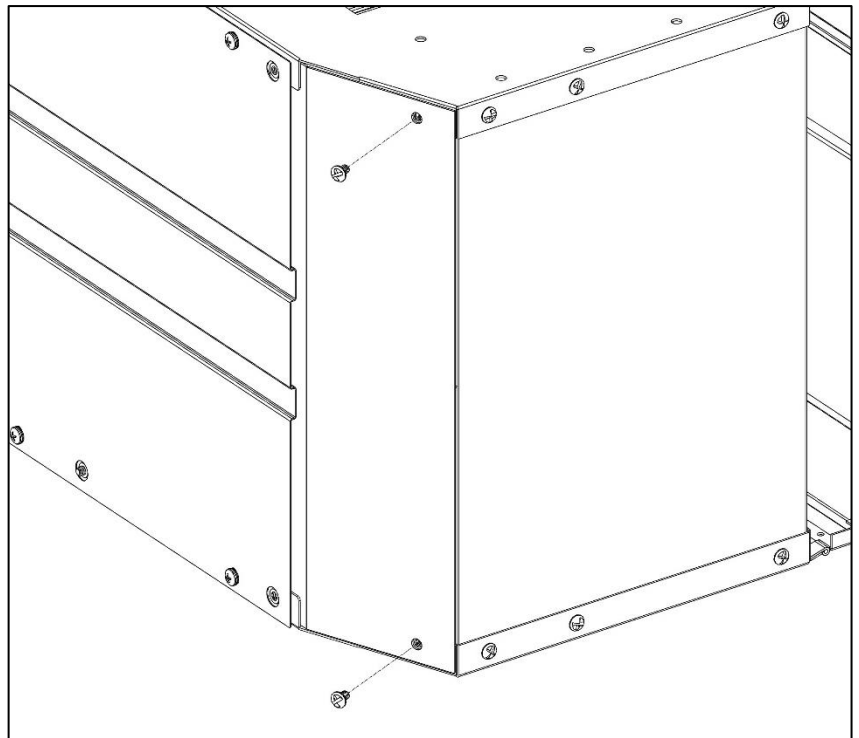

- Install locker per 4861 Shelf Mounting Kit Installation Guide.

MAKE SURE ALL HARDWARE IS TIGHT.

ASSEMBLY IS NOW COMPLETE!

Adjustment Instructions

- If door is out of alignment or drooping, slightly loosen screws and nuts holding door to side panel.
- Shift door up or down depending on desired adjustment.
- Tighten screws and nuts.

