



**WE PUT EVERYTHING WITHIN REACH.**

---

# Instruction Guide

## 31520

---

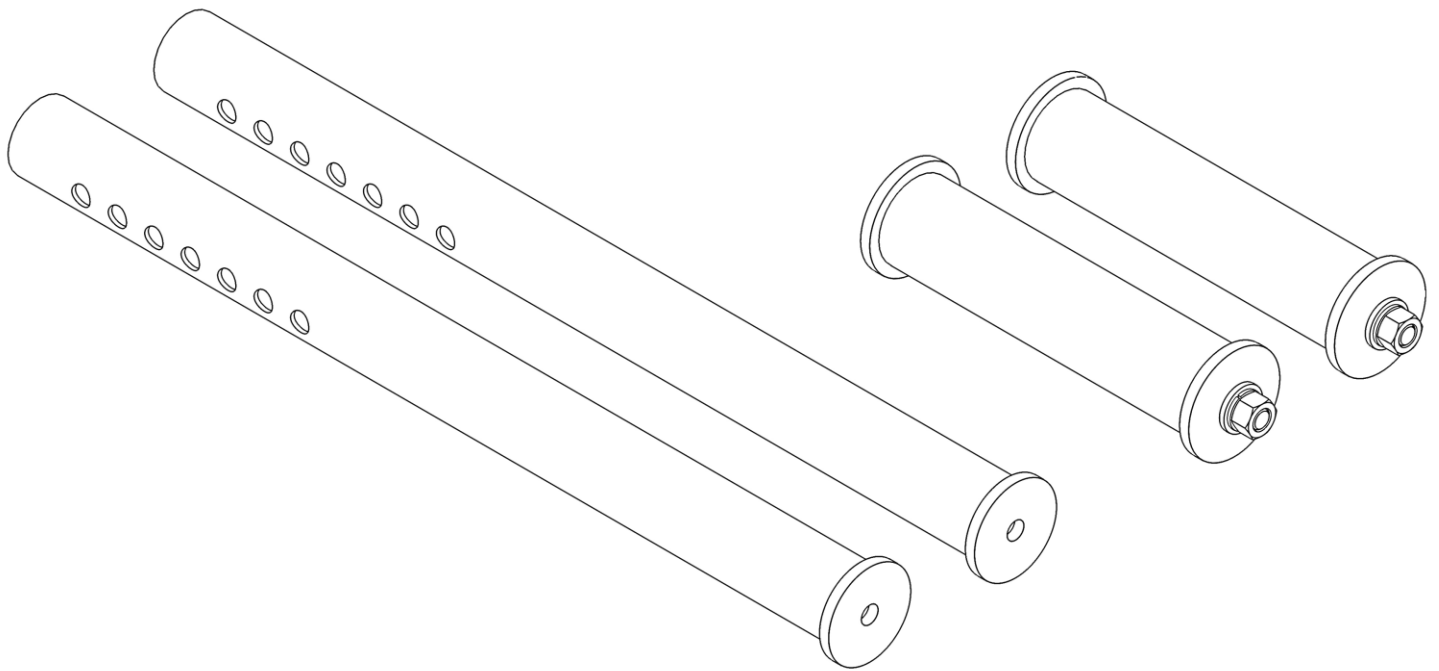

**\*PLEASE READ ALL INSTRUCTIONS AND WARNINGS PRIOR TO ASSEMBLING, INSTALLING, AND USING THIS PRODUCT.\***

**WARNING**



Always check for wires, fuel tanks and lines, brake lines and other important vehicle functionality items prior to drilling and installing all products.



Too much weight will greatly reduce the stability of your vehicle. Kargo Master makes no representation or warranty as to the amount of weight your vehicle can safely carry. For guidance, we recommend that you consult the vehicle manufacturer. At no time should the weight of the vehicle, rack, driver, passengers and cargo loaded on a Kargo Master rack exceed either the Gross Vehicle Weight Ratio (GVWR) or the Gross Axle Weight Ratio (GAWR) as specified by the vehicle manufacturer.



Do not use your rack with the rear cross bar removed. Removal of rear crossbar will affect structural integrity of the rack.



Secure all payloads properly for safe transportation.

**Tools Needed**

Refer to the Tools Needed section of Pro II Service Body Rack Instructions for complete list of tools required to install complete rack.

9/16", 3/4" Sockets and Wrench	7/32", 5/16" Allen Wrenches
11/32, 13/32" Drill Bits	Drill

**Table of Contents**

Parts List..... 2

Hardware ..... 2

Step 1 – Part Replacement ..... 3

Step 2 – Install Front Leg without Support Arms..... 3

Step 3 – Install Rear Leg Extensions..... 3

Step 4 – Install Support Arm to Front Leg..... 4

Step 5 – Install Support Arm to Service Body ..... 5

**Before You Begin**

- Refer to Pro II Service Body Rack Instructions for rack assembly. These instructions compliment those instructions.
- Read all instructions prior to assembling or installing any Kargo Master product.

**Parts List**

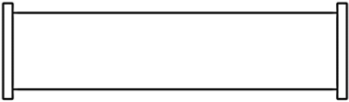
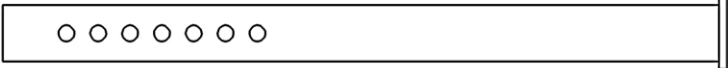
ITEM NO.	ITEM	PART NUMBER	DESCRIPTION	QTY.
1		100569	LEG EXTENSION ASSY, 9"	2
2		100748	SERVICE BODY EXTENDED LEG	2
3		18-31520	HARDWARE KIT	1

**Hardware**

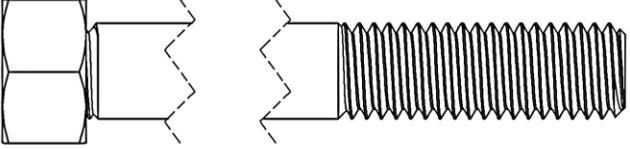
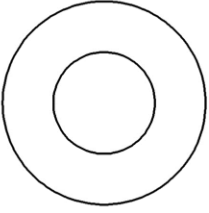
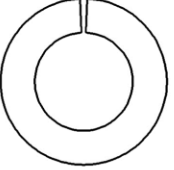
ITEM	HARDWARE TO SCALE	PART NUMBER	DESCRIPTION	QTY.
1		100650	1/2"-13 x 10" HEX BOLT	2
2		11541086	1/2" WASHER	2
3		0171934	5/16" LOCKING WASHER	2

---

**DO NOT EXCEED MANUFACTURERS GVWR OR GAWR AT ANY TIME.**

---

**Step 1 – Part Replacement**

- Replace 3-1/2" leg extensions in 70020 Leg and Bar kit with 9" leg extensions from this kit.
- Replace service body telescoping leg in 70020 Leg and Bar kit with service body extended legs from this kit.

---

**Step 2 – Install Front Leg without Support Arms**

Follow the following instructions in place of Step 4 of *Pro II Service Body Rack Instructions* for installing front leg.

Be sure to read the *Before You Begin* section of of *Pro II Service Body Rack Instructions* and this document before installing front legs.

- Do not install support arms at this time.
- Based upon height of cab and clearance required, insert 9" leg extensions into leg assembly and then insert 1/2" x 3-1/4" bolt into holes through leg assembly.
- Fasten 1/2" washer and 1/2" lock nut to bolt.
- Repeat on opposite side.

---

**Step 3 – Install Rear Leg Extensions**

Install the rear legs and 9" leg extensions the same as you would the rear legs and 3" leg extensions in Step 7 of *Pro II Service Body Rack Instructions* with the following exceptions.

- Using the 1/2" x 10" hex head bolt instead of the 1/2" x 4-1/2" hex head bolt, loosely install the rear foot and the 9" extension to the rear leg.
- Snug tighten but allow for movement.
- Repeat on opposite side.

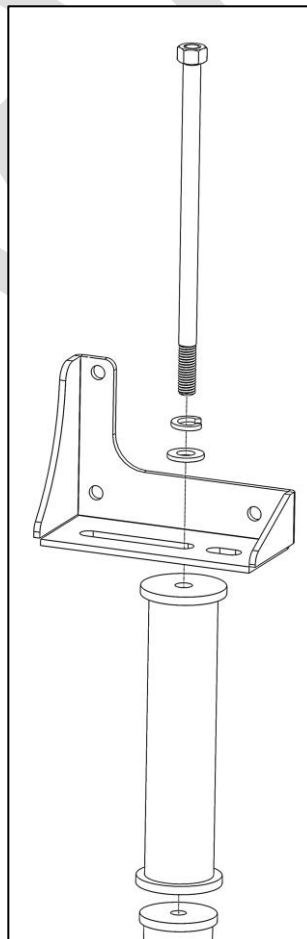
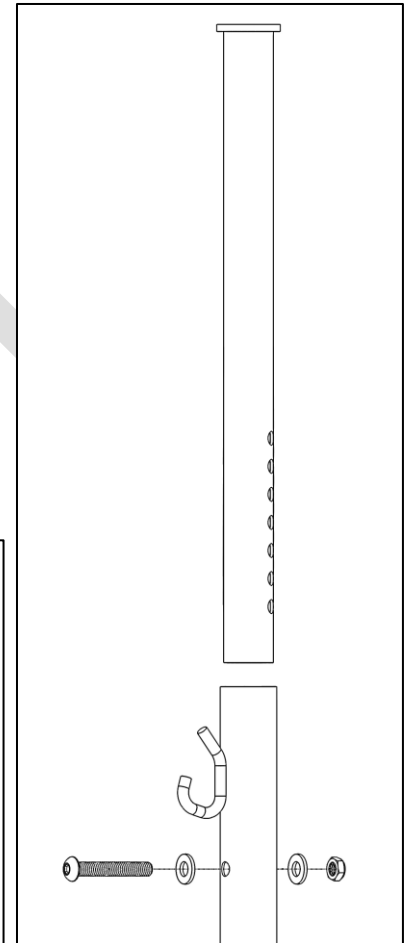

### **Step 4 – Install Support Arm to Front Leg**

- Place support arm in desired location between front leg and inside of service body bed side.
  - As close to 45 degrees as possible is best.
  - The bends in the support arm should be as flat as possible with the inside of service body.
  - **Ensure clearance inside the service body, at opposite side of support arm, to drill and install nut and washer inside service body.**
- Mark location of support arm hole on front leg.
- Using a 17/32" drill bit, drill through leg.

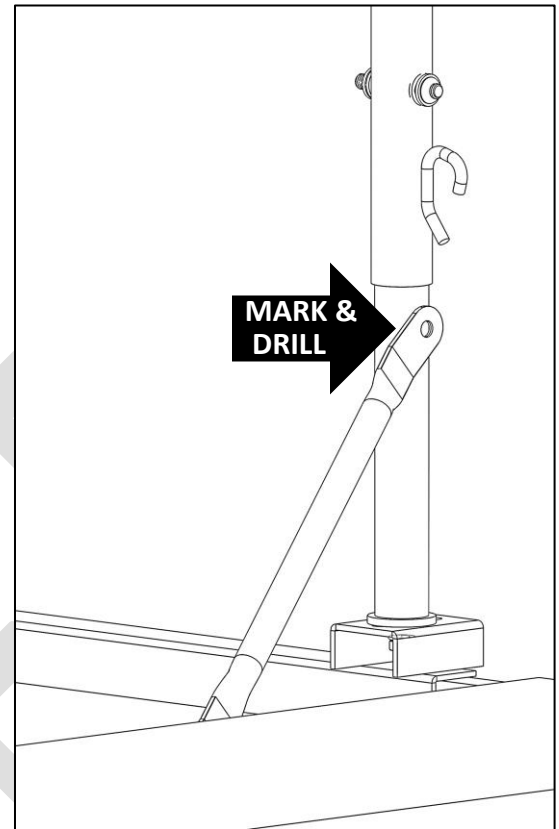

- Using a 1/2" x 3" button head screw, two 1/2" washers, and 1/2" lock nut, bolt support arm to leg.
- Snug tighten but allow for movement.
- Repeat for opposite side.

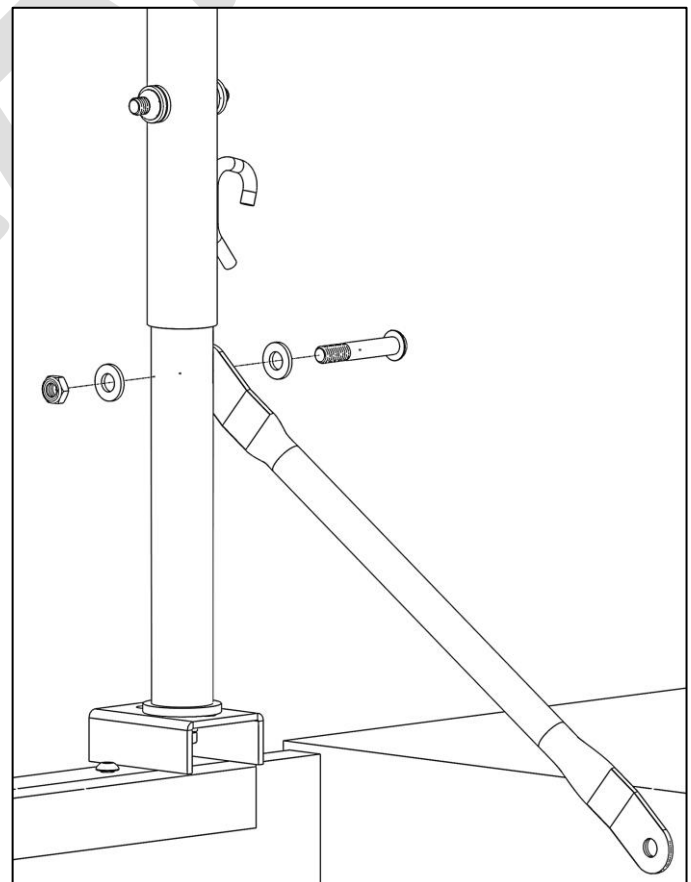

## **Step 5 – Install Support Arm to Service Body**

Follow the following instructions in place of Step 11 of *Pro II Service Body Rack Instructions*.

- Hold support arm in desired installation position.
  - As close to 45 degrees as possible is best.
  - **Ensure clearance inside the service body, at opposite side of support arm, to drill and install nut and washer inside service body.**
- Mark location of support arm hole on inside of service body bed side.



**Be sure drilling location is clear of wires, fuel tanks and lines, brake lines and other important vehicle functionality items.**

- Using 13/32" drill bit, drill holes through side panel of service body where marked.
- Using one 3/8" button head screw, two 3/8" washers, and one 3/8" lock nut, loosely attach support arm to service body side panel.
- Snug tighten but allow for movement.
- Repeat for opposite side.

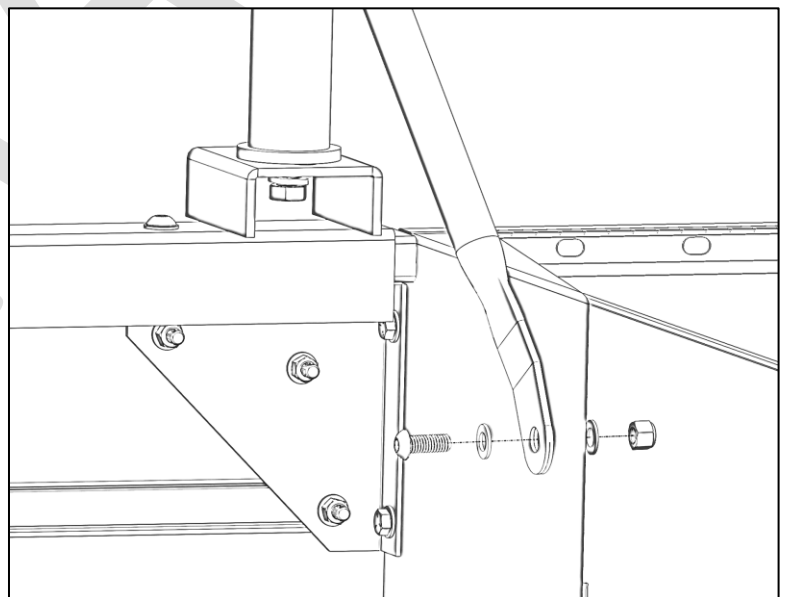
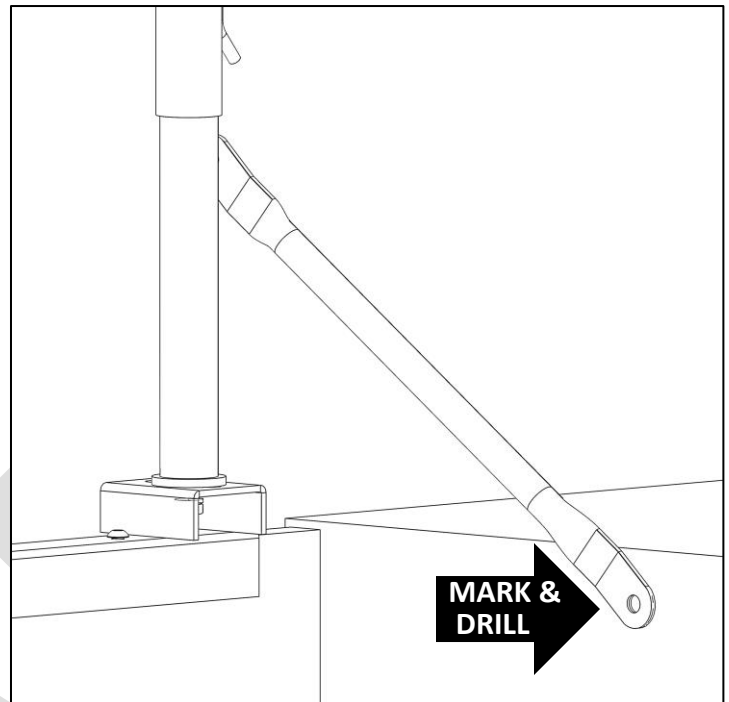

**GO BACK AND ENSURE ALL HARDWARE IS TIGHTENED.**

**ASSEMBLY IS COMPLETE**