

KARGO MASTER®

WE PUT EVERYTHING WITHIN REACH.

Installation Instructions

Pro II Truck Rack

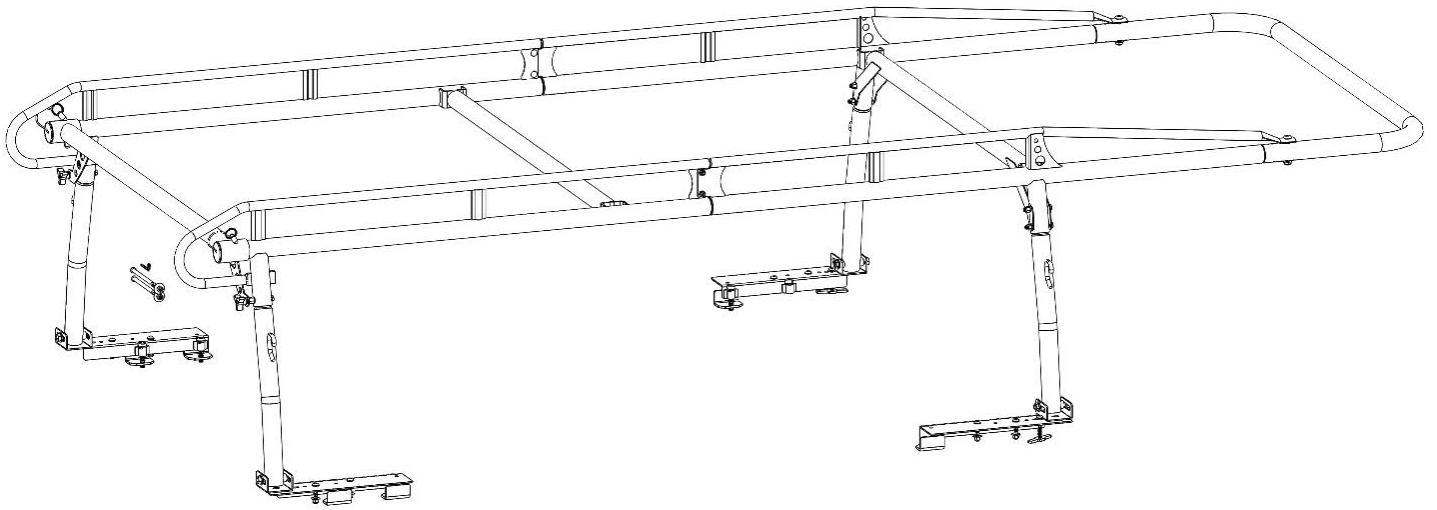

* PLEASE READ ALL INSTRUCTIONS AND WARNINGS PRIOR TO ASSEMBLING, INSTALLING, AND USING THIS PRODUCT. *

Warning



Always check for wires, fuel tanks and lines, brake lines and other important vehicle functionality items prior to drilling and installing all products.



Too much weight will greatly reduce the stability of your vehicle. Kargo Master makes no representation or warranty as to the amount of weight your vehicle can safely carry. For guidance, we recommend that you consult the vehicle manufacturer. At no time should the weight of the vehicle, rack, driver, passengers and cargo loaded on a Kargo Master rack exceed either the Gross Vehicle Weight Ratio (GVWR) or the Gross Axle Weight Ratio (GAWR) as specified by the vehicle manufacturer.



Do not use your rack with the rear cross bar removed. Removal of rear crossbar will affect structural integrity of the rack.



Secure all payloads properly for safe transportation.

* A large area is required to assemble rack. Be sure to keep area clear of trip and fall hazards. *

Before You Begin

- Read all instructions carefully, and follow each step in proper sequence, for ease and speed in assembling your Kargo Master rack.

Table of Contents







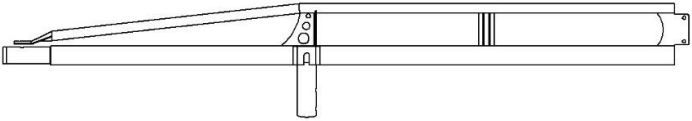
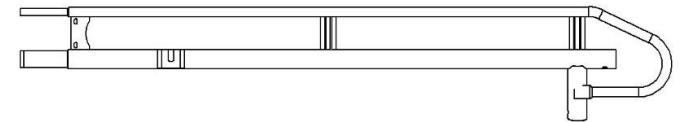
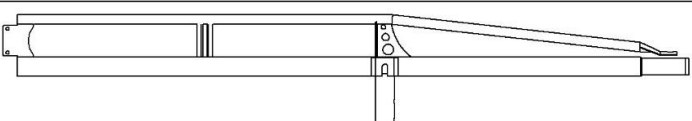
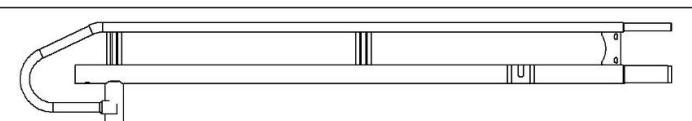

| | |
|--|----|
| Tools Needed..... | 2 |
| Parts List..... | 3 |
| Assembly Hardware | 4 |
| Sealant Application..... | 9 |
| Step 1 – Join Side Channels..... | 9 |
| Step 2 – Attach Front Tube | 10 |
| Step 3 – Attach Center Crossbar | 10 |
| Step 4 – Attach Front Legs and Front Crossbar | 10 |
| Step 5 – Attach Rear Legs | 11 |
| Step 6 – Attach Rear Crossbar | 12 |
| Step 7 – Foot Installation | 12 |
| Step 7A – Foot Installation Using Stake Pockets..... | 12 |
| Step 7B – Foot Installation Using Rail Clamps..... | 14 |
| Step 7C – Foot Installation Using Permanent Mounting Locations | 15 |
| Step 8 – Rack Installation | 16 |

Tools Needed

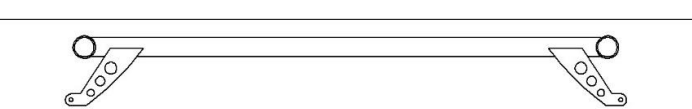
| | |
|------------------------------|---------------------------------|
| 9/16", 3/4" Box Wrenches | 9/16", 1/2", 3/4" Socket Wrench |
| 7/32", 5/16" Allen Wrenches* | Deep Socket Wrench |
| 3/8" Drill Bit | Drill |
| Center Punch | Hammer |
| Locking C-clamp | Torque Wrench |

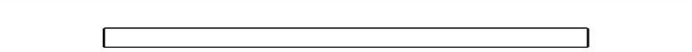
* Included.

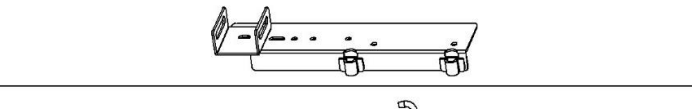

Parts List

| ITEM NO. | | MODEL / PART NUMBER | DESCRIPTION | QTY. |
|----------|---|--|--------------------------------------|------|
| 1 |  | 04000 / 100616 06000 / 100626 06010 / 100624 | SIDE CHANNEL, FRONT PS RH | 1 |
| 2 |  | 04000 / 100620 06000 / 100630 06010 / 100620 | SIDE CHANNEL, REAR PS RH | 1 |
| 3 |  | 04000 / 100617 06000 / 100627 06010 / 100625 | SIDE CHANNEL, FRONT DS LH | 1 |
| 4 |  | 04000 / 100621 06000 / 100631 06010 / 100621 | SIDE CHANNEL, REAR DS LH | 1 |
| 5 |  | 11-00000 | FRONT TUBE | 1 |
| 6 |  | 100642 | REAR CROSS BAR | 1 |
| 7 |  | 13-00020 | FRONT CROSS BAR | 1 |
| 8 |  | 13-00031 | CENTER CROSS BAR | 1 |
| 9 |  | 13-00996 | FOOT PLATE, DS | 2 |
| 10 |  | 13-00997 | FOOT PLATE, PS | 2 |
| 11 |  | 01000 / 13-00087 01040 / 13-00084 | LEG ASSEMBLY | 4 |
| 12 | | 18-00001A | ASSEMBLY HARDWARE | 1 |
| 13 | | 18-00001M | MOUNTING HARDWARE | 1 |
| 14 | | 18-00001GM | REAR STAKE POCKET MOUNTING KIT | 1 |

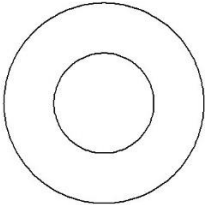
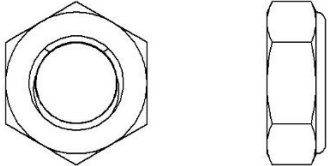
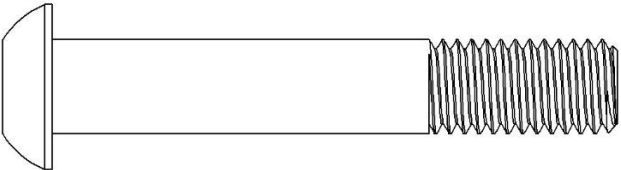
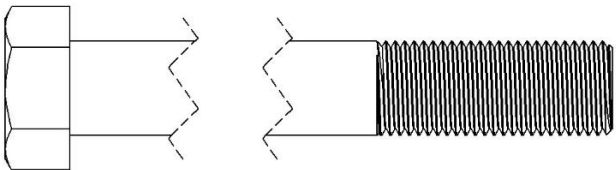
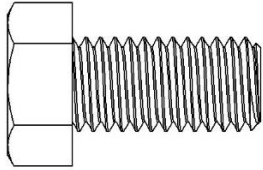
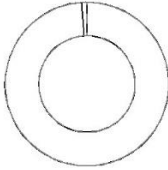
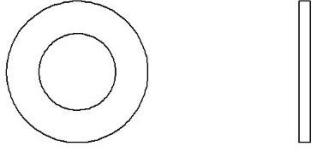
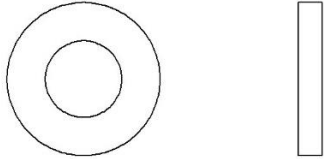
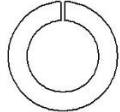

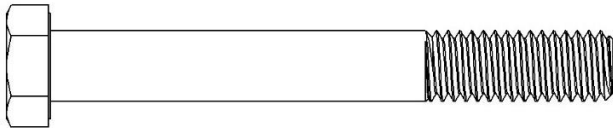
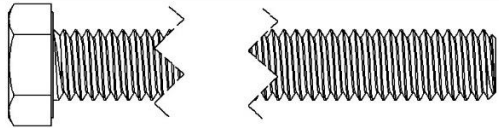
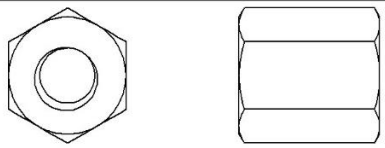
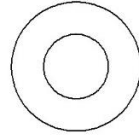
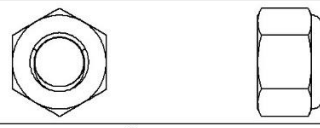
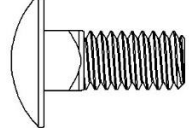
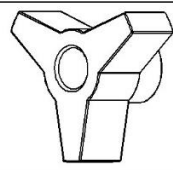

Assembly Hardware Kit

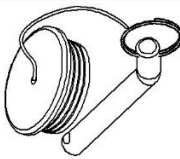
| ITEM | HARDWARE TO SCALE | PART NO. | DESCRIPTION | QTY. |
|------|---|----------|------------------------------------|------|
| 1 |  | 11541086 | 1/2" WASHER | 16 |
| 2 |  | 37695 | 1/2"-13 THIN LOCKING JAM NUT | 7 |
| 3 |  | 42KD91 | 1/2"-13 X 3" BUTTON HEAD CAP SCREW | 2 |
| 4 |  | 11105810 | 1/2"-13 X 3-3/4" HEX HEAD BOLT | 4 |
| 5 |  | 11241227 | 1/2"-13 x 1" HEX HEAD BOLT | 4 |
| 6 |  | 1133626 | 1/2" SPLIT LOCK WASHER | 6 |
| 7 |  | 11541089 | 3/8" WASHER | 15 |
| 8 |  | 11101304 | 3/8" OVERSIZED FLAT WASHER | 2 |
| 9 |  | 0123496 | 3/8" SPLIT LOCK WASHER | 3 |

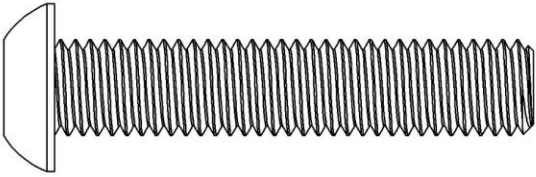
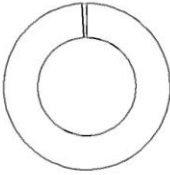
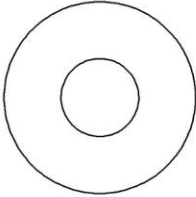
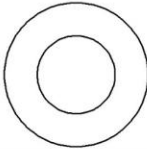
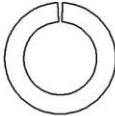
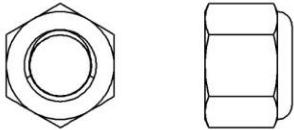
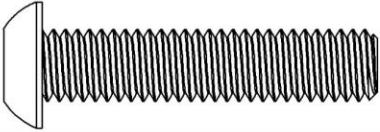
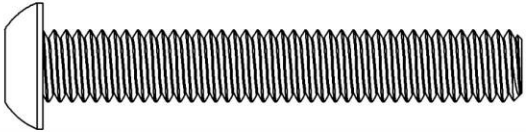

Assembly Hardware Kit (Cont.)

| ITEM | HARDWARE TO SCALE | PART NO. | DESCRIPTION | QTY. |
|------|---|----------|---|------|
| 10 |  | 0169791 | 3/8"-16 LOCK NUT | 5 |
| 11 |  | 70115 | 3/8"-16 X 3" HEX HEAD BOLT | 4 |
| 12 |  | 13819 | 3/8"-16 X 3-1/2" HEX HEAD BOLT, FULL THREAD | 2 |
| 13 |  | 37820 | 3/8"-16 X 3/4" COUPLING NUT | 2 |
| 14 |  | 11541083 | 5/16" WASHER | 7 |
| 15 |  | 0169777 | 5/16"-18 NYLOC | 5 |
| 16 |  | 21810 | 5/16"-18 X 3/4" CARRIAGE BOLT | 4 |
| 17 |  | 11101570 | 3/8"-16 3-ARM KNOB (1:2 SCALE) | 2 |
| 18 |  | 26524 | 7/32" HEX WRENCH (2:3 SCALE) | 1 |
| 19 |  | 26528 | 5/16" HEX WRENCH (2:3 SCALE) | 1 |
| 20 |  | 13-00003 | REAR PIN & CAP ASSY (2:3 SCALE) | 2 |
| 21 | | | SEALANT | 2 |

Mounting Hardware Kit

| ITEM | HARDWARE TO SCALE | PART NO. | DESCRIPTION | QTY. |
|------|---|----------|--|------|
| 1 |  | 0185355 | 1/2"-13 X 2-1/2" BUTTON HEAD BOLT | 6 |
| 2 |  | 1133626 | 1/2" SPLIT LOCK WASHER | 8 |
| 3 |  | 78018 | 3/8" X 1" OD OVERSIZE WASHER | 10 |
| 4 |  | 11541089 | 3/8" FLAT WASHER | 12 |
| 5 |  | 0123496 | 3/8" STEEL LOCK WASHER | 4 |
| 6 |  | 0169791 | 3/8"-16 LOCK NUT | 11 |
| 7 |  | 94095 | 3/8"-16 X 1-3/4" BUTTON HEAD CAP SCREW | 10 |
| 8 |  | 94718 | 3/8"-16 X 2-1/2" BUTTON HEAD CAP SCREW | 2 |
| 9 |  | 11-00700 | RAIL CLAMP (1:4 SCALE) | 6 |
| 10 |  | 100578 | RAIL CLAMP, FULL SIZE (1:4 SCALE) | 6 |
| 11 |  | 11-00112 | 3/8"-16 T-NUT | 2 |

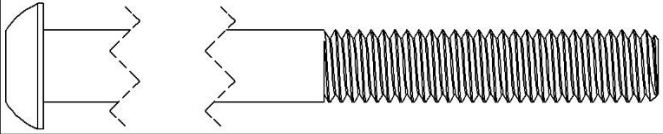
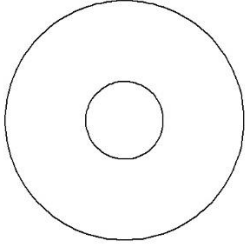
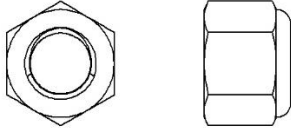
Rear Stake Pocket Mounting Kit

| ITEM | HARDWARE TO SCALE | PART NUMBER | DESCRIPTION | QTY. |
|------|--|-------------|--------------------|------|
| 1 |  | - | 3/8"-16 X 8" BH | 2 |
| 2 |  | 33220 | 3/8" FENDER WASHER | 2 |
| 3 |  | 0169791 | 3/8"-16 LOCK NUT | 2 |
| 4 |  | 36315 | T15 TORX WRENCH | 1 |

CENTER CROSSBAR SHIM

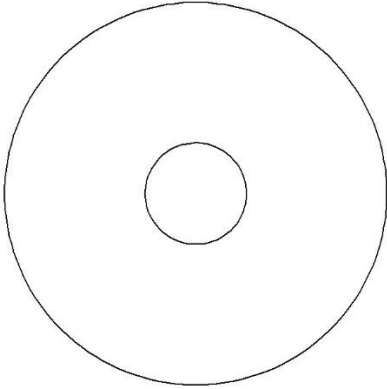
| ITEM | HARDWARE TO SCALE | PART NO. | DESCRIPTION | QTY. |
|------|---|----------|---------------------|------|
| 1 |  | 100714 | 1/2" X 2" OD SPACER | 2 |

PRO II TRUCK RACK EXPLODED VIEW

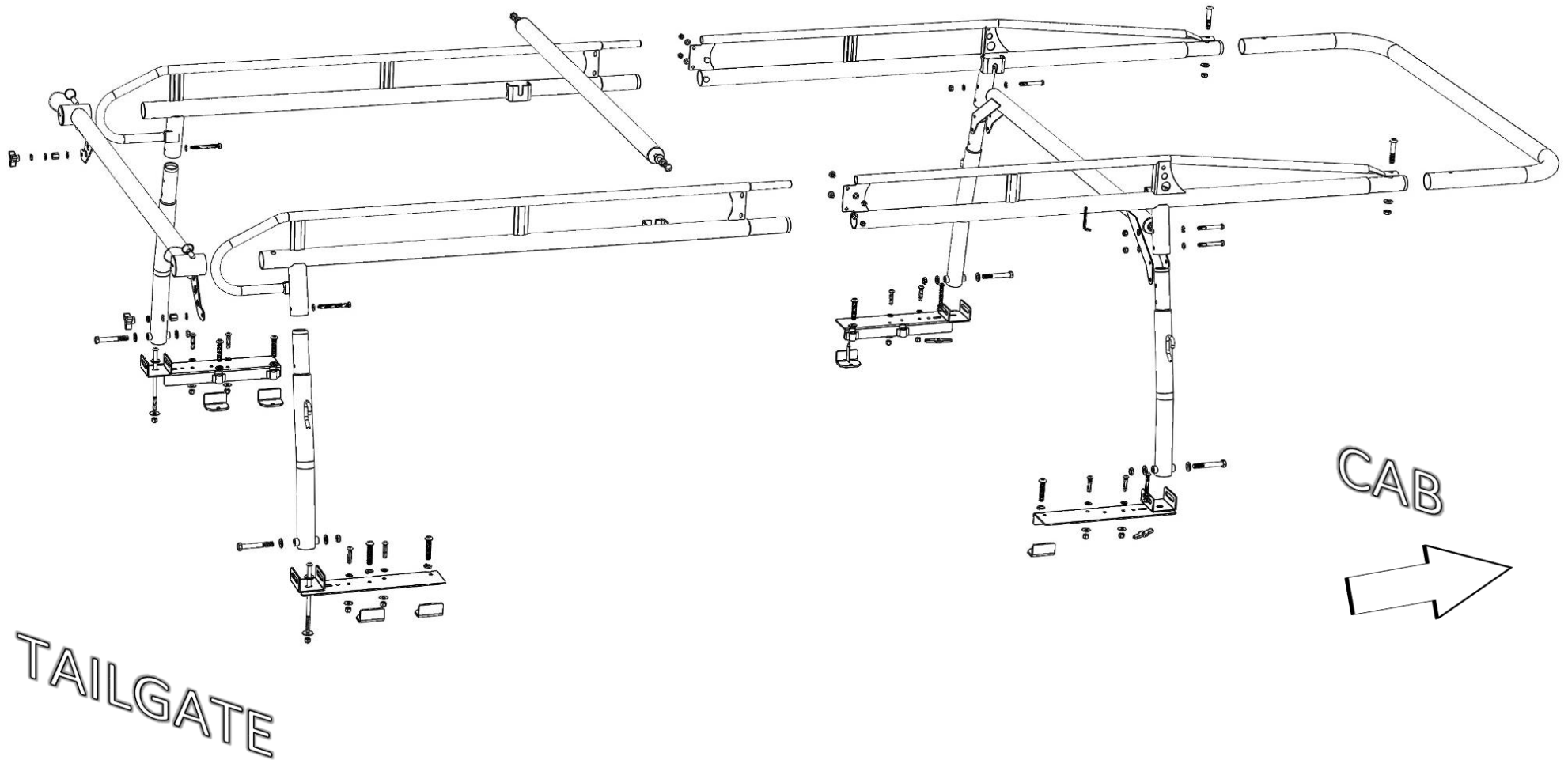

Sealant Application

- Proper sealant application is critical to preventing water penetration inside the rack.
- Apply a healthy bead of sealant around every swaged joint as shown. Improper sealing can lead to water penetration and rust on inside surfaces.

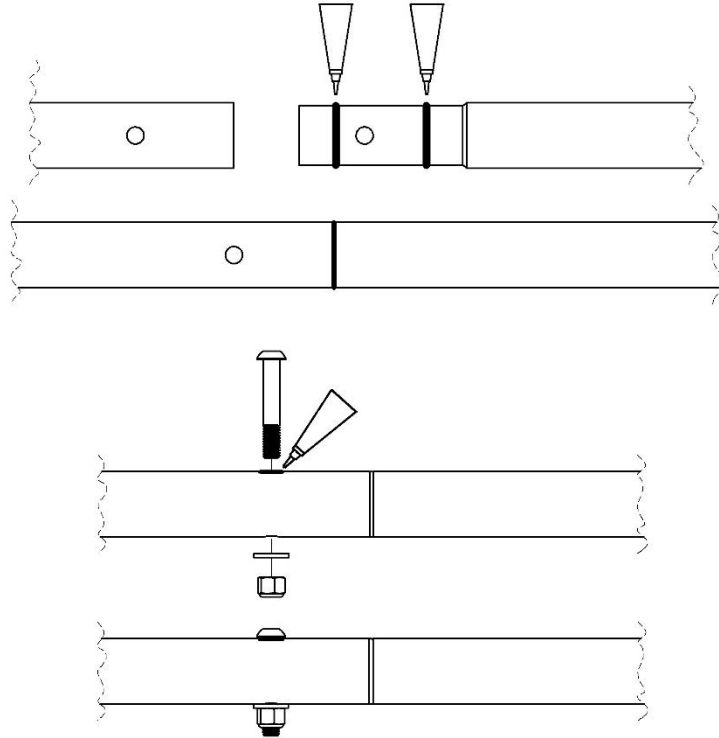

- Wipe any excess sealant off immediately with a plastic scraper or paper towel. Any smeared sealant can be rubbed off as soon as sealant dries.
- Maintain this seal throughout the life of your rack.

Step 1 – Join Side Channels

- Unpack side channels from box. Lay flattened box on ground and use for scratch protection while building rack.
- Open Assembly Hardware Kit.
- Be sure you have correct front and rear side channels paired.
- Apply sealant to both top and bottom swage joints.
- Insert rear side-channel swaged joints into front side-channel tubes until bolt holes in splice plates align.
- Using 5/16" x 3/4" carriage bolts, 5/16" washers, and 5/16" lock nuts, securely fasten channels together.
- Remove excess sealant.
- Repeat process for opposite side.

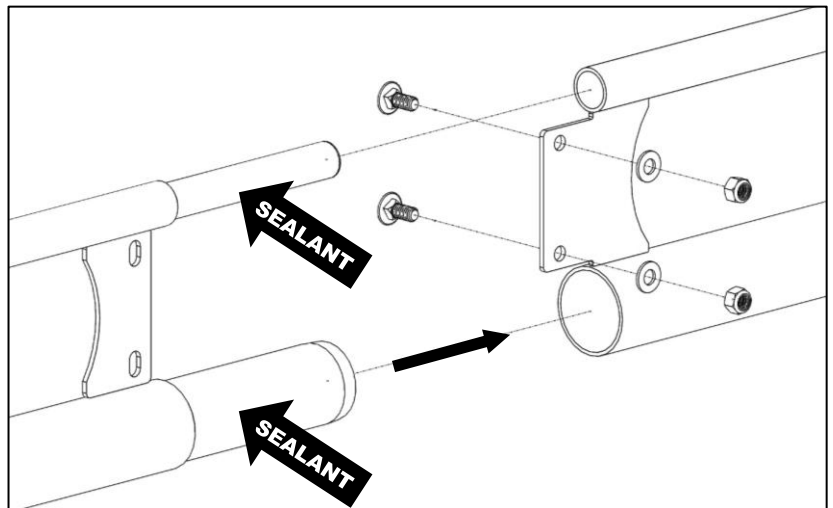

Step 2 – Attach Front Tube

- Apply sealant to front side-channel swaged joint.
- Insert front side-channel swaged joint into front tube until bolt holes in tube and side-channel align.
- Loosely fasten front tube to side channel using 1/2" x 3" partially threaded button head screw, 1/2" washer, and 1/2" lock nut.
- Remove excess sealant.
- Repeat process on opposite side.

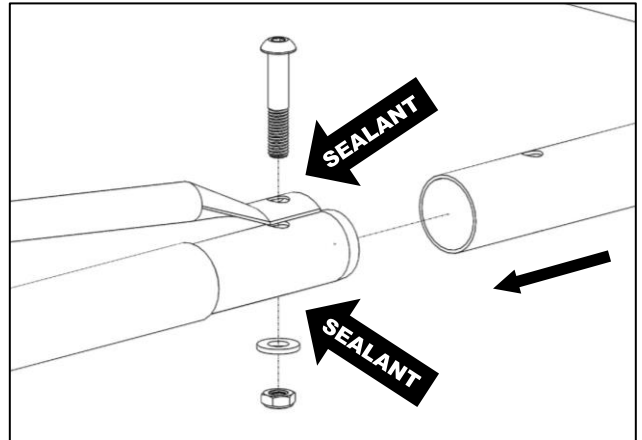

Step 3 – Attach Center Crossbar

- Thread one 1/2" x 1" hex bolt, one 1/2" lock washer, and one 1/2" washer about 1/4" deep into each end of front crossbar.
- Insert center crossbar into center crossbar bracket. Be sure 1/2" washers are NOT between crossbar and crossbar bracket.
- Lightly tighten 1/2" bolts on both sides.

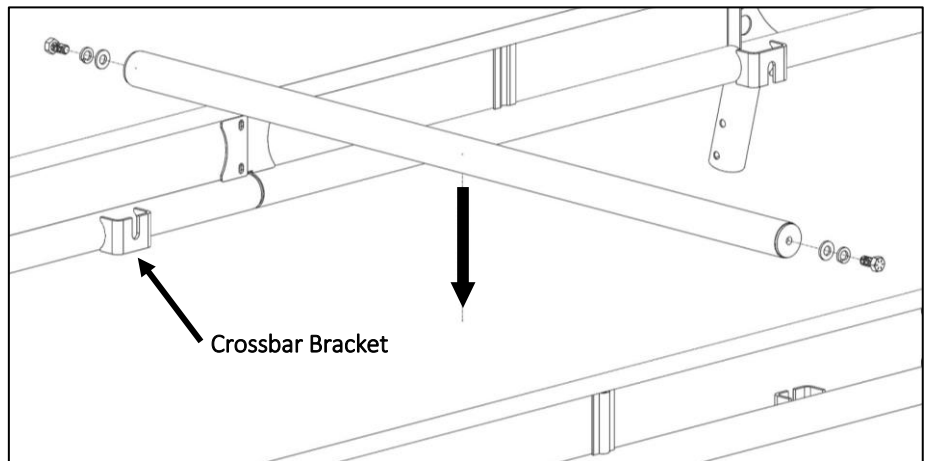

Step 4 – Attach Front Legs and Front Crossbar

- Flip rack upside down.
- Thread one 1/2" x 1" hex bolt, with one 1/2" lock washer and one 1/2" flat washer, about 1/4" deep into each end of front crossbar.
- Slide front crossbar over leg cup into crossbar bracket. Be sure 1/2" washers are NOT between crossbar and bracket.
- Apply sealant to swaged joint on one leg.
- Orient leg correctly with side channel, with rope hook away from center of rack, and then insert leg into leg cup until bolt holes through leg, front crossbar flange, and leg cup align.
- Remove excess sealant.

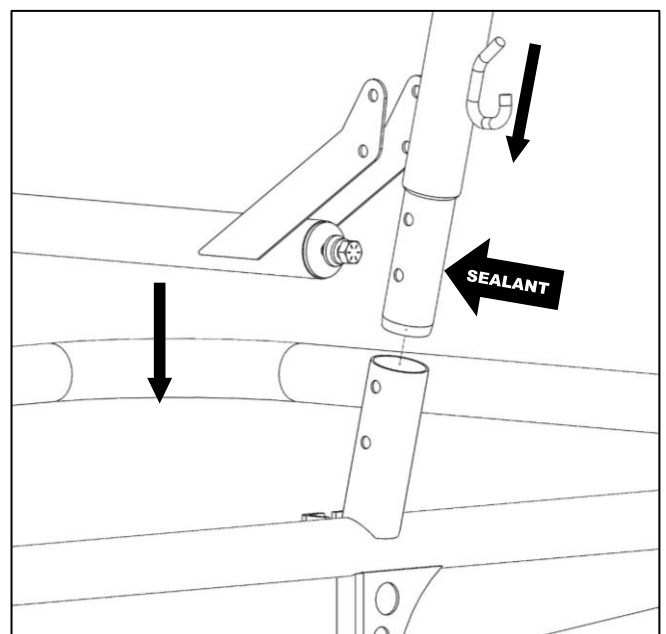

- Be sure to apply sealant between each washer and leg cup as you assemble.
- Fasten and seal leg to leg cup using two 3/8" x 3" hex head bolts, four 3/8" washers and two 3/8" lock nuts. Tighten nut to bolt to 35 ft-lb.
- Remove excess sealant.
- Repeat process on opposite side.

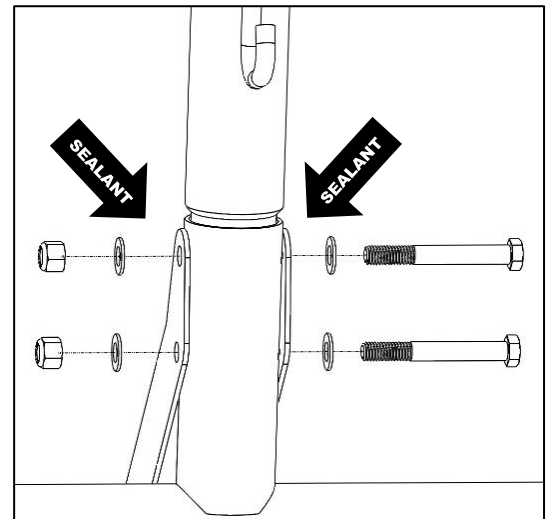

Step 5 – Attach Rear Legs

- Apply sealant to swaged joint on one leg and around holes in leg cup.
- Orient leg correctly with side channel, with rope hook away from center of rack, and then insert leg into leg cup until holes through leg and leg cup align.
- Be sure to apply sealant around bolt between each washer and leg cup as you assemble.
- Lightly fasten leg to leg cup using , one 3/8" x 3-1/2" fully-threaded hex head bolt, one 3/8" washers, one 3/8" oversize washer, and one 3/8" coupling nut. Make sure oversize washer and coupling nut are towards rear end of rack.
- Remove excess sealant.
- Repeat process on opposite side.

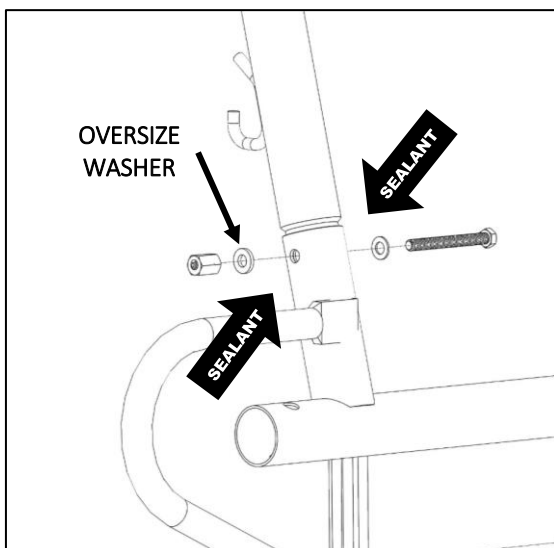
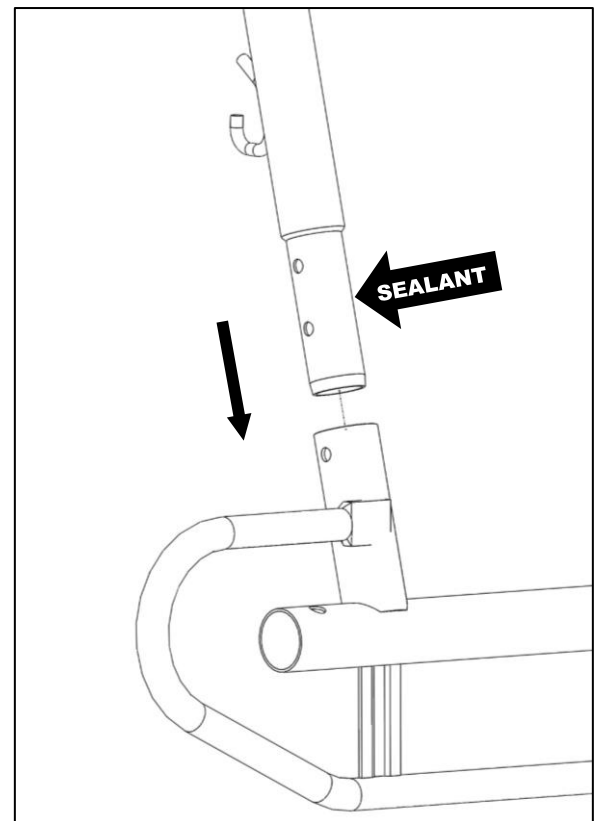

Step 6 – Attach Rear Crossbar

- Apply sealant to around black cap fastening flanges.
- Using a mallet or dead blow hammer, tap black cap into rear crossbar tubing on the side opposite the gusset welded to the rear crossbar.
- Remove excess sealant.
- Flip rack right side up.
- Slide rear crossbar ends onto rear side-channel tubes.
- Insert lock pin through holes in rear crossbar end and rear side-channel tube.
- Lightly fasten rear crossbar using one 3/8" washer, 3/8" lock washer, and 3/8" knob.
- Repeat on opposite side.

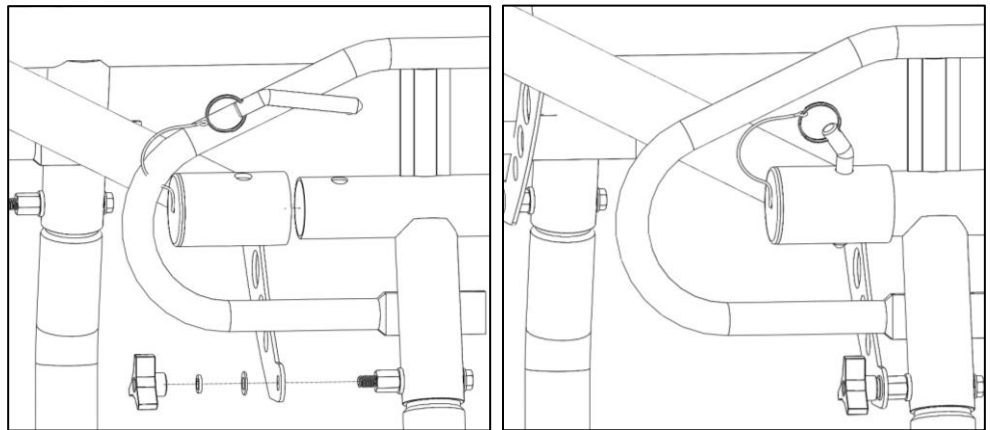
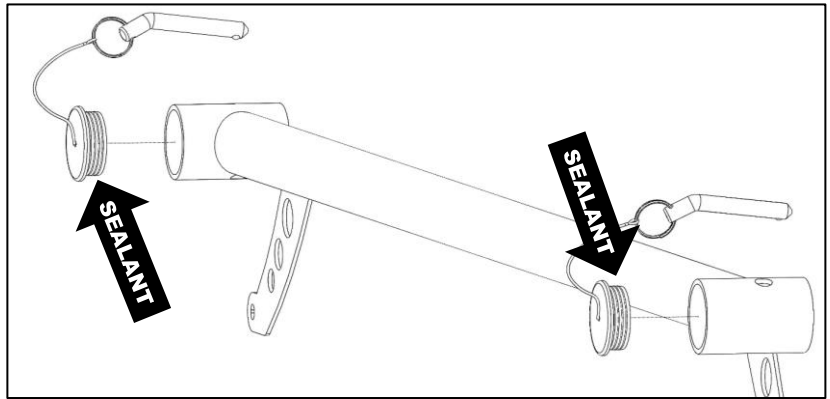

Step 7 – Foot Installation



It is recommended the feet are secured to the truck bed using the structural stake pockets incorporated into the bed. It is also recommended that more than one type of method of attachment is used for mounting each foot.

Recommended foot installation combinations are as follows:

- Stake pocket installation and rail clamp installation
- Stake pocket installation and permanent mounting option

Step 7A – Foot Installation Using Stake Pockets

- Open Rear Stake Pocket Mounting Kit and Mounting Hardware Kit.
- Remove rear bed-rail stake pocket cover.
- Position the rear foot on the truck bed rail with the hole in the rear slotted channel aligned over the stake pocket.
- Remove or cut out the front bed-rail stake pocket cover.

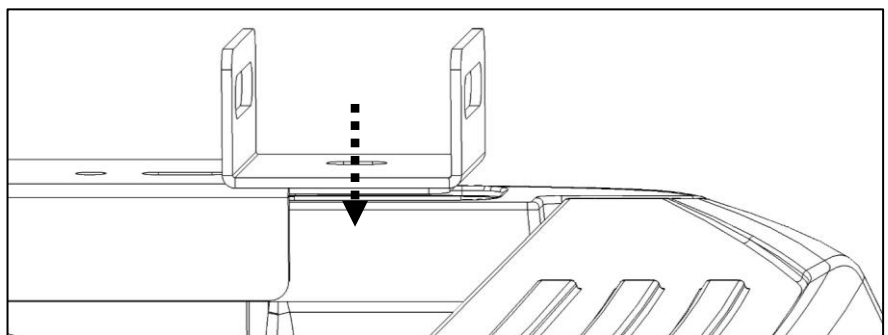

- Set the corresponding front foot, on the bed rail, near the front of the bed, so that the distance between the slotted channels corresponds with the length for the model number being assembled. The table below lists the lengths for all model numbers.

| Truck Rack Side Channel Model Number | Distance between slotted channels |
|--------------------------------------|-----------------------------------|
| 04000 | 93-1/4" |
| 06000 | 93-1/4" |
| 06010 | 76" |

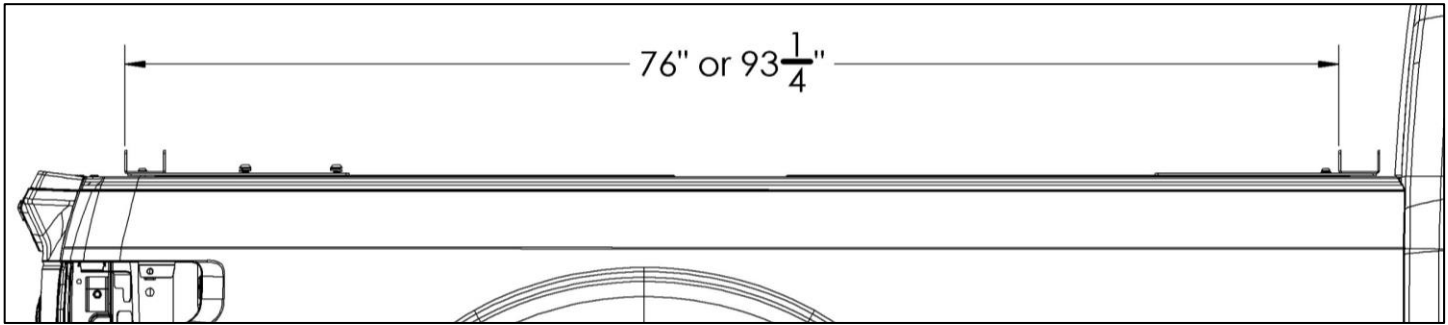

- For Ford and Chevy trucks, remove the rear taillight. A T15 Torx wrench is supplied to remove Chevy taillights.
- On the rear foot, insert the 3/8" x 8" button head screw through the hole in the rear slotted channel and the hole in the bottom of the rear stake pocket.
- Install the 3/8" fender washer and 3/8" lock nut onto the 3/8" x 8" button head screw.
- Determine the slot in the front foot that best aligns with the front stake pocket. Be sure to keep the front and rear feet at the correct distance.

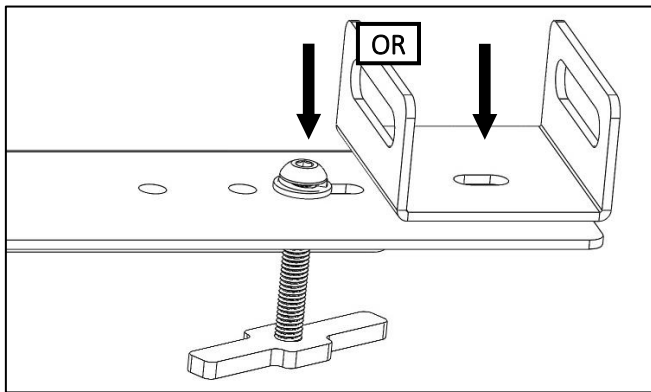
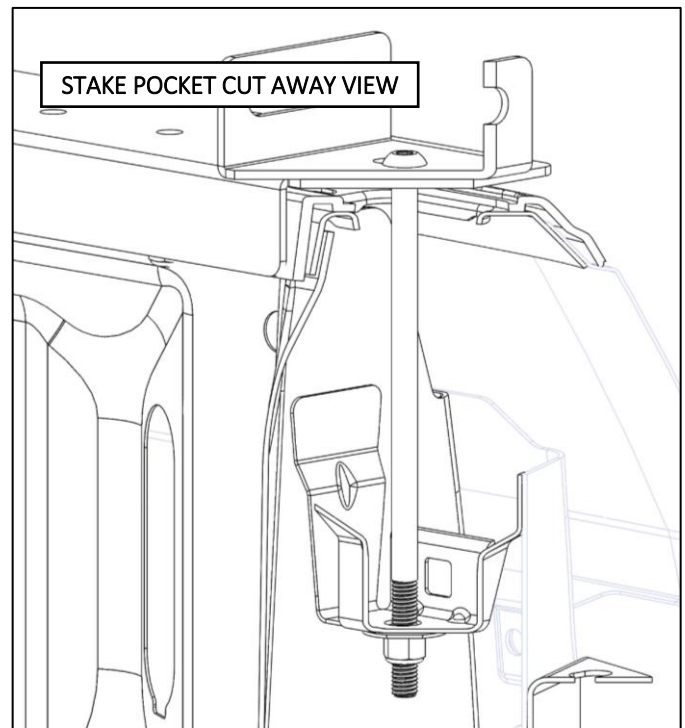

- Remove front foot and insert a 3/8" x 2-1/2" button head screw, a 3/8" lock nut, and 3/8" flat washer through the chosen slot into a 3/8" t-nut.
- Install the front foot back onto the bed rail, inserting the 3/8" t-nut into the stake pocket hole. Be sure to maintain the distance between the front foot and rear foot.
- With the front foot at the correct distance, snugly tighten the 3/8" x 2-1/2" button head screw until the t-nut is bound beneath the metal stake pocket hole.

Step 7B – Foot Installation Using Rail Clamps

- There are two types of rail clamp included in the mounting hardware. For newer Ford, Chevy, and GMC models, the full-size rail clamp should provide a best fit. When installing the feet, it is best to verify the clamp that best fits at each location chosen for installation.
- Verify that the distance between front foot and rear foot is correct.
- Insert a 1/2" x 2-1/2" button head screw and 1/2" lock washer through the rear saddle on the front foot into a rail clamp.
- With the front foot tightly against the inside of the bed rail, using your hand, pull the rail clamp upward until clamp is contacting the underside of the bed rail, free of obstacles, and then tighten the 1/2" x 2-1/2" button head screw.
- On the rear foot, install a 1/2" x 2-1/2" button head screw and 1/2" lock washer through each of the saddles and into a rail clamp.
- With the rear foot tightly against the inside of the bed rail, pull the rail clamp upward until clamp is contacting the underside of the bed rail and free of obstacles. Tighten the 1/2" x 2-1/2" button head screw.
- Install second rear rail clamp same as previous.
- Repeat foot installation steps on opposite side of bed. Be sure to keep feet on opposing sides of the vehicle aligned front-to-back. The distance between the tailgate and end of foot should be the same on both sides of the vehicle.

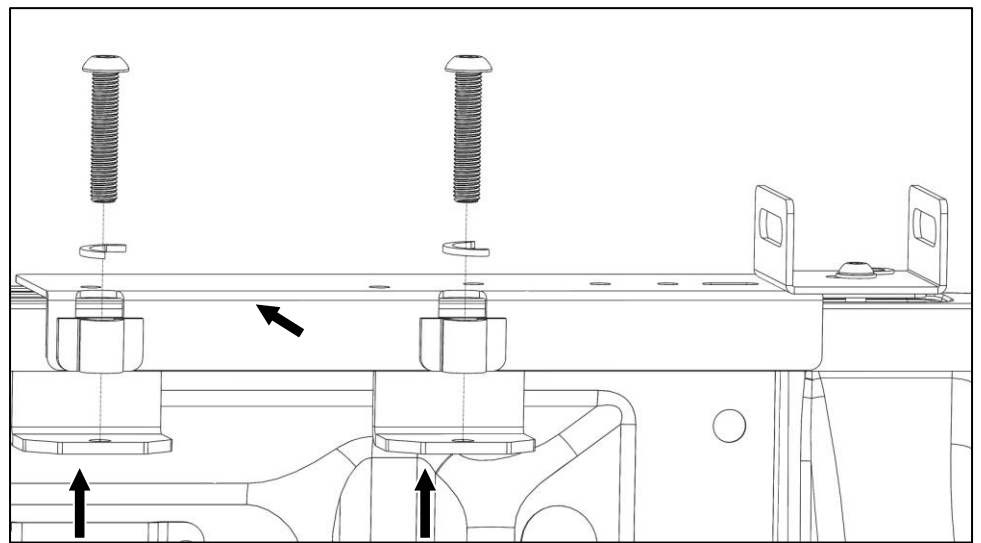
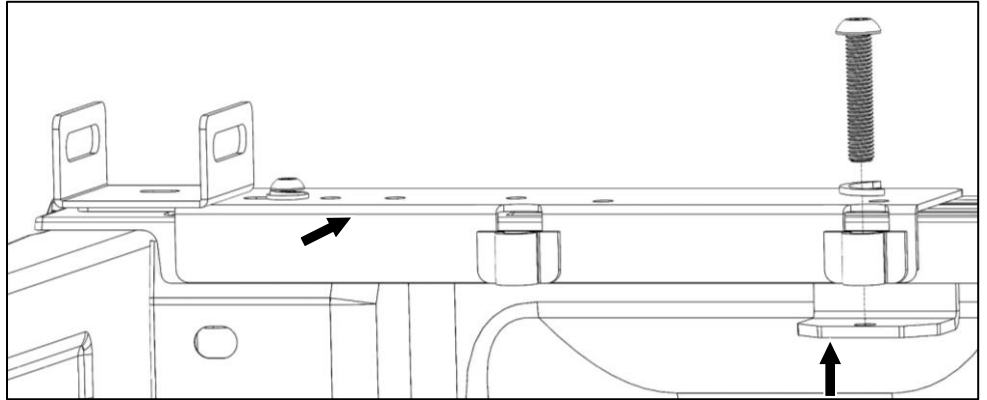

Step 7C – Foot Installation Using Permanent Mounting Locations

- The following table describes the recommended permanent foot mounting locations.

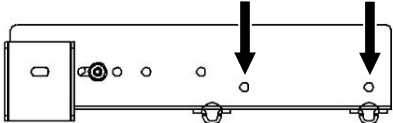
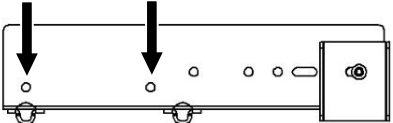
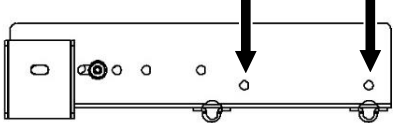
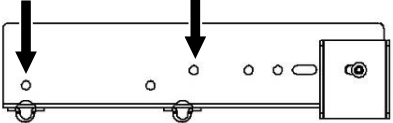
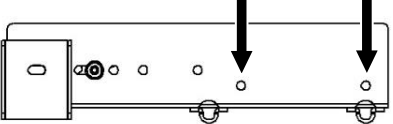
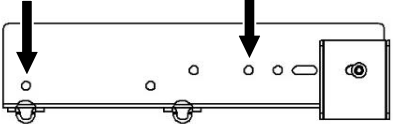
| VEHICLE | FRONT FOOT | REAR FOOT |
|---------------------------------|---|---|
| FORD F-150, SUPERDUTY |  |  |
| GMC / CHEVROLET FULL-SIZE |  |  |
| DODGE RAM |  |  |

- Verify the permanent mount location is accessible from inside the bed, below the bed rail. Different vehicles have different possible mounting locations.
- With foot in place and at the correct distance between front and rear feet, mark on the bed rail location of permanent mounting holes.
- Remove foot.
- Using a 13/32" drill bit, drill through the bed rail at the marked locations
- Reinstall foot into prior position.
- Install a 3/8" x 1-3/4" button head screw and 3/8" flat washer through each hole into a 3/8" oversize washer and 3/8" lock nut.

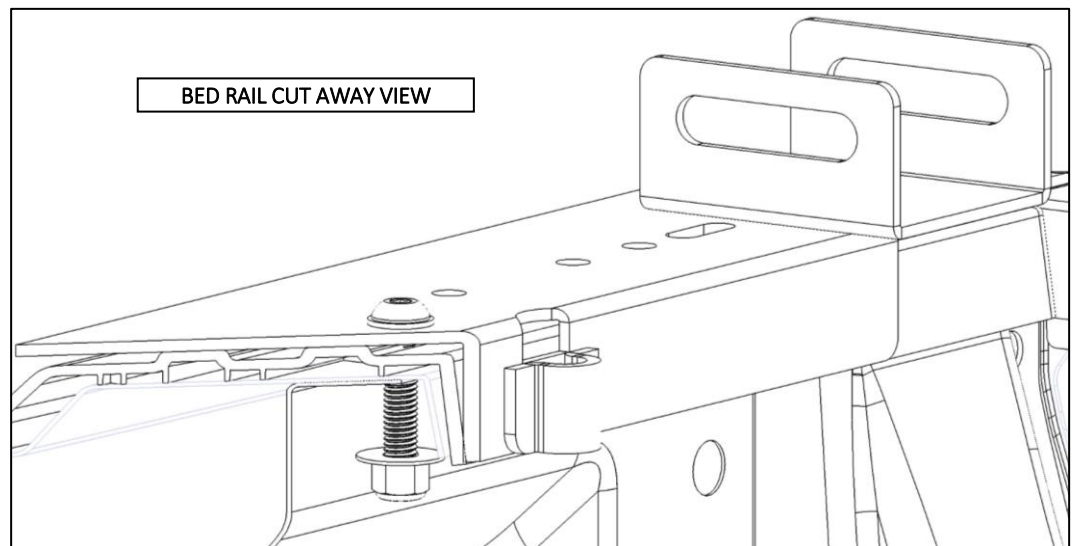

Step 8 – Rack Installation

- Lift rack and set legs into slotted channel.

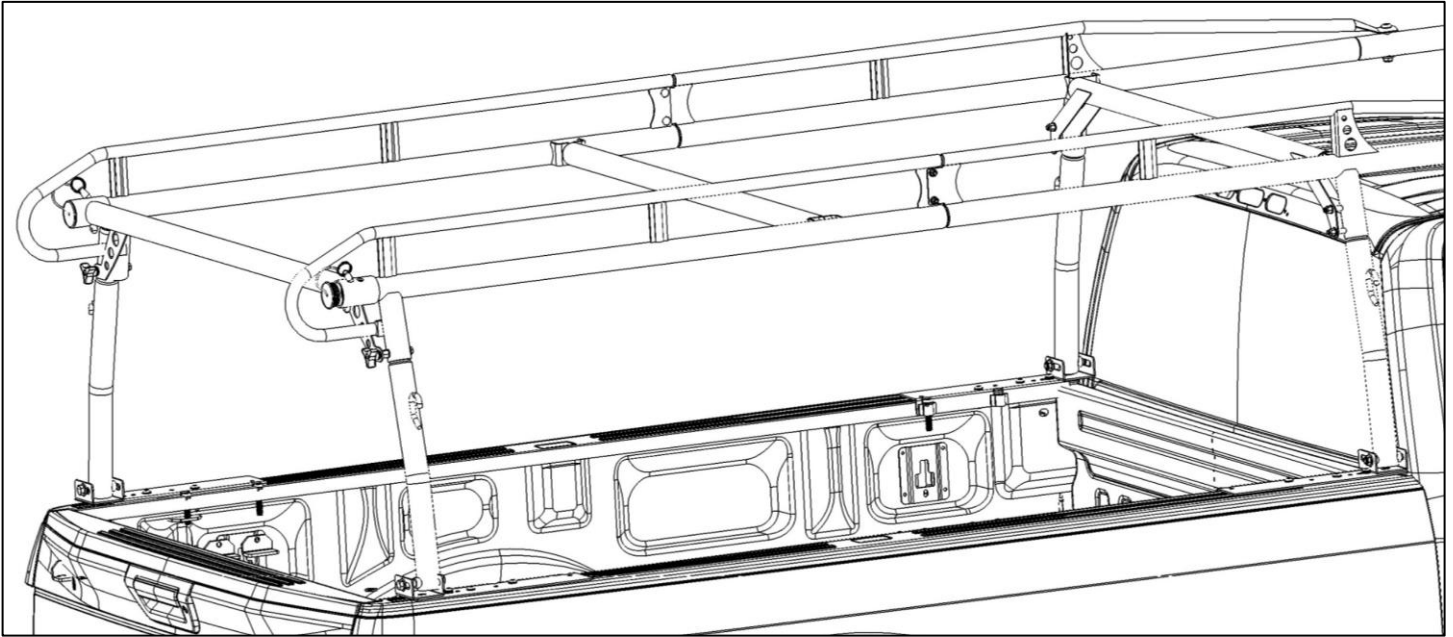

- Insert 1/2" x 3-3/4" hex head bolt and 1/2" flat washer through slotted channel and leg.
- Loosely install 1/2" washer and 1/2" jam nut onto opposite end of 1/2" x 3-3/4" hex head bolt.
- Repeat for each leg.
- With lock pins installed, tighten all side channel and upper front leg screws and bolts.
- Center the rack side-to-side over the bed.
- Tighten 1/2" jam nuts onto 1/2" x 3-3/4" hex head bolts to 38 ft-lb.
- Tighten center crossbar bolts.
- Tighten 3/8" coupling nut to 3/8" x 3-1/2" fully threaded hex head bolt from Step 5 to 35 ft-lb.
- Ensure all hardware is tightened.

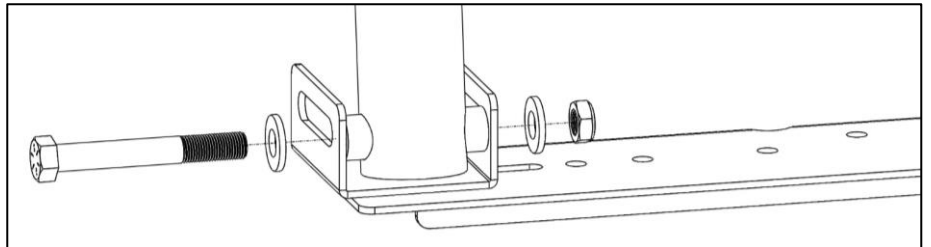

- Reinstall taillights.
- Verify rear crossbar lock-pin pulls in and out easily. If necessary, loosen rear crossbar knobs and center crossbar, and then slide rear crossbar hard left then right about 10 times to get lock-pins to seat properly.
- If lock-pin still binds, remove center crossbar, insert 1/2" x 2" OD spacer between one side of center crossbar and side channel saddle bracket. A second spacer is provided in case lock pin still binds after addition of first spacer.

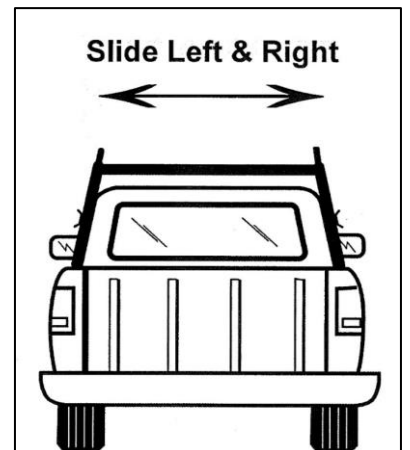
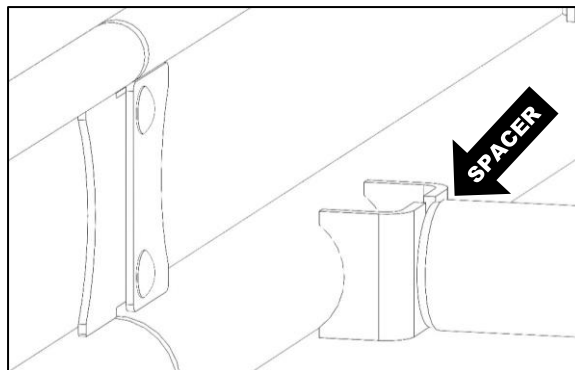

DON'T OVERLOAD YOUR VEHICLE!

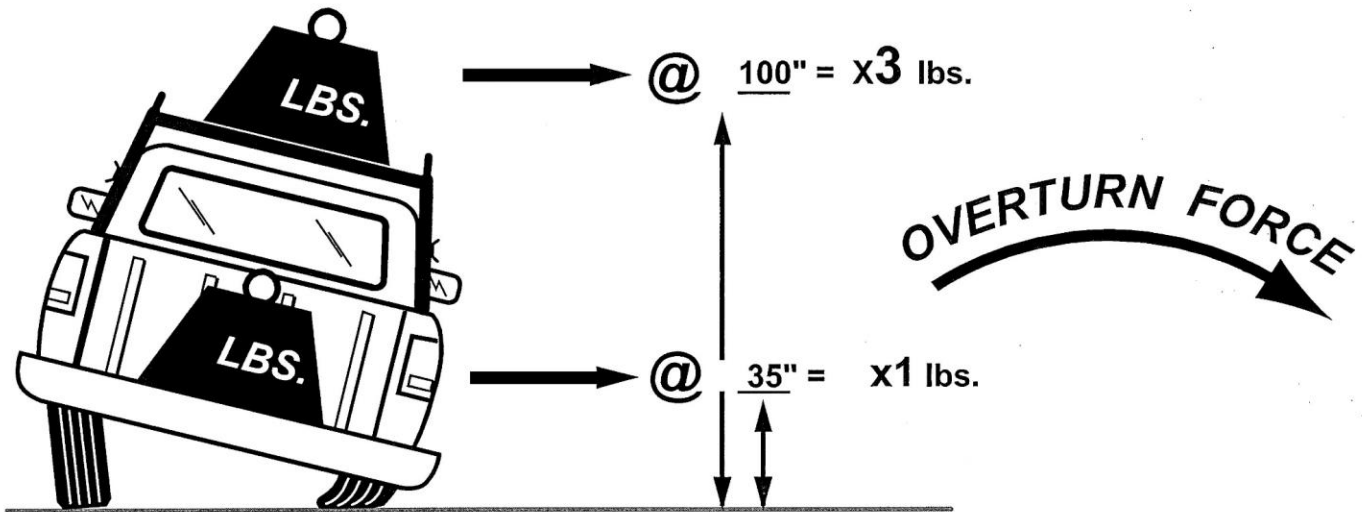

WEIGHT CARRIED ABOVE THE FLOOR OF THE TRUCK BED (E.G. ON AN OVERHEAD TRUCK RACK) WILL SIGNIFICANTLY INCREASE THE VEHICLE'S TENDENCY TO OVERTURN. ALWAYS KEEP HEAVY LOADS EVENLY DISTRIBUTED AND AS LOW AS POSSIBLE. IT IS IMPORTANT TO NOTE THAT THE KARGO MASTER RACK LOAD BEARING CAPACITY OF 1700 LBS. MAY BE GREATER THAN YOUR TRUCK'S GAWR OR GVWR CAPACITY, AND IS PROBABLY GREATER THAN THE WEIGHT THAT CAN BE SAFELY CARRIED OVERHEAD. RETIGHTEN ALL BOLTS AFTER FIRST USE, PERIODICALLY CHECK BOLTS FOR TIGHTNESS.