

JONES

Racing Products

2015

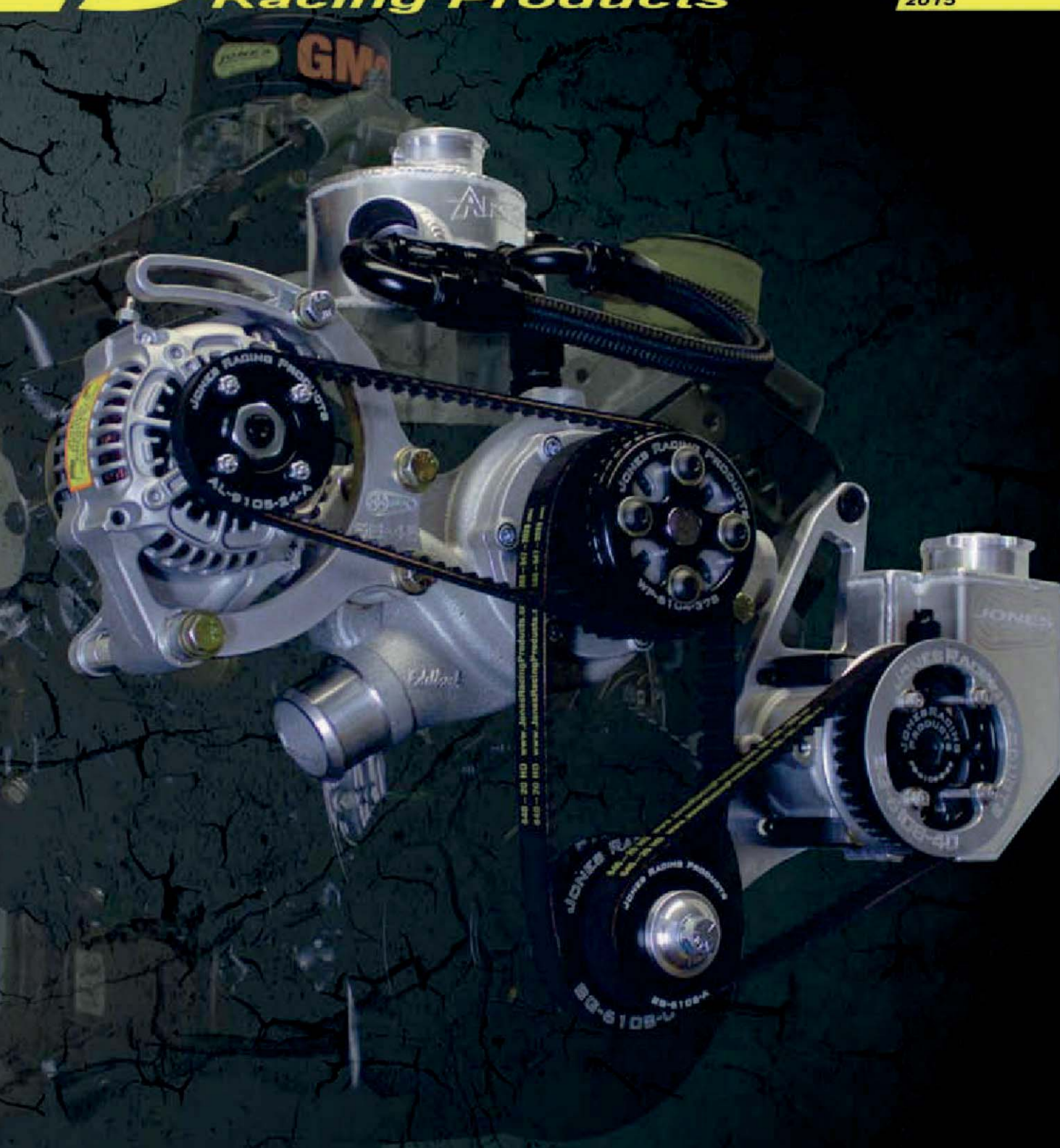

800-541-3888
www.JonesRacingProducts.com
440-200-800

WHAT DRIVES YOU!®

Crankshaft Hubs & Pulleys	4-9
Drive Mandrels and Drive Hubs	4
Split-V Drive Hubs & Drive Hub Spacers & Accessories	5
Radius Tooth HTD Crankshaft Pulleys	6
Square Tooth Gilmer Crankshaft Pulleys	7
Serpentine Poly-V (Micro-V) Crankshaft Pulleys	8
V-Belt Crankshaft Pulleys	9
Alternators & Accessories	10-13
Lightweight Aluminum Alternators	10
Alternator Pulleys	11
Alternator Brackets	12
Power Steering Pumps & Accessories	13-15
Aluminum Power Steering Pumps, Reservoirs & PS Fluid	13
Power Steering Pump Pulleys	14
Power Steering Pump Brackets	15
Fuel & Tandem Pump, Pump Pulleys & Brackets	16
Vacuum Pumps, Pulleys, Brackets & Accessories	17
Dry Sump Oil Pumps & Accessories	18-19
Dry Sump Oil Pumps, Brackets & Accessories	18
Dry Sump Oil Pump Pulleys, Guides & Accessories	19
Water Pumps & Accessories	20-23
Water Pumps, Restrictors, Shims, Spacers & Bushings	20
Expansion Tanks	21
Radius Tooth, Square Tooth & Serpentine WP Pulleys	22
V-Belt Water Pump Pulleys	23
Accessories	24-26
Belt Guides	24
AN Wrenches, Spark Plug Tools, & Engine Storage Accessories	25
AN Fittings, AN Line, and Support Coil	26

Complete Drive Kits

Stand-Alone Water Pump Belt Drives	27-29
LS Serpentine Stand-Alone Water Pump Drive & LS WP PS & Alt Kit	27
SB Chevy, Ford & Chrysler Stand-Alone Water Pump Serpentine Drives ..	28
SBC 602 & 604 Crate Engine Drives	29
Serpentine Water Pump & Power Steering Belt Drives	29-33
SB Chevy Serpentine Water Pump & Power Steering Drive	29-30
SB Ford Serpentine Water Pump & Power Steering Drive	31
SB Chrysler Serpentine Water Pump & Power Steering Drive	32
BBC Serpentine Water Pump, Power Steering & Alternator Drive	33
Radius Tooth HTD Drive Kits	34-35
SB Chevy, or Ford Water Pump Drive	34
SB Chevy, Water Pump & Oil Pump Drive	34
Bell Housing Mounted Oil, PS, Tandem Pump or Alternator Drives	35
Water Pump, Power Steering, Oil Pump & Alternator Drive System	36-39
SBC Serpentine Stand-Alone Water Pump & WP to PS, Radius Tooth Crank to Oil Pump & WP to Alternator Drive	36
BBC Serpentine Stand-Alone Water Pump & WP to PS, Radius Tooth Crank to Oil Pump & WP to Alternator Drive	37
SBC Asphalt Late model Radius Tooth CS to WP & WP to PS, WP to Alt & CS to OP	38
SBC NASCAR Modified Radius Tooth CS to WP & WP to PS, WP to Alt & CS to OP	39
Tandem Pump (Fuel & Power Steering Pump Drive)	40
SBC Belt Driven Cam Drive, Runs in Oil Under Stock Cover	41
Complete Alternator Kits	42-46
SBC Complete Alternator Kits	42-44
SB Ford Complete Alternator Kits	45
SB Chrysler Complete Alternator Kits	46
BBC Complete Alternator Kits	47
Motorplate & Rear Mount Alternator Kits	48
Street Smart Serpentine Complete Kit	49
Belts	50

Kit Finder

Kit # & Page # Accessory Engine Type	WP Drive	WP & PS	WP & PS & AL	WP, PS, OP & AL	Fuel Pump	Oil Pump	Alternator	Street
SB Chevy	1020-S ...28 1035-S ...29 2010-RA .34	1020-PS..... 28 1004-AR-CE..30	2441-AR-CE..29 1441-AR-CE..30	1056-S 36 4-4698-R 38 4-4698-RMP..39	2001-RA ...40	2015-RA ..34 2002-RA ..34	See Pages 42, 43 & 44	See Pages 29, 30, 49
SB Ford	1026-S ...28 2010-F ...34	1005-S-CE ..31	1565-AR-CE..31	1057-S 36	2001-F40	2002-F ..34	See Page 45	See Pages 31 & 49
SB Chry	1028-S ...28	1008-S-CE ..32	1875-65 ...32		2001-CR ...40		See Page 46	See Pages 32 & 49
BB Chevy	1020-S ...28 2010-RA-BB .34	1065-S33	1065-S33	1055-S ...37	2001-BB ...40	2002-BB ..34	See Page 47	See Pages 33 & 49
Bell Housing		PS Only 2004-PS35			2001-BH ...40	2004-RA ..35	2004-AL ..35	
LS (CT525)	1020-LS ..27	1006-LS ..27	1646-LS ..27		2003-LS ..27	2002-LS-R .34 2002-LS-L .34	2046-LS ..27	

SMALL BLOCK CHEVY

DH-8101-NE-A-2.5"
DH-8101-NE-B-3.5"
DH-8101-NE-C-4.0"
 Billet aluminum **SBC** drive hub
 Slides inside of balancer
 Built-in nut to turnover engine
 2.5" has a built-in spacer
 to align with "C" wp pulley



DH-8101-WC-SB
 SBC Billet aluminum drive hub
 Mounts to chevy balancer
 uses self-contained end bolt-
 kit: **BEC-2109-HC**



DH-8101-ADP-SB
 SBC Register



DH-8101-A (SB) & DH-8101-B (BB)
 Billet aluminum Chevy drive hubs
 Uses DHM thread-in mandrel
 Fits inside of balancer



DH-8101-C & DH-8101-C-BB
 Billet aluminum **SB** or **BBC** DHM
 thread-in mandrel hub, Bolts to
 balancer face via kit **SK-2109-DK**



DH-8101-C-DP & DH-8101-BB-DP
 Aluminum SB or BBC drive hubs
 dual dowel pin design. Bolts to
 balancer face via **SK-2109-DK**



THREAD-IN MANDRELS, 1/8" KEYWAY



DHM-8101-A 1.062" Long x 1-1/8" O.D.
DHM-8101-B 3.500" Long x 1-1/8" O.D.
DHM-8101-C 4.000" Long x 1-1/8" O.D.
DHM-8101-D 4.500" Long x 1-1/8" O.D.
DHM-8101-E 5.000" Long x 1-1/8" O.D.
DHM-8101-F 5.500" Long x 1-1/8" O.D.
DHM-8101-G 4.000" Long x 1" O.D.

CHRYSLER/MOPAR



DH-8101-WC-C
 Chrysler 6-bolt drive hub
 3/8 & 5/16 6-bolt pattern
 uses self-contained end
 bolt kit: **BEC-2109-HC**
 Use with mounting kit
DH-2109-BC

BIG BLOCK CHEVY



DH-8101-WC-BB
 Billet aluminum drive hub
 Mounts to **BBC** balancer
 Self-contained end bolt-
 kit: **BEC-2109-HC**
 Use with mounting kit
DH-2109-BC

DH-8101-WC-DE
 (3.25" long from balancer to tip)
DH-8101-WC-SR
 (3.917" long from balancer to tip)
DH-8101-WC-SR-A
 (4.168" long from balancer to tip)
BBC & SBF 3-Bolt Pattern
 Self-contained end bolt
 Bolts to balancer face
 features built-in spacer



DURAMAX DIESEL



DH-8101-WC-DD
 Billet aluminum
 drive hub, mounts to
 Duramax Super Dampers
 end bolt: **BEC-2109-HC**

SB & BB FORD



DH-8101-WC-F3 (3-Bolt)
DH-8101-351-F4 (4-Bolt)
 Billet aluminum drive hub, mounts to
 SBF balancer, uses self-contained
 end bolt: **BEC-2109-HC**
 Use with mounting kit
DH-2109-BC



DH-8101-WC-F4-460
 Billet aluminum drive hub
 Mounts to BBF balancer
 Cut to clear large balancer bolt
 uses self-contained end bolt-
 kit: **BEC-2109-F4**
 Use with mounting kit
DH-2109-BC



Mandrel Nut (To turn over engine)



CSN-6103-A (1-1/8" mandrel)
CSN-6103-B (1" mandrel)

ADAPTERS: CHEVY SB TO BB & CHEVY TO FORD

DH-8101-ADP-SB (BBC DH to SBC Bal. Adapter)
DH-3102-ADP (SBC to BBC Bal. Adapter)
DH-3102-F3-ADP (3-Bolt BBC to 3-Bolt Ford Bal.)

BBC DH to SBC SBC DH to BBC Balancer Chevy to Ford 3-Bolt

SPLIT-V DRIVE HUBS

Mounts CS-3102-WC V-Belt pulleys
 BBC bolt pattern and register
 Use **DH-8101-ADP-SB** for SBC
 Use w/ **DHS-3102-SK-BC** Shim kit

DH-3102-A for 1 Split-Vs
DH-3102-B for 2 Split-Vs
DH-3102-D for 3 Split-Vs
DH-3102-C for 4 Split-Vs



DH-3102 Split-V Spacer



DHS-3102-1/4"
DHS-3102-3/8"
DHS-3102-1/2"
DHS-3102-3/4"

DHS-3102-SK-B
 6- .020 Shim
DHS-3102-SK-C
 1- .060 Shim
DHS-3102-SK-BC
 2- .060 Shim & 6 - .030 Shims



DRIVE HUB SPACERS

an "A" signifies an 1-1/8" Inside Diameter

a "B" signifies an 1" Inside Diameter

SP-6103-G- (A or B) 1/16" Thick
SP-6103-A- (A or B) 1/4" Thick
SP-6103-B- (A or B) 3/8" Thick
SP-6103-C- (A or B) 1/2" Thick
SP-6103-D- (A or B) 3/4" Thick
SP-6103-E- (A or B) 1.0" Thick
SP-6103-F- (A or B) 1-1/4" Thick
SP-6103-K- (A or B) Spacer Assortment

SP-6103-WC-A Dual-Dowel 1/4" Thick
SP-6103-WC-B Dual-Dowel 3/8" Thick
SP-6103-WC-C Dual-Dowel 1/2" Thick
SP-6103-WC-D Dual-Dowel 3/4" Thick
SP-6103-WC-E Dual-Dowel 1.0" Thick
SP-6103-WC-F Dual-Dowel 1-1/4" Thick
SP-6103-WC-K Dual-Dowel Spacer Assortment



SBC Register

SP-3102-SB-1/4"
SP-3102-SB-3/8"
SP-3102-SB-1/2"
SP-3102-SB-3/4"

BBC Register

SP-3102-BB-1/4"
SP-3102-BB-3/8"
SP-3102-BB-1/2"
SP-3102-BB-3/4"

DRIVE HUB BOLT KITS

7/16 Through Bolts (Fine, SAE):

BEC-2109-2.5" 2.5" Long
BEC-2109-A 4.0" Long
BEC-2109-B 4.5" Long
BEC-2109-C 5.0" Long
BEC-2109-D 5.5" Long
BEC-2109-E 6.0" Long
BEC-2109-F 6.5" Long
BEC-2109-G 7.0" Long

1/2 Through Bolts (Fine, SAE):

BEC-2109-H 4.0" Long
BEC-2109-I 4.5" Long
BEC-2109-J 5.0" Long
BEC-2109-K 5.5" Long
BEC-2109-L 6.0" Long
BEC-2109-M 6.5" Long
BEC-2109-N 7.0" Long

1/2 Bolts for 1-pc Mandrels, USS

BEC-2109-HC 4.0" Long
BEC-2109-IC 3.0" Long
BEC-2109-JC 2.5" Long
BEC-2109-KC 2.5" Long
BEC-2109-LC 2.0" Long

USS Coarse Thread

SK-2109-A-3/8"x3/4" USS
SK-2109-C-3/8" x 1" USS
SK-2109-D-3/8x1.25" USS
SK-2109-E-3/8x1.5" USS
SK-2109-E-5/16x1.25" USS
SK-2109-F-3/8x1.75" USS
SK-2109-G-3/8x1.75" USS
SK-2109-H-3/8x2.5" USS
SK-2109-I-3/8"x3" USS
 SAE Fine Thread
SK-2109-J-3/8"x1" SAE
SK-2109-K-3/8x1.25" SAE

Flat Head Allen Bolts:



DRIVE HUB END CAPS

Standard End caps

EC-6111-A (7/16 ID for 1-1/8" Mandrel)
EC-6111-B (1/2 ID for 1-1/8" Mandrel)
EC-6111-C (7/16 ID for 1" Mandrel)
EC-6111-D (1/2 ID for 1" Mandrel)

End cap for dual dowel pin

EC-6111-WC-1/2" (1/2 I.D.)
EC-6111-WC-7/16" (7/16 I.D.)

EC-6111-WC-N-1/2" (1/2 I.D.)
EC-6111-WC-N-7/16" (7/16 I.D.)

End cap with built-in nut to turn over engine. For use with dual dowel pin assemblies

Mandrel Nut (to turn over engine)

CSN-6103-A (1-1/8" I.D.)
CSN-6103-B (1" I.D.)



KEYS & PINS

DP-2109-A

(2: 3/4" Long, 3/16" Dowel Pins)

RP-2109-C

(2: 1" Long, 3/16" Roll Pins)

3/16" Woodruff key

WK-2109-A (1/2 Moon Woodruff Key)

3/16" Keyways for OP Pulleys

KS-2109-A (1" Long, 3/16" Keyway)

1/8" Keyways for CS Pulleys

KS-2109-B (1" Long, 1/8" Keyway)

KS-2109-C (3/4" Long, 1/8" Keyway)

KS-2109-D (1/2" Long, 1/8" Keyway)



RADIUS TOOTH HTD CRANKSHAFT PULLEYS (20MM)

1" Wide, 1 1/8" I.D. with 1/8 Keyway
Wider design for ease of belt alignment

- CS-6102-A-17 (17 teeth) (See .830 wide for 29 teeth)
- CS-6102-A-18 (18 teeth) **CS-6102-A-30** (30 teeth)
- CS-6102-A-19 (19 teeth) **CS-6102-A-31** (31 teeth)
- CS-6102-A-20 (20 teeth) (See .830 wide for 32-36 teeth)
- CS-6102-A-21 (21 teeth) **CS-6102-A-37** (37 teeth)
- CS-6102-A-22 (22 teeth) **CS-6102-A-38** (38 teeth)
- CS-6102-A-23 (23 teeth) (See .830 wide for 40 teeth & up)
- CS-6102-A-24 (24 teeth)
- CS-6102-A-25 (25 teeth)
- CS-6102-A-26 (26 teeth)
- CS-6102-A-27 (27 teeth)
- CS-6102-A-28 (28 teeth)



1" Wide, 1" I.D. with 1/8 Keyway
Wider design for ease of belt alignment

- CS-6102-B-17 (17 teeth) **CS-6102-B-25** (25 teeth)
- CS-6102-B-18 (18 teeth) **CS-6102-B-26** (26 teeth)
- CS-6102-B-19 (19 teeth) **CS-6102-B-27** (27 teeth)
- CS-6102-B-20 (20 teeth)
- CS-6102-B-21 (21 teeth)
- CS-6102-B-22 (22 teeth)
- CS-6102-B-23 (23 teeth)
- CS-6102-B-24 (24 teeth)



.830" Wide, 3/16" Dual Dowel Pin Design

- CS-6102-WC-22 (22 teeth)
- CS-6102-WC-23 (23 teeth)
- CS-6102-WC-24 (24 teeth)
- CS-6102-WC-25 (25 teeth)
- CS-6102-WC-26 (26 teeth)



.830" Wide, 1 1/8" I.D. with 1/8 Keyway

- CS-6102-AS-17 (17 teeth) **CS-6102-AS-32** (32 teeth)
- CS-6102-AS-18 (18 teeth) **CS-6102-AS-33** (33 teeth)
- CS-6102-AS-19 (19 teeth) **CS-6102-AS-34** (34 teeth)
- CS-6102-AS-20 (20 teeth) **CS-6102-AS-35** (35 teeth)
- CS-6102-AS-21 (21 teeth) **CS-6102-AS-36** (36 teeth)
- CS-6102-AS-22 (22 teeth) **CS-6102-AS-37** (37 teeth)
- CS-6102-AS-23 (23 teeth) **CS-6102-AS-38** (38 teeth)
- CS-6102-AS-24 (24 teeth) **CS-6102-AS-40** (40 teeth)
- CS-6102-AS-25 (25 teeth) **CS-6102-AS-44** (44 teeth)
- (See 1" wide for 26 teeth) **CS-6102-AS-45** (45 teeth)
- CS-6102-AS-27 (27 teeth)
- (See 1" wide for 28 teeth)
- CS-6102-AS-29 (29 teeth)
- CS-6102-AS-30 (30 teeth)
- CS-6102-AS-31 (31 teeth)



.830" Wide, 1" I.D. with 1/8 Keyway

- CS-6102-BS-17 (17 teeth) **CS-6102-BS-32** (32 teeth)
- CS-6102-BS-18 (18 teeth) **CS-6102-BS-30** (30 teeth)
- CS-6102-BS-19 (19 teeth) **CS-6102-BS-33** (33 teeth)
- CS-6102-BS-20 (20 teeth) **CS-6102-BS-34** (34 teeth)
- CS-6102-BS-21 (21 teeth) **CS-6102-BS-36** (36 teeth)
- CS-6102-BS-22 (22 teeth) **CS-6102-BS-38** (38 teeth)
- CS-6102-BS-23 (23 teeth)
- CS-6102-BS-24 (24 teeth)
- CS-6102-BS-30 (30 teeth)
- CS-6102-BS-31 (31 teeth)



3/16" Dowel for Dual Dowel Pin Assemblies

DP-2109-A (Set of two Dowel Pins)



RADIUS TOOTH HTD CRANKSHAFT PULLEYS (10MM)

.500" Wide, 1 1/8" I.D. with 1/8 Keyway

- CS-6102-AC-17 (17 teeth) **CS-6102-AC-35** (35 teeth)
- CS-6102-AC-18 (18 teeth) **CS-6102-AC-36** (36 teeth)
- CS-6102-AC-19 (19 teeth) **CS-6102-AC-37** (37 teeth)
- CS-6102-AC-20 (20 teeth) **CS-6102-AC-38** (38 teeth)
- CS-6102-AC-21 (21 teeth) **CS-6102-AC-40** (40 teeth)
- CS-6102-AC-22 (22 teeth) **CS-6102-AC-45** (45 teeth)
- CS-6102-AC-23 (23 teeth)
- CS-6102-AC-24 (24 teeth)
- CS-6102-AC-25 (25 teeth)
- CS-6102-AC-32 (32 teeth)



3/16" Dowel for Dual Dowel Pin Assemblies

DP-2109-A (Set of two Dowel Pins)



.500" Wide, 1" I.D. with 1/8 Keyway

- CS-6102-BC-17 (17 teeth) **CS-6102-BC-25** (25 teeth)
- CS-6102-BC-18 (18 teeth) **CS-6102-BC-33** (33 teeth)
- CS-6102-BC-19 (19 teeth) **CS-6102-BC-34** (34 teeth)
- CS-6102-BC-20 (20 teeth) **CS-6102-BC-35** (35 teeth)
- CS-6102-BC-21 (21 teeth)
- CS-6102-BC-22 (22 teeth)
- CS-6102-BC-23 (23 teeth)
- CS-6102-BC-24 (24 teeth)



.500" Wide, 3/16" Dual Dowel Pin

- CS-6102-WC-C-22 (22 teeth)
- CS-6102-WC-C-23 (23 teeth)
- CS-6102-WC-C-24 (24 teeth)



CRANKSHAFT PULLEY BELT GUIDES



1/16" Belt Guides

- BG-6108-F (1 1/8" ID, for 17-22 tooth Pulleys)
- BG-6108-G (1" ID, for 17-22 tooth Pulleys)
- BG-6108-A (1 1/8" ID, for 17-25 tooth Pulleys)
- BG-6108-B (1" ID, for 17-25 tooth Pulleys)
- BG-6108-C (1 1/8" ID, for 26-35 tooth Pulleys)
- BG-6108-D (1" ID, for 26-35 tooth Pulleys)
- BG-6108-E (1 1/8" ID, for 35-40 tooth Pulleys)
- BG-6108-H (1" ID, for 35-40 tooth Pulleys)



1/16" Dual Dowel Belt Guide

BG-6108-WC
(Dual Dowel Design
22-25 tooth Pulleys)

(see page 24 for dimensions)

SQUARE TOOTH GILMER CRANKSHAFT PULLEYS (1-1/16")

1 1/16" Wide, 1 1/8" I.D. with 1/8 Keyway

- CS-4102-A-12 (12 teeth)
- CS-4102-A-14 (14 teeth)
- CS-4102-A-15 (15 teeth)
- CS-4102-A-16 (16 teeth)
- CS-4102-A-17 (17 teeth)
- CS-4102-A-18 (18 teeth)
- CS-4102-A-19 (19 teeth)
- CS-4102-A-20 (20 teeth)
- CS-4102-A-21 (21 teeth)
- CS-4102-A-22 (22 teeth)
- CS-4102-A-26 (26 teeth)



1 1/16" Wide, 1" I.D. with 1/8 Keyway

- CS-4102-B-12 (12 teeth)
- CS-4102-B-14 (14 teeth)
- CS-4102-B-15 (15 teeth)
- CS-4102-B-16 (16 teeth)
- CS-4102-B-17 (17 teeth)
- CS-4102-B-18 (18 teeth)
- CS-4102-B-19 (19 teeth)
- CS-4102-B-20 (20 teeth)
- CS-4102-B-21 (21 teeth)
- CS-4102-B-26 (26 teeth)



1 1/16" Wide, 3/16" Dual Dowel Pin Design

- CS-4102-WC-16 (16 teeth)
- CS-4102-WC-18 (18 teeth)
- CS-4102-WC-19 (19 teeth)
- CS-4102-WC-20 (20 teeth)



3/16" Dowel for Dual Dowel Pin Assemblies

DP-2109-A (Set of two Dowel Pins)



SQUARE TOOTH GILMER CRANKSHAFT PULLEYS (5/8")

9/16" Wide, 1 1/8" I.D. with 1/8 Keyway

- CS-4102-AC-14 (14 teeth)
- CS-4102-AC-15 (15 teeth)
- CS-4102-AC-16 (16 teeth)
- CS-4102-AC-17 (17 teeth)
- CS-4102-AC-18 (18 teeth)
- CS-4102-AC-19 (19 teeth)
- CS-4102-AC-20 (20 teeth)



9/16" Wide, 1" I.D. with 1/8 Keyway

- CS-4102-BC-12 (12 teeth)
- CS-4102-BC-14 (14 teeth)
- CS-4102-BC-15 (15 teeth)
- CS-4102-BC-16 (16 teeth)
- CS-4102-BC-17 (17 teeth)
- CS-4102-BC-18 (18 teeth)
- CS-4102-BC-19 (19 teeth)
- CS-4102-BC-20 (20 teeth)



9/16" Wide, 3/16" Dual Dowel Pin

- CS-4102-WC-C-16 (16 teeth)
- CS-4102-WC-C-18 (18 teeth)
- CS-4102-WC-C-19 (19 teeth)
- CS-4102-WC-C-20 (20 teeth)



3/16" Dowel for Dual Dowel Pin Assemblies

DP-2109-A (Set of two Dowel Pins)



CRANKSHAFT PULLEY BELT GUIDES

1/16" Wide Belt Guides

- BG-6108-F (1 1/8" ID, for 12-20 Square Pulleys)
- BG-6108-G (1" ID, for 12-21 Square Pulleys)
- BG-6108-A (1 1/8" ID, for 12-20 Square Pulleys)
- BG-6108-B (1" ID, for 12-21 Square Pulleys)
- BG-6108-C (1 1/8" ID, for 22-30 Square Pulleys)
- BG-6108-D (1" ID, for 22-30 Square Pulleys)



1/16" Dual Dowel Belt Guide

BG-6108-WC
(Dual Dowel Design
16-20 Square tooth
Pulleys)



(see pg 24 for belt guide dimensions)

Billet Alum. Gilmer Crankshaft Pulleys

SERPENTINE POLY-V CRANKSHAFT PULLEYS (5 OR 6PK)**6-Groove, 1" wide, 1 1/8" I.D. with an 1/8 key****1 extra groove for ease of belt alignment or for use with a 6PK belt in extreme applications**

CS-5102-AA	2.00" Diameter
CS-5102-A	2.50" Diameter
CS-5102-B	2.80" Diameter
CS-5102-C	3.00" Diameter
CS-5102-D	3.25" Diameter
CS-5102-E	3.50" Diameter
CS-5102-F	3.75" Diameter
CS-5102-G	4.00" Diameter
CS-5102-H	4.25" Diameter
CS-5102-I	4.50" Diameter
CS-5102-J	5.00" Diameter
CS-5102-K	5.50" Diameter
CS-5102-M	6.00" Diameter

**6-Groove, 1" wide, 1" I.D., Dual Dowel Design (Can be customized to use w/ a 1" mandrel)****1 extra groove for ease of belt alignment or for use with a 6PK belt in extreme applications**

CS-5102-WC-A	2.50" Diameter
CS-5102-WC-B	2.80" Diameter
CS-5102-WC-C	3.00" Diameter
CS-5102-WC-D	3.25" Diameter
CS-5102-WC-E	3.50" Diameter
CS-5102-WC-F	3.75" Diameter
CS-5102-WC-G	4.00" Diameter
CS-5102-WC-H	4.25" Diameter
CS-5102-WC-I	4.50" Diameter
CS-5102-WC-J	5.00" Diameter
CS-5102-WC-K	5.50" Diameter
CS-5102-WC-M	6.00" Diameter

**DP-2109-A (Set of two)**3/16" Dowels for
Dual Dowel
Pin Assemblies**6-Groove, Direct Bolt-on Crank Pulleys, SBC Register & 3-Bolt Pattern****1 extra groove for ease of belt alignment or for use with a 6PK belt for extreme applications**

DH-5102-G 4.000"
3-Bolt, with BB & SBC
Register. See Kit 1020
Stand-alone WP Drive.

DH-5102-H 4.250"
3-Bolt w. SBC Register
See Kit 1035-S, Stand-
alone Crate WP Drive.

CT-525 4.000"
3-Bolt, with CT525 O.D.
Register, for LS CT525
Stand-alone WP Drive.

DH-3102-F3-ADP
(3-Bolt SBF Balancer to
3-Bolt SBC Hub Adapter)



DH-3102-ADP
Converts SBC to
BBC Register

**SERPENTINE POLY-V BELT TENSIONER & IDLER**

T-5100
Spring-Loaded
Belt Tensioner

**ID-5107 (Pulley) &
IDM-9100 (Mount)**
Idler Pulley Assembly



SPLIT-V CRANKSHAFT PULLEYS

- CS-3102-WC-D (5.20" O.D. Split-V CS Pulley)
- CS-3102-WC-E (5.50" O.D. Split-V CS Pulley)
- CS-3102-WC-F (5.75" O.D. Split-V CS Pulley)
- CS-3102-WC-G (6.00" O.D. Split-V CS Pulley)
- CS-3102-WC-H (6.50" O.D. Split-V CS Pulley)
- CS-3102-WC-I (7.00" O.D. Split-V CS Pulley)



Split-V Shims

- DHS-3102-SK-B (3, .020" Shims)
- DHS-3102-SK-C (1, .060" Shims)
- DHS-3102-SK-BC (2, .060" Shims & 3, .020" Shims)



Split-V Spacers

- DHS-3102-1/4" (1/4" Spacer, Use w/ Split-V Hubs)
- DHS-3102-3/8" (3/8" Spacer, Use w/ Split-V Hubs)
- DHS-3102-1/2" (1/2" Spacer, Use w/ Split-V Hubs)
- DHS-3102-3/4" (3/4" Spacer, Use w/ Split-V Hubs)
- DHS-3102-1" (1" Spacer, Use w/ Split-V Hubs)



(See Page 5 for Split-V Drive Hubs)

V-BELT CRANKSHAFT PULLEYS FOR MANDRELS

- CS-3102-A (3" O.D., 1 1/8" I.D., 1/8" Keyway)
- CS-3102-B (3" O.D., 1" I.D., 1/8" Keyway)
- CS-3102-WC (3" O.D., Dual Dowel Pin Design)
- CS-3102-D-A (4" O.D., 1 1/8" I.D., 1/8" Keyway)
- CS-3102-D-B (4" O.D., 1" I.D., 1/8" Keyway)
- CS-3102-C-A (5" O.D., 1 1/8" I.D., 1/8" Keyway)
- CS-3102-C-B (5" O.D., 1" I.D., 1/8" Keyway)



V-BELT DIRECT BOLT-ON CRANKSHAFT PULLEYS

Double-V-Belt, with Center Threads

to accept DHM Mandrel or Dual Dowel Assem.

3-Bolt Pattern SBC Register

CS-3102-WC-A 5.5" Diameter

CS-3102-WC-B 6" Diameter

Single-V-Belt

3-Bolt Pattern SBC Register

DH-3102-C 5" Diameter

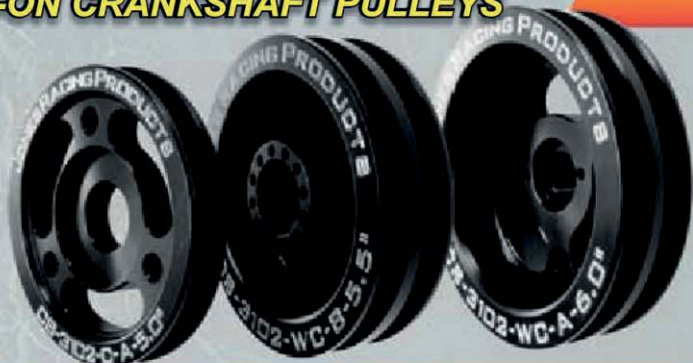

CHEVY SB TO BB ADAPTERS & CHEVY TO FORD ADAPTERS

DH-8101-ADP-SB (BBC to SBC Bal. Adapter)

DH-3102-ADP (SBC to BBC Bal. Adapter)

DH-3102-F3-ADP (3-Bolt SBF Balancer to
3-Bolt BB Chevy Pattern)

BB DH to SBC

SB to BBC

Ford 3-Bolt



35 AMPS AT LOW RPM, 55 MAX, MINI ALTERNATOR, 5 LBS**AL-9101-A-NS**

(1-Wire, Self Exciting, 12v, 40+ amps)

AL-9101-A-A (Adjustable Voltage)

(1-Wire, Self Exciting, adjustable 12v-19v, 40+ amps)

AL-9101-A

(Standard 3-Wire, 12v, 40+ amps)

**45 AMPS AT LOW RPM, 70 MAX, MINI ALTERNATOR, 6 LBS.****AL-9101-B-NS**

(1-Wire, Self Exciting, 12v, 70+ amps)

AL-9101-B-A (Adjustable Voltage)

(1-Wire, Self Exciting, adjustable 12v-19v, 70 amps)

AL-9101-B

(Standard 3-Wire, 12v, 70+ amps)

**65 AMPS AT LOW RPM, 95 MAX, MINI ALTERNATOR, 9 LBS.****AL-9101-C-NS**

(1-Wire, Self Exciting, 12v, 90+ amps)

AL-9101-C-160

(1-Wire, Self Exciting, 12v, max 160 amps)

AL-9101-C-A (Adjustable Voltage)

(1-Wire, Self Exciting, adjustable 12v-19v, 90+ amps)

AL-9101-C

(Standard 3-Wire, 12v, 90+ amps)

**80 AMPS AT LOW RPM, 140 MAX HD ALTERNATOR, 11 LBS.****AL-9101-E-NS**

(1-Wire, Self Exciting, 12v, 140+ amps)

AL-9101-E-A (Adjustable Voltage)

(1-Wire, Self Exciting, adjustable 12v-19v, 135+ amps)

AL-9101-E

(Standard 3-Wire, 12v, 140+ amps)

**120-200 AMP HD ALTERNATOR, 14 LBS.****AL-9101-D-NS**

(1-Wire, Self Exciting, 12v, 90 Idle, 140+ amps)

AL-9101-D-200

(1-Wire, Self Exciting, 12v, max 200 amps)

AL-9101-D-A (Adjustable Voltage)

(1-Wire, Self Exciting, adjustable 12v-19v, 140+ amps)

AL-9101-D

(Standard 3-Wire, 12v, 90 Idle, 140+ amps)



RADIUS TOOTH HTD ALTERNATOR PULLEYS

AL-9105-32

- AL-6105-18-A (18 Tooth, .590, 15mm I.D., 1" Wide)
- AL-6105-22-A (22 Tooth, .590, 15mm I.D., 1" Wide)
- AL-9105-24-A (24 Tooth, .590, 15mm I.D., .45" Wide, w/ Guides)
- AL-9105-32-A (32 Tooth, .590, 15mm I.D., .45" Wide, w/ Guides)



- AL-6105-18-B (18 Tooth, .669, 15mm I.D., 1" Wide)
- AL-6105-22-B (22 Tooth, .669, 15mm I.D., 1" Wide)
- AL-9105-24-B (24 Tooth, .669, 15mm I.D., .45" Wide, w/ Guides)
- AL-9105-32-B (32 Tooth, .669, 15mm I.D., .45" Wide, w/ Guides)

Radius Tooth HTD Alternator Pulley Belt Guides

- BG-9108-A (Bolt-On Belt Guides for 24 Tooth Alternator Pulley)
- BG-9108-C (Bolt-On Belt Guides for 32 Tooth Alternator Pulley)
- BG-6108-18-CAP (Billet Belt Guide for 18 Tooth Alternator Pulley)
- BG-6108-22-CAP (Billet Belt Guide for 22 Tooth Alternator Pulley)



ALTERNATOR DRIVE PULLEYS (MOUNTS IN FRONT OF THE WP PULLEY)

- 32 Tooth, 1/2" Wide
- 28 Tooth, .850" Wide
- 40 Tooth, 1.25" Wide



WP-9104-32



WP-9104-28



WP-6104-40

Drive Pulley
Belt Guide



BG-9108-W

Billet External
Fan



F-9105-GM

SQUARE TOOTH GILMER ALTERNATOR PULLEYS

- AL-9105-20-A (20 Tooth, .590 (15mm) I.D. w/ Guides, 1/2" Wide)
- AL-9105-20-B (20 Tooth, .669 (17mm) I.D. w/ Guides, 1/2" Wide)
- AL-9105-27-A (27 Tooth, .590 (15mm) I.D. w/ Guides, 1/2" Wide)
- AL-9105-27-B (27 Tooth, .669 (17mm) I.D. w/ Guides, 1/2" Wide)



Gilmer Alternator Pulley Belt Guides

- BG-9108-B (Bolt-On Belt Guides for 20 Tooth Alternator Pulley)
- BG-9108-D (Bolt-On Belt Guides for 27 Tooth Alternator Pulley)

SERPENTINE POLY-V ALTERNATOR PULLEYS

- AL-5105-A-A (2.5" O.D., .590 (15mm) I.D. 6-Groove)
- AL-5105-A-B (3.0" O.D., .590 (15mm) I.D. 6-Groove)
- AL-5105-A-C (4.0" O.D., .590 (15mm) I.D. 6-Groove)
- AL-5105-B-A (2.5" O.D., .669 (17mm) I.D. 6-Groove)
- AL-5105-B-B (3.0" O.D., .669 (17mm) I.D. 6-Groove)
- AL-5105-B-C (4.0" O.D., .669 (17mm) I.D. 6-Groove)



SERPENTINE & V-BELT ALT DRIVE PULLEYS

- AL-5104-3.25" (3.25" O.D., 4-Groove Serp.)
- WP-5104-D-4" (4.00" O.D., 6-Groove Serp.)
- WP-3104-A-3.50" (3.50" O.D., V-Belt)



V-BELT ALTERNATOR PULLEYS

.590, 15mm Bore

- AL-3105-A-A (2.375" Dia.)
- AL-3105-A-B (2.500" Dia.)
- AL-3105-A-C (3.000" Dia.)
- AL-3105-A-D (4.500" Dia.)
- AL-3105-A-E (5.000" Dia.)
- AL-3105-A-F (5.500" Dia.)
- AL-3105-A-G (6.000" Dia.)

.669, 17mm Bore

- AL-3105-B-A (2.375" Dia.)
- AL-3105-B-B (2.500" Dia.)
- AL-3105-B-C (3.000" Dia.)
- AL-3105-B-D (4.500" Dia.)
- AL-3105-B-E (5.000" Dia.)
- AL-3105-B-F (5.500" Dia.)
- AL-3105-B-G (6.000" Dia.)



Billet Alum. Alternator Pulleys

SB CHEVY MID-MOUNT ALTERNATOR BRACKETS

Mounts from Short-Water Pump, Mounts on Left or Specify Right-Side if Required

- AL-9100-CL-B (45 amp alt.)
- AL-9100-CL-C (65 & 80 amp)
- AL-9100-CL-GM (GM alt.)
- AL-9100-CL-HM (Rear Support)
- AL-9100-CL-BK (Mounting kit)
- AL-9100-CL-GM-BK (GM Mounting kit)



WPM-9101-C

WPM-9101-A

BB CHEVY MID-MOUNT ALTERNATOR BRACKETS

Mounts from Short-Water Pump, Mounts on Left or Specify Right-Side if Required

- AL-9100-CL-B-BB (45 amp alt.)
- AL-9100-CL-C-BB (65 & 80 amp)
- AL-9100-CL-BM-BB (Rear Support)
- AL-9100-CL-BK-BB (Mounting kit)
- AL-9100-CL-GM (GM alt.)
- AL-9100-CL-GM-MK (GM Mounting kit)

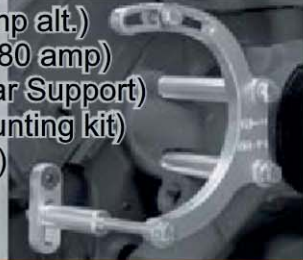

AL-9100-CL-D-BB

WPM-9101-C

SB & BB CHEVY LOW-MOUNT ALTERNATOR BRACKETS

Ideal for use with an Electric WP, *Requires 10.5" from the center of the crank straight out to the frame

SBC & BBC Universal Mid-Mount Passenger Side



EBM-9100-A & MP-9101-C

BBC Universal Lower Driver Side



AL-9101-BB-LM

SBC Universal Lower Driver Side



AL-9101-SB-LM

SB FORD ALTERNATOR BRACKETS



- AL-9100-CL-F-B (45 amp alt.)
- AL-9100-CL-F-C (65 & 80 amp)
- AL-9100-CL-HM-F (Rear Support)
- AL-9100-CL-BK-F (Mounting kit)



AL-9101-F3



AL-9101-HM

SB CHRYSLER ALTERNATOR BRACKETS



- AL-9100-CL-CR-B (45 amp alt.)
- AL-9100-CL-CR-C (65 & 80 amp)
- AL-9100-CL-BM-CR (Rear Support Arm)
- AL-9100-CL-BK-CR (Chrysler Mounting kit)



CH-9101-A

MOTOR PLATE ALTERNATOR BRACKETS



MP-9101-C (universal)

- AL-9100-CL-B (SBC JRP 45 amp)
- AL-9100-CL-C (SBC JRP 65 & 80 amp)
- AL-9100-CL-B-BB (BBC JRP 45 amp)
- AL-9100-CL-C-BB (BBC JRP 65 & 80 amp)



BRAND NEW ALUMINUM POWER STEERING PUMPS



PS-9008-AL
Lightweight Alum Pump
Uses Remote Tank

PS-9008-AL-R
Lightweight Alum Pump
with Integrated 16oz Tank

PS-9008-AL-AR
Lightweight Alum Pump with
Integrated 18oz Alum. Tank
w/ HD Billet Mounting Brackets

POWER STEERING RESERVOIRS



PS-8101-A
Remote Reservoir
For Tubular Frame

PS-8101-B
Remote Reservoir
For Flat Surface

PS-9008-R
16oz Built-in Tank
Attaches to Pump

PS-9008-AR2
18oz Aluminum Tank with
Billet Mounting Ears to
attach the tank to the pump

POWER STEERING FLUID & PULLEY INSTALLER/REMOVAL TOOL

Fully Synthetic Clear Formula. It's clear design makes it easy to see impurities throughout the life of the fluid



PS-9008-16S
PS-9008-32S
PS-9008-1G



PSR-7005-A
Tool to remove and install
press on power steering pulleys

Power Steering Pumps & Tanks

SERPENTINE POWER STEERING PUMP PULLEYS

- PS-5106-B-4.000" Press Fit, 6-Groove Serpentine PS Pulley
 PS-5106-B-4.250" Press Fit, 6-Groove Serpentine PS Pulley
 PS-5106-B-4.500" Press Fit, 6-Groove Serpentine PS Pulley
 PS-5106-B-5.000" Press Fit, 6-Groove Serpentine PS Pulley
 PS-5106-B-5.500" Press Fit, 6-Groove Serpentine PS Pulley
 PS-5106-B-6.000" Press Fit, 6-Groove Serpentine PS Pulley

**V-BELT POWER STEERING PUMP PULLEYS**

- PS-3106-B-4.500" Press Fit, 3/8 or 1/2 V-Belt, PS Pulley
 PS-3106-B-5.000" Press Fit, 3/8 or 1/2 V-Belt, PS Pulley
 PS-3106-B-5.500" Press Fit, 3/8 or 1/2 V-Belt, PS Pulley
 PS-3106-B-6.000" Press Fit, 3/8 or 1/2 V-Belt, PS Pulley
 PS-3106-B-6.500" Press Fit, 3/8 or 1/2 V-Belt, PS Pulley
 PS-3106-B-7.000" Press Fit, 3/8 or 1/2 V-Belt, PS Pulley

**RADIUS TOOTH POWER STEERING PUMP PULLEYS**

- PS-6106-B-33 Press Fit, 33 Tooth, Radius Tooth PS Pulley
 PS-6106-B-40 Press Fit, 40 Tooth, Radius Tooth PS Pulley
 PS-6106-B-45 Press Fit, 45 Tooth, Radius Tooth PS Pulley

- BG-6108-33S Set of 33 Tooth Belt Guide for PS-6106-B-33
 BG-6108-40S Set of 40 Tooth Belt Guide for PS-6106-B-40
 BG-6108-45S Set of 45 Tooth Belt Guide for PS-6106-B-45

**GILMER POWER STEERING PUMP PULLEYS**

- PS-4106-B-28 Press Fit, 28 Tooth, Gilmer PS Pulley
 PS-4106-B-30 Press Fit, 30 Tooth, Gilmer PS Pulley
 PS-4106-B-32 Press Fit, 32 Tooth, Gilmer PS Pulley



SB CHEVY POWER STEERING BRACKETS

Horizontal adjustment for pumps with built-in reservoirs. Low-mount design to maximize belt wrap



PS-8001-SB-R
Mounts to Block & Head

Mounts pump higher to clear oil pump. mid-mount design to clear dry sump.



PS-8001-SB-DS
Mounts to Block & Head

Mounts pump from the driver or passenger-side head



PSH-8001-C
Mounts to Head

Mounts pump from the driver-side head



PSH-8001-SB
Mounts to Head

Reversible



BB CHEVY POWER STEERING BRACKETS

Horizontal adjustment for pumps with a built-in reservoir. Low-mount design to maximize belt wrap



PSL-8001-BB-R
Mounts to Block

Mid-mount for pump with remote reservoir.



PSL-8001-BB
Mounts to Block



VP-9100-BM
Mounts to Block & Head

Mounts pump from the driver or passenger-side head



PSH-8001-BB
Mounts to Head

SB FORD POWER STEERING BRACKETS



PSH-8101-F-R
Head Mount PS Bracket Shown with Mounting Kit PSH-8001-FR-MK

Horizontal Adjustment for Pumps with Built-In Reservoir



PSH-8001-F
Head Mount PS Bracket Shown with Mounting Kit PSH-8001-F-MK

CHRYSLER PS BRACKETS



PSL-8001-C
Mounts to Block & Head

PS-8001-CR-R 
Horizontal Adjustment for pumps w. built-in reservoirs. Low mount design to maximize belt wrap.



MOTORPLATE PS BRACKET



PST-8001-E
Motorplate Bracket

Billet Alum. Power Steering Brackets

KSE TANDEM PUMP



KSE-8009-C
Combination PS & Fuel Pump

BELT DRIVEN FUEL PUMP



FP-8009-A
Belt Driven Fuel Pump

RADIUS TOOTH HTD FUEL PUMP PULLEYS, 1" WIDE

- FP-6106-40-1" 5/8" I.D., 3/16" Key, 1" Wide, 40 Teeth
- FP-6106-42-1" 5/8" I.D., 3/16" Key, 1" Wide, 42 Teeth
- FP-6106-44-1" 5/8" I.D., 3/16" Key, 1" Wide, 44 Teeth
- FP-6106-45-1" 5/8" I.D., 3/16" Key, 1" Wide, 44 Teeth
- FP-6106-48-1" 5/8" I.D., 3/16" Key, 1" Wide, 48 Teeth



RADIUS TOOTH HTD FUEL PUMP PULLEYS, 5/8" WIDE

- FP-6106-36-5/8" 5/8" I.D., 3/16" Key, 5/8" Wide, 36 Teeth
- FP-6106-38-5/8" 5/8" I.D., 3/16" Key, 5/8" Wide, 38 Teeth
- FP-6106-40-5/8" 5/8" I.D., 3/16" Key, 5/8" Wide, 40 Teeth
- FP-6106-44-5/8" 5/8" I.D., 3/16" Key, 5/8" Wide, 44 Teeth



FUEL PUMP PULLEY BELT GUIDES

- BG-6108-36S Billet, Bolt-On Belt Guides for 36 tooth Pulleys
- BG-6108-38S Billet, Bolt-On Belt Guides for 38 tooth Pulleys
- BG-6108-40S Billet, Bolt-On Belt Guides for 40 tooth Pulleys
- BG-6108-42S Billet, Bolt-On Belt Guides for 42 tooth Pulleys
- BG-6108-44S Billet, Bolt-On Belt Guides for 44 tooth Pulleys
- BG-6108-45S Billet, Bolt-On Belt Guides for 45 tooth Pulleys
- BG-6108-48S Billet, Bolt-On Belt Guides for 48 tooth Pulleys



FUEL PUMP ACCESSORIES

- FP-7100-6 -6 in-line Fuel Filter, 100 Micron Filter
- FP-7100-8 -8 in-line Fuel Filter, 100 Micron Filter
- FP-7100-10 -10 in-line Fuel Filter, 100 Micron Filter
- FP-7100-12 -12 in-line Fuel Filter, 100 Micron Filter
- FP-8009-R Billet Return Bypass Fuel Regulator
- FP-8009-S Fuel Shut-Off to Pump w/ Swiveling Union
- FP-7100-F Replacement Stainless Steel Filter



FUEL PUMP BRACKETS

SB Chevy



FP-9100-C

SB/BB Chevy



FP-9100-E

SB Ford



FP-9100-A

Chrysler



FP-9100-F

Bell Housing Mount



FP-9100-BH



2001-RA
Up Front Fuel Pump Drive
Drives from WP or Crank

VACUUM PUMPS

Billet Aluminum Pumps, with Built-In Brackets and Machined in AN fittings

2 Stage, Gear Style Vacuum Pump



VP-9100-B
Left Side Vacuum Pump

2 Stage, Gear Style Vacuum Pump



VP-9100-B
Right Side Vacuum Pump

2 Stage, Gear Style Vacuum Pump with a 1 Stage External Wet Sump



VP-9100-WS
Right Side Vacuum Pump

VACUUM PUMP ACCESSORIES

Internal Support Coil, prevents vacuum line from sucking shut. Offers added support necessary for maximum efficiency.



AN-1000-SC
-10 Internal Support Coil
AN-1200-SC
-12 Internal Support Coil
AN-1600-SC
-16 Internal Support Coil

Adjustable Vacuum regulator, Mounts to valve cover.



AN-0800-R2
AN-0800-F (Air Filter)

Vacuum Pump Breather Tank. 2 Inlets, one for vacuum pump exhaust, one for the regulator. With petcock to drain.



VP-9106-A

VACUUM PUMP BRACKETS

SBC Head Mount, Left or Right Side



PSH-8001-C

BBC Head Mount, Left Side



VP-9100-TM

BBC Block Mount, Left or Right Side



VP-9100-BM

BELT GUIDES

(Re-Usable, Bolt on Billet Guides)

- BG-6108-36S**
36 Teeth Guides
- BG-6108-38S**
38 Teeth Guides
- BG-6108-40S**
40 Teeth Guides
- BG-6108-44S**
44 Teeth Guides



VACUUM PUMP PULLEYS

5/8" Wide with 3/16 Keyway & Set Screws

- FP-6106-36-5/8"** 36 Teeth
- FP-6106-38-5/8"** 38 Teeth
- FP-6106-40-5/8"** 40 Teeth
- FP-6106-44-5/8"** 44 Teeth



VACUUM PUMP PULLEYS

For 3-Bolt Hub Design

- VP-6106-36-M**
1/2" Wide, 36 Teeth
- VP-6106-40-M**
1/2" Wide, 40 Teeth



Vacuum Pumps & Accessories

DRY SUMP OIL PUMPS

ARE DRY SUMP SYSTEMS
WWW.DRYSUMP.COM

Billet Aluminum Pumps, with Built-In Bracket and AN fittings Machined into Housing

- OP-8103-1** External Wet Sump Oil Pump
Left Side Mount, SB/BB Chevy
- OP-8103-3** 3 stage Dry Sump Oil Pump
Left Side Mount, SB/BB Chevy
- OP-8103-4** 4 stage Dry Sump Oil Pump
Left Side Mount, SB/BB Chevy
- OP-8103-5** 5 stage Dry Sump Oil Pump
Left Side Mount, SB/BB Chevy

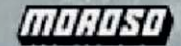

BILLET ALUMINUM OIL PUMP BRACKETS

3/4" Thick Aluminum Oil Pump Brackets

SB Chevy, Mounts next to Balancer
Offers 3 Different Mounting Positions

OP-9101-A



SB Chevy, Mounts next to Balancer
Raised Oil Pump Up and out for frame clearance

OP-9101-A2



SB Ford, Mounts on the Lower
Passenger Side from the
Timing Cover

OP-9101-B

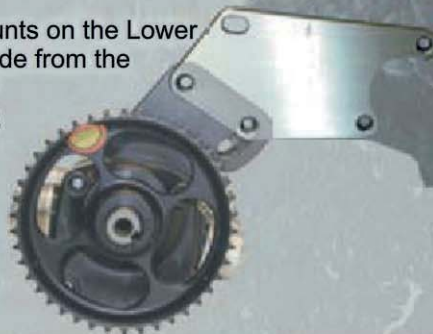

OIL PUMP ACCESSORIES

Internal Support Coil offers added support necessary for maximum efficiency from your scavenge and vacuum lines.



- AN-1000-SC**
-10 Internal Support Coil
- AN-1200-SC**
-12 Internal Support Coil
- AN-1600-SC**
-16 Internal Support Coil

Remote breather/oil separator. Comes with -12 an fittings, filter and bracket.



VP-9106-A

-16 Return Line Oil Filter



OP-8103-16F

Remote Mount for Oil Filter



OP-8103-F

RADIUS TOOTH HTD OIL PUMP PULLEYS

Lightweight, Billet Aluminum, 5/8" I.D., 3/16" Keyway with 5 Set Screws

OP-6103-28-1 1/4"	1 1/4" Wide, 28 Teeth
OP-6103-30-1 1/4"	1 1/4" Wide, 30 Teeth
OP-6103-32-1 1/4"	1 1/4" Wide, 32 Teeth
OP-6103-33-1 1/4"	1 1/4" Wide, 33 Teeth
OP-6103-34-1 1/4"	1 1/4" Wide, 34 Teeth
OP-6103-35-1 1/4"	1 1/4" Wide, 35 Teeth
OP-6103-36-1 1/4"	1 1/4" Wide, 36 Teeth
OP-6103-37-1 1/4"	1 1/4" Wide, 37 Teeth
OP-6103-38-1 1/4"	1 1/4" Wide, 38 Teeth
OP-6103-40-1 1/4"	1 1/4" Wide, 40 Teeth
FP-6106-42-1"	1" Wide, 42 Teeth
FP-6106-44-1"	1" Wide, 44 Teeth
OP-6103-45-1 1/4"	1 1/4" Wide, 45 Teeth
OP-6103-46-1 1/4"	1 1/4" Wide, 46 Teeth
OP-6103-47-1 1/4"	1 1/4" Wide, 47 Teeth
OP-6103-48-1 1/4"	1 1/4" Wide, 48 Teeth
OP-6103-56-1 1/4"	1 1/4" Wide, 56 Teeth



SQUARE TOOTH GILMER OIL PUMP PULLEYS

Lightweight, Billet Aluminum, 5/8" I.D., 3/16" Keyway with 5 Set Screws

OP-4103-26-SQ 1 1/4"	1 1/4" Wide, 26 Teeth
OP-4103-28-SQ 1 1/4"	1 1/4" Wide, 28 Teeth
OP-4103-30-SQ 1 1/4"	1 1/4" Wide, 30 Teeth
OP-4103-32-SQ 1 1/4"	1 1/4" Wide, 32 Teeth
OP-4103-34-SQ 1 1/4"	1 1/4" Wide, 34 Teeth



REUSABLE, BOLT-ON BELT GUIDES

supplied with 4 allen bolts and allen wrench

BG-6108-33S	Billet, Bolt-On Belt Guides for 33 tooth Pulleys
BG-6108-35S	Billet, Bolt-On Belt Guides for 35 tooth Pulleys
BG-6108-36S	Billet, Bolt-On Belt Guides for 36 tooth Pulleys
BG-6108-37S	Billet, Bolt-On Belt Guides for 37 tooth Pulleys
BG-6108-38S	Billet, Bolt-On Belt Guides for 38 tooth Pulleys
BG-6108-40S	Billet, Bolt-On Belt Guides for 40 tooth Pulleys
BG-6108-42S	Billet, Bolt-On Belt Guides for 42 tooth Pulleys
BG-6108-44S	Billet, Bolt-On Belt Guides for 44 tooth Pulleys
BG-6108-45S	Billet, Bolt-On Belt Guides for 45 tooth Pulleys
BG-6108-48S	Billet, Bolt-On Belt Guides for 48 tooth Pulleys



OIL PUMP PRIMER

OP-6103-PP
(Radius Tooth HTD)

OP-4103-PP
(Square Tooth Gilmer)



LOCKING COLLET

OP-.437 7/16" I.D. Locking Collet
OP-.500 1/2" I.D. Locking Collet
OP-.590 15mm I.D. Locking Collet
OP-.625 5/8" I.D. Locking Collet
Call for Custom Sizes



SMALL BLOCK CHEVY WATER PUMPS

Aluminum, SBC Short Style



EDE-8812 & WP-9104-SBC-AL

Steel, SBC Short Style



WP-9104-SBC-ST

Edelbrock Victor Series Short Style, 2-aux fittings



EDE-8817
EDE-8819

BIG BLOCK CHEVY WATER PUMPS

Edelbrock Victor Series Short Style Water Pump



EDE-8852

Edelbrock Short Style Black Coated Water Pump



EDE-88503

SB FORD WATER PUMPS

Alum. SBF Water Pump



WP-9104-SBF-AL

Edelbrock Victor Series Aluminum Water Pump



EDE-8833

SB CHRYSLER WP

Aluminum Water Pump



EDE-8877
WP-9104-CR-AL

WATER PUMP SPACERS

WP-9104-1/4"-SB or WP-9104-1/4"-BB 1/4" Thick WP Spacers
 WP-9104-3/8"-SB or WP-9104-3/8"-BB 3/8" Thick WP Spacers
 WP-9104-1/2"-SB or WP-9104-3/8"-BB 1/2" Thick WP Spacers



FAN SPACERS



WP-9104-FS-2", 3" & 4"

WATER RESTRICTOR



RR-9104-A

Billet Aluminum water restrictor. Place our restrictor in the water outlet of the radiator to aid in cooling your engine. We guarantee our unique restrictor will lower your water temperature. Do not combine with any other restrictors.

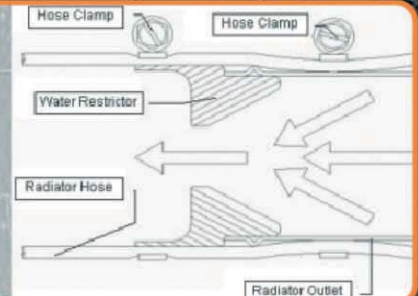

ACCESSORIES

5/8 to 3/4 WP Shaft Adapter



WP-6104-B

Fan Register



WP-6104-C

WP Pulley Spacer



WP-9104-1/2
WP-9104-5/8
WP-9104-3/4

Set of 3 - 1/16" WP Pulleys Shims

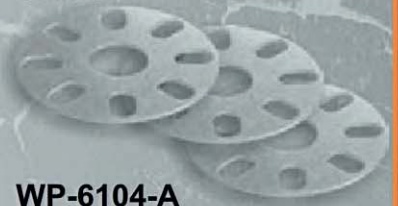

WP-6104-A

MODIFIED EXPANSION TANK



EXT-9104-TM
 Aluminum Construction
 2 Auxiliary Fittings
 -4 Overflow Fitting
 and Bleeder

Mounts to Intake
 (4 Barrel Intake)

EXT-1 1/2"
 Billet Aluminum Hose Snout
 for 1 1/2" Upper Hose



EXT-9104-SK
 Aluminum Construction
 2 Auxiliary Fittings
 -4 Overflow Fitting

Mounts to Intake
 (2 Barrel Intake)

EXT-1 3/4"
 Billet Aluminum Hose Snout
 for 1 3/4" Upper Hose



DIRT MODIFIED EXPANSION TANK



EXT-58037-CBB
 Aluminum
 Construction
 Auxiliary Fitting &
 -4 Overflow Fitting

Mounts to Intake
 Passenger-Side
 1-1/2" Inlet

EXT-58037-L
 Aluminum
 Construction
 2 Auxiliary Fittings
 -4 Overflow Fitting
 and Bleeder

Mounts to Intake
 Passenger-Side
 1-1/2" Inlet



EXPANSION TANK ACCESSORIES

WP-3414-B
 3/4"-NPT Air Bleeder Fitting



WP-1014-B
 AN -10 O-Ring Air Bleeder Fitting

Mounts on top of water pump
 to aid in bleeding the cooling
 system

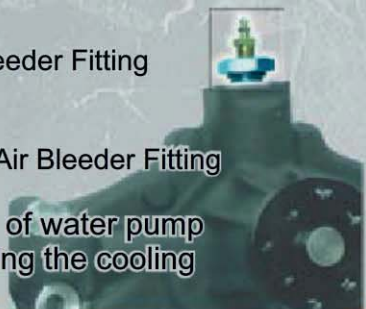

EXT-9104-10
 -10 Braided Line and
 Fittings to run from
 the water pump to
 your expansion tank

RADIUS TOOTH HTD WATER PUMP PULLEYS

Teeth from 0-1.9" Deep



WP-6104-35A 35 Teeth
WP-6104-36A 36 Teeth
WP-6104-37A 37 Teeth

Teeth from 0.15-2.05" Deep



WP-6104-35S 35 Teeth
WP-6104-36S 36 Teeth
WP-6104-37S 37 Teeth
WP-6104-40S 40 Teeth

Teeth from 0.84-2.74" Deep



WP-6104-37-F1 37 Teeth

Teeth from 0-1.250" Deep



WP-6104-40 40 Teeth

GILMER WATER PUMP PULLEYS

Teeth from 0-1.9" Deep



WP-4104-28A 28 Teeth
WP-4104-32A 32 Teeth

Teeth from 1.62-2.05" Deep



WP-4104-28S 28 Teeth
WP-4104-32S 32 Teeth

SERPENTINE, REVERSE ROTATION

1.780" Offset



WP-5104-FS-4
4" Diameter

1.450" Offset



WP-5104-FS-5.5
5.5" Diameter

6-GROOVE SERPENTINE WATER PUMPS PULLEYS

*+.200" or .250" Front Face
0" Mounting Surface*

*Offset is measured
to the center of last V*

.750" Offset



WP-5104-D 4" Diameter

1.25" Offset



WP-5104-C-4" Diameter

WP-5104-C-4.5" Diameter
WP-5104-F 4" Diameter
WP-5104-C-5" Diameter

1.900" Offset



2.395" Offset



WP-5104-WC-4.5" 4.5" Dia.

2.395" Offset



WP-5104-WC-4.5-V
4.5" Dia. Rear Serp,
3 7/8" Front-V

2.395" Offset



WP-5104-WC-5" 5" Dia.

2.115" Offset



WP-5104-WC-5-DS
5" Dia. Rear, 3 7/8" Front Serp.

Offset Measurement Illustration

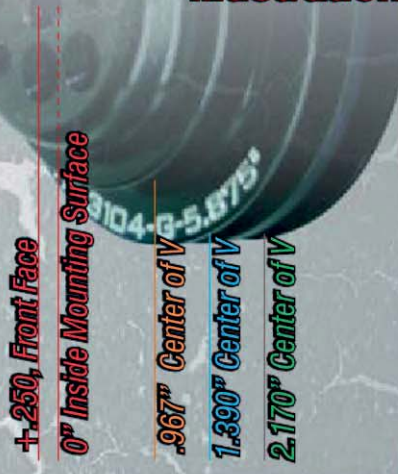

SINGLE-V WATER PUMP PULLEYS

WP-3104-A-6" 6" O.D..
2.170" Offset

WP-3104-A-7" 7" O.D..
2.170" Offset



DOUBLE-V WATER PUMP PULLEYS, (3/8 TO 17/32 WIDE BELT)

WP-3104-J-4.75"
4.75" Diameter
2.400" & 1.800" Offset

WP-3104-B-6"
6" Diameter
2.170" & 1.390" Offset

WP-3104-E-7"
7" Diameter
2.170" & 1.390" Offset



TRIPLE-V WATER PUMP PULLEYS, (3/8 TO 17/32 WIDE BELT)

WP-3104-G
5.875", 2.397" & 1.682"
4.5", .967" Offset

WP-3104-H
7", 2.397" & 1.682" Offset
4.5", .967" Offset

WP-3104-F-7-TV"
7", 2.397", 1.682" &
1.028"



Billet Alum. Water Pump Pulleys

CRANKSHAFT PULLEY BELT GUIDES



1/16" Wide Belt Guides

		Radius Tooth	Square Tooth
BG-6108-F	2.500" O.D., 1.125" I.D.	fits 17-22	fits 12-20
BG-6108-G	2.375" O.D., 1.000" I.D.	fits 17-22	fits 12-19
BG-6108-A	2.625" O.D., 1.125" I.D.	fits 17-25	fits 12-22
BG-6108-B	2.625" O.D., 1.000" I.D.	fits 17-25	fits 12-22
BG-6108-C	3.500" O.D., 1.125" I.D.	fits 26-35	fits 23-28
BG-6108-D	3.500" O.D., 1.000" I.D.	fits 26-35	fits 23-28
BG-6108-E	4.000" O.D., 1.125" I.D.	fits 36-40	fits 28-32
BG-6108-H	4.000" O.D., 1.000" I.D.	fits 36-40	fits 28-32

DUAL DOWEL PIN CRANKSHAFT PULLEY BELT GUIDES



BG-6108-WC 2.625" O.D. fits all Dual Dowel Pulleys

Aluminum removable & reusable belt guide for Dual Dowel, 'WC' crankshaft pulleys. Mounts utilizing the existing two dowel pins connecting the drive assembly. Easy to install and designed to be durable yet lightweight!

OIL PUMP, FUEL PUMP & VACUUM PUMP BOLT-ON BELT GUIDES



- BG-6108-33S** Fits 33 Tooth, Radius Tooth Pulleys
- BG-6108-35S** Fits 35 Tooth, Radius Tooth Pulleys
- BG-6108-36S** Fits 36 Tooth, Radius Tooth Pulleys
- BG-6108-37S** Fits 37 Tooth, Radius Tooth Pulleys
- BG-6108-38S** Fits 38 Tooth, Radius Tooth Pulleys
- BG-6108-40S** Fits 40 Tooth, Radius Tooth Pulleys
- BG-6108-42S** Fits 42 Tooth, Radius Tooth Pulleys
- BG-6108-44S** Fits 44 Tooth, Radius Tooth Pulleys
- BG-6108-45S** Fits 45 Tooth, Radius Tooth Pulleys
- BG-6108-48S** Fits 48 Tooth, Radius Tooth Pulleys

- BG-6108-30SQ** Fits 30 Tooth, Square Tooth Pulleys
- BG-6108-32SQ** Fits 32 Tooth, Square Tooth Pulleys
- BG-6108-34SQ** Fits 34 Tooth, Square Tooth Pulleys

ALTERNATOR PULLEY BELT GUIDES

24 Tooth Alternator Pulley Belt Guides



BG-9108-A

32 Tooth Alternator Pulley Belt Guides



BG-9108-C

18 & 22 Tooth Alt. Pulley Guide



BG-6108-18-CAP
BG-6108-22-CAP

Water Pump Pulley Belt Guide



BG-9108-W
(28-35 Teeth)
BG-9108-E
(35+ Teeth)

1/2" THICK BILLET ALUMINUM AN WRENCHES

- WR-9100-3 -3 An Wrench
- WR-9100-4 -4 An Wrench
- WR-9100-6 -6 An Wrench
- WR-9100-8 -8 An Wrench
- WR-9100-10 -10 An Wrench
- WR-9100-12 -12 An Wrench
- WR-9100-16 -16 An Wrench
- WR-9100-20 -20 An Wrench
- WR-9100-PV-6 -6, Power Valve and Needle & Seat
- WR-9100-PV-8 -6, Power Valve and Needle & Seat



LASER-GUIDED TEMPERATURE GAUGES

Heavy-Duty High Temp Gun



TL-8101-L-HT
0-1000° F

Temp Gun



TL-8101-L
0-525° F

Pocket Temp Gauge



TL-8101-L-HH
0-518° F

Laser guided temperature guns capable of judging temperatures ranging from as cold as -58°F to as hot as 1000°F. Equipped with a backlit digital readout which is able to display the temperature in Celsius or Fahrenheit.

SPARK PLUG TOOLS

Spark Plug Indexer



SP-8101-V8-C

Spark Plug Indexer with rotatable inserts



SP-8101-V8-B

Indexer with rotatable inserts & 9th Hole for easy setup



SP-8101-V8-A

Spark Plug Inspection Tool



SP-8101-IL

Billet aluminum spark plug indexers, available with inserts that rotate to synchronize the threads between the head and tool. Available in an 8-hole or 9-hole design. Use the 9th hole to make indexing your plugs quicker. See our Spark Plug Indexing info sheet for complete directions and the advantages of indexing you spark plugs.

ENGINE STORAGE

Water Outlet Cover



WO-9101-A

Distributor Cover



DE-9101-G



- EX-9101-A SBC Standard Ports
- EX-9101-B SBC Spread Ports
- EX-9101-C BB Chevy
- EX-9101-D SB Ford S.V.O.
- EX-9101-E SB Ford (260-351)
- EX-9101-F SB Ford w/ Dart or TFS

AN HOSE ENDS (SWIVELING HIGH-FLOW DESIGN WITH BLACK FINISH)

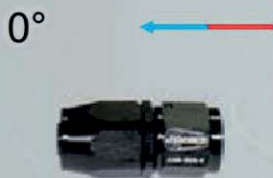

AN Size	Part #
-6	ANB-0600-0
-8	ANB-0800-0
-10	ANB-1000-0
-12	ANB-1200-0
-16	ANB-1600-0
-20	ANB-2000-0

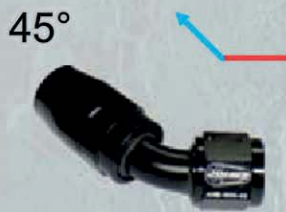

AN Size	Part #
-6	ANB-0600-45
-8	ANB-0800-45
-10	ANB-1000-45
-12	ANB-1200-45
-16	ANB-1600-45
-20	ANB-2000-45

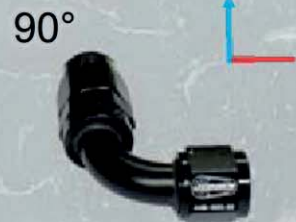

AN Size	Part #
-6	ANB-0600-90
-8	ANB-0800-90
-10	ANB-1000-90
-12	ANB-1200-90
-16	ANB-1600-90
-20	ANB-2000-90



AN Size	Part #
-6	ANB-0600-120
-8	ANB-0800-120
-10	ANB-1000-120
-12	ANB-1200-120
-16	ANB-1600-120
-20	ANB-2000-120



AN Size	Part #
-6	ANB-0600-150
-8	ANB-0800-150
-10	ANB-1000-150
-12	ANB-1200-150
-16	ANB-1600-150
-20	ANB-2000-150

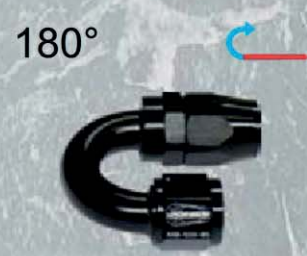

AN Size	Part #
-6	ANB-0600-180
-8	ANB-0800-180
-10	ANB-1000-180
-12	ANB-1200-180
-16	ANB-1600-180
-20	ANB-2000-180

LIGHTWEIGHT BRAIDED HOSE

- ANB-0600-BL : -06 Braided Hose
- ANB-0800-BL : -08 Braided Hose
- ANB-1000-BL : -10 Braided Hose
- ANB-1200-BL : -12 Braided Hose
- ANB-1600-BL : -16 Braided Hose
- ANB-2000-BL : -20 Braided Hose

Lightweight Stainless Steel impregnated Synthetic rubber hose with a lightweight black nylon outer cover.

350-500 PSI Continuous
1400-2000 PSI Burst

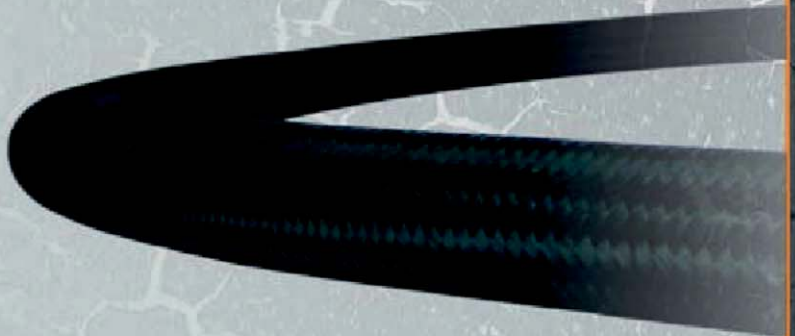

INTERNAL SUPPORT COIL

Internal Support Coil, prevents vacuum line from sucking shut. Offers added support necessary for maximum efficiency.



- AN-1200-SC : -12 Internal Support Coil
- AN-1600-SC : -16 Internal Support Coil

1020-LS LS SERPENTINE WATER PUMP DRIVE



DH-CT525 Crank Pulley
SK-2109-I CS Pulley Bolts
DP-2109-A Dowel Pin set
EC-6111-WC-Nx1/2" End Cap w/ Integrated Billet Nut

WP-5104-C-4.5" Water Pump Pulley
WP-5104-MK WP Pulley Mounting Kit
WP-9104-LS HP LS Water Pump
5PK-698 HD Heavy Duty Belt

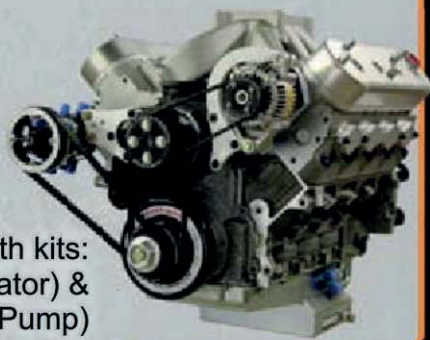

Kit 1020-LS show with kits:
 2046 (Alternator) &
 2002-LS (Tandem PS & Fuel Pump)

1006-LS LS WATER PUMP & POWER STEERING SERPENTINE BELT DRIVE SYSTEM



DH-CT525 Crank Pulley
SK-2109-I CS Pulley Bolts
DP-2109-A Dowel Pin set
EC-6111-WC-N End Cap w/ Integrated Billet Nut

WP-5104-C-4.5" Water Pump Pulley
WP-5104-MK Pulley Mounting Kit
WP-9104-LS HP LS Water Pump

PS-8001-LS-R PS Bracket
PS-9008-AL-AR PS Pump w. Tank
PS-5106-B-5.000" PS Pulley
5PK-890 HD Heavy Duty Belt



Kit 1006 show with kits:
 2046 (Alternator) &
 2003-LS (Fuel Pump)

LS Serpentine Belt Drives

1020-S SMALL BLOCK & BIG BLOCK CHEVY SERPENTINE WATER PUMP DRIVE

Features a one-piece lower pulley further reducing weight while adding strength. This design also features a reversible registering ring making one kit compatible with BB or SB crank snouts.



WP-5104-WC-5"
WP-5104-MK

Water Pump Pulley
Mounting Kit

5PK-695HD

Heavy Duty Belt

DH-5102-G

Crank Pulley, bolts
directly to the balancer.

SK-2109-H2

Flat head Mounting Bolts

DH-5102-R

SB or BB Pulley Register

EC-6111-WC-N

End Cap w/ Integrated
Billet Nut & Crank Bolt



**1020-PS ADD-ON
POWER STEERING KIT**

1026-S SMALL BLOCK FORD SERPENTINE WATER PUMP DRIVE



WP-5104-WC-5"
WP-5104-MK

Water Pump Pulley
Mounting Kit

5PK-690HD

Heavy Duty Belt

DH-8101-WC-DE

Drive Hub

DH-2109-BC

Bolt Kit

CS-5102-G

Crank Pulley

BEC-2109-JC

End Cap & Crank Bolt



EDE-8833

Edelbrock Victor Series
Circle Track Pump

1028-S

Small Block Chrysler
Serpentine Water Pump Drive

Chrysler

1035-S-CE SB CHEVY CRATE ENGINE WATER PUMP DRIVE



WP-5104-WC-4.5"
WP-5104-MK

Water Pump Pulley
Mounting Kit

5PK-690HD

Heavy Duty Belt

DH-5102-H
DH-2109-BC
BEC-2109-A

Crank Pulley
Bolt Kit
End Cap & Bolt

3441-AR-CE SBC 602/604 CRATE ENGINE V-BELT DRIVE SYSTEM



Kit Includes Brand New, Aluminum Short Style Water Pump; Alum. Power Steering Pump with Built-In Tank; & a Mini, Lightweight Aluminum, 1-wire 45-idle / 70-max amp Alternator. Kit also features all Billet Aluminum Pulleys & Brackets, which are supplied with all the necessary Belts, Spare Belts, Mounting Hardware and Spacers.

POPULAR KIT VARIATIONS

3441-AR-CE Complete System
3004-AR-CE CS, WP & PS Only
3004-AL-CE PS for Remote reservoir
3001-CE Water Pump Drive Only

2441-AR-CE SB CHEVY CRATE ENGINE WATER PUMP, POWER STEERING & ALTERNATOR DRIVE



DH-8101-NE-B-2.5" SBC Drive Mandrel
SP-6103-B-A Crank Pulley Spacer
BG-6108-C Belt Guide
CS-3102-AS-33 Radius Tooth CS Pulley
CS-6102-AS-25 Radius Tooth CS Pulley
BG-6108-A Belt Guide
BEC-2109-K Bolt & End Cap Kit

EDE-8827 HP Water Pump
WP-6104-37S Radius Tooth WP Pulley
WP-6104-MK Pulley Mounting Kit
640-20 XHD Extreme Duty Belt
WP-9104-17F-P Polymer L/W Fan
BG-9108-E Fan Shield

PS-9008-AL-AR PS Pump w/ Alum. Tank
PS-6106-B-40 Radius Tooth PS Pulley
BG-6108-40S Belt Guides
PS-8001-SB-R PS Bracket w/ Hardware
640-20 HD Radius Tooth Belt

2041-44698R Radius Tooth Alt. Kit

1004-AR-CE**SMALL BLOCK CHEVY SERPENTINE
WATER PUMP & PS DRIVE SYSTEM**

See our stand alone
water pump drives on pages 28 & 29

DH-8101-NE-A Drive Hub
CS-5102-F Crank Pulley
BEC-2109-G End Cap & Bolt

WP-9104-SBC-AL Alum. HP Water Pump
WP-5104-C Water Pump Pulley
WP-5104-MK Shims & Bushings

PS-8001-SB-R PS Bracket
PS-9008-AL-AR PS Pump with Tank
PS-5106-B-4.5" PS Pulley
5PK-850HD Heavy Duty Belt

Kits for your Specific RPM Range

1004-AR-CE 6200 RPM Engine
1004-AR-7200 7200 RPM Engine
1004-AR-7500 7500 RPM Engine
1004-AR-8000 8000+ RPM Engine

1004-AL-CE

Remote-Tank PS Pump

**1004-S-CE**

Pulleys & Bracket Only



PS-8101-B



PS-8101-A

PS-8009-32S
PS-8009-16S

PS-8009-1G

1441-AR-CE**COMPLETE SBC BELT DRIVE SYSTEM:**

Kit Includes Brand New, Aluminum Short Style Water Pump; Alum. Power Steering Pump with Built-In Tank; & a Mini, Lightweight Aluminum, 1-wire 45-idle / 70-max amp Alternator. Kit also features all Billet Aluminum Pulleys & Brackets, which are supplied with all the necessary Belts, Spare Belts, Mounting Hardware and Spacers.

Kits for your Specific RPM Range

1441-AR-CE 6200 RPM Engine
1441-AR-72 7200 RPM Engine
1441-AR-75 7500 RPM Engine
1441-AR-80 8000+ RPM Engine

1005-AL-CE**SBF SERPENTINE WATER PUMP & PS DRIVE SYSTEM**

DH-8101-SR-A	Drive Hub
DH-2109-BC	Hub Bolt Kit
SP-6103-KP	Spacer Kit
CS-5102-F	Crank Pulley
BEC-2109-JC	End Cap & Bolt
WP-5104-C	Water Pump Pulley
WP-5104-MK	Shims & Bushings
PS-8001-F-R	PS Brackets
PS-8001-FR-MK	Hex Stand-Offs
PS-5106-B-4.5"	PS Pulley
5PK-890HD	Heavy Duty Belt

1005-AR-CE

Kit w. Built-in PS Tank

1005-S-CE

Pulleys & Bracket Only

Kits for your Specific RPM Range

1005-S-CE	No Pumps, Just Pulleys
1005-AR-CE	6200 RPM Engine w/ PS Pump
1005-AR-72	7200 RPM Engine w/ PS Pump
1005-AR-75	7500 RPM Engine w/ PS Pump
1005-AR-80	8000 RPM Engine w/ PS Pump

FORD WATER PUMP OPTIONS

EDE-8833



WP-9104-SBF-AL

ALTERNATOR OPTIONS

AL-9101-B-NS
45 idle/70 amps max
Mini 1-Wire Alternator
6 Lbs.



AL-9101-C-NS
65 idle/90 amps max
Mini 1-Wire Alternator
9 Lbs.



AL-9101-E-NS
80 idle/140 amps max
Mini 1-Wire Alternator
11 Lbs.

1565-AR-CE**COMPLETE SB FORD BELT DRIVE SYSTEM:**

Kit Includes Alum. Power Steering Pump with Built-In Tank; & a Mini, Lightweight Aluminum, 1-wire 45-idle / 70-max amp Alternator. Kit also features all Billet Alum. Pulleys & Brackets, which are supplied w. all the necessary Mounting Hardware, Belts, Spare Belts, and Spacers. Shown with optional EDE-8833 Water Pump.

Kits for your Specific RPM Range

1565-AR-CE	6200 RPM Engine
1565-AR-72	7200 RPM Engine
1565-AR-75	7500 RPM Engine
1565-AR-80	8000+ RPM Engine

See our stand alone water pump drive on page 28



1008-S-CE

Small Block Chrysler Serpentine Water Pump & PS Drive System

DH-8101-WC-C	Drive Hub
DH-2109-BC	Hub Bolt Kit
CS-5102-F	Crank Pulley
BEC-2109-HC	End Cap & Bolt
WP-5104-F	Water Pump Pulley
WP-5104-MK	Shims & Bushings
PS-8001-CR-R	PS Bracket
PS-5106-B-4.5"	PS Pulley
5PK-825HD	Heavy Duty Belt

Kits for your Specific RPM Range

1008-AR-CE	6200 RPM Engine
1008-AR-72	7200 RPM Engine
1008-AR-75	7500 RPM Engine
1008-AR-80	8000 RPM Engine

Chrysler Water Pump Options



WP-9104-CRY-AL



EDE-8877

Power Steering Options



PS-9008-AL



PS-9008-AL-R



PS-9008-AL-AR



PS-8101-A



PS-8101-B



PS-8009-32

1875-AR-CE

Complete SB Chrysler Belt Drive System:



Kit Include Alum. Power Steering Pump with Built-In Tank; & a Mini, Lightweight Aluminum, 1-wire 45-idle / 70-max amp Alternator. Kit also features all Billet Aluminum Pulleys & Brackets, which are supplied with all the necessary Belts, Spare Belts, Mounting Hardware and Spacers. Shown with Optional EDE-8877 Water Pump.

Kits for your Specific RPM Range

1875-AR-CE	6200 RPM Engine
1875-AR-72	7200 RPM Engine
1875-AR-75	7500 RPM Engine
1875-AR-80	8000+ RPM Engine

1065-AL-ST

**BIG BLOCK CHEVY SERPENTINE
WP, PS & ALT. DRIVE SYSTEM**

- | | |
|------------------|-------------------------|
| DH-8101-DP-BB | Drive Hub |
| SK-2109-DK | DH Bolt Kit |
| CS-5102-WC-M | Crank Pulley |
| EC-6111-WC-N | Billet Cap |
| WP-9104-1/2"-BB | WP Spacers |
| WP-9104-BBC-AL | Water Pump |
| WP-5104-WC-5-DS | WP Pulley |
| WP-5104-MK | Shims & Bushings |
| PSL-8001-BB-R | PS Bracket |
| PS-9008-AL | PS Pump |
| PS-5106-B-4.500" | PS Pulley |
| 6PK-940 | HD Serpentine Belt |
| AL-9101-E-NS | HD 1-Wire Alternator |
| AL-5105-B-A | Alternator Pulleys |
| AL-9100-CL-C-BB | Alternator Bracket |
| AL-9100-CL-BM-BB | Alternator Support |
| AL-9100-CL-BK-BB | Alternator Mounting Kit |
| 6PK-695 | HD Alternator Belt |

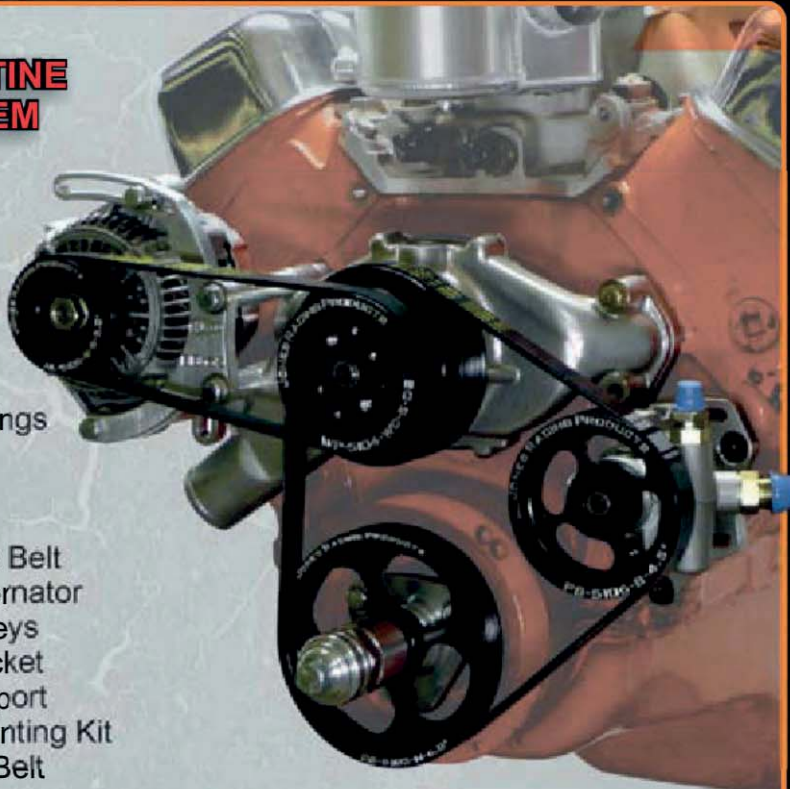

BBC WP, PS & Alternator Drive System



1065-AR-ST-B

"AR" features an integrated PS Tank & the "B" option adds the Blackout Components

BB CHEVY WATER PUMP



EDE-8862



EDE-88503

POWER STEERING OPTIONS



PS-9008-AL



PS-8101-A



PS-8101-B



PS-9008-AL-AR



PS-9008-AL-R

ALTERNATOR OPTIONS



AL-9101-B-NS

45 idle/70 amps max
Mini 1-Wire Alternator
6 Lbs.



AL-9101-C-NS

65 idle/90 amps max
Mini 1-Wire Alternator
9 Lbs.



AL-9101-E-NS

80 idle/140 amps max
Mini 1-Wire Alternator
11 Lbs.



AL-9101-D-NS

100 idle/140 amps max
Mini 1-Wire Alternator
14 Lbs.

2010-RA**SB CHEVY RADIUS TOOTH WATER PUMP DRIVE SYSTEM**

DH-8101-NE-A-2"	Drive Mandrel/Hub
CS-6102-AS-25	Radius Tooth Crank Pulley
BG-6108-A	CS Pulley Belt Guides
SP-6103-A-A-1/4"	Spacer
BEC-2109-D	End Cap & Bolt Kit
WP-6104-35A	Radius Tooth WP Pulley
WP-6104-MK	WP Bushings & Hardware
600-20 HD	HD Radius Tooth WP Belt

Kits for your Specific RPM Range

2010-RA-7	7% Reduction
2010-RA-10	10% Reduction
2010-RA-23	23% Reduction
2010-RA	29% Reduction
2010-RA-F	Ford Setup

WATER PUMP OPTIONS

High Flow, SBC, SWP w/
2 Auxiliary Fittings



EDE-8819 or
EDE-8817



See Page 15
for Oil Pumps

OIL PUMP OPTIONS

Remote Mount
for Oil Filter



OP-8103-F



VP-9106-A

Remote
breather/
oil separator.

Comes w. -12
AN fittings filter
and bracket.

2015-RA**SB CHEVY RADIUS TOOTH WP & OIL PUMP DRIVE SYSTEM**

DH-8101-NE-C-4"	Drive Mandrel/Hub
CS-6102-AS-25	Radius Tooth Crank Pulley
BG-6108-A	CS Pulley Belt Guides
CS-6102-AS-18	Radius Tooth Crank Pulley
SP-6103-KP	Mandrel Spacer Kit
BEC-2109-F	End Cap & Bolt Kit
WP-6104-35A	Radius Tooth WP Pulley
WP-6104-MK	WP Bushings & Hardware
600-20 HD	HD Radius Tooth WP Belt
OP-6103-32-1 1/4"	Oil Pump Pulley
560-20 HD	HD Radius Tooth OP Belt

2004-RA**BELL HOUSING MOUNTED OIL PUMP DRIVE SYSTEM**

OP-6103-38-1 1/4"	Oil Pump Pulley
BG-6108-38S	OP Pulley Belt Guides
RDH-6102-22	Coupler with Built-In Pulley
640-30 HD	HD Radius Tooth Belts

**2004-PS****BELL HOUSING MOUNTED PS DRIVE SYSTEM**

PS-9008-AL	Alum. PS Pump
PS-6106-B-33	PS Pulley
BG-6108-33S	PS Pulley Guides
PS-8001-BH	Bell Housing PS Bracket
RDH-6102-22	Coupler with Built-In Pulley
560-20 HD	HD Radius Tooth Belts

**2004-OP-AL****BELL HOUSING MOUNTED ALT DRIVE SYSTEM, WORK WITH OP**

AL-9101-B-NS	1-Wire Mini Alternator
AL-9100-OP-BH	Bell Housing Alt Bracket
AL-6105-18-A	Alt Pulley
BG-6108-18-CAP	Alt Pulley Guides
RDH-6102-22	Coupler with Built-In Pulley
592-20 HD	HD Radius Tooth Belts

**2004-AL****BELL HOUSING MOUNTED ALTERNATOR DRIVE SYSTEM**

AL-9101-B-NS	1-Wire Mini Alternator
AL-9100-BH	Bell Housing Alt Bracket
AL-6105-18-A	Alt Pulley
BG-6108-18-CAP	Alt Pulley Guides
RDH-6102-22	Coupler with Built-In Pulley
592-20 HD	HD Radius Tooth Belts



Dry Sump (OP-8103-5)
 Sold Separately:
 (See Page 18)

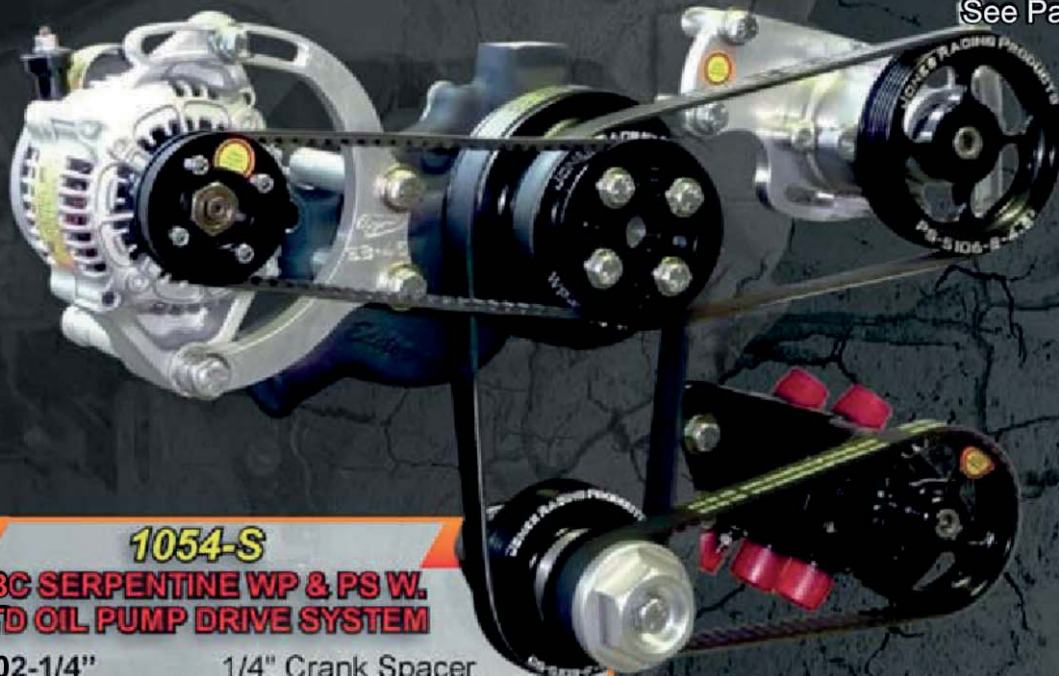

1054-S

SBC SERPENTINE WP & PS W. HTD OIL PUMP DRIVE SYSTEM

- | | |
|--------------------|--------------------------------------|
| DHS-3102-1/4" | 1/4" Crank Spacer |
| DH-5102-R | Register & Balancer Bolt |
| DH-5102-G | Crank Pulley |
| DHS-3102-1/4" | Billet Alum. SB-Offset Spcr Bolt Kit |
| SK-2109-H | Crank Pulley Spacer |
| SP-6103-WC-C-1/2" | Belt Guide |
| BG-6108-WC | HTD OP Drive Pulley |
| CS-6102-WC-22 | End Cap with Large Nut |
| EC-6111-WC-Nx7/16" | |
| WP-5104-WC-5-DS | Water Pump Pulley |
| WP-5104-MK | Shims & Bushings |
| 6PK-695 | HD Serpentine WP Belt |
| PSH-8001-C | PS Bracket |
| PS-9008-AL | PS Pump |
| PS-5106-B-4.500" | PS Pulley |
| 5PK-735 | HD Serpentine PS Belt |
| OP-6103-38-1 1/4" | HTD Oil Pump Pulley |
| 600-20 HD | HTD Oil Pump Belt |
| *Sold Separately: | |
| *2041-RA | SBC HTD Alternator Kit |



1248-AR-78

SBC MODIFIED DRIVE SYSTEM WITH FUEL PUMP WATER PUMP PS W. TANK & ALT



EXPANSION TANKS

EXT-9104-DML
 EXT-9104-DMR

EXT-58037-L
 (Low Profile)

POWER STEERING OPTIONS



PS-9008-AL

PS-8101-A

PS-8101-B

PS-9008-AL-AR

PS-9008-AL-R

PS-8009-32

Dry Sump (OP-8103-5)
Sold Separately:
See Page 18

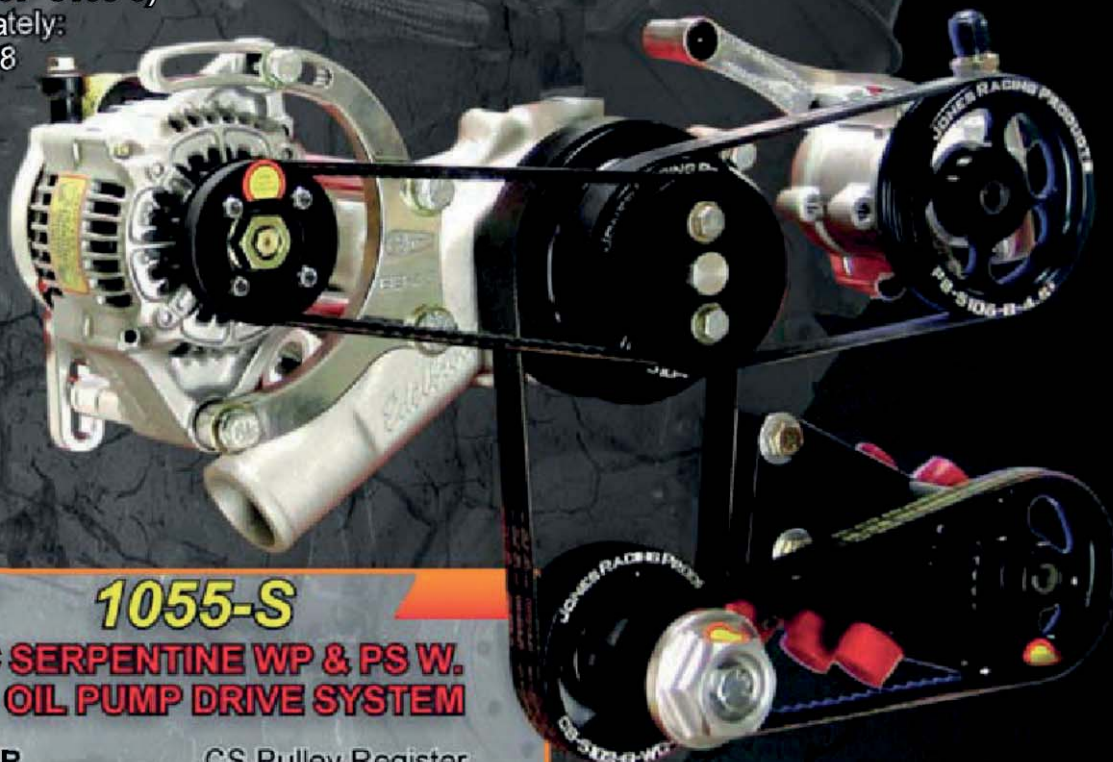

1055-S

BBC SERPENTINE WP & PS W. HTD OIL PUMP DRIVE SYSTEM

DH-5102-R	CS Pulley Register
DH-5102-G	Crank Pulley
SK-2109-H	Bolt Kit
SP-6103-WC-C-1/2"	2 Crank Pulley Spacers
BG-6108-WC	Belt Guide
CS-6102-WC-22	HTD OP Drive Pulley
EC-6111-WC-Nx1/2"	End Cap with Large Nut
WP-5104-WC-5-DS	Water Pump Pulley
WP-5104-MK	Shims & Bushings
6PK-695	HD Serpentine WP Belt
PSH-8001-BB	PS Bracket
PS-9008-AL	PS Pump
PS-5106-B-4.500"	PS Pulley
5PK-690	HD Serpentine PS Belt
OP-6103-38-1 1/4"	HTD Oil Pump Pulley
640-20 HD	HTD Oil Pump Belt
*Sold Separately	
*2031-RA	BBC HTD Alternator Kit

BB CHEVY WATER PUMP



EDE-8852

EXPANSION TANKS



EXT-9104-DML
EXT-9104-DMR

EXT-58037-L
(Low Profile)

ALTERNATOR OPTIONS



AL-9101-B-NS
45 idle/70 amps max
Mini 1-Wire Alternator
6 Lbs.



AL-9101-C-NS
65 idle/90 amps max
Mini 1-Wire Alternator
9 Lbs.



AL-9101-E-NS
80 idle/140 amps max
Mini 1-Wire Alternator
11 Lbs.



AL-9101-D-NS
100 idle/140 amps max
Mini 1-Wire Alternator
14 Lbs.

Dry Sump (OP-8103-5)
Sold Separately:
See Page 18

Small Block Chevy Asphalt Late Model



Lightweight HD Mini 1-Wire Alternator



Fab. Aluminum High Capacity PS Reservoir



Billet Alum. Brackets & Mounting Hardware



Radius Tooth Belt & Billet Alum. Pulleys

4-4698-R

**SBC RADIUS TOOTH DRIVE SYSTEM
WP & PS OIL PUMP & ALTERNATOR**

- | | |
|--------------------------|---------------------------------|
| DH-8101-WC-BB | Drive Hub |
| DH-2109-BC | DH Bolt Kit |
| SP-6103-K | Crank Pulley Spacer |
| CS-6102-AS-25 | Water Pump Crank Pulley |
| BG-6108-A (Qty 2) | Crank Pulley Belt Guides |
| CS-6102-AS-18 | Oil Pump Crank Pulley |
| BG-6108-F (Qty 2) | Crank Pulley Belt Guides |
| CSN-6103-A | Billet Nut to Turnover Engine |
| BEC-2109-HC | Bolt & End Cap Kit |
| WP-6104-35A | Water Pump Pulley |
| WP-6104-MK | Shims & Bushings |
| 600-20 HD | HD Radius Tooth WP Belt |
| PSH-8001-SB-R | PS Bracket |
| PS-9008-AL-AR | PS Pump |
| PS-6106-B-40-15 | Radius Tooth PS Pulley |
| BG-6108-40S | PS Pulley Belt Guides |
| 576-15 HD | HD Radius Tooth PS Belt |
| OP-6103-32-1 1/4" | Radius Tooth Oil Pump Pulley |
| 600-20 HD | HD Radius Tooth OP Belt |
| 2041-RA | SBC Radius Tooth Alternator Kit |

Dry Sump (OP-8103-5, Page 18)
 & Motor Plate (MP-8101-SBC)
 Sold Separately:



4-4698-RMP

SBC RADIUS TOOTH DRIVE SYSTEM WP & PS OIL PUMP & ALTERNATOR

- | | |
|-------------------|-------------------------------|
| DH-8101-WC-BB | Drive Hub |
| DH-2109-BC | DH Bolt Kit |
| SP-6103-K | Crank Pulley Spacer |
| CS-6102-AS-25 | Water Pump Crank Pulley |
| BG-6108-A (Qty 2) | Crank Pulley Belt Guides |
| CS-6102-AS-18 | Oil Pump Crank Pulley |
| BG-6108-F (Qty 2) | Crank Pulley Belt Guides |
| CSN-6103-A | Billet Nut to Turnover Engine |
| BEC-2109-HC | Bolt & End Cap Kit |
| WP-6104-35A | Water Pump Pulley |
| WP-6104-MK | Shims & Bushings |
| 600-20 HD | HD Radius Tooth WP Belt |
| PSH-8001-SB-R | PS Bracket |
| PS-9008-AL-AR | PS Pump |
| PS-6106-B-40-15 | Radius Tooth PS Pulley |
| BG-6108-40S | PS Pulley Belt Guides |
| 576-15 HD | HD Radius Tooth PS Belt |
| OP-6103-32-1 1/4" | Radius Tooth Oil Pump Pulley |
| 600-20 HD | HD Radius Tooth OP Belt |
| 2041-RA | SBC Radius Tooth Alt Kit |



Remote-Tank Aluminum
 PS Pump also Available



Synthetic PS Fluid
 PS-8009-16 & 32



-6 AN &
 -10 AN
 fittings



-6 AN &
 -10 AN
 fittings

PS Reservoir
 PS-8101-A

PS Reservoir
 PS-8101-B



Expansion Tank
 EXT-9104-TM



Expansion Tank
 EXT-9104-SK

Small Block Chevy NASCAR Modified



2001-RA
SBC RADIUS TOOTH TANDEM FUEL PUMP DRIVE SYSTEM

WP-9104-28-.825	FP Drive Pulley
WP-6104-B	Fan Register
BG-9108-W	FP Drive Pulley Belt Guide
OP-6103-37-1 1/4"	Fuel Pump Pulley
BG-6108-37S	FP Pulley Belt Guide
FP-9100-C	SBC, SWP FP Bracket
720-20 HD	Radius Tooth Belt

SB/BBC	Ford	Chrysler	Bell Housing
			
FP-9100-E Kit# 2001-BB	FP-9100-A Kit# 2001-F	FP-9100-F Kit# 2001-CR	FP-9100-BH kit # 2001-BH

FUEL PUMP OPTIONS

	
KSE-8009-CX KSE Tandem-X Pump Combination PS & FP	FP-8009-A Belt Driven FP

2001-CS



FUEL FILTERS

FP-7100-6	-6 in-line Fuel Filter, 100 Micron Filter
FP-7100-8	-8 in-line Fuel Filter, 100 Micron Filter
FP-7100-10	-10 in-line Fuel Filter, 100 Micron Filter
FP-7100-12	-12 in-line Fuel Filter, 100 Micron Filter
FP-8009-R	Billet Return Bypass Fuel Regulator
FP-8009-S	Fuel Shut-Off to Pump w/ Swiveling Union



Cam Belt Drive Kit, Runs in Oil and Fits Under the Stock Cover 1 1/8" Wide Heavy Duty Belt

41

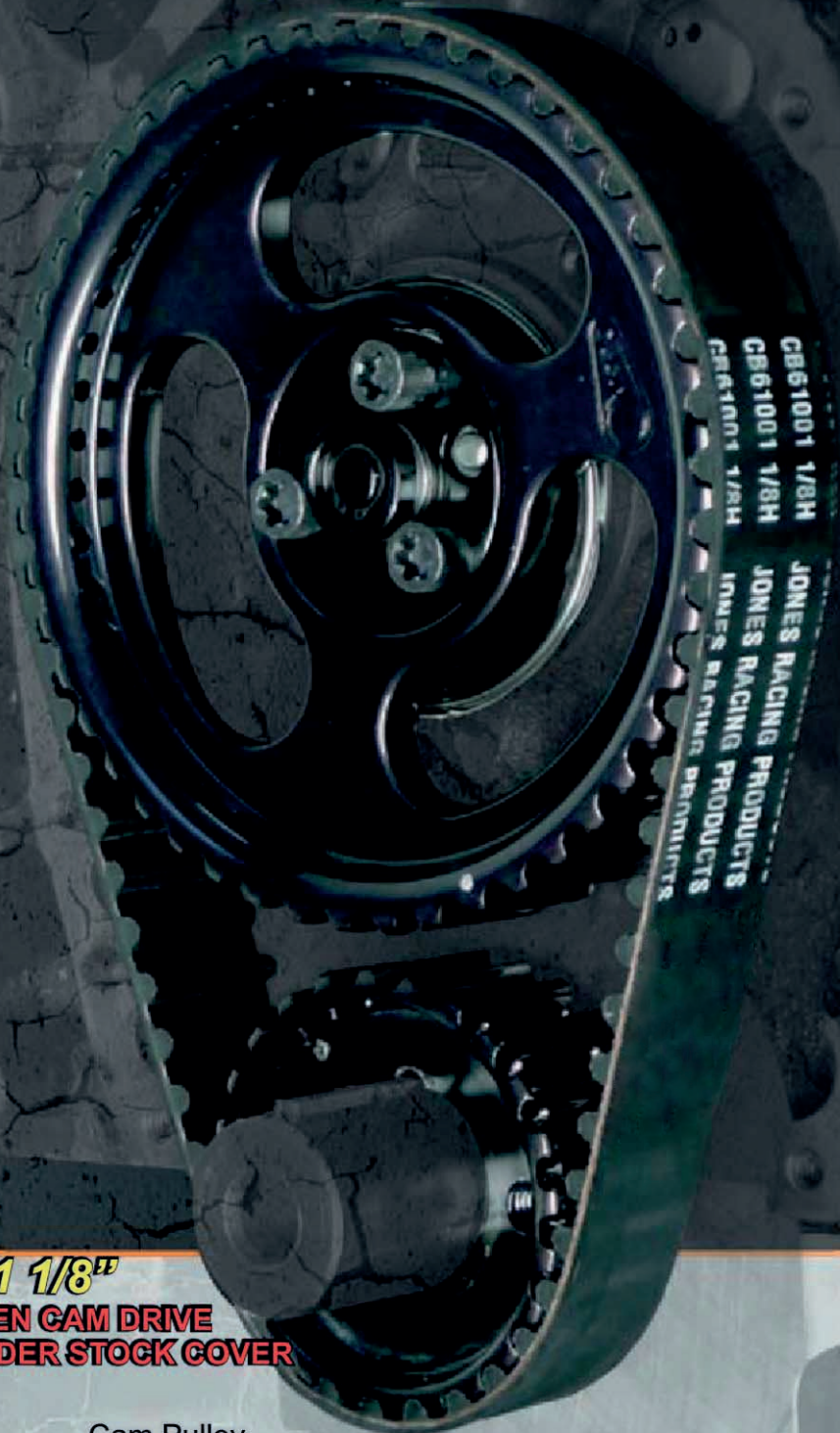

CDA-8001-1 1/8^{HD}

**SBC BELT DRIVEN CAM DRIVE
RUNS IN OIL UNDER STOCK COVER**

- | | |
|-------------------|---------------------------|
| CP-8001-A | Cam Pulley |
| CS-8001-A | Crank Pulley (SB Snout) |
| CB-8001-A | Cam Button |
| CB-8001-B | Bearings for Cam Pulley |
| CB-8001-C | Bolts for Cam Pulley |
| CS-8001-1 1/8"-HD | Heavy-Duty Cam Drive Belt |

OPTIONS

- | | |
|----------------|----------------------|
| CS-8001-B | CS Pulley (BB Snout) |
| CS-8001-1 1/8" | Normal Duty Belt |

Belt Cam Drive, Runs in Oil Under Stock Cover

41

2040 SBC V-BELT ALTERNATOR KIT

AL-9101-B-NS	45 amp, 1-Wire Alternator
AL-3105-A-B-2.500"	2.5" V-Belt Alt. Pulley
WP-3104-A-3.500"	3.5" Alt. Drive Pulley
2700-375	27" V-Belt
AL-9100-CL-B	Alternator Bracket
AL-9100-CL-HM	Rear Alt. Support
AL-9100-CL-BK	Mounting Kit
SW-9100-A	Switch

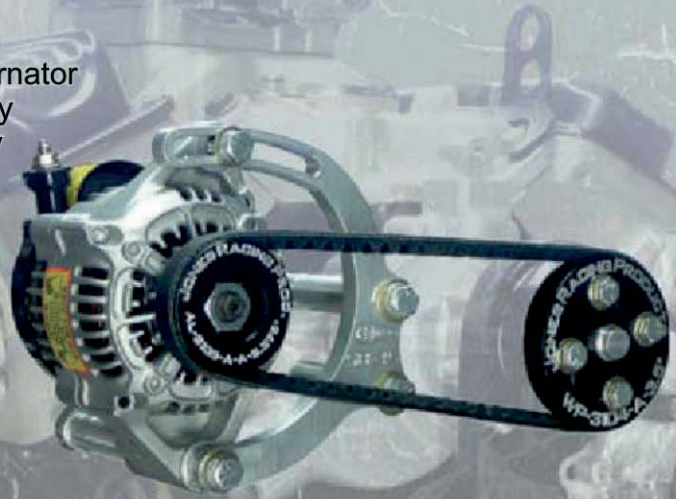

Block Mount Rear Support arm for 2040 & 2041-RA
AL-9100-CL-BM (shown)



Head Mount Rear Support arm for 2040 & 2041-RA
AL-9100-CL-HM



See Pages 43 & 44 for more SBC Alternator Options

2041-RA SBC RADIUS TOOTH ALTERNATOR KIT

AL-9101-B-NS	45 amp, 1-Wire Alternator
AL-9105-24-A	24 Tooth Alt. Pulley
WP-9104-32	32 Tooth Drive Pulley
BG-9108-W	Belt Guide
672-10 HD	Radius Tooth Belt
AL-9100-CL-B	Alternator Bracket
AL-9100-CL-HM	Rear Alt. Support
AL-9100-CL-BK	Mounting Kit
SW-9100-A	Switch

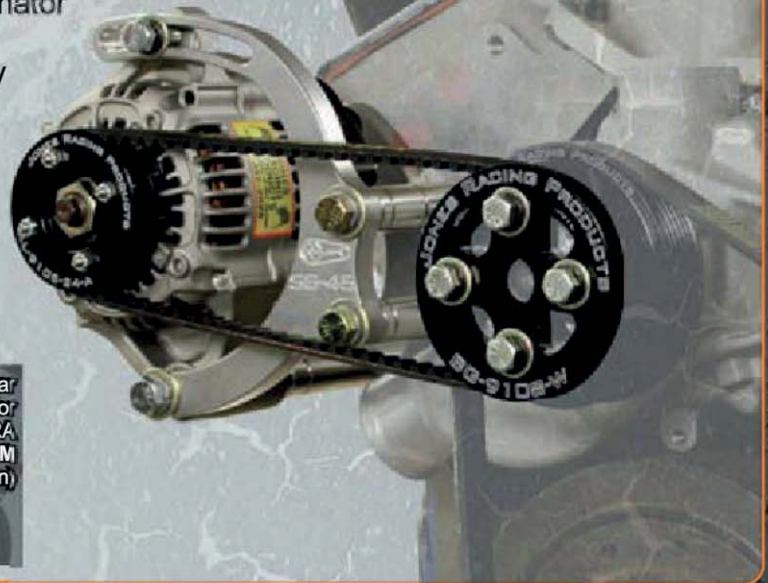

Block Mount Rear Support arm for 2040 & 2041-RA
AL-9100-CL-BM



Head Mount Rear Support arm for 2040 & 2041-RA
AL-9100-CL-HM (shown)

**ALTERNATOR OPTIONS**

AL-9101-B-NS
45 idle/70 amps max
Mini 1-Wire Alternator
6 Lbs.



AL-9101-C-NS
65 idle/90 amps max
Mini 1-Wire Alternator
9 Lbs.



AL-9101-E-NS
80 idle/140 amps max
Mini 1-Wire Alternator
11 Lbs.



AL-9101-D-NS
100 idle/140 amps max
Mini 1-Wire Alternator
14 Lbs.

2050-RA SBC UNIVERSAL, BLOCK-MOUNT, ALTERNATOR KIT

- AL-9105-24-A 24 Tooth Alt. Pulley
- WP-9104-32 32 Tooth Drive Pulley
- BG-9108-W Belt Guide
- 656-10 HD Radius Tooth Belt
- AL-9100-CL-SB Alternator Bracket
- ADR-9100-3.5" Adjusting Rod
- SW-9100-A Switch



See Pages 42 & 44 for more SBC Alternator Options

2051-RA SBC RADIUS TOOTH, BLOCK-MOUNT ALTERNATOR KIT

- AL-9101-B-NS 45 amp, 1-Wire Alternator
- AL-9105-24-A 24 Tooth Alt. Pulley
- WP-9104-32 32 Tooth Drive Pulley
- BG-9108-W Belt Guide
- 656-10 HD Radius Tooth Belt
- AL-9100-CL-SB Alternator Bracket
- ADR-9100-3.5" Adjusting Rod
- SW-9100-A Switch

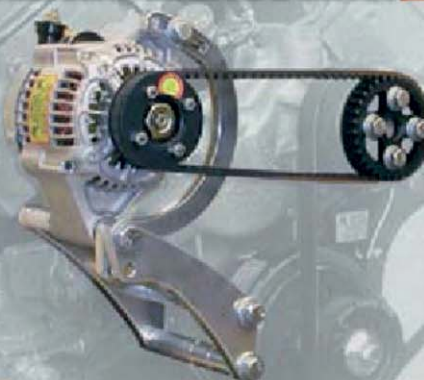

2067-RA SBC LOW MOUNT RADIUS TOOTH ALTERNATOR KIT

- DH-8101-C Drive Hub
- SK-2109-D-3/8x1.25" Bolt Kit
- DHM-8101-A Drive Mandrel
- BEC-2109-B End Cap & Bolt
- AL-9101-C-NS 65 amp, 1-Wire Alt.
- AL-9105-24-A 24 Tooth Alt. Pulley
- CS-6102-AC-35 35 Tooth Crank Pulley
- BG-6108-C Belt Guides
- 680-10 HD Radius Tooth Belt
- AL-9101-SB-LM Alternator Bracket
- ADR-9100-2.5" Adjusting Rod
- SW-9100-A Switch



requires a minimum of 10.75" from the center of the crank to the frame rail.

ALTERNATOR OPTIONS



AL-9101-B-NS
45 idle/70 amps max
Mini 1-Wire Alternator
6 Lbs.



AL-9101-C-NS
65 idle/90 amps max
Mini 1-Wire Alternator
9 Lbs.



AL-9101-E-NS
80 idle/140 amps max
Mini 1-Wire Alternator
11 Lbs.



AL-9101-D-NS
100 idle/140 amps max
Mini 1-Wire Alternator
14 Lbs.

SB Chevy Alternator Kits

2052-RA SBC RADIUS TOOTH ALTERNATOR KIT

See Pages 39 & 40 for more SBC Alternator Options

- AL-9101-B-NS 45 amp, 1-Wire Alternator
- AL-9105-24-A 24 Tooth Alt. Pulley
- WP-9104-32 32 Tooth Drive Pulley
- BG-9108-W Belt Guide
- 560-10 HD Radius Tooth Belt
- WPM-9101-C Alternator Bracket
- ADR-9100-6.5" Adjusting Rod
- SW-9100-A Switch



2053-RA SBC RADIUS TOOTH ALTERNATOR KIT

- AL-9101-B-NS 45 amp, 1-Wire Alternator
- AL-9105-24-A 24 Tooth Alt. Pulley
- WP-9104-32 32 Tooth Drive Pulley
- BG-9108-W Belt Guide
- 480-10 HD Radius Tooth Belt
- WPM-9101-A Alternator Bracket
- ADR-9100-6" Adjusting Rod
- SW-9100-A Switch



2056-RA SBC, LONG WATER PUMP RADIUS TOOTH ALTERNATOR KIT

- AL-9101-B-NS 45 amp, 1-Wire Alternator
- AL-9105-24-A 24 Tooth Alt. Pulley
- WP-9104-32 32 Tooth Drive Pulley
- BG-9108-W Belt Guide
- 640-10 HD Radius Tooth Belt
- AL-9101-SB Alternator Bracket
- ADR-9100-3.5" Adjusting Rod
- SW-9100-A Switch



ALTERNATOR OPTIONS



AL-9101-B-NS
45 idle/70 amps max
Mini 1-Wire Alternator
6 Lbs.



AL-9101-C-NS
65 idle/90 amps max
Mini 1-Wire Alternator
9 Lbs.



AL-9101-E-NS
80 idle/140 amps max
Mini 1-Wire Alternator
11 Lbs.



AL-9101-D-NS
100 idle/140 amps max
Mini 1-Wire Alternator
14 Lbs.

2057-RA SB FORD RADIUS TOOTH ALTERNATOR KIT

AL-9101-B-NS	45 amp, 1-Wire Alternator
AL-9105-24-A	24 Tooth Alt. Pulley
WP-9104-32	32 Tooth Drive Pulley
BG-9108-W	Belt Guide
640-10 HD	Radius Tooth Belt
AL-9101-F3	Alternator Bracket
ADR-9100-5"	Adjusting Rod
SW-9100-A	Switch

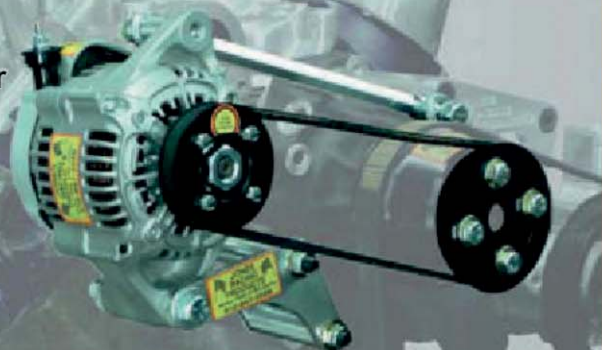
**2065-RA SB FORD RADIUS TOOTH ALTERNATOR KIT**

AL-9101-B-NS	45 amp, 1-Wire Alternator
AL-9105-24-A	24 Tooth Alt. Pulley
WP-9104-32	32 Tooth Drive Pulley
BG-9108-W	Belt Guide
656-10 HD	Radius Tooth Belt
AL-9100-CL-F-B	Alternator Bracket
AL-9100-CL-BK-F	Alt. Mounting Kit
AL-9100-CL-HM-F	Alt. Rear Support
SW-9100-A	Switch

**2070-RA SB****FORD HEAD MOUNT RADIUS TOOTH ALTERNATOR KIT**

DH-8101-WC-F3-3.5"	Drive Hub
SP-6103-K	Spacer Kit
BEC-2109-HC	End Cap & Bolt
CS-6102-AS-35	35 Tooth Crank Pulley
BG-6108-35	Crank Pulley Belt Guides
656-20	HD Radius Tooth Belt
AL-6105-22-B	22 Tooth Alt. Pulley
BG-6108-22-CAP	Alt. Pulley Belt Guide
AL-9101-D-NS	120+ amp, 1-Wire Alt.
AL-9101-ADP	Pivot Arm Adjust
AL-9100-RH-B	Back Alt. Bracket
AL-9100-RH-F	Front Alt. Bracket
AL-9100-MK	Mounting Kit
ADR-9100-2.5"	Adjusting Rod



2058-RA SB Chrysler Radius Tooth Alternator Kit

- AL-9101-B-NS** 45 amp, 1-Wire Alternator
- AL-9105-24-A** 24 Tooth Alt. Pulley
- WP-9104-32** 32 Tooth Drive Pulley
- BG-9108-W** Belt Guide
- 536-10 HD** Radius Tooth Belt
- CH-9101-A** Alternator Bracket
- ADR-9100-3.5"** Adjusting Rod
- SW-9100-A** Switch



2075-RA SB Chrysler Radius Tooth Alternator Kit

- AL-9101-B-NS** 45 amp, 1-Wire Alternator
- AL-9105-24-A** 24 Tooth Alt. Pulley
- WP-9104-32** 32 Tooth Drive Pulley
- BG-9108-W** Belt Guide
- 680-10 HD** Radius Tooth Belt
- AL-9100-CL-CR-B** Alternator Bracket
- AL-9100-CL-BK-R** Mounting Kit
- AL-9100-CL-BM-CR** Rear Support Arm
- SW-9100-A** Switch

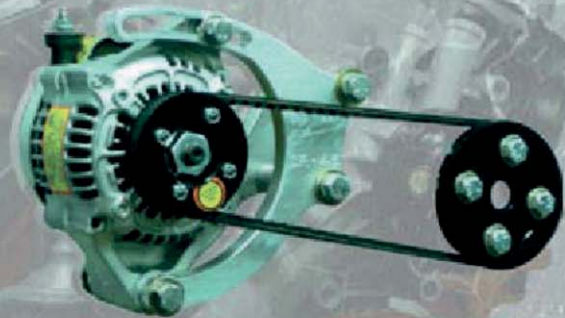

ALTERNATOR OPTIONS



AL-9101-B-NS
45 idle/70 amps max
Mini 1-Wire Alternator
6 Lbs.



AL-9101-C-NS
65 idle/90 amps max
Mini 1-Wire Alternator
9 Lbs.



AL-9101-E-NS
80 idle/140 amps max
Mini 1-Wire Alternator
11 Lbs.



AL-9101-D-NS
100 idle/140 amps max
Mini 1-Wire Alternator
14 Lbs.

JONES

Racing Products

Billet Aluminum Motor Plate Drive Systems

Available in Radius Tooth HTD, Serpentine, and V-Blet



Stand-Alone Water Pump Drives

Available in Serpentine, V-Belt and Radius Tooth; many ratios available



Serpentine

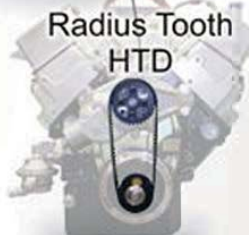

Radius Tooth
HTD



Dual V-Belt
Individually Adjustable

Drive Systems For:

SB & BB Chevys
SB & BB Fords
and Chrysler

Pulleys & Brackets for:

Alternators
Fuel Pumps, Oil Pumps
Vacuum Pumps,
Power Steering Pumps &
Water Pumps

Engine Components:

1-Wire Alternators
Fuel & Tandem Pumps
Billet Vacuum Pumps
Power Steering Pumps
Oil Pumps, & Water Pumps
and the industries largest
selection of belts; including

Radius Tooth HTD, Gilmer & Serpentine

Radius Tooth Drive System
Any Combination including Alternators, Power Steering, Water, Oil, Fuel & Vacuum Pumps available in many configurations.

35, 45, 65, 80, and
120 amp 1-wire Alt.
Systems































2-Stage Vacuum Pump
with a 1-Year Warranty



High Performance Street
applications



-  01 - Alternator Pulleys
-  02 - Alternator Drive Pulleys, 5/8" WP Shaft Bushing and Fan Adapter/Register
-  03 - One-Wire Switchless (Self Exciting) Alternators & Wiring Diagram
-  04 - Alternator Brackets
-  05 - Drive Hubs, Mandrels, Drive Hub Spacers, and End Caps
-  06 - Drive Hubs, SB to BB, and BB to SB Chevy Drive Hub Adapters
-  07 - Drive Hub Spacer, Bolts, Keys, Roll Pins, and Related Accessories
-  08 - V-Belt Crankshaft Pulleys & Split-V Drive Hubs, Spacers & Shims
-  09 - Square Tooth Gilmer Crankshaft Pulleys and Belt Guides
-  10 - Serpentine Poly-V Crankshaft Pulleys & Spacers for 1 1/8" & WC (Dual Dowel) assemblies
-  11 - Radius Tooth HTD Crankshaft Pulleys for 1 1/8", 1" & WC (Dual Dowel) assemblies
-  12 - Fuel Pump Pulleys, Fuel Pumps and Belt Guides
-  13 - Fuel Pump Brackets
-  14 - Radius Tooth & Square Tooth Oil Pump Pulleys, Guides, Locking Collets, & Primer
-  15 - Oil Pumps, AN Hosing, Fittings, Plugs and Support Coil.
-  16 - Oil Pump Brackets for SBC and Ford
-  17 - Radius & Square Tooth, Serpentine & V-Belt Power Steering Pulleys & Pump Reservoirs, Remote Reservoirs, PS Fluid, and PS Pump Press on Hub
-  18 - Aluminum & Steel PS Pumps with or without Built-In Reservoirs & Orientation Bracket
-  19 - Power Steering Brackets for SBC, BBC, Ford, Chrysler, and Engine Plates
-  20 - SB & BB Chevy Radius Tooth HTD, Two Stage, Vacuum Pump & Drive System Kit
-  21 - Vacuum Pumps, Vacuum Pump Pulleys, Vacuum Pump Brackets, & Related Accessories
-  22 - Single, Double and Triple V-Belt Water Pump Pulleys & Related Accessories
-  23 - Radius Tooth HTD, Serpentine Poly-V and Square Tooth Gilmer Water Pump Pulleys
-  24 - Belt Guides
-  25 - Accessories: Water Restrictor, Expansion Tank, Engine Seal/Cover Sets for Storage
-  26 - Accessories: Inspection Light, Laser Guided Temp Guns, Spark Plug Indexers, wrenches to Turn Over Engine.
-  27 - Power Steering Pulley installation and Removal Kits
-  28 - 1/2" Thick Billet Aluminum AN Wrenches

-  29 - Belt Driven Cam Drive, Fits under Stock Cover and Runs in Oil
-  30 - 1004-S-SB-NE: SBC Serpentine Crankshaft to Water Pump & Power Steering, 1 Belt
-  31 - 1005-S: Ford Serpentine Crankshaft to Water Pump & Power Steering, 1 Belt
-  32 - 1008-S: Chrysler Serpentine Crankshaft to Water Pump & Power Steering, 2 Belts
-  33 - 1014-SMP: SBC Engine Plate Kit, Serpentine Crankshaft to Water Pump & Power Steering, 1 Belt, Radius Tooth HTD Water Pump to Alternator
-  34 - 1015-FMP: Ford Engine Plate Kit, Serpentine Crankshaft to Water Pump & Power Steering, 1 Belt, Radius Tooth HTD Water Pump to Alternator
-  35 - 1018-RMP: Chrysler Engine Plate Kit, Serpentine Crankshaft to Water Pump & Power Steering, 1 Belt, Radius Tooth HTD Water Pump to Alternator
-  36 - 1025-S: SB Chevy Serpentine Crankshaft to Water Pump Drive, 1026-S: SB Ford Serpentine Crankshaft to Water Pump Drive
-  37 - 1049-S: SB Chevy Serpentine Crankshaft to Water Pump Drive & Alternator, Serpentine crankshaft to power steering, 2 belt
-  38 - 2001-RA: SB Chevy Radius Tooth HTD Water Pump to Fuel (tandem) Pump Drive
-  39 - 2002-RA: SB Chevy Radius Tooth HTD Crankshaft to Oil Pump Drive
-  40 - 2004-RA: Rear Bell Housing Radius Tooth HTD Crankshaft to Oil Pump Drive
-  41 - 2010-RA: SB Chevy Radius Tooth HTD Crankshaft to Water Pump
2015-RA: SB Chevy Radius Tooth HTD CS to Water Pump & CS to Oil Pump Drive
-  42 - 2030: BB Chevy V-Belt Water Pump to Alternator Drive
-  43 - 2031-RA: BB Chevy Radius Tooth HTD Water Pump to Alternator Drive
-  44 - 2040: SB Chevy V-Belt Water Pump to Alternator Drive
-  45 - 2041-RA: SB Chevy Radius Tooth HTD Water Pump to Alternator Drive
-  46 - 2043-RA: BB or SB Chevy Radius Tooth HTD Crankshaft to Alternator Drive
2044-RA: BB or SB Chevy Radius Tooth HTD Water Pump to Alternator Drive
-  47 - 2050-RA: SB Chevy Radius Tooth HTD Water Pump to Alternator Drive (Any Alt. Brkt)
2051-RA: SB Chevy Radius Tooth HTD Water Pump to Alternator Drive (JRP Alt. Brkt)
-  48 - 2052-RA: SB Chevy Radius Tooth HTD Water Pump to Alternator Drive (Regular Design)
2053-RA: SB Chevy Radius Tooth HTD Water Pump to Alternator Drive (Compact Design)
-  49 - 2054-RA: BB Chevy Radius Tooth HTD Water Pump to Alternator Drive
2055-RA: Engine Plate Radius Tooth HTD Water Pump to Alternator Drive
-  50 - 2056-RA: BB Chevy Radius Tooth HTD Water Pump to Alternator Drive (Long Water Pump)
2057-RA: SB Ford Radius Tooth HTD Water Pump to Alternator Drive
-  51 - 2058-RA: Chrysler Radius Tooth HTD Water Pump to Alternator Drive
-  52 - 2059-F: Ford 9" Rear, V-Belt, Alternator Drive
2059: Quick Change Rear, V-Belt, Alternator Drive
-  53 - 2065-RA: SB Ford Radius Tooth HTD Water Pump to Alternator Drive (Mounts from WP)
2066-RA: SB Ford Radius Tooth HTD Crankshaft to Alternator Drive (Mounts from Head)
-  54 - 2067-RA: SB Chevy Radius Tooth HTD Low Mount Alternator Kit
2068-RA: BB Chevy Radius Tooth HTD Low Mount Alternator Kit
-  55 - 3001-SB: SB Chevy Dual V-Belt Crankshaft to Water Pump Drive
1025-S: SB Chevy Serpentine Crankshaft to Water Pump Drive
-  56 - Water Pumps, Spacers, Pulley Shims, Radiator Restrictor, Fan Adapter & Shaft Bushing
-  57 - Belts

Lightweight Billet Aluminum Alternator Pulleys

Available for GM & JRP Alts., Made from Billet Aluminum, Hard Coated to Ensure a Long Life

Radius Tooth HTD Alternator Pulleys (1/2" Wide, 10mm Belt)

Billet aluminum lightweight design. All of our 9105 series pulleys are supplied with belt guides.

An 'A' at the end of the part number indicates the pulley has a .590" bore. A 'B' after the part number indicates a .669" bore to fit GM alternators. These pulleys are 1/2" wide and use a 10mm wide belt shown on page 47.



AL-9105-24-A (.590 Bore) **AL-9105-24-B** (.669 Bore)
AL-9105-32-A (.590 Bore) **AL-9105-32-B** (.669 Bore)

Gilmer Square Tooth Alternator Pulleys (1/2" Wide, 1/2" Belt)

Billet aluminum lightweight design. All of our alternator pulleys are supplied with belt guides.

An 'A' at the end of the part number indicates the pulley has a .590" bore. A 'B' after the part number indicates a .669" bore to fit GM alternators. These pulleys are 1/2" wide & use the 1/2" square tooth belts on pg 47.



AL-9105-20-SQ (.590 Bore, Uses 1/2" wide belt 'L-050')
AL-9105-27-SQ (.590 Bore, Uses 1/2" wide belt 'L-050')

Radius Tooth HTD Alternator Pulleys (1" Wide, 20mm Belt)

Billet aluminum lightweight design. An optional belt guide is available for both our 18 & 22 tooth pulleys. part number BG-9108-18 or 22.

A 'B' after the part number indicates a .669" bore to fit GM alternators. These pulleys are .825" wide and use the 20mm wide belts on page 47.



AL-6105-18-A (.590 Bore) **AL-6105-22-A** (.590 Bore)
AL-6105-18-B (.669 Bore) **AL-6105-22-B** (.669 Bore)

Belt Guides For Alternator Pulleys

Lightweight 9108 series aluminum belt guides are supplied with our alternator pulleys. All of our belt guides feature our Removable & reusable design, alternator guides mount with four 6/32 bolts.



BG-9108-A (24-Tooth Radius Tooth)
BG-9108-B (20-Tooth Gilmer Pulley)
BG-9108-C (32-Tooth Radius Tooth)
BG-9108-D (27-Tooth Gilmer Pulley)

Billet Belt Guide for .825 wide AL Pulleys

Billet aluminum belt guide for AL-6105-18 and AL-6105-22, .825" wide, alternator pulleys. Press fit design with a smooth aluminum surface perfect for a polished finish.



BG-9108-18 **BG-9108-22**

Billet Aluminum External Alternator Fan

Billet aluminum lightweight design. This fan is designed to work with GM alternators, and most alternators requiring an external fan. Available in a .669" bore. Please note that all of our alternators have an internal fan.



F-9105-GM Fan Blade (.669 Bore)

Serpentine Poly-V Alternator Pulleys (5 Groove Belt)

Billet aluminum lightweight design. Our alternator pulleys are made to work with our 5 groove belts (5PK).

All of our serpentine pulleys are designed with an extra groove to make it easier to properly align the belt with the pulleys. (Page 47)



AL-5105-A-A-2.5" (.590 Bore) **AL-5105-B-A-2.5"** (.669 Bore)
AL-5105-A-C-4.0" (.590 Bore) **AL-5105-B-B-3.0"** (.669 Bore)
AL-5105-B-C-4.0" (.669 Bore)

V-Belt Alternator Pulleys (1/2" Wide Belt)

AL-3105-A-A-2.375" (.590 Bore)
AL-3105-A-B-2.500" (.590 Bore)
AL-3105-A-C-3.000" (.590 Bore)
AL-3105-A-D-4.500" (.590 Bore)
AL-3105-A-E-5.000" (.590 Bore)
AL-3105-A-F-5.500" (.590 Bore)
AL-3105-A-G-6.000" (.590 Bore)
AL-3105-A-H-7.000" (.590 Bore)



See page 57 for Radius Tooth HTD, Gilmer and serpentine belts. Alternator kits start on page 41

Lightweight Billet Aluminum Alternator Drive Pulleys

Compatible with .625 & .750 Water Pump Shafts, Made from Billet Aluminum, Hard Coated to Ensure a Long Life

Radius Tooth HTD Alternator Drive Pulleys (1/2" Wide)

Billet aluminum lightweight design. For Use with 10mm wide Radius Tooth HTD Belt

Supplied with WP-6104-C bushing to relocate & register mechanical fans

Fits all major bolt hole circles on the water pump hub, .625 and .75 shafts

WP-9104-32 (32-tooth mounts to water pump)



Belt Guides For Alternator Pulleys

Lightweight aluminum belt guide, mounts in front of alternator drive pulley.

BG-9106-W



Radius Tooth HTD Alternator Drive Pulleys (.825" Wide)

Billet aluminum lightweight design. For Use with 20mm wide Radius Tooth HTD Belt

Supplied with WP-6104-C bushing to relocate & register mechanical fans

Fits all major bolt hole circles on the water pump hub, .625 and .75 shafts

WP-9104-28-.825 (28-tooth mounts to water pump)



Adapter to Register Fan

Billet aluminum shaft extension for use with JRP drive pulleys which mount in front of the water pump pulley. This bushing allows you to properly register & relocate the fan with the water pump shaft.

WP-6104-C



Serpentine Poly-V Alternator Drive Pulley (5 Groove Belt)

Billet aluminum lightweight design. Our alternator pulleys are made to work with our 5 groove belts (5PK).

Supplied with WP-6104-C bushing to relocate & register mechanical fans

Fits all major bolt hole circles on the water pump hub, .625 and .75 shafts

AL-5104-3.25" (3.25" OD, 5 Groove Serpentine)



Water Pump Pulley Bushing

Billet aluminum bushing with .750" outside diameter and a .625" inside diameter to allow all of our water pump pulleys to work on either a .625 shaft or .750 shaft. included with all water pump pulley purchases.

WP-6104-B



V-Belt Alternator Drive Pulley (1/2" Belt)

Billet aluminum lightweight design. All of our V-Belt pulleys work with a .5" wide v-belt.

Supplied with WP-6104-C bushing to relocate & register mechanical fans

Fits all major bolt hole circles on the water pump hub, .625 and .75 shafts

WP-3104-A-3.500" (3.5" OD, .375 to .500 V-belt)



Lightweight 1-Wire Switched/Switchless Alternators

Available in 35, 45, 65, 80 and 120 Amp Models, All One-Wire, and available in a Switched or Switchless Model

120 amp One Wire Alternators

120 amp. rating at 3000 RPM
weighs 12.8 pounds

One-wire setup, requires only one 10 guage wire to be run from the back terminal of the alternator to the battery.

AL - 9101 - D - NS



80 amp One wire Alternators

80 amp. rating at 3000 RPM
Weighs only 11 pounds

One-wire setup, requires only one 10 guage wire to be run from the back terminal of the alternator to the battery.

AL - 9101 - E - NS No switch required



65 amp One wire Alternators

65 amp. rating at 3000 RPM
Weighs only 9 pounds
One-wire setup, requires only one 10 guage wire to be run from the back terminal of the alternator to the battery.

AL - 9101 - C - NS No switch required
AL - 9101 - C Requires SW-9100-A switch



45 amp One wire Alternators

45 amp. rating at 3000 RPM
Weighs only 6 pounds
One-wire setup, requires only one 10 guage wire to be run from the back terminal of the alternator to the battery.

AL - 9101 - B - NS No switch required
AL - 9101 - B Requires SW-9100-A switch



35 amp One wire Alternators

35 amp. rating at 3000 RPM
Weighs only 5.6 pounds
One-wire setup, requires only one 10 guage wire to be run from the back terminal of the alternator to the battery.

AL - 9101 - A - NS No switch required
AL - 9101 - A Requires SW-9100-A switch



High Amperage Switch

Heavy-duty, high amperage switch for switched models.

SW - 9100 - A



...Switchless Design:...

When charging your battery be sure to unhook the charger or switchless alternator before starting the engine

Lightweight Billet Aluminum Alternator Brackets

Brackets for BB & SB Chevy, Ford, and Chrysler, Made for JRP 35, 45, 65, 80 & 120 amp Alternators, Brackets are also available for factory alternators. View Complete Alternator Kits starting on Page 37

Alternator Bracket used with kits 2043/2044

Billet aluminum lightweight, rigid design. 2 piece setup, supplied with mounting kit. Mounts from the bottom left or right of your SB or BB Chevy. Uses adjusting rod: ADR-9100-3.5".

EBM - 9100 - A
MP - 9101 - C



Alternator Bracket used with kit # 2056

Billet aluminum lightweight, rigid 2-piece setup, supplied with mounting kit. mounts to your long, small block chevy water pump & uses adjusting rod ADR-9100-3.5"

AL-9101-SB



Alternator Bracket, kits 2050/2051

Billet aluminum lightweight, rigid design. 3 piece setup, supplied with mounting kit. Mounts from Bottom left or right of your Small Block Chevy.

AL-9100-CLA-35

35, 45, 65, 80, 120 amp, or GM alternator, please specify at the end of the part number

AL-9100-CL-SB



Alternator Bracket used with kit # 2057

Billet aluminum lightweight, rigid design. Two piece setup, supplied with mounting kit. Mounts to the water pump on your Small Block Ford. Works with adjusting rod ADR-9100-5".

AL-9101-F3



Alternator Bracket used with kits 2052/2054

Billet aluminum lightweight, rigid design. Single bracket setup with adjusting rod. Supplied with mounting kit. Mounts to left or right side of your SB or BB chevy water pump. SB uses ADR-9100-6" BB uses ADR-9100-8" adjusting rod.

WPM-9101-C



Alternator Bracket used with kit # 2058

Billet aluminum lightweight, rigid design. Two piece setup, supplied with mounting kit. Mounts to the water pump on your Small Block Chrysler. Uses adjusting rod ADR-9100-3.5".

CH-9101-A



Alternator Bracket used with kit # 2053

Billet aluminum lightweight, rigid design. 1 piece setup, supplied with mounting kit. Designed to mount alternator closely to your small block chevy water pump, uses adjusting rod ADR-9100-6".

WPM-9101-A



Ford Alternator Bracket

Billet aluminum lightweight, rigid design. 2 piece setup, supplied with mounting kit. mounts to the head of your Ford, works on either the left or right side of engine. Uses adjusting rod ADR-9100-5".

HM - 9101 - F - SB
MP - 9101 - C



Alternator Bracket used with kit # 2055

Billet aluminum lightweight, rigid design. one piece setup, supplied with mounting kit. Mounts to any motor plate, or to EMP-9100-A (SBC/BBC). Call for the adjusting rod that will best fit your unique application.

MP-9101-C



Alternator Bracket used with kit # 2059

Billet aluminum lightweight, rigid design. 1 piece setup. Mounts alternator on Quick Change or Ford 9" rear ends.

QCM-9101-A (Quick Change Rear)
F9-9101-A (Ford 9 Inch Rear)



Alternator Brackets Available for SB and BB Chevy

- AL-9100-CL-B
- AL-9100-CL-C
- AL-9100-CL-BM
- AL-9100-CL-BK
- AL-9100-CL-B-BB
- AL-9100-CL-C-BB
- AL-9100-CL-BM-BB
- AL-9100-CL-BK-BB

- SBC 45 amp alt.
- SBC 65 or 80 amp alt.
- SBC Rear Support
- SBC Bolt Kit
- BBC 45 amp alt.
- BBC 45 or 80 amp alt.
- BBC Rear Support
- BBC Bolt Kit



Alternator Brackets Available for Chrysler (CR) & Ford (F)

- AL-9100-CL-CR
- AL-9100-CL-F



Lightweight Billet Aluminum Drive Hubs & Accessories

CNC Machined One & Two Peice Billet Aluminum Drive Hubs, All of our Hubs have built-in Registers & 1/8" Keyways

Billet Drive Hubs for Split-V Pulleys



Billet aluminum drive hub, mounts up to 4 sets of split-v-belt pulleys. Bolts to BBC and SBC balancers. SB Chevy requires DH-3102-ADP. (Page 5)

DH - 3102 - C

Billet aluminum drive hub, mounts up to 3 sets of split-v-belt pulleys. Bolts to BBC and SBC balancers. SB Chevy requires DH-3102-ADP.



DH - 3102 - D

Billet aluminum drive hub, mounts up to 2 sets of split-v-belt pulleys. Bolts to BBC and SBC balancers. SB Chevy requires DH-3102-ADP.



DH - 3102 - A

Billet aluminum drive hub, mounts 1 set of split-v-belt pulleys. Bolts to BBC and SBC balancers. SB Chevy requires DH-3102-ADP.



DH - 3102 - B

SBC Drive Hub for use with DHM-8101 Series Mandrels

Billet aluminum drive hub for SBC balancer. Slides inside of balancer and uses a through bolt and woodruff key to mount. Accepts all DHM-8101 drive mandrels (shown below).



DH-8101-A

SB/BBC Drive Hubs, use w/ DHM Mandrels or WC assem.

SBC & BBC Drive Hub mounts to balancer using 3 bolts and through bolt, DH-8101-C uses any of our DHM-8101 Drive Mandrels or DH-8101-C-DP accepts all of our Dual Dowel Components.

DH-8101-C
DH-8101-C-DP

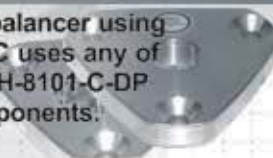

BBC Drive Hub for use with DHM-8101 Series Mandrels

Billet aluminum drive hub for BBC balancer. This setup uses two roll pins along with a through bolt to mount. Hubs accepts all DHM-8101 drive mandrels shown to the right.

DH-8101-B



DH-3102-A or B hub Spacers

Billet aluminum, lightweight, drive hub spacers. Available in 1/4, 1/2 & 3/4" thicknesses, for use with DH-3102-A or B hubs.

SP-3102-WC-1/4"
SP-3102-WC-1/2"
SP-3102-WC-3/4"



Ford 3-Bolt Adaptor

Billet aluminum drive hub adaptor. Bolts to your Ford balancer to allow use of our Chevy drive hubs.

DH-3102-F3-ADP



Crankshaft Nut to Turn Over Engine

Billet Aluminum Drive Hub Nut, to turn over engine.

CSN-6103-1/2"-A



Dual Dowel Drive Hub Extension

Billet drive hub mounts to the front of a DH-3102-A, B, C or D hub to allow the use of a 17 to 22 tooth radius tooth HTD crank shaft pulley or a 12 to 16 tooth square tooth Gilmer pulley.

DH-3101-WC



SBC Hub Adapter

All of our one-piece hubs incorporate a radius at the transition from the base to the shaft adding additional strength and prevents cracking or bending. So each hub is included with a radiused spacer.

SP-8101-A



Drive Hub End Caps

Billet aluminum end caps. The left end cap is for use with a mandrel, the middle is used with a dual dowel pin design setup. The last end cap is also for a dual dowel design and features a built-in nut to turn over your engine.

EC-6111-A (1 1/8" x 7/16") EC-6111-WC-1.280" x 7/16" EC-6111-WC-N x 7/16"
EC-6111-B (1 1/8" x 1/2") EC-6111-WC-1.280" x 1/2" EC-6111-WC-N x 1/2"
EC-6111-C (1 x 7/16")
EC-6111-D (1 x 1/2")

DHM-8101 Drive Mandrels

Billet aluminum Drive Mandrels. Using left hand threads and a through bolt, the mandrel mounts onto one of the four accomodating hubs shown above.

DHM-8101-A 1.250" x 1.125 O.D.
DHM-8101-B 3.500" x 1.125 O.D.
DHM-8101-C 4.000" x 1.125 O.D.
DHM-8101-D 4.500" x 1.125 O.D.
DHM-8101-E 5.000" x 1.125 O.D.
DHM-8101-G 4.000" x 1.000 O.D.



Lightweight Billet Aluminum Drive Hubs & Accessories

CNC Machined One Piece Billet Aluminum Drive Hubs, All of our Hubs have built-in Registers & 1/8" Keyways

SBC Drive Hub (2" Long, Built-in spacer & Nut)



2 inch long, 1 1/8" O.D. drive mandrel, with built-in spacer. This hub features a built-in nut to turn over the engine. Mounts with a through bolt and woodruff key inside the I.D. of your SBC balancer.

DH-8101-NE-A-2.5"

Ford 3-bolt Drive Hub



3.5" long drive mandrel. This hub mounts with 3 bolts and a machined O.D. boss registers the hub to your 3-bolt Ford balancer. This hub uses a self contained bolt & end cap to secure the pulleys.

DH-8101-WC-F3-3.5"

SBC Drive Hub (2.5" Long, Built-in spacer & Nut)



3.625 inch long, 1 1/8" O.D. drive mandrel, with built-in spacer. This hub features a built-in nut to turn over the engine. Mounts with a through bolt and woodruff key inside the I.D. of your SB Chevy balancer.

DH-8101-NE-B-2.5"

Ford 351 Winsor 4-bolt Drive Hub



3" long drive mandrel. This hub mounts with 4 bolts & a machined I.D. bore to register on the Ford 351 4-bolt balancer. This hub uses a self contained bolt and end cap to secure your drive pulleys.

DH-8101-351W-F4

SBC Drive Hub (4.0" Long with Built-in Nut)



4 inch long, 1 1/8" O.D. drive mandrel. This hub features a built-in nut to turn over the engine. Mounts with a through bolt and woodruff key inside the I.D. of your SBC balancer.

DH-8101-NE-C-4.00"

Ford 460 Drive Hub



3" long drive mandrel. This hub mounts with 4 bolts and a machined I.D. bore to register on the Ford 460 4-bolt balancer. This hub uses a self contained bolt & end cap to secure your drive pulleys.

DH-8101-WC-F4-460

Chrysler 6-Bolt Drive Hub



3 1/4" Long mandrel. Mounts with 3 bolts and a machined I.D. bore registers the hub to the Chrysler balancer. This hub uses a self contained bolt and end cap to secure your drive pulleys.

DH-8101-WC-C

BBC & SBC, 3-bolt Drive Hub



3 1/2" long drive hub, mounts with 3 bolts and uses a self contained bolt and end cap to secure your drive pulleys. The BBC has a built-in boss that registers the hub to the balancer, small block Chevys requires the DH-8101-ADP-SB balancer adaptor.

DH-8101-WC-BB & SB
(Shown Below)

Drive Hub for BBC & Ford 3-Bolt Balancers



1 9/16" long (DE) 2 1/16" long (SR) drive hubs. Mounts with three bolts and a machined O.D. boss to register the hub to the Ford & Chevy balancers. These hubs use a self contained bolt and end cap to secure your drive pulleys.

DH-8101-WC-DE
DH-8101-WC-SR

Drive Hub Spacer and Adaptor



Adaptor to convert a SBC drive hub to fit to a BBC Balancer **DH-3102-ADP**



DH-8101-ADP-SB
Billet aluminum balcer adaptor, converts a hub from a BB Chevy to a SB Chevy.



Drive Hub Spacer, Bolts , Keys, Roll Pins & Related Accessories

7/16" & 1/2" Fine-thread bolts supplied with an end cap and locking washer



BEC - 2109 - A (7/16 x 4.0")	BEC - 2109 - H (1/2 x 4.0")
BEC - 2109 - B (7/16 x 4.5")	BEC - 2109 - I (1/2 x 4.5")
BEC - 2109 - C (7/16 x 5.0")	BEC - 2109 - J (1/2 x 5.0")
BEC - 2109 - D (7/16 x 5.5")	BEC - 2109 - K (1/2 x 5.5")
BEC - 2109 - E (7/16 x 6.0")	BEC - 2109 - L (1/2 x 6.0")
BEC - 2109 - F (7/16 x 6.5")	BEC - 2109 - M (1/2 x 6.5")
BEC - 2109 - G (7/16 x 7.0")	BEC - 2109 - N (1/2 x 7.0")

SP - 6103 Series Drive Hub Spacers

Available in "A" (1 1/8" Bore) & "B" (1" Bore)

SP - 6103 - A - A or B 1/4"
 SP - 6103 - B - A or B 3/8"
 SP - 6103 - C - A or B 1/2"
 SP - 6103 - D - A or B 3/4"
 SP - 6103 - E - A or B 1"
 SP - 6103 - F - A or B 1 1/4"
 SP - 6103 - K - (Spacer Kit)



3/16" Roll Pin for BBC Hub DH-8101-B



RP - 2109 - C (set of 2)

SP - 6103 Series Drive Hub Spacers

Used with "WC" Dual Dowel Pin Assemblies

SP - 6103 - WC - A 3/4"
 SP - 6103 - WC - B 1"
 SP - 6103 - WC - C 1 1/4"
 SP - 6103 - WC - D 1 1/2"
 SP - 6103 - WC - E 1"
 SP - 6103 - WC - F 1 1/4"
 SP - 6103 - WC - K - Spacer Kit



3/16" Dowel Pin for Dual Dowel Pin Pulleys



DP - 2109 - A (set of 2)

Drive Hub Mounting-Bolts Kit

Flat Head Bolts:

SK - 2109 - A - 3/8 x 1/2" USS
 SK - 2109 - C - 3/8 x 1" USS
 SK - 2109 - D - 3/8 x 1 1/2" USS
 SK - 2109 - E - 3/8 x 1 1/2" USS
 SK - 2109 - F - 3/8 x 1 1/4" USS
 SK - 2109 - G - 3/8 x 2" USS
 SK - 2109 - H - 3/8 x 2 1/2" USS
 SK - 2109 - I - 3/8 x 3" USS
 SK - 2109 - J - 3/8 x 1" Fine
 SK - 2109 - K - 3/8 x 1 1/4" Fine
 SK - 2109 - L - 3/8 x 1 1/2" Fine



3/16" Woodruff Key for SBC Hub DH-8101-A



WK-6113-A \$2.99

Drive Hub Mounting-Bolts

Socket Head Cap Screw:

SK - 2109 - E 5/16" x 1 1/2" USS
 SK - 2109 - F 5/16" x 2" USS
 SK - 2109 - WC - A 3/8" x 2 1/4" Fine
 SK - 2109 - WC - B 3/8" x 2 1/4" USS



3/16" Key for OP, FP, & VP Pulleys



KS-2109-A (1" Long)

Water Pump Mounting-Bolts

Flat Head (top), Button Head (middle), & Hex Head (bottom) shown.

WP - 2109 - A 2 - Flat Head 5/16" x 1 1/2" Fine
 WP - 2109 - B 4 - Button Head 5/16" x 1" Fine
 WP - 2109 - C 4 - Hex Head 5/16" x 1 1/4" Fine



1/8" Key for Crankshaft Pulleys



KS-2109-B (1" Long)
 KS-2109-C (3/4" Long)
 KS-2109-D (1/2" Long)

Lightweight Billet Aluminum V-Belt Crankshaft Components

Aluminum Split-V V-Belt Pulleys, Single and Double Groove V-Belt Pulleys, and Drive Hubs for WC, Split-V & Mandrels

Split-V Crankshaft Pulleys



Billet aluminum split-v (2 piece) crankshaft pulleys. Allows individual adjustment for tensioning dual v-belt drive systems

- CS - 3102 - WC - D 5.200" O.D.
- CS - 3102 - WC - E 5.500" O.D.
- CS - 3102 - WC - F 5.750" O.D.
- CS - 3102 - WC - G 6.000" O.D.
- CS - 3102 - WC - H 7.500" O.D.

Billet Drive Hubs for Split-V Pulleys



Billet aluminum drive hub, mounts up to 4 sets of split-v-belt pulleys. Bolts to BBC and SBC balancers. SB Chevy requires DH-3102-ADP. (Page 5)

DH - 3102 - C

Single-V Crankshaft Pulleys



Single V-Belt, billet aluminum, crank shaft pulley. One piece, capable of mounting on a drive hub, mandrel or bolt it directly to your Chevy balancer.

CS - 3102 - C 5.000" O.D.

Billet aluminum drive hub, mounts up to 3 sets of split-v-belt pulleys. Bolts to BBC and SBC balancers. SB Chevy requires DH-3102-ADP.

DH - 3102 - D



Double-V Crankshaft Pulleys (Chrysler)



Double-V-belt, billet aluminum, crank shaft pulley, one piece, mounts on Dual Dowel "WC" drive hub or drive mandrel. It will also bolt directly to a chrysler balancer.

CS - 3102 - CH 5.200" O.D.

Billet aluminum drive hub, mounts up to 2 sets of split-v-belt pulleys. Bolts to BBC and SBC balancers. SB Chevy requires DH-3102-ADP.



DH - 3102 - A

Double-V Crankshaft Pulleys (SBC)



Double-V crank shaft pulley with built-in hub for Dual Dowel pin "WC" pulleys or DHM - 8101 drive mandrels, mounts to Small Block Chevy balancer.

- CS - 3102 - WC - B - 5.500" O.D.
- CS - 3102 - WC - A - 6.000" O.D.

Billet aluminum drive hub, mounts 1 set of split-v-belt pulleys. Bolts to BBC and SBC balancers. SB Chevy requires DH-3102-ADP.

DH - 3102 - B



Single-V Crankshaft Pulleys



Billet aluminum Single-V crankshaft pulleys. Available in 1 1/8" & 1" I.D. and dual dowel pin mounting.

- CS - 3102 - A (3.000" O.D., 1.125" Bore)
- CS - 3102 - B (3.000" O.D., 1.000" Bore)
- CS - 3102 - WC (3.000" O.D., Dual Dowel)

Chevy Drive hub, Dual Dowel & DHM



SBC & BBC Drive Hub mounts to balancer using 3 bolts and through bolt, DH-8101-C uses any of our DHM-8101 Drive Mandrels or DH-8101-C-DP accepts all of our Dual Dowel Components.

- DH - 8101 - C
- DH - 8101 - C-DP

Shims for Split-V Pulleys



- DHS-3102-SK-B 6-.020" Shims
- DHS-3102-SK-C 3-.020" Shims
- DHS-3102-SK-D 1-.060" Shim
- DHS-3102-SK-BC 6-.020" Shims & 1-.060" Shims

Drive Hub Spacers

Billet aluminum, lightweight, drive hub spacers. Available in 1/4, 1/2 and 3/4" widths, for use with DH-3102 hubs.

- SP-3101-WC-1/4"
- SP-3101-WC-1/2"
- SP-3101-WC-3/4"



Lightweight Billet Aluminum Square Tooth Crankshaft Components

CNC Machined Billet Aluminum Square Tooth Gilmer CS Pulleys, 1" & .5" Wide, Available for Madrels & WC Assemblies

1" wide, 1/4" bore (A) Square Tooth Gilmer CS pulleys

- CS-4102-A-12, 12 teeth, 1 1/8" I.D.
- CS-4102-A-14, 14 teeth, 1 1/8" I.D.
- CS-4102-A-15, 15 teeth, 1 1/8" I.D.
- CS-4102-A-16, 16 teeth, 1 1/8" I.D.
- CS-4102-A-17, 17 teeth, 1 1/8" I.D.
- CS-4102-A-18, 18 teeth, 1 1/8" I.D.
- CS-4102-A-19, 19 teeth, 1 1/8" I.D.
- CS-4102-A-20, 20 teeth, 1 1/8" I.D.
- CS-4102-A-21, 21 teeth, 1 1/8" I.D.
- CS-4102-A-26, 26 teeth, 1 1/8" I.D.



1/2" wide, 1/4" bore (A) Square Tooth Gilmer CS Pulleys

- CS-4102-AC-12, 12 teeth, 1 1/8" I.D.
- CS-4102-AC-14, 14 teeth, 1 1/8" I.D.
- CS-4102-AC-15, 15 teeth, 1 1/8" I.D.
- CS-4102-AC-16, 16 teeth, 1 1/8" I.D.
- CS-4102-AC-17, 17 teeth, 1 1/8" I.D.
- CS-4102-AC-18, 18 teeth, 1 1/8" I.D.
- CS-4102-AC-19, 19 teeth, 1 1/8" I.D.
- CS-4102-AC-20, 20 teeth, 1 1/8" I.D.
- CS-4102-AC-21, 21 teeth, 1 1/8" I.D.
- CS-4102-AC-26, 26 teeth, 1 1/8" I.D.



1" wide, 1" bore (B) Square Tooth Gilmer CS Pulleys

- CS-4102-B-12, 12 teeth, 1" I.D.
- CS-4102-B-14, 14 teeth, 1" I.D.
- CS-4102-B-15, 15 teeth, 1" I.D.
- CS-4102-B-16, 16 teeth, 1" I.D.
- CS-4102-B-17, 17 teeth, 1" I.D.
- CS-4102-B-18, 18 teeth, 1" I.D.
- CS-4102-B-19, 19 teeth, 1" I.D.
- CS-4102-B-20, 20 teeth, 1" I.D.
- CS-4102-B-21, 21 teeth, 1" I.D.
- CS-4102-B-26, 26 teeth, 1" I.D.



1/2" wide, 1" bore (B) Square Tooth Gilmer CS Pulleys

- CS-4102-BC-12, 12 teeth, 1" I.D.
- CS-4102-BC-14, 14 teeth, 1" I.D.
- CS-4102-BC-15, 15 teeth, 1" I.D.
- CS-4102-BC-16, 16 teeth, 1" I.D.
- CS-4102-BC-17, 17 teeth, 1" I.D.
- CS-4102-BC-18, 18 teeth, 1" I.D.
- CS-4102-BC-19, 19 teeth, 1" I.D.
- CS-4102-BC-20, 20 teeth, 1" I.D.



1" wide, Dual Dowel WC Square Tooth Gilmer CS Pulleys

- CS-4102-WC-16, 16 teeth
- CS-4102-WC-17, 17 teeth
- CS-4102-WC-18, 18 teeth
- CS-4102-WC-19, 19 teeth
- CS-4102-WC-20, 20 teeth



1/2" wide, Dual Dowel Pin WC Square Tooth Gilmer CS Pulleys

- CS-4102-WC-C-16, 16 teeth
- CS-4102-WC-C-17, 17 teeth
- CS-4102-WC-C-18, 18 teeth
- CS-4102-WC-C-19, 19 teeth
- CS-4102-WC-C-20, 20 teeth



Aluminum belt guides for crank shaft pulleys

	Radius Tooth	Square Tooth
BG-6108-A	2.625" O.D. fits 17-26 (1.125" Bore)	12-22 (1.125" Bore)
BG-6108-B	2.625" O.D. fits 17-26 (1.000" Bore)	12-22 (1.000" Bore)
BG-6108-C	3.500" O.D. fits 27-35 (1.125" Bore)	23-28 (1.125" Bore)
BG-6108-D	3.500" O.D. fits 27-35 (1.000" Bore)	23-28 (1.000" Bore)
BG-6108-E	4.000" O.D. fits 36-40 (1.125" Bore)	28-32 (1.125" Bore)

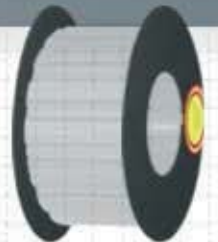

BG-6108-WC



BG-6108-WC is an aluminum removable & reusable belt guide for Dual Dowel, 'WC' crankshaft pulleys. It mounts utilizing the existing two dowel pins connecting the drive assembly. Easy to install & is designed to be durable yet lightweight!



Lightweight Billet Serpentine Poly-V Crankshaft Pulleys

Serpentine Crankshaft Pulleys, Pulleys are deigned for 5 Groove Belts, but have an extra groove for alignment

Lightweight billet aluminum, 6-Groove, 1 1/8" bore, Serpentine Poly-V crank shaft pulleys

CS-5102-AA	2.000" O.D., 1 1/8" I.D.
CS-5102-A	2.500" O.D., 1 1/8" I.D.
CS-5102-B	2.800" O.D., 1 1/8" I.D.
CS-5102-C	3.000" O.D., 1 1/8" I.D.
CS-5102-D	3.250" O.D., 1 1/8" I.D.
CS-5102-E	3.500" O.D., 1 1/8" I.D.
CS-5102-F	3.750" O.D., 1 1/8" I.D.
CS-5102-G	4.000" O.D., 1 1/8" I.D.
CS-5102-H	4.250" O.D., 1 1/8" I.D.
CS-5102-I	4.500" O.D., 1 1/8" I.D.
CS-5102-J	5.000" O.D., 1 1/8" I.D.
CS-5102-K	5.500" O.D., 1 1/8" I.D.
CS-5102-L	6.000" O.D., 1 1/8" I.D.



Lightweight billet aluminum, 6-Groove, Dual Dowel Pin, Serpentine Poly-V crank shaft pulleys

CS-5102-C-WC	3.000" O.D.
CS-5102-D-WC	3.250" O.D.
CS-5102-E-WC	3.500" O.D.
CS-5102-F-WC	3.750" O.D.
CS-5102-G-WC	4.000" O.D.
CS-5102-H-WC	4.250" O.D.
CS-5102-I-WC	4.500" O.D.
CS-5102-J-WC	5.000" O.D.
CS-5102-K-WC	5.500" O.D.
CS-5102-L-WC	6.000" O.D.



SP - 6103 Series Drive Hub Spacers

Available in "A" (1 1/8" Bore) & "B" (1" Bore)

SP - 6103 - A - A or B	1/4"
SP - 6103 - B - A or B	3/8"
SP - 6103 - C - A or B	1/2"
SP - 6103 - D - A or B	5/8"
SP - 6103 - E - A or B	1"
SP - 6103 - F - A or B	1 1/4"
SP - 6103 - K	(Spacer Kit)



Serpentine vs. V-Belt

At Jones Racing Products we know how hard you strive to get every horsepower. This is why we create our drives with efficiency being our top priority. All of our components are made as light as possible. This reduces the moment of inertia (the force required to set an object in motion). When comparing a V-belt and serpentine drive, keep in mind the inertia of an object is greatly reduced as the diameter is decreased. This saves horsepower! Power is also saved due to the reduced amount of frictional resistance. A serpentine drive requires only half the tension of a V-belt drive. This will increase your pulley and belt life, 3 to 1 over v-belt, while reducing the extra strain on the main bearings, water pump, power steering pump or any other accessories you might be running. A serpentine drive is also less expensive due to the reduced amount of material required to machine it.

SP - 6103 Series Drive Hub Spacers

Used with "WC" Dual Dowel Pin Assemblies

SP - 6103 - WC - A	1/4"
SP - 6103 - WC - B	3/8"
SP - 6103 - WC - C	1/2"
SP - 6103 - WC - D	5/8"
SP - 6103 - WC - E	1"
SP - 6103 - WC - F	1 1/4"
SP - 6103 - WC - K	(Spacer Kit)



1/8" Key Stock for Crank Shaft Pulleys

KS-2109-B (1" Long)



3/16" Dowel Pin for Dual Dowel Pin Pulleys

DP-2109-A (set of two)



Lightweight Billet Aluminum Radius Tooth Crankshaft Components

CNC Machined Billet Aluminum Radius Tooth HTD CS Pulleys, 1", .825" & .5" Wide, Available for Madrels & WC Assemblies

Radius Tooth HTD CS Pulleys 1" wide, 1 1/8" bore (A)

CS-6102-A-17, 17 teeth, 1 1/8" I.D.
 CS-6102-A-18, 18 teeth, 1 1/8" I.D.
 CS-6102-A-19, 19 teeth, 1 1/8" I.D.
 CS-6102-A-20, 20 teeth, 1 1/8" I.D.
 CS-6102-A-21, 21 teeth, 1 1/8" I.D.
 CS-6102-A-22, 22 teeth, 1 1/8" I.D.
 CS-6102-A-23, 23 teeth, 1 1/8" I.D.
 CS-6102-A-24, 24 teeth, 1 1/8" I.D.
 CS-6102-A-25, 25 teeth, 1 1/8" I.D.
 CS-6102-A-26, 26 teeth, 1 1/8" I.D.
 CS-6102-A-27, 27 teeth, 1 1/8" I.D.
 CS-6102-A-28, 28 teeth, 1 1/8" I.D.
 CS-6102-A-30, 30 teeth, 1 1/8" I.D.
 CS-6102-A-31, 31 teeth, 1 1/8" I.D.
 CS-6102-A-37, 37 teeth, 1 1/8" I.D.
 CS-6102-A-38, 38 teeth, 1 1/8" I.D.



Radius Tooth HTD CS Pulleys 1/2" wide, 1 1/8" bore (AC)

CS-6102-AC-17, 17 teeth, 1 1/8" I.D.
 CS-6102-AC-18, 18 teeth, 1 1/8" I.D.
 CS-6102-AC-19, 19 teeth, 1 1/8" I.D.
 CS-6102-AC-20, 20 teeth, 1 1/8" I.D.
 CS-6102-AC-21, 21 teeth, 1 1/8" I.D.
 CS-6102-AC-22, 22 teeth, 1 1/8" I.D.
 CS-6102-AC-23, 23 teeth, 1 1/8" I.D.
 CS-6102-AC-24, 24 teeth, 1 1/8" I.D.
 CS-6102-AC-25, 25 teeth, 1 1/8" I.D.
 CS-6102-AC-35, 35 teeth, 1 1/8" I.D.
 CS-6102-AC-36, 36 teeth, 1 1/8" I.D.
 CS-6102-AC-37, 37 teeth, 1 1/8" I.D.
 CS-6102-AC-38, 38 teeth, 1 1/8" I.D.
 CS-6102-AC-40, 40 teeth, 1 1/8" I.D.
 CS-6102-AC-45, 45 teeth, 1 1/8" I.D.



Radius Tooth HTD CS Pulleys 1" wide, 1" bore (B)

CS-6102-B-17, 17 teeth, 1" I.D.
 CS-6102-B-18, 18 teeth, 1" I.D.
 CS-6102-B-19, 19 teeth, 1" I.D.
 CS-6102-B-20, 20 teeth, 1" I.D.
 CS-6102-B-21, 21 teeth, 1" I.D.
 CS-6102-B-22, 22 teeth, 1" I.D.
 CS-6102-B-23, 23 teeth, 1" I.D.
 CS-6102-B-24, 24 teeth, 1" I.D.
 CS-6102-B-25, 25 teeth, 1" I.D.
 CS-6102-B-26, 26 teeth, 1" I.D.
 CS-6102-B-27, 27 teeth, 1" I.D.



Radius Tooth HTD CS Pulleys .825" wide, 1 1/8" bore (AS)

CS-6102-AS-17, 17 teeth, 1 1/8" I.D.
 CS-6102-AS-18, 18 teeth, 1 1/8" I.D.
 CS-6102-AS-19, 19 teeth, 1 1/8" I.D.
 CS-6102-AS-20, 20 teeth, 1 1/8" I.D.
 CS-6102-AS-21, 21 teeth, 1 1/8" I.D.
 CS-6102-AS-22, 22 teeth, 1 1/8" I.D.
 CS-6102-AS-23, 23 teeth, 1 1/8" I.D.
 CS-6102-AS-24, 24 teeth, 1 1/8" I.D.
 CS-6102-AS-25, 25 teeth, 1 1/8" I.D.
 CS-6102-AS-27, 27 teeth, 1 1/8" I.D.
 CS-6102-AS-29, 29 teeth, 1 1/8" I.D.
 CS-6102-AS-30, 30 teeth, 1 1/8" I.D.
 CS-6102-AS-31, 31 teeth, 1 1/8" I.D.
 CS-6102-AS-32, 32 teeth, 1 1/8" I.D.
 CS-6102-AS-33, 33 teeth, 1 1/8" I.D.
 CS-6102-AS-34, 34 teeth, 1 1/8" I.D.
 CS-6102-AS-36, 36 teeth, 1 1/8" I.D.
 CS-6102-AS-37, 37 teeth, 1 1/8" I.D.
 CS-6102-AS-38, 38 teeth, 1 1/8" I.D.
 CS-6102-AS-40, 40 teeth, 1 1/8" I.D.
 CS-6102-AS-44, 44 teeth, 1 1/8" I.D.
 CS-6102-AS-45, 45 teeth, 1 1/8" I.D.



Radius Tooth HTD CS Pulleys .825" wide, 1" bore (BS)

CS-6102-BS-17, 17 teeth, 1" I.D.
 CS-6102-BS-18, 18 teeth, 1" I.D.
 CS-6102-BS-19, 19 teeth, 1" I.D.
 CS-6102-BS-20, 20 teeth, 1" I.D.
 CS-6102-BS-21, 21 teeth, 1" I.D.
 CS-6102-BS-22, 22 teeth, 1" I.D.
 CS-6102-BS-30, 30 teeth, 1" I.D.
 CS-6102-BS-31, 31 teeth, 1" I.D.
 CS-6102-BS-32, 32 teeth, 1" I.D.
 CS-6102-BS-33, 33 teeth, 1" I.D.
 CS-6102-BS-34, 34 teeth, 1" I.D.
 CS-6102-BS-38, 38 teeth, 1" I.D.



Radius Tooth CS Pulleys 1/2" wide, Dual Dowel WC

CS-6102-WC-C-22, 22 teeth
 CS-6102-WC-C-23, 23 teeth
 CS-6102-WC-C-24, 24 teeth
 CS-6102-WC-C-26, 26 teeth



Radius Tooth CS Pulleys .825" wide, Dual Dowel Pin WC

CS-6102-WC-22, 22 teeth
 CS-6102-WC-23, 23 teeth
 CS-6102-WC-24, 24 teeth
 CS-6102-WC-25, 25 teeth
 CS-6102-WC-26, 26 teeth



Radius Tooth HTD CS Pulleys 1/2" wide, 1" bore (BC)

CS-6102-BC-17, 17 teeth, 1" I.D.
 CS-6102-BC-18, 18 teeth, 1" I.D.
 CS-6102-BC-19, 19 teeth, 1" I.D.
 CS-6102-BC-20, 20 teeth, 1" I.D.
 CS-6102-BC-21, 21 teeth, 1" I.D.
 CS-6102-BC-22, 22 teeth, 1" I.D.
 CS-6102-BC-23, 23 teeth, 1" I.D.
 CS-6102-BC-24, 24 teeth, 1" I.D.
 CS-6102-BC-25, 25 teeth, 1" I.D.
 CS-6102-BC-40, 40 teeth, 1" I.D.



Dual Dowel Drive Hub for 17-22 Pulleys

Billet Hub that mounts to the front of a DH-3102-A, B or C hub to allow the use of 17-22 tooth Radius Tooth HTD Crankshaft pulleys or 12-16 tooth Square Tooth Gilmer pulley.



3/16" Dowel Pin for Dual Dowel Pin Pulleys

DP-2109-A



DH-3102-C

Fuel Pumps and Billet Aluminum Fuel Pump Pulleys

Available for Gas and Alcohol, Pulleys are made from Billet Aluminum & Hard Coated to Ensure a Long Life

Billet Aluminum, Lightweight, Radius Tooth HTD

Fuel Pump pulleys. .625" bore, 1" wide, uses 3/16 key and 5 set screws to mount.

- FP-6106-40-1"
- FP-6106-42-1"
- FP-6106-44-1"
- FP-6106-48-1"



Fuel Pump Mounting Options



Billet Aluminum, Lightweight, Radius Tooth HTD

Fuel Pump pulleys. .625" bore, 1/2" wide, uses 3/16 key and 3 set screws to mount.

- FP-6108-36-1/2"
- FP-6108-38-1/2"
- FP-6108-40-1/2"
- FP-6108-44-1/2"



Billet Aluminum, Lightweight, Square Tooth Gilmer

Fuel Pump pulleys. .625" bore, 1" wide, uses 3/16 key and 5 set screws to mount.

- FP-4106-26-SQ
- FP-4106-28-SQ
- FP-4106-30-SQ
- FP-4106-32-SQ
- FP-4106-34-SQ



Belt driven Fuel Pump for Alcohol or Gas

Featuring an adjusting arm which rotates around the pump 360. Provided with a one year manufacturers warranty.

- FP - 8009 - A



Combination Fuel & Power Steering Tandem Pump

Belt driven fuel and power steering combination tandem pump. Its unique design saves horsepower & provides a better overall efficiency while delivering a smooth, uniform flow, incorporated with an increased priming-efficiency design.

- KSE - 8009 - C



Billet Aluminum Lightweight Belt Guides.

Available for corresponding Fuel Pump and Oil Pump pulleys.

- BG-6108-30SQ
- BG-6108-38
- BG-6108-44
- BG-6108-32SQ
- BG-6108-36
- BG-6108-44
- BG-6108-34SQ
- BG-6108-40
- BG-6108-46
- BG-6108-35
- BG-6108-42



Lightweight Billet Aluminum 1/2" Thick Fuel Pump Brackets

Available for BBC, SBC, Chrysler and Ford; All Brackets are Supplied with mounting bolts and necessary spacers

Small Block Chevy lightweight KSE Fuel & Power Steering combination pump mounts. Both mount to water Pump.



(Short mount)
FP-9100-B

(Regular mount)
FP-9100-C



Small block Ford lightweight KSE fuel & power steering combination tandem pump mount. Mounts to water pump.



FP-9100-A



Small Block Chrysler fuel pump mount. Mounts fuel pump to stock location on timing cover.



FP-9100-F



SB Chevy Fuel Pump mount, Mounts Fuel Pump on either side of the water pump, allows horizontal adjustment.



FP-9100-D



SB Chevy Fuel Pump mount, Mounts Fuel Pump to either side of the water pump & allows vertical adjustment.



FP-9100-E-SB



BB Chevy Fuel Pump mount, Mounts Fuel Pump to either side of the water pump & allows vertical adjustment.



FP-9100-E-BB



Lightweight Billet Aluminum OP Pulleys & Accessories

Lightweight Billet Aluminum Oil Pump Pulleys, Locking Collets, Belt Guides, and Oil/Fuel Pump Promers

Lightweight billet aluminum, Radius Tooth HTD, oil pump pulleys, .625" I.D.

Each pulley has a 5/8" I.D. and mounts with a 3/16" key and five set screws. Our Radius Tooth HTD design requires only 6 pounds of tension using either our 20mm wide or 30mm wide belt, thus saving valuable horsepower while reducing wear on your components. 1 1/4" wide oil pump pulleys feature a 1/4" radiused front making it easier to slide the belt on and off the pulley to prime your oil system.

1 1/4" Wide:



- OP-6103-28-1 1/4" OP-6103-37-1 1/4"
- OP-6103-30-1 1/4" OP-6103-38-1 1/4"
- OP-6103-32-1 1/4" OP-6103-40-1 1/4"
- OP-6103-33-1 1/4" OP-6103-45-1 1/4"
- OP-6103-34-1 1/4" OP-6103-46-1 1/4"
- OP-6103-35-1 1/4" OP-6103-47-1 1/4"
- OP-6103-36-1 1/4" OP-6103-48-1 1/4"
- OP-6103-56-1 1/4"

1" Wide:



- OP-6103-40-1"
- OP-6103-42-1"
- OP-6103-44-1"
- OP-6103-48-1"

Lightweight billet aluminum, Radius Tooth HTD, Oil Pump Pulley with an I.D. to accept Locking Collets

This pulley features all of the advantages of the above pulleys in a 1 1/4" wide design and utilizes our locking collar design which adapts your pulley to fit any shaft size weather it be a unique .590" shaft standard 5/8" shaft a smaller .5" shaft.



- OP-6103-30-1 1/4"-C
- OP-6103-32-1 1/4"-C
- OP-6103-34-1 1/4"-C
- OP-6103-36-1 1/4"-C
- OP-6103-38-1 1/4"-C
- OP-6103-40-1 1/4"-C

.500", .590", & .625" Locking Collets for use with 1" or 1 1/4" pulleys



- | | | |
|-------------|---------------|-------------------------------------|
| OP-437x7/8" | Torque specs: | 175 in-lbs. (15 ft-lbs or 19.8 n-m) |
| OP-500 x 1" | | 175 in-lbs. (15 ft-lbs or 19.8 n-m) |
| OP-590 x 1" | | 200 in-lbs. (17 ft-lbs or 22.6 n-m) |
| OP-625 x 1" | | 200 in-lbs. (17 ft-lbs or 22.6 n-m) |

Precision made locking collets designed for use with out 1 1/4" wide Radius Tooth oil pump pulleys with a 1" bore. Available to fit either a .590" (15mm) shaft or a .625" (5/8") oil pump shaft.

Lightweight billet aluminum, Square Tooth Gilmer Oil Pump pulleys, .625" I.D.

All of our Sqaure Tooth oil pump pulleys have a 5/8" I.D. and mount using a 3/16" key and five set screws. A 1" bore for use of the locking collar is available via special order. Our Gilmer oil pump pulleys have a 1/4" radiused front to prevent damage to the belt & to make it easier to remove the belt for priming.



- OP-4103-26-SQ
- OP-4103-28-SQ
- OP-4103-30-SQ
- OP-4103-32-SQ
- OP-4103-34-SQ

Lightweight billet aluminum removable and reusable belt guides.

Our belt guides register with the pulley's I.D. and mount using 4-10/24 allen bolts in relative lengths. Belt guides are available for every major tooth count.



- BG-6108-35 BG-6108-42
- BG-6108-36 BG-6108-44
- BG-6108-38 BG-6108-45
- BG-6108-40 BG-6108-48

Billet aluminum oil and fuel pump primer. Available for Radius Tooth HTD & Square Tooth Gilmer drive systems.



Primers comes with a stanless steel shaft, our free spinning handle, biliet aluminum pulley, belt guides, and extra long belt. Usable with any 3/8" chucked drill.

- OP-6103-PP
Radius Tooth

- OP-4103-PP
Square Tooth

Billet Aluminum 3, 4, and 5 Stage Oil Pumps and Components

CNC Machined Billet Aluminum Oil Pumps, .625" Shafts, -12 built-in fitting, AN Fittings, Hoses, and Support Coil

Billet aluminum **JOHNSON'S HTP** Oil Pumps

- Highly efficient with no pressure losses
- High vacuum productivity
- Lower operating oil temperatures
- Finned billet design to dissipate heat
- Machined AN fittings engineered into pump housing
- Caged needle-bearings
- Completely doweled and o-ringed construction
- Industry's best warranty



2 Stages for vacuum & 1 stage wet sump

VP-9100-WS



3 Stage Pump



4 Stage Pump



5 Stage Pump



180° Aluminum AN Fittings

- AN-0600-180 -6 180° Alum AN Fitting
- AN-0800-180 -8 180° Alum AN Fitting
- AN-1000-180 -10 180° Alum AN Fitting
- AN-1200-180 -12 180° Alum AN Fitting



150° Aluminum AN Fittings

- AN-0600-150 -6 150° Alum AN Fitting
- AN-0800-150 -8 150° Alum AN Fitting
- AN-1000-150 -10 150° Alum AN Fitting
- AN-1200-150 -12 150° Alum AN Fitting
- AN-1600-150 -16 150° Alum AN Fitting



120° Aluminum AN Fittings

- AN-0600-120 -6 120° Alum AN Fitting
- AN-0800-120 -8 120° Alum AN Fitting
- AN-1000-120 -10 120° Alum AN Fitting
- AN-1200-120 -12 120° Alum AN Fitting
- AN-1600-120 -16 120° Alum AN Fitting



90° Aluminum AN Fittings

- AN-0600-90 -6 90° Aluminum AN Fitting
- AN-0800-90 -8 90° Aluminum AN Fitting
- AN-1000-90 -10 90° Aluminum AN Fitting
- AN-1200-90 -12 90° Aluminum AN Fitting
- AN-1600-90 -16 90° Aluminum AN Fitting



45° Aluminum AN Fittings

- AN-0600-45 -6 45° Aluminum AN Fitting
- AN-0800-45 -8 45° Aluminum AN Fitting
- AN-1000-45 -10 45° Aluminum AN Fitting
- AN-1200-45 -12 45° Aluminum AN Fitting
- AN-1600-45 -16 45° Aluminum AN Fitting



Straight Aluminum AN Fittings

- AN-0600-0 -6 0° Aluminum AN Fitting
- AN-0800-0 -8 0° Aluminum AN Fitting
- AN-1000-0 -10 0° Aluminum AN Fitting
- AN-1200-0 -12 0° Aluminum AN Fitting
- AN-1600-0 -16 0° Aluminum AN Fitting



-4, -6, -8, -10, -12, -16 braided Oil & Water lines



1500 PSI Maximum operating pressure. used for oil, fuel & water lines. Operating temperature range: **-40 F to +300 F**

- AN-0400-SC -4 (1/4") 4ft. Section
- AN-0600-SC -6 (3/8") 4ft. Section
- AN-0800-SC -8 (1/2") 4ft. Section

- AN-0400-SC -10 (5/8") 4ft. Section
- AN-0600-SC -12 (3/4") 4ft. Section
- AN-0800-SC -16 (1") 4ft. Section

Internal support coil for -8, -10, -12 & -16 AN Lines

- AN-0800-SC -8 4ft.
- AN-1000-SC -10 4ft.
- AN-1200-SC -12 4ft.
- AN-1600-SC -16 4ft.

Ensures the braided line's stability on the vacuum side. Guarantees hose to work at 100% of its efficiency.



See page 20 for weld in bungs and 90° swivel fittings

Lightweight Billet Aluminum Oil Pump Brackets

Chevy Bracket allows for verticle adjustment, Chrsyler brackets allows a Chevy's bolt paterned pump to be mounted



Postion - 1

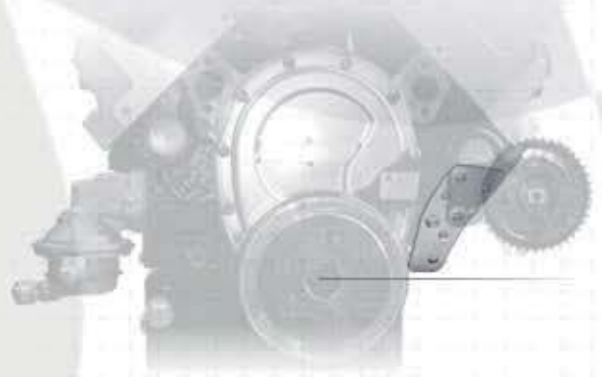

Postion - 2

SB Chevy oil pump bracket, **OP - 9101 - A**, offers extreme versatility on where to mount your oil pump. This bracket is capable of mounting on either the left or right side of the block & allows 3 different locations for the oil pump to mount, making your ideal mounting position easily obtainable. Block mounting bolts included.



Postion - 3



SB Ford oil pump bracket: **OP - 9101 - B** mounts oil pump with chevy bolt pattern to SB Ford.



Aluminum Power Steering Pumps & PS Pump Remote Reservoirs

Aluminum Power Steering Pump Pulleys and Remote Mounting Aluminum PS Pump Reservoir and Replacement Reservoir

Heat Resistant, Lightweight, Large Capacity Reservoir

Compatible with JRP 'PS-9008-AL-R' & 'PS-9008-ST-R' series power steering pumps. Mounts directly to the Pump

PS-9008-R



Aluminum Reservoir

Aluminum, modular, power steering tank with built-in fittings & universal mounting bracket to mount to any size frame rail or the fire wall.

PS-8101-A



Power Steering Fluid

High Performance Anti Foaming Power Steering Fluid. Designed to reduce heat in you system.

QT-8009



Power Steering Pump Press on Hub

Our billet aluminum hub makes it easy to change your power steering pulley. A versatile Dual Dowel mounting configuration to accept all 'WC' crankshaft pulleys. Supplied w/ bolt & end cap kit.

DH-8101-PS



RadiusTooth HTD Power Steering Pulleys

PS-6106-B-33
PS-6106-B-40
PS-6106-B-45
PS-6106-B-48
PS-6106-K-40

Lightweight, billet aluminum, available for press fit (B), see page 26 for installation tool, & keyed (K) style shafts.



Serpentine Poly-V Power Steering Pulleys

PS-5106-B-4.000"
PS-5106-B-4.250"
PS-5106-B-4.500"
PS-5106-B-5.000"
PS-5106-K-4.000"

Lightweight, billet aluminum, provided with an extra groove for ease of alignment available for both press fit (B), see page 26 for tools, and keyed (K) style shafts.



Square Tooth Glimer Power Steering Pulleys

PS-4106-B-28
PS-4106-B-30
PS-4106-B-32

Lightweight, billet aluminum, press fit to the power steering pump's shaft, see page 26 for installation tools.



3/8" to 1/2" V-belt Power Steering Pulleys

PS-3106-B-4.500"
PS-3106-B-5.000"
PS-3106-B-5.500"
PS-3106-B-6.000"
PS-3106-B-6.500"
PS-3106-B-7.000"

Lightweight, billet aluminum, press fit to power steering pump, see page 26 for installation tools.



Power Steering Pumps with or without Built-In Reservoirs

Aluminum or Steel Power Steering Pumps, both pumps are available with or without built-in Reservoirs

Lightweight Aluminum Power Steering Pump with Reservoir

Lightweight Aluminum Power Steering Pump with built-in reservoir holding a generous capacity of 18oz. Ideal for rack and pinion use, great universal pump for street use. Our Pump is able to produce up to 1100 PSI of pressure for ease of steering.

PS - 9008 - AL - R



Lightweight Aluminum Power Steering Pump

Lightweight aluminum power steering pump ideal for rack and pinion use, great universal pump for street use. Our pump is able to produce up to 1100 PSI of pressure for ease of steering. (See page 14 for remote reservoir)

PS - 9008 - AL



Aluminum Reservoir

Aluminum, modular, power steering tank with built-in fittings & universal mounting bracket to mount to any size frame rail or the fire wall.

PS-8101-A



Power Steering Fluid

High Performance Anti Foaming Power Steering Fluid. Designed to reduce heat in your system.

QT-8009



Billet sub-mount, used behind power steering pumps

with built in reservoirs. Allows for proper, vertical orientation of the tank for maximum pump efficiency. 5/16 stud, bolt and mounting accessories included.

PS - 8001 - SM



Lightweight Billet Aluminum 1/2" Thick Power Steering Brackets

Most of our brackets are able to mount on either the left or right side of your engine. The power steering brackets shown below are compatible with JRP & most aftermarket power steering pumps

Billet aluminum Chrysler power steering bracket



PSL - 8001 - C

Mounts to the block by the crank case and the head to prevent flexing. This bracket will work on the left or right side of the engine and is compatible with our and most aftermarket power steering pumps.



Billet aluminum Small Block Chevy power steering bracket



PS - 8001 - SB - DS

Mounts to the block by the crank case and to the head to prevent flexing. This bracket is compatible with all of our and most aftermarket power steering pumps and is designed to clear the dry sump.



Billet aluminum Small Block Chevy or Motor Plate Power Steering bracket



PST - 8001 - F

Mounts to the head or to any motor plate. It is compatible with all of our & most aftermarket power steering pumps.



Billet aluminum Small Block Ford power steering bracket



PSH - 8001 - F

Mounts to 302 and 351 windsor heads on either the left or right side. It is compatible with all of our and most aftermarket power steering pumps.



Billet aluminum Big Block Chevy power steering bracket



PSH - 8001 - BB

Mounts to left or right side of head and is compatible with all of our and most aftermarket power steering pumps.



Billet aluminum Small Block Chevy power steering bracket



PSH - 8001 - C

Mounts to left or right side of head and is compatible with all of our and most aftermarket power steering pumps.



BB & SB Chevy 2-Stage Vacuum Pump Kit 7001-RA

Small or Big Block Chevy, Radius Tooth HTD Driven, Billet Aluminum Vacuum Pump Kit

FP-6106-40-1/2"

Lightweight billet aluminum Radius Tooth HTD 40 tooth Vacuum pump drive pulley. This pulley has a .625" bore & 3/16" keyway & mounts using 5 set screws.

BG-6108-40

Lightweight billet aluminum removable & reusable belt guides. Attach using four 10-24 allen bolts.

CS-6102-AC-20

Lightweight billet aluminum Radius Tooth HTD 20 tooth Crankshaft pulley. 1/2" wide 1 1/8" bore, 1/8" Keyway.

BG-6108-A

Two Lightweight aluminum belt guides for 17-26 Tooth Crankshaft pulleys. 1 1/8" bore, .0625" wide.

640-10

25.197" Long Radius Tooth HTD belt. Many sizes available

AN-1200-B

3 -12 weld in aluminum bungs for vacuum lines & regulator



AN-1200-90S

-12 90° swivel fitting for use with the regulator.



AN-1200-R

-12 Adjustable Vacuum Regulator. Preset to 10"



AN-1200-SC

Four foot of internal support coil to prevent the AN lines from collapsing.



See page 15 for more fittings

Lightweight Billet Aluminum Vacuum Pumps and Accessories

2 Stage Vacuum Pump with an All Billet Aluminum Housing, and Billet Aluminum HTD pulleys and Related Accessories

VP-9107 Series Billet Aluminum, Gear Style, High Efficiency, Vacuum Pump

2-stage billet aluminum, gear style vacuum pump. Engineered for racing, runs at fifty percent of engines RPM to pull 15" of vacuum.

Left side pump:

VP-9100-B

Right side pump:

VP-9100-C

2 Stage Vacuum/1 Stage Wet Sump

VP-9100-WS



VP-9100-WS



VP-9100-C



VP-9100-B

Available for left or right side mounting

All pumps are run with a Radius Tooth HTD drive system to save horsepower increase longevity and eliminate belt slip

All pumps come with a 1 year warranty

VP-6106 Series Radius Tooth HTD Vacuum Pump Pulleys

Lightweight, billet aluminum, Radius Tooth HTD vacuum pump pulleys. 5/8" I.D., mounts with a 3/16 key and 3 set screws. Uses 10mm wide HTD belt (see page 47). Moroso pulleys require DH-9107 hub, shown below and mount with 3 - 1/4" bolts

JRP vacuum pump pulleys:

FP - 6106 - 36 - .5" wide
FP - 6106 - 38 - .5" wide
FP - 6106 - 40 - .5" wide
FP - 6106 - 44 - .5" wide

Moroso vacuum pump pulleys:

VP - 6106 - 36 - .5" wide
VP - 6106 - 40 - .5" wide

*1/2" wide drive pulleys can be found on page 11



3 Bolt Hub Vacuum Pump Pulleys

Vacuum Pump Pulleys with Moroso bolt pattern, 1/2" I.D. and a 3-hole bolt pattern. Availability listed above.



BG-6108 Belt Guides

Lightweight, billet aluminum, removable and reusable, belt guides. Available for all of our vacuum pump pulleys. See pg 24 for a complete list of prices.



VP-9100-BM Vacuum Pump Bracket

Billet aluminum 1/2" thick vacuum pump brackets. Mounts on BB and SBC utilizing the block holes by the crank on either the left or right side. This bracket is compatible with both our vacuum pump and Moroso's.



VP-9100-TM Vacuum Pump Bracket

Billet aluminum, 1/2" thick head mounting, vacuum pump bracket. Mounts on left or right side of Big Block Chevy & is compatible with our vacuum pump and Moroso's.



4' of Internal Support Coil, -8 & larger

AN-0800-SC
AN-1000-SC
AN-1200-SC
AN-1600-SC

Internal support coil ensures the stability of the vacuum line to guarantee 100% efficiency.



FCM-2955-12 3 -12 Alum. AN Fittings



3 Billet aluminum -12 AN fittings. O-ring sealed and radius entry to pump for maximum efficiency.

AN-1200-R



-12 Regulator preset to your desired vacuum

Lightweight Billet Aluminum Water Pump Pulleys & Offset Diagrams

CNC Machined Billet Aluminum Single, Double and Tripple V-Belt Water Pump Pulleys, and related accessories

WP-3104 Series Water Pump Pulleys

Lightweight, billet aluminum, single v-belt design. 2.215" offset from face of water pump hub to center of V.

- WP - 3104 - A - 6" - S.V.
- WP - 3104 - D - 7" - S.V.



Offset Illustration

Below is a diagram showing how we would like you to measure from the balancer face to the water pump hub face. We recommend using a straight edge to rest against the wp hub and then to measure from the face of the balancer to the straight edge.

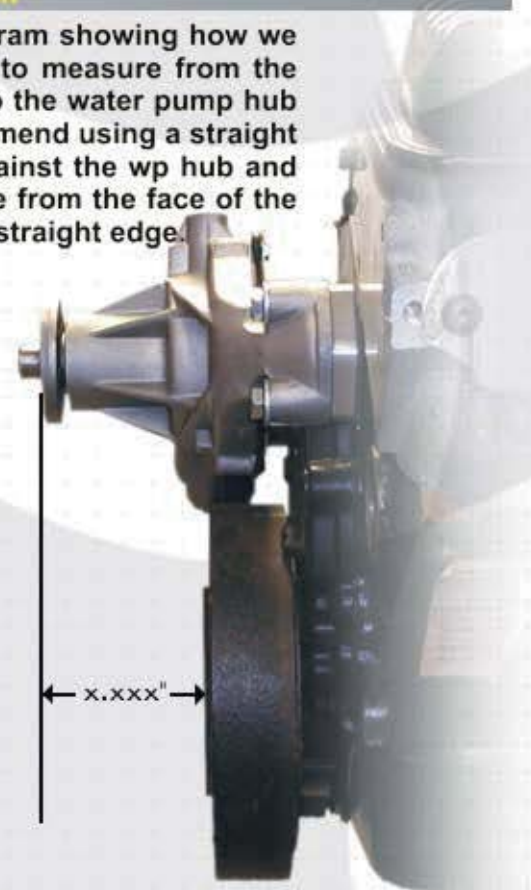

WP-3104 Series Water Pump Pulleys

Lightweight, billet aluminum, double v-belt design. 1.465" offset from face of water pump hub to center of first V, 2.215 to center of second V. .75" to center of third V.

- WP - 3104 - B - 6" D.V.
- WP - 3104 - E - 7" D.V.



WP-3104 Series Water Pump Pulleys

Lightweight, billet aluminum, triple v-belt design. .715" offset from face of water pump hub to center of first V, 1.465" to second V & 2.215" to the center of third V.

- WP - 3104 - F - 7" T.V.



WP-3104 Series Dodge Water Pump Pulleys

Lightweight, billet aluminum, tripple v-belt design for Dodge engines. .715" offset from face of water pump hub to center of first V, 1.465" to second V & 2.215" to the center of third V.

- WP - 3104 - G - 5 7/8" O.D.
- WP - 3104 - H - 7" O.D.



WP-6104 - A

1/16" Water Pump Pulley Shims

Aluminum .0625 (1/16") shim to properly align the water pump pulley. Each shim is made ensuring a flat surface. Available in sets of 3.



WP-6104-B WP Pulley Bushing

Billet aluminum bushing which allows all of our water pump pulleys to work on either a .625 shaft or .750 shaft. Included with pulley purchase.



Offset Clarification

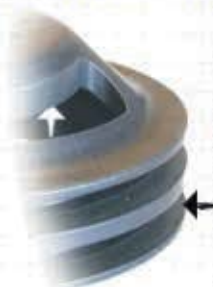

The offset measurement is the distance from the inside-center of the last groove (shown with pointer) to the inside face that sits against the water pump hub, shown with white arrow. This distance can now be compared to the distance from the face of the water pump hub to the face of the balancer to ensure proper belt alignment

WP-6104-C Adapter to Register Fan

Billet aluminum shaft extension for use with WP-9104-32 drive pulley which mounts in front of the water pump pulley. Use this bushing if you are running a mechanical fan to properly register & relocate the fan with the water pump shaft.



Lightweight Billet Aluminum Cog & Serpentine Water Pump Pulleys

CNC Machined Billet Aluminum Radius Tooth HTD and Square Tooth Gilmer Water Pump Pulleys with Offset Numbers

WP-6104 Series Water Pump Pulleys

Lightweight, billet aluminum, Radius Tooth HTD water pump pulley, belt adjustment from 0" to 1.1" with a 20mm wide belt. This measurement is from the face of water pump hub.



- WP-6104-35A
- WP-6104-36A
- WP-6104-37A

WP-5104 Series Water Pump Pulley

Lightweight, billet aluminum, Serpentine Poly-V water pump pulley, .670" offset. Each of our serpentine water pump pulleys has a 7th groove for ease of alignment.



- WP-5104-D-4"

WP-6104 Series Water Pump Pulleys

Lightweight, billet aluminum, Radius Tooth HTD water pump pulley, belt adjustment from 1.85" to 2.0" with a 20mm wide belt.



This measurement is from the face of water pump hub.

- WP-6104-35S
- WP-6104-36S
- WP-6104-37S
- WP-6104-40S

WP-5104 Series Water Pump Pulley

Lightweight, billet aluminum, Serpentine Poly-V water pump pulley, 1.135" offset. Each of our serpentine water pump pulleys has a 7th groove for ease of alignment.



- WP-5104-C-4"

WP-6104 Series Water Pump Pulley

Lightweight, billet aluminum, Radius Tooth HTD water pump pulley, belt adjustment from 1.875" to 2.740" with a 20mm wide belt. This measurement is from the face of water pump hub.



- WP-6104-37-F1 \$96.99

WP-5104 Series Water Pump Pulley

Lightweight, billet aluminum, Serpentine Poly-V water pump pulley, 1.780" offset. Each of our serpentine water pump pulleys has a 7th groove for ease of alignment.



- WP-5104-F-4"

WP-4104 Series Water Pump Pulley

Lightweight, billet aluminum, Square Tooth Gilmer water pump pulley, belt adjustment from 1.8" to 2" with a 1" wide belt. Measured from the face of the water pump hub.



- WP-4104-28SQ
- WP-4104-32SQ

WP-5104 Series Water Pump Pulley

Lightweight, billet aluminum, Serpentine Poly-V water pump pulley, 2.320" offset. Each of our serpentine water pump pulleys has a 7th groove for ease of alignment.



- WP-5104-WC-4.5"
- WP-5104-WC-5"

Offset Clarification

The offset measurement is the distance from the top-center of the last groove (shown with pointer) to the inside face that sits against the water pump hub. This distance can now be compared to the distance from the face of the water pump hub to the face of the balancer to ensure proper belt alignment.



WP-5104 Series Reverse Water Pump Pulley

Lightweight, billet aluminum, reverse serpentine water pump pulley. The reverse WP design offers more flexibility & better belt wrap for unique serpentine drive systems.



- WP-5104-FS-4.0"
- WP-5104-FS-5.5"

WP-6104-B WP Pulley Bushing

Billet aluminum bushing which allows all of our water pump pulleys to work on either a .625 shaft or .750 shaft. Included with pulley purchase.



WP-6104-A

1/16" Water Pump Pulley Shims
Aluminum .0625 (1/16") shim to properly align the water pump pulley. Each shim is made ensuring a flat surface. Available in sets of 3.



Lightweight Billet Removable and Reusable Belt Guides

Billet Aluminum Belt Guides, Hard Coated to ensure wear resistance. Available for all common pulleys

Aluminum belt guides for crank shaft pulleys

	Radius Tooth	Square Tooth
BG - 6108 - A	2.625" O.D. fits 17-26 (1.125" Bore)	12-22 (1.125" Bore)
BG - 6108 - B	2.625" O.D. fits 17-26 (1.000" Bore)	12-22 (1.000" Bore)
BG - 6108 - C	3.500" O.D. fits 27-35 (1.125" Bore)	23-28 (1.125" Bore)
BG - 6108 - D	3.500" O.D. fits 27-35 (1.000" Bore)	23-28 (1.000" Bore)
BG - 6108 - E	4.000" O.D. fits 36-40 (1.125" Bore)	28-32 (1.125" Bore)
BG - 6108 - F	2.500" O.D. fits 17-25 (1.125" Bore)	12-20 (1.125" Bore)
BG - 6108 - G	2.375" O.D. fits 17-24 (1.000" Bore)	12-19 (1.000" Bore)



BG-6108-WC Dual Dowel Crankshaft Pulley Belt Guides



Aluminum removable & reusable belt guide for Dual Dowel, 'WC' crankshaft pulleys. Mount utilizing the existing two dowel pins connecting the drive assembly. Easy to install and designed to be durable yet lightweight!

Removable and Reusable Billet Belt Guides



Lightweight billet aluminum removable & reusable belt guides for oil pump, fuel pump, and vacuum pump pulleys. Our belt guides register with the pulley's I.D. and mount using four 10/24 allen bolts in relative lengths. Belt guides are available for every major tooth count.

- BG-6108-30SQ
- BG-6108-32SQ
- BG-6108-34SQ
- BG-6108-35
- BG-6108-36
- BG-6108-38
- BG-6108-40
- BG-6108-42
- BG-6108-44
- BG-6108-45
- BG-6108-48

Alternator Pulley Belt Guides

- BG - 9108 - C
(32 Tooth HTD)
- BG - 9108 - D
(37 Tooth Gilmer)



Alternator Pulley Belt Guides

- BG - 9108 - A
(24 Tooth, HTD)
- BG - 9108 - B
(20 Tooth, Gilmer)



Alternator Drive Pulley Belt Guide

- BG - 9108 - W



Lightweight Billet Aluminum Accessories

Water Restrictor



Billet Aluminum water restrictor. Jones Racing Products has been manufacturing unique product for over 20 years. This is just one of many popular accessories it is hard to run without. Place our restrictor in your cooling system and cool your engine 20+ degrees.

RR-9104-A

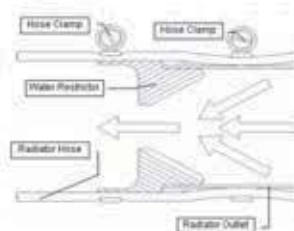

Expansion Tank



Aluminum expansion tank with billet inlet. Fits all Chevy manifolds

EXT-9104-B



Water Outlet Cover



Billet aluminum water outlet cover. This billet aluminum cover covers the water outlet on the intake manifold. Covers are available for small block Chevys, big block Chevys, and Ford 260-351ci. Ideally used when storing or transporting an engine.

WO-9101-A Fits all Chevy Manifolds
WO-9101-B Ford 260-351 ci

Distributor Outlet Cover



Billet aluminum distributor inlet cover. This billet aluminum cover closes the distributor inlet on the intake manifold. Covers works with SB & BB Chevys, and Fords. Ideally used when storing, washing, or transporting an engine.

DE-9101-G

Exhaust Cover Sets



EX-9101-A Small Block Chevy (standard ports)
EX-9101-B Small Block Chevy (spread ports)
EX-9101-C Big Block Chevy
EX-9101-D Small Block Ford (S.V.O.)
EX-9101-E Small Block Ford (260 - 351)
EX-9101-F Small Block Ford with Dart & T.F.S.

Fuel Pump Cover



Billet Aluminum fuel pump cover. Our covers seals off the OEM position for mechanical fuel pump. Ideally used when switching to a belt driven pump like our KSE-9008-C Fuel & Power Steering Tandem Pump or our FP-8009-A high flow fuel pump. Covers available for BB & SB Chevys, Chryslers, and Fords.

SBC - FP - 9100 - A Compatible with **SB Chevy**
BBC - FP - 9101 - B Compatible with **BB Chevy**
BB Chrysler and Ford

Engine Related Accessories & Tools to Get the Most from Your Engine

Spark Plug Inspection Light, Laser Guided Temperature Gun, Spark Plug Indexers, & Wrenched to Turn Over Your Engine

Spark Plug Inspection Light



Spark Plug Inspection Magnifying Glass with 10x magnification built-in light and padded zipper case. Used to inspect the spark plug's electrode.

SP - 8101 - IL

Temperature Gun



TL-8101-L

Laser guided temperature guns, capable of judging temperatures ranging from as cold as -58°F to as hot as 1000°F with the TL-8101-L-HT. All three guns are equipped with a backlit digital readout which is able to display the temperature in Celsius or Fahrenheit. The two larger guns have an 8:1 distance to target ratio, the smaller handheld pocket thermometer has a 6:1 distance to target ratio.

TL-8101-L (0-525° F, 8:1 Distance:Target)
TL-8101-L-HT (0-1000° F, 8:1 Distance:Target)
TL-8101-L-HH (0-518° F, 6:1 Distance:Target)

TL-8101-L-HT

TL-8101-L-HH

Spark Plug Indexer & Plugs



Billet aluminum, one piece spark plug indexer, labeled with the motor's corresponding cylinder number. Shown with a set of 14mm billet aluminum plugs used when storing, washing or changing your engine.

SP - 8101 - V8 - C 8 Hole 1-piece Indexer
SP - 8101 - V8 - D 8 - 14mm Billet Plugs



Spark Plug Indexers



Billet aluminum spark plug indexers with billet adjustable inserts, available in both a 9-hole and 8-hole model. Our indexers make it easy to properly index spark plugs. Just follow our three-step process. Get a 9-hole indexer and do two steps at once! See our spark plug indexing sheet for advantages of indexing.

SP - 8101 - V8 - A 9 Hole indexer
SP - 8101 - V8 - B 8 Hole indexer

Engine Turn-over Wrenches



Billet aluminum wrenches to turn over engine. Available in 6-point opened-end and 6-point closed-end designs. Both compatible with all of our nutted drive assemblies.

WR - 8101 - A Open-end Wrench
WR - 8101 - B Closed-end Wrench

Power Steering Pulley Removal and Installation Kits

PSR-7005-A Power Steering Pulley Removal and Installation Kit with Carrying Case

Pulley Remover 5/8 x 15 UNF



Pulley Removing Collet



5/8 x 15 UNF (GM)



Pulley Installer 3/8 x 16 UNC



Pulley Spacer



3/8 x 16 UNC (GM)



PSR-7005-B Power Steering Pulley Installation Tool

Power Steering Pulley Press-On Tool

1. With the drive nut & the pulley assembled onto the forcing screw, thread the forcing screw into the pump shaft.
2. Press on the pulley to proper depth by turning the drive nut

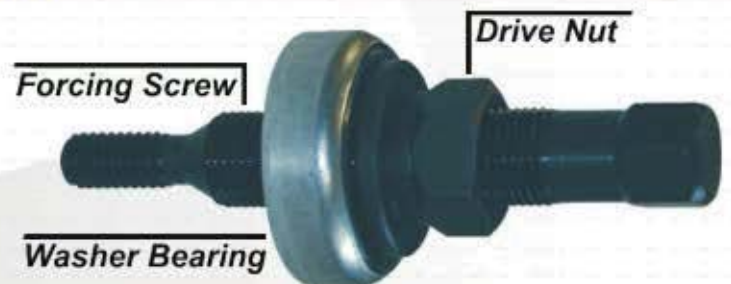

Lightweight Billet Aluminum Single and Double ended AN Wrenches

-8 Carberator Wrench



-8 Carburetor wrench. -8 end for fuel line, 1" end for the power valve and closed middle to adjust needle and seat. Made from 1/2" thick billet aluminum.

WR - 9100 - PV - 8

Optional Colors with an order of 25 sets or more



-8 AN Wrench



-8 AN wrench. -8 straight end and -8 angled end. Made from billet aluminum. -6 and larger wrenches are 1/2" thick.

WR - 9100 - 8

Optional Colors with an order of 25 sets or more



-6 Carberator Wrench



-6 Carburetor wrench. -6 end for fuel line, 1" end for the power valve and closed middle to adjust needle and seat. Made from 1/2" thick billet aluminum.

WR - 9100 - PV - 6

Optional Colors with an order of 25 sets or more



-10 AN Wrench



-10 AN wrench. -10 straight end and -10 angled end. Made from billet aluminum. -6 and larger wrenches are 1/2" thick.

WR - 9100 - 10

Optional Colors with an order of 25 sets or more



-3 AN Wrench



-3 AN wrench. -3 straight end and -3 angled end. Made from billet aluminum. -3 and -4 wrenches are 3/8" thick.

WR - 9100 - 3

Optional Colors with an order of 25 sets or more



-12 AN Wrench



-12 AN wrench. -12 straight end and -12 angled end. Made from billet aluminum. -6 and larger wrenches are 1/2" thick.

WR - 9100 - 12

Optional Colors with an order of 25 sets or more



-4 AN Wrench



-4 AN wrench. -4 straight end and -4 angled end. Made from billet aluminum. -3 and -4 wrenches are 3/8" thick.

WR - 9100 - 4

Optional Colors with an order of 25 sets or more



-16 AN Wrench



-16 AN wrench. -16 straight end and -16 angled end. Made from billet aluminum. -6 and larger wrenches are 1/2" thick.

WR - 9100 - 16

Optional Colors with an order of 25 sets or more



-6 AN Wrench



-6 AN wrench. -6 straight end and -6 angled end. Made from billet aluminum. -6 and larger wrenches are 1/2" thick.

WR - 9100 - 6

Optional Colors with an order of 25 sets or more



-20 AN Wrench



-20 AN wrench. -20 straight end and -20 angled end. Made from billet aluminum. -6 and larger wrenches are 1/2" thick.

WR - 9100 - 20

Optional Colors with an order of 25 sets or more



Single Ended AN Wrenches



Optional Colors with an order of 25 sets or more

Single ended, billet aluminum, 1/2" thick, AN Wrenches. These wrenches feature a one-ended design, allowing you to reach tight or awkward places. For added comfort a perfect fit hand grip has been added. Now available in the sizes -6 through -20.

Belt Driven Cam Drive, Runs in Oil Under Stock Cover **CDA-8001x1 1/8"**

Lightweight Billet Aluminum Cam Drive Components. Driven with one Belt, runs in oil under the stock cover, use kit number CDA-8001x1 1/8 HD if you wish to use the Heavy Duty belt, recommended for for long races or a full season

Radius Tooth Cog Cam Pulley



Lightweight billet aluminum cam pulley, fits under stock cam drive cover and runs in oil.

CP - 8001 - A
CP - 8001 - B .010 over

End bearing and thrust bearing kit. Supplied with 3 allen bolts, the bearing for the pulley, and the end bearing.

CB - 8001 - A (End Bearing)
CB - 8001 - B (Bearing)
CB - 8001 - C (Bolts)



Cam Pulley Bearings →

Cam Drive Crank Pulleys



Lightweight billet aluminum Cam Drive Crank Pulley. Available for both small block Chevy, and big block Chevy crank snouts. Uses standard threaded holes for easy removal.

CS - 8001 - A (SB Crank Snout)
CS - 8001 - B (BB Crank Snout)

Belts



Heavy duty cog cam drive belt; designed to run in oil under stock cam drive cover. Cam drive belts are available in a regular heavy duty material, and our extra-heavy duty material. Extra-heavy duty is recommended if the same belt is going to be used for the length of the season.

CS - 8001 - 1 1/8" (Regular-Heavy duty belt)
CS - 8001 - 1 1/8" - HD (Extra-Heavy duty belt)

SB Chevy, Serpentine, Crank to WP & PS Drive **1004-S-SB-NE**

Lightweight Billet Aluminum Serpentine Water Pump & Power Steering Drive , Short Water Pump

Kit# 2051-RA (Page 36)

Lightweight design, one wire alternator kit, horsepower saving Radius Tooth Drive design, 35, 45, 65 or 120amp

Note:

When you are using a PS-9008-AL-R with kit 1004-S-SB-NE a 5PK-915 belt is suggested properly orientate the reservoir.

PS-8001-SB-DS

Lightweight billet aluminum power steering barcket, with mounting bolts & spacers.

WP-5104-C-4"

Lightweight billet aluminum, 4" O.D. water pump pulley. Different sizes and offsets are available.

PS-8009-AL (Optional)

Lightweight billet aluminum power steering pump. Also available in steel. Both models available with or without built-in reservoir.

DH-8101-NE-A 2.5"

Lightweight billet aluminum drive hub. Precision fit with I.D. boss to register to the balancer. Hub is Supplied with BEC-2109-D 5 1/2" bolt & end cap kit.

PS-5106-B-4"

Lightweight billet aluminum 4" power steering pulley. Different sizes are available. Call for the ratio that will work for you.

CS-5102-E

Lightweight billet aluminum 3 1/2" crankshaft pulley. Different sizes available.

5PK-890

35.039" long, reinforced, poly-v, 5 groove serpentine belt. Call for the belt that will best fit your application

Part Number Descriptions:

- PS = Power Steering
- CS = Crankshaft
- WP = Water Pump
- DH = Drive Hub
- 5100 = Serpenine
- 5102 = Applies to Crankshaft
- 5104 = Applies to Water Pump
- 5106 = Applies to Power Steering



PS-8009-AL-R

Lightweight aluminum power steering pump. with built-in reservoir.

PS-8009-AL

Lightweight aluminum power steering pump.



Aluminum Reservoir 'PS-8101-A'



Aluminum, modular, power steering tank with built-in fittings & universal bracket to mount to any size frame rail or the fire wall.

Power Steering Pump Press on Hub 'DH-8101-PS'

Our billet aluminum hub makes it easy to change your power steering pulley. A versatile Dual Dowel mounting configuration to accepts all 'WC' crankshaft pulleys. Supplied with 3/8" flat head bolt & end cap kit.



What sets Jones Racing Products' Belt Drives apart from the rest?

Jones Racing Products has been the originator of the racing industry's belt drives for more than 20 years. This is due to Jones' extensive background knowledge and understanding of your needs. All of our products are made lightweight, and designed to run efficiently creating horsepower. A large array of ratios are available for all of our drive components to improve overall engine efficiency and horsepower. Durability and longevity are always key factors in designing our product.

Ford, Serpentine, CS to WP & CS to PS Drive **1005-S-DHC**

Lightweight Billet Aluminum Serpentine Crankshaft to Water Pump & Power Steering 1-Belt Setup

5PK-915

36.024 inch long, reinforced poly-v, 5 groove, serpentine belt, drives the water pump & Power Steering.

WP-5104-F-4"

Lightweight, billet aluminum, 4" O.D., water pump pulley. Different sizes and offsets are available.

DH-8101-WC-F3 (or F4 4-Bolt)

Lightweight, billet aluminum, drive hub. Precision fit with I.D. boss to register to the balancer, supplied with bolts, & end cap: BEC-2109-H 1/2x4.

CS-5102-E

Lightweight, billet aluminum 3.5" Crankshaft pulley to drive Water Pump & Power Steering.

PSH-8001-MK

Billet aluminum hex spacers available for 7/16" or 3/8" head holes. Sets are sold in custom lengths unique to your engine which ensures pulley alignment.

PSH-8001-F

Lightweight, billet aluminum 1/2" thick power steering bracket for JRP PS Pump.

PS-8009-AL-R

Lightweight, Aluminum PS pumps with or without a built in 18oz tank. If using pumps with a tank use 2nd bracket PS-8001-SM.

PS-5106-B-4"

Lightweight, billet aluminum, 4 inch power steering pulley. Different sizes are available. Call for the ratio that will work for you.

PS-8009-AL-R

Lightweight aluminum power steering pump. with built-in reservoir.

PS-8009-AL

Lightweight aluminum power steering pump.

Part Number Descriptions:

- PS = Power Steering
- CS = Crankshaft
- WP = Water Pump
- DH = Drive Hub
- 5100 = Serpenine
- 5102 = Applies to Crankshaft
- 5104 = Applies to Water Pump
- 5106 = Applies to Power Steering

WP-9104-SBF-AL

Aluminum water pump



Aluminum Reservoir 'PS-8101-A'

Aluminum, modular, power steering tank with built-in fittings & universal bracket to mount to any size frame rail or the fire wall.



Power Steering Pump Press on Hub 'DH-8101-PS'

Our billet aluminum hub makes it easy to change your power steering pulley. A versatile Dual Dowel mounting configuration to accepts all 'WC' crankshaft pulleys. Supplied with 3/8" flat head bolt & end cap kit.



Chrysler, Serpentine, CS to WP & CS to PS Drive **1008-S**

Lightweight Billet Aluminum Serpentine CS to Water Pump & CS to Power Steering 2-Belt Drive

5PK-695

27.362 inch long, reinforced poly-v, 5 groove, serpentine belt, drives the water pump from the crank.

WP-5104-WC-5"

Lightweight, billet aluminum, 5" O.D., water pump pulley. Different sizes and offsets are available.

DH-8101-WC-C

Lightweight, billet aluminum, drive hub. Precision fit with I.D. boss to register to the balancer, supplied with bolts, & end cap: BEC-2109-H 1/2x4.

CS-5102-G

CS-5102-C

Lightweight, billet aluminum 4" CS pulley to drive WP & 3" CS pulley to drive PS.

PSL-8001-C

Lightweight, billet aluminum power steering bracket, comes with mounting bolts and spacers.

PS-8009-AL-R (Optional)

Lightweight, billet aluminum power steering pump. Also available in steel, both pumps available with or without built-in reservoir.

PS-5106-B-4"

Lightweight, billet aluminum, 4 inch power steering pulley. Different sizes are available. Call for the ratio that will work for you.

5PK-825

32.480 inch long, reinforced, poly-v, 5 groove, serpentine belt. Call for the belt that will best fit your application.

Part Number Descriptions:

- PS = Power Steering**
- CS = Crankshaft**
- WP = Water Pump**
- DH = Drive Hub**
- 5100 = Serpentine**
- 5102 = Applies to Crankshaft**
- 5104 = Applies to Water Pump**
- 5106 = Applies to Power Steering**

Why is a serpentine drive better than a v-belt?

At Jones Racing Products we know how hard you strive to get every horsepower. This is why we create our drives with efficiency being our top priority. All of our components are made as light as possible. This reduces the moment of inertia, (the force required to set an object in motion). When comparing a V-belt drive & serpentine drive, keep in mind the inertia of an object is greatly reduced as your diameter is reduced. This saves horsepower. You will be saving power due to the reduced amount of frictional resistance as well. A serpentine drive requires only half the tension of a v-belt drive. This will increase your pulley & belt life 3 to 1 over v-belt, while reducing the extra strain on the main bearings, water pump, power steering pump or any other accessories you might be running. A serpentine drive is less expensive due to the reduced amount of material and time to produce it. But why stop here? Ask us about our Radius Tooth HTD or read about it on page 30.



PS-8009-AL-R

Lightweight aluminum power steering pump. with built-in reservoir.

PS-8009-AL

Lightweight aluminum power steering pump.



Aluminum Reservoir 'PS-8101-A'



Aluminum, modular, power steering tank with built-in fittings & universal bracket to mount to any size frame rail or the fire wall.

Power Steering Pump Press on Hub 'DH-8101-PS'

Our billet aluminum hub makes it easy to change your power steering pulley. A versatile Dual Dowel mounting configuration to accepts all 'WC' crankshaft pulleys. Supplied with 3/8" flat head bolt & end cap kit.



SB Chevy, Serpentine WP & PS, and Cog Alt. Drive **1014-CMP**

Lightweight billet alum. 1/2" thick engine plate for *CRATE ENGINES*. All components pulleys, belts, brackets and mounting accessories are included. Pre-assembled for easy installation

WP-9104-SBC-AL"

High performance aluminum water pump. Also available in steel.

WP-5104-WC-5.0"

Billet aluminum, Serpentine water pump pulley. Different sizes are available.

2041-RA

35, 45, 65, or 80 Amp, 1-wire, switchless, radius tooth HTD alternator drive kit. Complete with alt., brackets, pulleys, belt & mounting accessories.

DH-8101-C-DP & EC-6111-WC

SB Chevy Drive Assembly, featuring a dual dowel configuration, provided with an end cap.

MP-8101-SBC

Billet aluminum 1/2" thick, one piece, SB Chevy engine plate w/ built-in PS bracket and alt. bracket support.

PS-8009-AL-R

Lightweight, aluminum power steering pump. Also available in steel, both pumps available with or without a built-in 18oz reservoir.

PS-5106-B-5"

Lightweight, billet aluminum, 5 inch power steering pulley. Different sizes are available. Call for the ratio that will work for you.

5PK-890

30.039" Long reinforced five groove serpentine PS & WP drive belt.

CS-5102-WC-H

Lightweight, billet aluminum, 4.25", dual dowel, crankshaft pulley. Different sizes are available. Call for the ratio that will work for you.



AL-9101-A-NS

35 amp, lightweight, one-wire switchless alternator

AL-9101-B-NS

45 amp, lightweight, one-wire switchless alternator



AL-9101-C-NS

65 amp, lightweight, one-wire switchless alternator

AL-9101-E-NS

80 amp, lightweight, one-wire switchless alternator



AL-9101-D-NS

120 amp, lightweight, one-wire switchless alternator



PS-8009-AL-R

Lightweight aluminum power steering pump. with built-in reservoir.

PS-8009-AL

Lightweight aluminum power steering pump.



Aluminum Reservoir 'PS-8101-A'



Aluminum, modular, power steering tank with built-in fittings & universal bracket to mount to any size frame rail or the fire wall.

Power Steering Pump Press on Hub 'DH-8101-PS'

Our billet aluminum hub makes it easy to change your power steering pulley. A versatile Dual Dowel mounting configuration to accept all 'WC' crankshaft pulleys. Supplied with 3/8" flat head bolt & end cap kit.



SB Ford, Serpentine WP & PS, and Cog Alt. Drive **1015-FMP**

Lightweight billet alum. 1/2" thick engine plate for *CRATE ENGINES*. All components pulleys, belts, brackets and mounting accessories are included. Pre-assembled for easy installation

WP-9104-SBC-AL*

High performance aluminum water pump. Also available in steel.

WP-5104-WC-4.5"

Billet aluminum, Serpentine water pump pulley. Different sizes are available.

MP-8101-SBF

Billet aluminum 1/2" thick, one piece, SB Ford engine plate w/ built-in PS bracket and alt. bracket support.

PS-8009-AL-R

Lightweight, aluminum power steering pump. Also available in steel, both pumps available with or without a built-in 18oz reservoir.

PS-5106-B-4.5"

Lightweight, billet aluminum, 4.5 inch power steering pulley. Different sizes are available. Call for the ratio that will work for you.

5PK-940

37.008" Long reinforced five groove serpentine PS & WP drive belt.

CS-5102-H

Lightweight, billet aluminum, 4.25", 1 1/8 Bore, crankshaft pulley. Different sizes are available. Call for the ratio that will work for you.

2065-RA

35, 45, 65, or 80 Amp, 1-wire, switchless, radius tooth HTD alternator drive kit. Complete with alt., brackets, pulleys, belt & mounting accessories.

DH-8101-WC-F3 & SP-6103-K

Lightweight, billet aluminum Ford Drive Hub and spacer Kit. Available in a 3 or 4 bolt design.

AL-9101-A-NS

35 amp, lightweight, one-wire switchless alternator



AL-9101-B-NS

45 amp, lightweight, one-wire switchless alternator



AL-9101-C-NS

65 amp, lightweight, one-wire switchless alternator



AL-9101-E-NS

80 amp, lightweight, one-wire switchless alternator



AL-9101-D-NS

120 amp, lightweight, one-wire switchless alternator



PS-8009-AL-R

Lightweight aluminum power steering pump. with built-in reservoir.



PS-8009-AL

Lightweight aluminum power steering pump.



Aluminum Reservoir 'PS-8101-A'

Aluminum, modular, power steering tank with built-in fittings & universal bracket to mount to any size frame rail or the fire wall.



Power Steering Pump Press on Hub 'DH-8101-PS'

Our billet aluminum hub makes it easy to change your power steering pulley. A versatile Dual Dowel mounting configuration to accepts all 'WC' crankshaft pulleys. Supplied with 3/8" flat head bolt & end cap kit.



Chrysler, Serpentine WP & PS, and Cog Alt. Drive **1018-RMP**

Lightweight billet alum. 1/2" thick engine plate for *CRATE ENGINES*. All components pulleys, belts, brackets and mounting accessories are included. Pre-assembled for easy installation

WP-9104-SBC-AL"

High performance aluminum water pump. Also available in steel.

WP-5104-WC-5.0"

Billet aluminum, Serpentine water pump pulley. Different sizes are available.

2064-RA

35, 45, 65, or 80 Amp, 1-wire, switchless, radius tooth HTD alternator drive kit. Complete with alt., brackets, pulleys, belt & mounting accessories.

DH-8101-WC-C & EC-6111-B

Chrysler Drive Assembly, w/ end cap and spacer kit. 1 1/8" mandrel with built in balancer register.

MP-8101-CR

Billet aluminum 1/2" thick, one piece, Chrysler engine plate w/ built-in PS bracket and alt. bracket support.

PS-8009-AL-R

Lightweight, aluminum power steering pump. Also available in steel, both pumps available with or without a built-in 18oz reservoir.

PS-5106-B-5"

Lightweight, billet aluminum, 5 inch power steering pulley. Different sizes are available. Call for the ratio that will work for you.

5PK-940

37.008" Long reinforced five groove serpentine PS & WP drive belt.

CS-5102-G

Lightweight, billet aluminum, 4" x 1 1/8" Bore, crankshaft pulley. Different sizes are available. Call for the ratio that will work for you.



AL-9101-A-NS

35 amp, lightweight, one-wire switchless alternator

AL-9101-B-NS

45 amp, lightweight, one-wire switchless alternator



AL-9101-C-NS

65 amp, lightweight, one-wire switchless alternator

AL-9101-E-NS

80 amp, lightweight, one-wire switchless alternator



AL-9101-D-NS

120 amp, lightweight, one-wire switchless alternator



PS-8009-AL-R

Lightweight aluminum power steering pump. with built-in reservoir.

PS-8009-AL

Lightweight aluminum power steering pump.



Aluminum Reservoir 'PS-8101-A'



Aluminum, modular, power steering tank with built-in fittings & universal bracket to mount to any size frame rail or the fire wall.

Power Steering Pump Press on Hub 'DH-8101-PS'

Our billet aluminum hub makes it easy to change your power steering pulley. A versatile Dual Dowel mounting configuration to accepts all 'WC' crankshaft pulleys. Supplied with 3/8" flat head bolt & end cap kit.



SB Chevy Serp. WP Drive 1025-S

Available for SB Chevy (shown), SB Ford, BB Chevy & Chrysler
see similar **SBC kit 1024-S** on page 55

WP-9104-A

Aluminum, .0625 (1/16") shims to properly and easily align the WP pulley with the CS pulley. Supplied in a set of 3.

WP-5104-WC- 5" *

Lightweight billet aluminum, 5" O.D. water pump pulley. Different sizes are available to provide you with the ratio you need.

DH-8101-WC-DE

Ford billet aluminum one piece drive hub. Kit is supplied with mounting bolt and end cap kit BEC-2109-H.

5PK-695

27.165" long, reinforced 5 groove, serpentine belt.

CS-5102-F *

Lightweight billet aluminum serpentine crankshaft pulley. Different sizes available.

CSN-6103-A

Billet aluminum crankshaft nut to turn over the engine. Best if used with WR-8101-B closed-end billet wrench.

*Many ratios available to adapt to your needs!
see page 55 for more options

SB Ford Serp. WP Drive 1026-S

Available for SB Ford (shown), SB Chevy, BB Chevy & Chrysler

WP-9104-A

Aluminum, .0625 (1/16") shims to properly and easily align the WP pulley with the CS pulley. Supplied in a set of 3.

WP-5104-WC- 5" *

Lightweight billet aluminum, 5" O.D. water pump pulley. Different sizes are available to provide you with the ratio you need.

DH-8101-WC-DE

Ford billet aluminum one piece drive hub. Kit is supplied with mounting bolt and end cap kit BEC-2109-H.

5PK-695

27.165" long, reinforced 5 groove, serpentine belt.

CS-5102-G

Lightweight billet aluminum serpentine 4" crankshaft pulley. Diff. sizes available.

CSN-6103-A

Billet aluminum crankshaft nut to turn over the engine. Best if used with WR-8101-B closed-end billet wrench.

When using a CS-5102-F 3.75" Pulley use a 5PK-690

SB Chevy, CS to WP & AL, and CS to PS Serpentine Drive **1049-S**

Street Smart Serpentine WP, Alternator, & Power Steering Drive Available for SB Chevy (Shown), Chrysler & Ford

Kit# 2051

65 amp one wire alternator, switchless model. 35, 45 80 & 120 amp models also available.

AL-5105-A 2.5"

Lightweight billet aluminum, 2.5" O.D. serpentine alternator pulley.

5PK-1040

5PK-890

40.954" and 35.039" long, reinforced, poly-v, 5 groove serpentine belts.

CS-5102-L-5.875

CS-5102-H-WC

Lightweight billet aluminum 5 7/8" (L) & 4" (H-WC) crank shaft pulleys with built in 3-bolt hub.

EC-6111-N 7/16

Billet aluminum end cap, with a machined in nut to turn over the engine and add a eye catching custom look. 7/16" Bolt kit included.

WP-5104-WC-5"

Lightweight billet aluminum, 5" O.D. water pump pulley. Different sizes and offsets are available.

PS-8001-SB-DS

Lightweight, billet aluminum power steering mount with mounting bolts and spacers.

PS-8009-AL-R

Lightweight billet aluminum power steering pump, with built in reservoir tank. Also available in steel, both models available with or without built-in reservoir.

PS-5106-B-4"

Lightweight billet aluminum, 4 inch power steering pulley. Different sizes are available. Call for the ratio that will work for you.

DH-3102-A

Lightweight billet aluminum, drive hub. Mounts pulleys to your stock or aftermarket SBC balancer.



AL-9101-A-NS

35 amp, lightweight, one-wire switchless alternator

AL-9101-B-NS

45 amp, lightweight, one-wire switchless alternator



AL-9101-C-NS

65 amp, lightweight, one-wire switchless alternator

AL-9101-E-NS

80 amp, lightweight, one-wire switchless alternator



AL-9101-D-NS

120 amp, lightweight, one-wire switchless alternator



PS-8009-AL-R

Lightweight aluminum power steering pump. with built-in reservoir.

PS-8009-AL

Lightweight aluminum power steering pump.



Power Steering Fluid 'QT-8009'

High Performance Anti Fomaing Power Steering Fluid. Designed to reduce heat in you system.

Power Steering Pump Press on Hub 'DH-8101-PS'

Our billet aluminum hub makes it easy to change your power steering pulley. A versatile Dual Dowel mounting configuration to accepts all 'WC' crankshaft pulleys. Supplied with 3/8" flat head bolt & end cap kit.



SB Chevy Radius Tooth HTD Fuel Pump Drive kit # 2001-RA

Billet Aluminum Cog Combination Fuel and PS, Front-end Drive available for SBC, Ford and Chrysler

KSE-8009-C

Fuel and Power Steering combination tandem pump. Its unique design saves horsepower and provides a better overall efficiency while delivering a smooth uniform flow.

OP-6103-32

Lightweight billet aluminum pulley, radius tooth HTD design, 32 tooth, .625 bore, 1 1/4" wide, uses 3/16" key and 5 set screws to mount.

BG-9108-W-32

Belt guide for water pump drive pulley

FP-9100-C

Lightweight billet aluminum fuel pump bracket. Mounts from water pump. Bolts and spacers provided.

WP-9104-28

Lightweight billet aluminum .825" wide, Radius Tooth HTD fuel pump drive pulley. Drives fuel pump off of water pump.

720-20

Reinforced radius tooth HTD belt. Call for the belt that will best fit your application.

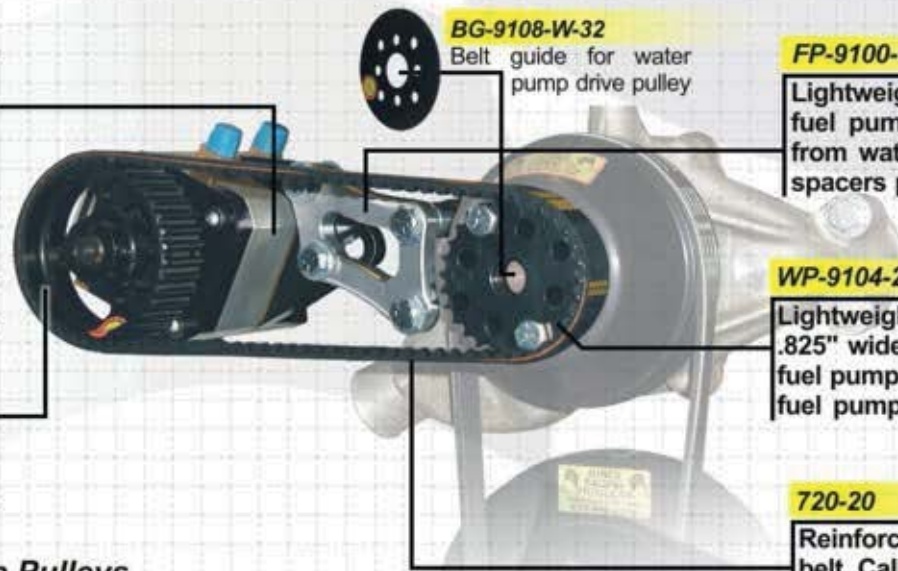

1 1/4" Wide Fuel Pump Pulleys

- OP - 6103 - 28
- OP - 6103 - 30
- OP - 6103 - 32
- OP - 6103 - 33
- OP - 6103 - 34
- OP - 6103 - 35
- OP - 6103 - 36
- OP - 6103 - 37
- OP - 6103 - 38
- OP - 6103 - 40
- OP - 6103 - 44
- OP - 6103 - 45
- OP - 6103 - 46
- OP - 6103 - 47
- OP - 6103 - 48



Tandem Power Steering & Fuel Pump

KSE-8009-C Pulley and belt guides sold separately



Chevy

- FP - 9100 - B (Short Mount, 8.25-8.75" C_t)
- FP - 9100 - C (Regular Mount 8.75-9.4375" C_t)



.825" Wide Drive Pulley
WP-9104-28



Ford

FP-9100-A



Belt Guides for Oil and Fuel Pumps

- BG - 6108 - 35
- BG - 6108 - 36
- BG - 6108 - 40
- BG - 6108 - 42
- BG - 6108 - 44
- BG - 6108 - 45
- BG - 6108 - 48



Chrysler

FP-9100-F



SB Chevy, Crankshaft to Oil Pump Radius Tooth HTD Drive **2002-RA**

Lightweight Billet Aluminum Radius Tooth HTD OP Drive, Available in Many Ratios w/ Accomadating Belts for center distance

DH-8101-NE 3.75"

Lightweight billet aluminum drive hub. Precision made, fits inside of Small Block Chevy balancer, mounts with Woodruff key and bolt. This hub features a built-in nut & spacer and is supplied with BEC-2019-F.

CS-6102-18-AS

Lightweight billet aluminum, radius tooth HTD design, 18 tooth, 1 1/8" bore, .825" wide crankshaft pulley.

BG-6108-A

Lightweight aluminum belt guides, BG-6108-A guides are also available for the oil pump pulley.

3 Stage Oil Pump (optional)

Billet aluminum oil pumps 3 & 4 & 5 stage pumps available. Call for complete details.

560 - 20

22.047" long reinforced radius tooth HTD belt. Call for the belt that will best fit your application.

OP-6103-32

Lightweight billet aluminum oil pump pulley, radius tooth HTD design, 32 tooth, .625 bore, 1 1/4" wide, uses 3/16" key & 5 set screws to mount.

Oil Pump Pulleys

OP - 6103 - 28
 OP - 6103 - 30
 OP - 6103 - 32
 OP - 6103 - 33
 OP - 6103 - 34
 OP - 6103 - 35
 OP - 6103 - 36
 OP - 6103 - 37
 OP - 6103 - 38
 OP - 6103 - 40
 OP - 6103 - 44
 OP - 6103 - 45
 OP - 6103 - 46
 OP - 6103 - 47
 OP - 6103 - 48

Crankshaft Pulleys

CS - 6102 - 17 - A	CS - 6102 - 29 - A
CS - 6102 - 18 - A	CS - 6102 - 30 - A
CS - 6102 - 19 - A	CS - 6102 - 31 - A
CS - 6102 - 20 - A	CS - 6102 - 32 - A
CS - 6102 - 21 - A	CS - 6102 - 33 - A
CS - 6102 - 22 - A	CS - 6102 - 34 - A
CS - 6102 - 23 - A	CS - 6102 - 35 - A
CS - 6102 - 24 - A	CS - 6102 - 36 - A
CS - 6102 - 25 - A	CS - 6102 - 37 - A
CS - 6102 - 26 - A	CS - 6102 - 38 - A
CS - 6102 - 27 - A	CS - 6102 - 39 - A
CS - 6102 - 28 - A	CS - 6102 - 40 - A

3, 4, & 5 Stage Oil Pumps

Using these pumps enables you to:

- Run zero weight oil
- Run lower oil pressure at higher volumes

Johnson HTP pumps...

- Produce high vacuum
- Runs 25% more efficient than any other pump
- Eliminate cavitation
- Come with built-in AN fitting in the pump
- Come with a one year warranty

Radius Tooth HTD Oil Pump Drive, Mounts to Bell Housing 2004-RA

Lightweight Billet Alum. Oil Pump Drive , Driven from the back of the crankshaft, Mounts to the Bell Housing

640 - 20

2 Reinforced, radius tooth HTD belts, 20 mm wide. Extra belt to keep in bell housing for added ensurance

OP-6103-38

Lightweight, billet aluminum, oil pump pulley, radius tooth HTD design, 28 tooth to 56 tooth available, .625 bore, 1 1/4" wide, uses 3/16" key and 5 set screws to mount.

RDH-6102-22

Lightweight, billet aluminum, Radius Tooth HTD design, 22 tooth drive pulley, 30mm wide with broached I.D. for transmission's spline and 6-bolt hub for chevy crank shaft bolt circle.

BG-6108-38

Removable and reusable lightweight, billet aluminum, belt guides for the oil pump pulley. Guides are available for all of our popular pulleys. see pg 23



Our HTD Radius Tooth pulley design creates a positive belt to pulley engagement therefore requiring ten times less belt tension than conventional belt drive systems, reducing friction, drag and harmonics leading to horsepower gains. All of our pulleys are CNC machined from 6061-T6 billet aluminum, then a C-72 Rockwell hard coating is applied, ensuring a reliable, prolonged life.

Lightweight billet aluminum, Radius Tooth HTD, oil pump pulleys, .625" I.D.

Each pulley has a 5/8" I.D. and mounts with a 3/16" key and five set screws. Our Radius Tooth HTD design requires only 6 pounds of tension using either our 20mm wide or 30mm wide belt, thus saving valuable horsepower while reducing ware on your components. 1.25" wide oil pump pulleys feature a 1/4" radiused front making it easier to slide the belt on and off the pulley to prime your oil system.

- | | |
|---------------------|---------------------|
| OP-6103- 40 -1 1/4" | OP-6103- 45 -1 1/4" |
| OP-6103- 40 -1" | OP-6103- 46 -1 1/4" |
| OP-6103- 42 -1" | OP-6103- 47 -1 1/4" |
| OP-6103- 44 -1" | OP-6103- 48 -1" |

Belt Guides are also available, shown on page 24

What benefits does a Radius Tooth drive have over a Serpentine drive?

Less resistance means more power! Whether it is friction or inertia you're fighting to gain horsepower, our Radius Tooth design beats v-belt, serpentine, and Gilmer hands down! Required tension on a Radius Tooth drive kit is one-tenth that of a serpentine, and one-half that of a Gilmer design. When a belt requires more tension the frictional resistance is amplified causing one of the most dreaded side effects, excessive utilization of power. Our radius tooth design requires only 6 pounds of tension; this eliminates undue horsepower loss, while greatly reducing wear on the pulleys & belts. Constant resistance is no longer a problem for the main bearings, along with the water pump and other accessories when using a Radius Tooth design. A radius tooth design will not only reduce wear on your drive components but it will also outlive a serpentine design 3 to 1. So far we have a horsepower saving, friction reducing, life increasing design, yet there are more advantages. Weight is always a key factor when designing a high performance part. This is why all of our parts are as light as possible, and since the Radius Tooth design doesn't require the belt wrap of a v-belt or serpentine design, the pulleys can be smaller, thus significantly reducing weight and exponentially reducing inertia, which consists of the resistance an object, the pulley in our case, produces when put into motion.

DH-8101-NE-A 2.5"

Lightweight billet aluminum drive hub. Precision fit with I.D. boss to register to the balancer supplied with bolt & end cap BEC-2109-E

600 - 20

23.622" Long reinforced radius tooth HTD belt. Call for the belt that will best fit your application

CS-6102-25-AS

Lightweight billet aluminum, radius tooth HTD design, 25 tooth, 1 1/8" bore, .825" wide crank pulley.

3 - BG-6108-A

Lightweight aluminum belt guides. Belt guides are also available for the water pump pulley.

DH-8101-NE-A 2.5"

Lightweight billet aluminum drive hub. Precision fit with I.D. boss to register to the balancer supplied with bolt & end cap kit BEC-2109-F

Cog WP Drive Kit 2010-RA

Available for SB Chevy (Shown), BB Chevy, Ford & Chrysler

WP-6104-35

Lightweight billet aluminum, Radius Tooth HTD water pump pulley. Different sizes are available to provide you with the ratio you need

600 - 20

23.622" Long reinforced radius tooth HTD belt. Call for the belt that will best fit your application

CS-6102-25-AS

Lightweight billet aluminum, radius tooth HTD design, 18 tooth, 1 1/8" bore, .825" wide crank pulley

BG-6108-A

Lightweight aluminum belt guides, Belt guides are also available for the water pump pulley.

Cog WP & OP Drive Kit 2015-RA

Available for Small Block Chevy (Shown), BB Chevy, Ford & Chrysler

WP-6104-35

Lightweight billet aluminum, Radius Tooth HTD water pump pulley. Different sizes are available to provide you with the ratio you need
see page 22

CS-6102-18-AS

Lightweight billet aluminum, radius tooth HTD design, 18 tooth, 1 1/8" bore, .825" wide crank pulley.

560 - 20

22.047" long reinforced radius tooth HTD belt. Call for the belt that will best fit your application.

Oil Pump (Optional)

Lightweight billet aluminum oil pump. 3, 4, and 5 stage pumps are available. Call for complete details.

OP-6104-32 1 1/4"

Lightweight billet aluminum, radius tooth HTD design, 32 tooth, .625" bore, 1 1/4" wide oil pump pulley.

BB Chevy 1-Wire, Switchless Alternator Kit 2030

Big Block Chevy, Short Water Pump, Billet Aluminum, **V-Belt** Alternator Drive.

WP-3104-A-3.5"

Lightweight billet aluminum alternator drive pulley, V-Belt design, 3.500" Diameter, fits all major water pump bolt patterns.

AL-3105-A-B-2.500"

Lightweight billet aluminum V-belt design, 2.5" diameter, .590" bore alternator pulley.

AL-9100-CL-BM

Lightweight billet aluminum support arm for alternator Bracket. Ensures a rigid backing to prevent the alt. from flexing under pressure.

2750-375

27.50" x .375 wide V-belt.

AL-9101-B-NS

45 amp. 1-wire, switchless Alternator. Features internal fan. 5.8lb. lightweight setup. 35, 65, & 80 amp models are also available for this kit

AL-9100-CL-B-BB

Billet Aluminum Alternator mount. Mounts from BBC water pump, accepts 35 & 45 amp alternators. 65 & 80 amp bracket also available.

AL-9100-CL-BK-BB

AL-9100-CL-B & BM Bolt Kit with spacers.

High Amperage Switch 'SW - 9100 - A'

High amperage switch to protect the alt when charging the system.

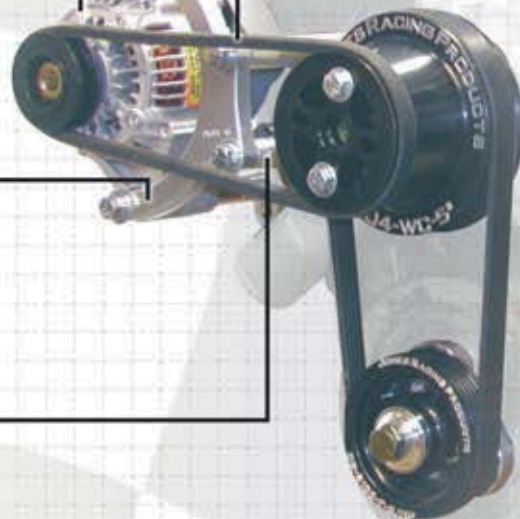

BB Chevy 1-Wire, Switchless Cog Alternator Kit 2031-RA

Big Block Chevy, Short Water Pump, Billet Aluminum, *Radius Tooth HTD*, Alternator Drive

WP-9104-32

Lightweight billet aluminum Radius Tooth HTD 32 tooth alternator drive pulley. Fits all major water pump bolt patterns.

AL-9105-24-A

Lightweight billet aluminum Radius Tooth HTD 24 tooth alternator pulley, .590" bore

AL-9100-CL-BM

Lightweight billet aluminum Support Arm for alternator bracket. Ensures a rigid backing to prevent the alt. from flexing under pressure.

680-10

26.772" Long, 10mm wide Radius Tooth HTD alt. Belt.

AL-9101-B-NS

45 amp. 1-wire, switchless Alternator. Features internal fan. 5.8lb. lightweight setup. 35, 65, & 80 amp models are also available for this kit

AL-9100-CL-B-BB

Billet Aluminum Alternator mount. Mounts from BBC water pump, accepts 35 & 45 amp alternators. 65 & 80 amp bracket also available.

AL-9100-CL-BK-BB

AL-9100-CL-B & BM Bolt Kit with spacers.

BG-9108-W

Belt guide for 32 tooth alternator drive pulley.

BBC Alternator Mounting kit:

- 1 - Top 3/8" WP Bolt, 6" Long
1-Flat & 1-Lock Washer
1-.375, 1-.900" & 1-2.300" Spacers
- 1 - Lower 3/8" WP Bolt, 6" Long
1-Flat & 1-Lock Washer
1-.750" & 1-1" Spacers
- 1 - Lower Alt. 3/8" Bolt Bolt, 6.5" Long
1-Flat & 1-Lock Washer
1-.375", 1-.900", 1-1" Spacers & 1-.375" Lock Nut & 2 Flat Washers
- 1 - Upper 8x30mm Alternator Bolt
1-Flat & 1-Lock Washer
- 1- 3/8" Flat Head Support Bracket Bolt, 1" Long

High Amperage Switch 'SW - 9100 - A'

High amperage switch to protect the alt when charging the system.



SB Chevy 1-Wire, Switchless Alternator Kit 2040

Small Block Chevy, Short Water Pump, Billet Aluminum, **V-Belt** Alternator Drive.

WP-3104-A-3.5"

Lightweight billet aluminum alternator drive pulley, V-Belt design, 3.500" Diameter, fits all major water pump bolt patterns.

AL-3105-A-B-2.500"

Lightweight billet aluminum V-belt design, 2.5" diameter, .590" bore alternator pulley.

AL-9100-CL-BM

Lightweight billet aluminum support arm for alternator Bracket. Ensures a rigid backing to prevent the alt. from flexing under pressure.

2700-375

27.00" x .375 wide V-belt.

AL-9101-B-NS

45 amp. 1-wire, switchless Alternator. Features internal fan. 5.8lb. lightweight setup. 35, 65, & 80 amp models are also available for this kit

AL-9100-CL-B

Billet Aluminum Alternator mount. Mounts from SBC water pump, accepts 35 & 45 amp alternators. 65 & 80 amp bracket also available.

AL-9100-CL-BK

AL-9100-CL-B & BM Bolt Kit with spacers.

High Amperage Switch 'SW - 9100 - A'

High amperage switch to protect the alt when charging the system.

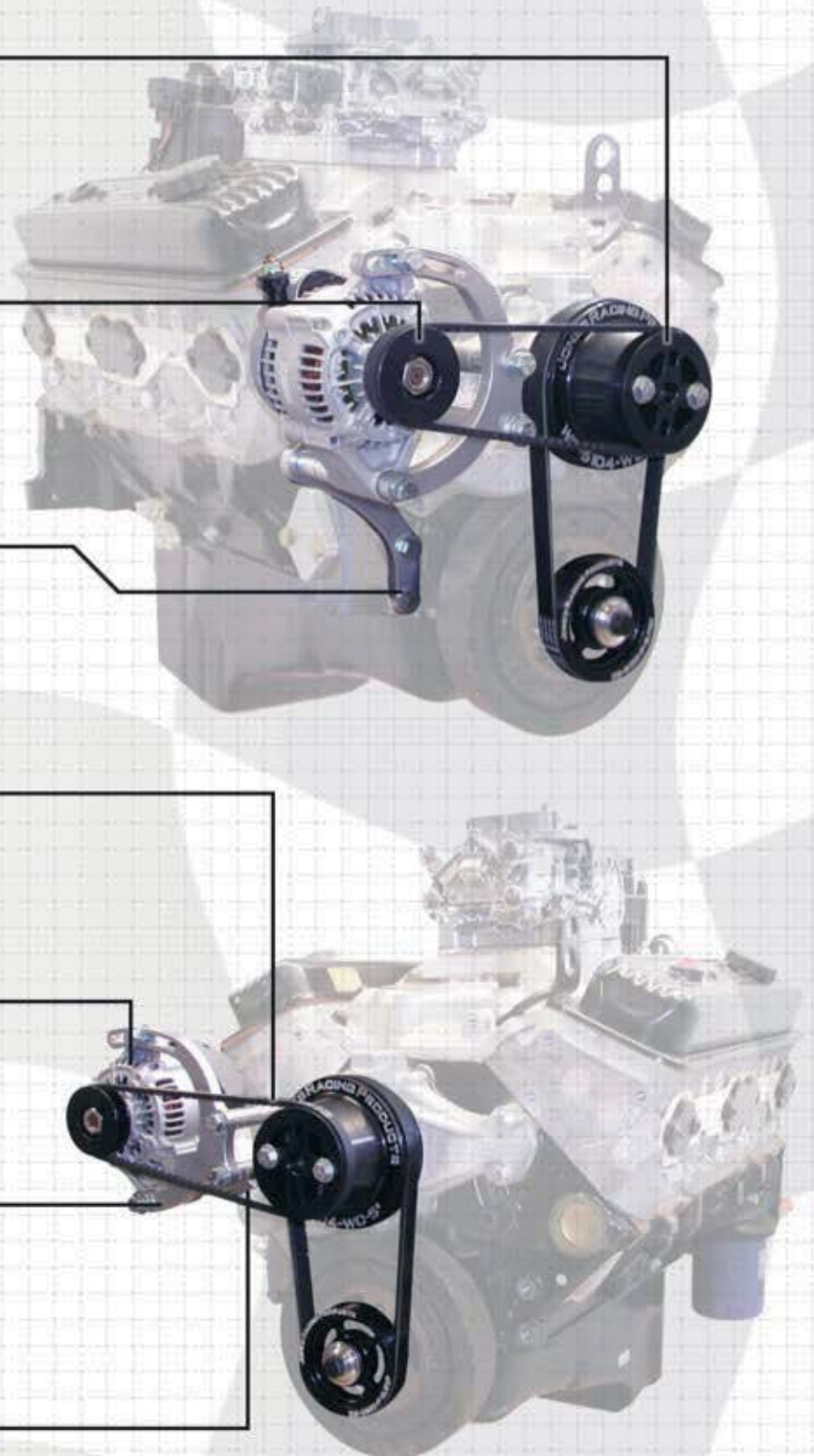

SB Chevy 1-Wire, Switchless Cog Alternator Kit 2041-RA

Small Block Chevy, Short Water Pump, Billet Alum., *Radius Tooth HTD*, Alternator Drive

WP-9104-32

Lightweight billet aluminum Radius Tooth HTD 32 tooth alternator drive pulley. Fits all major water pump bolt patterns.

AL-9105-24-A

Lightweight billet aluminum Radius Tooth HTD 24 tooth alternator pulley, .590" bore

AL-9100-CL-BM

Lightweight billet aluminum Support Arm for alternator bracket. Ensures a rigid backing to prevent the alt. from flexing under pressure.

SBC Alt. bracket mounting kit:

1- Top 3/8" WP Bolt, 6" long
1-.250", 1-2.300" & 1-.900" spacers

1- Lower 3/8" WP Bolt, 6" Long
1-.250" & 1-2.300" spacers

1- Lower 3/8" Alternator Bolt 5.5"
2 -.900" spacer

1- Upper 8×30mm Alternator Bolt
2- Block Mount 3/8" Bolts, 1" Long

680-10

26.772" Long, 10mm wide
Radius Tooth HTD alt. Belt.

AL-9101-B-NS

45 amp. 1-wire, switchless Alternator. Features internal fan. 5.8lb. lightweight setup. 35, 65, & 80 amp models are also available for this kit

AL-9100-CL-B

Billet Aluminum Alternator mount. Mounts from SBC water pump, accepts 35 & 45 amp alternators. 65 & 80 amp bracket also available.

AL-9100-CL-B-BK

AL-9100-CL-B & BM Bolt Kit with spacers.

BG-9108-W

Belt guide for 32 tooth alternator drive pulley.

High Amperage Switch 'SW - 9100 - A'

High amperage switch to protect the alt when charging the system.



Cog AL Drive Kit 2043-RA

Available for Big & Small Block Chevy; JRP or GM Alternators

AL-9105-24

Lightweight billet aluminum radius tooth HTD design, 24 tooth, .590" bore alternator pulley. Supplied with belt guides.

ADR-9100-3.5"

Billet aluminum, adjusting rod. Allows adjustment for alternator, connects from the alternator to the upper water pump bolt.

AL-9101-C-NS

65 amp. 1-wire alternator. 45 amp. mini model also available, weighing a mere 5.8 pounds.

EMP-9100-A

Lightweight, billet aluminum alternator bracket, converts MP-9101-C to bolt to a SB or BBC by the crank case.

High Amperage Switch 'SW - 9100 - A'

High amperage switch to protect the alt when charging the system.

800-10 belt

31.496" long, reinforced, radius tooth HTD belt. Call for the belt that will best fit your application.

CS-6102-36-AC

Lightweight billet aluminum alternator drive pulley, radius tooth HTD design, 20 tooth, 1/2" wide, and uses a 10mm belt, fits our 1.125" mandrels, with 1/8" key.

2 - BG-6108-E

Lightweight, aluminum belt guides, 4.5" O.D., 2 guides are included with this kit. Guide diameter depends on CS pulley tooth count.

MP-9101-C

Billet aluminum, 3/4" thick, alternator bracket. Bolts to EMP-9100-A or directly to your motor plate.

Cog AL Drive Kit 2044-RA

Available for Big & Small Block Chevy; JRP or GM Alternators

AL-9105-24

Lightweight billet aluminum radius tooth HTD design, 24 tooth, .590" bore alternator pulley. Supplied with belt guides.

ADR-9100-3.5"

Billet aluminum, adjusting rod. allows adjustment for alternator, connects from the alternator to the upper water pump bolt.

AL-9101-C-NS

65 amp. 1-wire alternator. 45 amp. mini model also available weighing a mere 5.8 pounds.

EMP-9100-A

Lightweight, billet aluminum alternator brackets, converts MP-9101-A to bolt to either a SB or BBC by the crank-case.

WP-6104-C

Billet aluminum shaft extension for use with WP-9104-32. This bushing registers your mechanical fan to the water pump shaft.

640-10 or 656-10 belt

25.197" or 25.827" long reinforced radius tooth HTD belt. Call for the belt that will best fit your application.

WP-9104-32

Lightweight billet aluminum alternator drive pulley, radius tooth HTD design, 32 tooth, fits all major water pump bolt patterns.

MP-9101-C

Billet aluminum, 3/4" thick, alt. bracket. Bolts to motor plate or to EMP-9100-A.

BG-9108-W-32

BG-9108-W-32 belt guide for alternator drive pulley.

High Amperage Switch 'SW - 9100 - A'

High amperage switch to protect the alt when charging the system.



Cog AL Drive Kit 2050-RA

Available for SB Chevy, Compatible w/ JRP or GM alternators

AL-9101-C-NS

65 amp. one-wire alternator. 45 amp. mini model also available weighing a mere 5.8 pounds.

AL-9105-24

Lightweight billet aluminum radius tooth HTD design, 24 tooth, .590" bore alternator pulley. Supplied with belt guides.

AL-9100-CL-SB

Lightweight, billet aluminum, two-piece, alternator bracket compatible with all of our alternators & GM alternators.

BG-9108-W-32

BG-9108-W-32 belt guide for alternator drive pulley.



ADR-9100-3.5"

Billet aluminum, adjusting rod. Allows adjustment for alternator. Connects from the alternator to the upper water pump bolt.

640-10 or 656-10 belt

25.197" or 25.827" long, reinforced, radius tooth HTD belt. Call for the belt that will best fit your application.

WP-9104-32

Lightweight billet aluminum alternator drive pulley, radius tooth HTD design, 32 tooth, fits all major water pump bolt patterns.

WP-6104-C

Billet aluminum shaft extension for use with WP-9104-32. This Bushing registers your mechanical fan to the water pump shaft.



High Amperage Switch 'SW - 9100 - A'

High amperage switch to protect the alt when charging the system.

Cog AL Drive Kit 2051-RA

Available for SB Chevy, Compatible w/ JRP or GM alternators

AL-9100-CL-SB-65

Lightweight billet aluminum adjusting arm for our 65 amperage alternator, Use a AL-9100-CL-45 for 45 amp. alternators.

AL-9105-24

Lightweight billet aluminum radius tooth HTD design, 24 tooth, .590" bore alternator pulley. Supplied with belt guides.

AL-9101-C-NS

65 amp. one-wire alternator. 45 amp. mini model also available weighing a mere 5.8 pounds.

AL-9100-CL-SB

Lightweight billet aluminum lower alternator bracket, two pieces. Supplied with all of the proper bolts & spacers for your applications.

640-10 or 656-10 belt

25.197" or 25.827" long, reinforced, radius tooth HTD belt. Call for the belt that will best fit your application.

WP-9104-32

Lightweight billet aluminum alternator drive pulley, radius tooth HTD design, 32 tooth fits all major water pump bolt patterns.

BG-9108-W-32

BG-9108-W-32 belt guide for alternator drive pulley.



WP-6104-C

Billet aluminum shaft extension for use with WP-9104-32. This bushing registers your mechanical fan to the water pump shaft.

High Amperage Switch 'SW - 9100 - A'

High amperage switch to protect the alt when charging the system.



Cog AL Drive Kit # 2052-RA

Available for BB & SB Chevy, Compatible w/ 35,45,65 & 80 amp alts

AL-9105-24

Lightweight billet aluminum radius tooth HTD design, 24 tooth, .590" bore alternator pulley. Belt guides included.

AL-9101-C-NS

65 amp. 1-wire alternator. 45 amp. mini model also available weighing a mere 5.8 pounds.

560-10 belt

22.047 inches long, reinforced, radius tooth HTD belt. Call for the belt that will best fit your application.

WPM-9100-C

SBC & BBC JRP alternator mount, compatible with 45 & 65 amp JRP alternators. capable of mounting on the left or right side of the water pump.

High Amperage Switch 'SW - 9100 - A'

High amperage switch to protect the alt when charging the system.

ADR-9100-6.5"

Billet aluminum, adjusting rod. Allows adjustment for alternator, connects from the alternator to the upper water pump bolt.

WP-9104-32

Lightweight, billet aluminum, alternator drive pulley, radius tooth HTD design, 32 tooth, fits all major water pump bolt patterns.

BG-9108-W-32

BG-9108-W-32 belt guide for alternator drive pulley.

WP-6104-C

Billet aluminum shaft extension for use with WP-9104-32. This Bushing registers your mechanical fan to the water pump shaft.

Cog AL Drive Kit 2053-RA

Available for SB Chevy, Compatible w/ 35, 45 & 65 JRP alts.

AL-9105-24

Lightweight, billet aluminum, radius tooth HTD design, 24 tooth, .590" bore alternator pulley, supplied with belt guides.

AL-9101-C-NS

65 amp. 1-wire alternator. 45 amp. mini model also available weighing a mere 5.8 pounds.

480-10 belt

18.898 inch long, reinforced, radius tooth HTD belt. Call for the belt that will best fit your application.

WPM-9100-A

SBC JRP alternator mount, compatible with 45 & 65 amp JRP alternators, capable of mounting to the left or right side of water pump.

High Amperage Switch 'SW - 9100 - A'

High amperage switch to protect the alt when charging the system.

ADR-9100-6"

Billet aluminum, adjusting rod. Allows adjustment for alternator, connects from the alternator to the upper water pump bolt.

WP-9104-32

Lightweight billet aluminum alternator drive pulley, radius tooth HTD design, 32 tooth, fits all major water pump bolt patterns.

BG-9108-W-32

BG-9108-W-32 belt guide for alternator drive pulley.

WP-6104-C

Billet aluminum shaft extension for use with WP-9104-32. This bushing registers your mechanical fan to the water pump shaft.

With kit 2053-RA the wp pulley must be 4.5" in diameter or less

Cog AL Drive Kit # 2054-RA

Available for BB or SB Chevy, Compatible w/ JRP or GM alternators

High Amperage Switch 'SW - 9100 - A'

High amperage switch to protect the alt when charging the system.

AL-9105-24

Lightweight, billet aluminum, radius tooth HTD design, 24 tooth, .590" bore alternator pulley, supplies with belt guides

AL-9101-C-NS

65 amp. 1-wire alternator. 45 amp. mini model also available weighing a mere 5.8 pounds.

WPM-9100-C

SBC & BBC JRP alternator mount, compatible with 45 & 65 amp JRP alternators, capable of mounting on the left or right side of water pump.

ADR-9100-8"

Billet aluminum adjusting rod. Allows easy adjustment for the alternator, connects from the alternator to the upper water pump bolt.

600-10 belt

23.622" long, reinforced, radius tooth HTD belt. Call for the belt that will best fit your application.

WP-9104-32

Lightweight, billet aluminum, alternator drive pulley, radius tooth HTD design, 32 tooth, fits all major water pump hub bolt patterns

BG-9108-W-32

BG-9108-W-32 belt guide for alternator drive pulley.

WP-6104-C

Billet aluminum shaft extension for use with WP-9104-32. This bushing registers your mechanical fan to the water pump shaft.

Cog AL Drive Kit 2055-RA

For use with a Motor Plate on a Chevy, Ford, or Chrysler.

ADJ-9100-5"

Billet aluminum, adjusting rod. Allows adjustment for alternator, connects from the alternator to the upper water pump bolt.

AL-9105-24

Lightweight, billet aluminum, radius tooth HTD design, 24 tooth, .590" bore alternator pulley, supplied with belt guides.

AL-9101-C-NS

65 amp. one-wire alternator, 45 amp. mini model also available weighing a mere 5.8 pounds.

MP-9101-C

Billet aluminum, 3/4" thick, alternator bracket. Bolts to EMP-9100-A or directly to your motor plate.

High Amperage Switch 'SW - 9100 - A'

High amperage switch to protect the alt when charging the system.

640-10 or 656-10 belt

25.197" or 25.827" long, reinforced, radius tooth HTD belt, call for the belt that will best fit your application.

WP-9104-32

Lightweight, billet aluminum, alternator drive pulley, radius tooth HTD design, 32 tooth, fits all major water pump bolt patterns.

BG-9108-W-32

BG-9108-W-32 belt guide for alternator drive pulley.

WP-6104-C

Billet aluminum shaft extension for use with WP-9104-32. This bushing registers your mechanical fan to the water pump shaft.

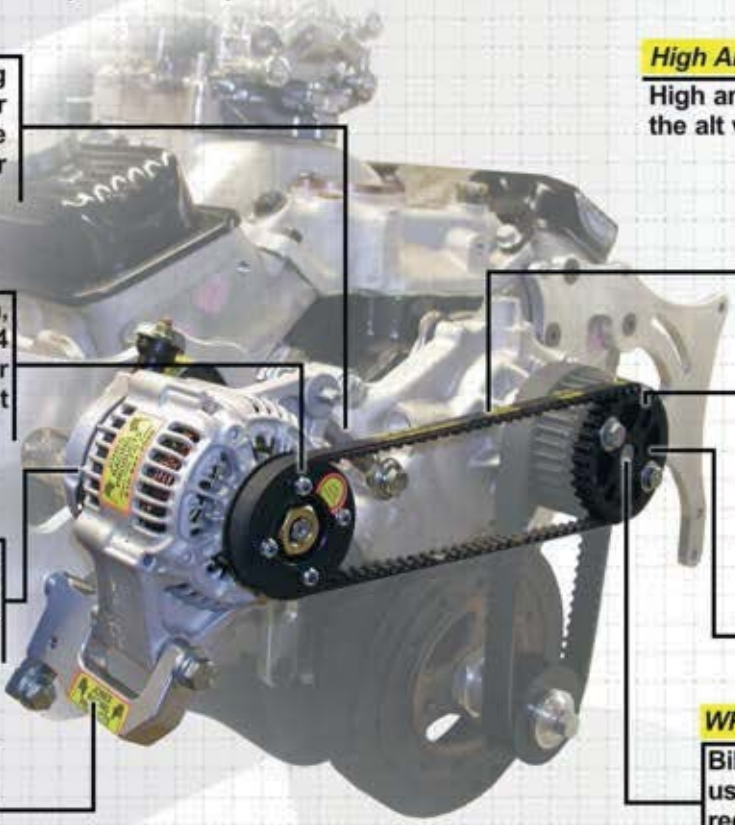
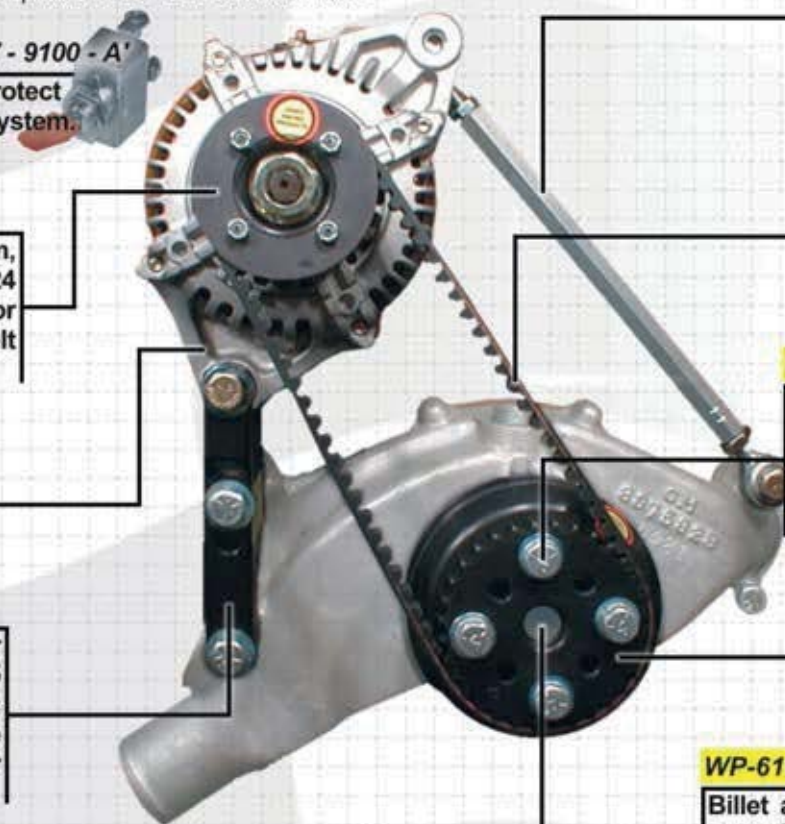

Cog AL Drive Kit 2056-RA

Available for SB Chevy, Long Water Pump w/ JRP or GM alt.

AL-9105-24

Lightweight billet aluminum radius tooth HTD design, 24 tooth, .590" bore alternator pulley, supplied with belt guides.

AL-9101-C-NS

65 amp. 1-wire alternator. 45 amp. mini model also available weighing a mere 5.8 pounds.

640-10 belt

25.196 inch long, reinforced, radius tooth HTD belt. Call for the belt that will best fit your application.

AL-9101-SB

Lightweight, billet aluminum alternator brackets for SBC, long water pump, compatible with all of JRP's alternators & most others.

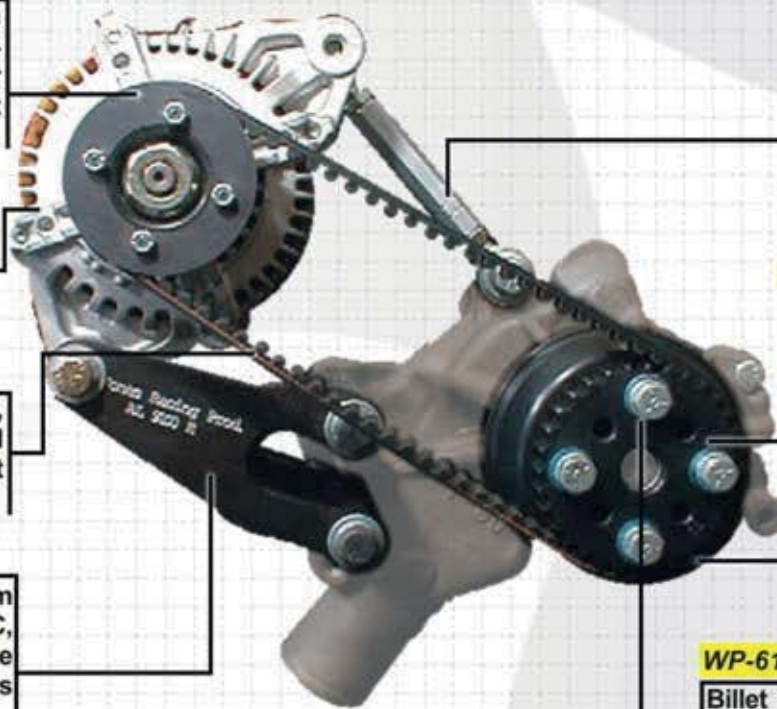

High Amperage Switch 'SW - 9100 - A'

High amperage switch to protect the alt when charging the system.



ADR-9100-3.5"

Billet aluminum, adjusting rod. allows adjustment for alternator, connects from the alternator to the upper water pump bolt.

WP-9104-32

Lightweight, billet aluminum, alternator drive pulley, radius tooth HTD design, 32 tooth, fits all major water pump hub bolt patterns.

BG-9108-W-32

BG-9108-W-32 belt guide for alternator drive pulley.



WP-6104-C

Billet aluminum shaft extension for use with WP-9104-32. This bushing registers your mechanical fan to the water pump shaft.



Cog AL Drive Kit 2057-RA

Available for Ford, Mounts to Water Pump w/ JRP alternator

AL-9105-24

Lightweight, billet aluminum, radius tooth HTD design, 24 tooth, .590" bore, alternator pulley. Supplied with belt guides.

AL-9101-C-NS

65 amp. 1-wire alternator. 45 amp. mini model also available weighing a mere 5.8 pounds.

560-10 belt

23.622 inch long, reinforced, radius tooth HTD belt. Call for the belt that will best fit your application.

AL-9101-F3

Lightweight, billet aluminum, alternator brackets for Ford's water pump. Works with all of JRP's alternators & most others.

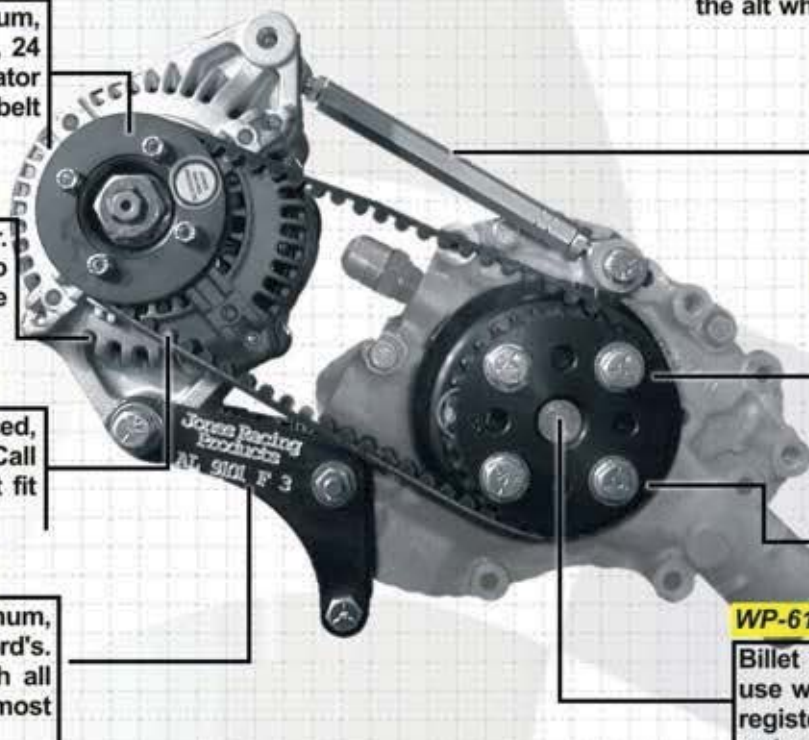

High Amperage Switch 'SW - 9100 - A'

High amperage switch to protect the alt when charging the system.



ADR-9100-5"

Billet aluminum, adjusting rod. Allows adjustment for alternator, connects from the alternator to the upper water pump bolt.

WP-9104-32

Lightweight, billet aluminum, alternator drive pulley, radius tooth HTD design, 32 tooth fits all major water pump bolt patterns.

BG-9108-W-32

BG-9108-W-32 belt guide for alternator drive pulley.



WP-6104-C

Billet aluminum shaft extension for use with WP-9104-32. This bushing registers your mechanical fan to the water pump shaft.



Cog AL Drive Kit # 2058-RA

Available for Chrysler with a 35, 45, 65 & 80 amp JRP Alternators

AL-9105-24

Lightweight, billet aluminum, radius tooth HTD design, 24 tooth, .590" bore alternator pulley. Pulley comes with belt guides.

AL-9101-C-NS

65 amp. 1-wire alternator. 45 amp. mini model also available weighing a mere 5.8 pounds.

536-10 belt

21.102 inch long, reinforced, radius tooth HTD belt. Call for the belt that will best fit your application.

CH-9100-A

Lightweight, billet aluminum, two-piece alternator bracket, compatible with our 45 & 65 amp alternators.

ADJ-9100-3.5"

Billet aluminum, adjusting rod. Allows adjustment for alternator, connects from the alternator to the upper water pump bolt.

WP-9104-32

Lightweight billet aluminum alternator drive pulley, radius tooth HTD design, 32 tooth fits all major water pump bolt patterns.

BG-9108-W-32

BG-9108-W-32 belt guide for alternator drive pulley.

WP-6104-C

Billet aluminum shaft extension for use with WP-9104-32. This bushing registers your mechanical fan to the water pump shaft.

High Amperage Switch 'SW - 9100 - A'

High amperage switch to protect the alt when charging the system.

Add-on Fuel Pump Drive Kit

Chrysler FP-9100-F

see page 13



Tandem Power Steering & Fuel Pump KSE-8009-C

Pulley and belt guides sold separately
see page 12



Belt Driven Fuel Pump FP-8009-A

Pulley and belt guides sold separately
see page 12



Ford 9" Rear AL Drive 2059-F

Mounts to Ford 9" rear, Works with JRP 65 or 80 amp alt.

BEV-27625-1/2

27 5/8" long, 1/2" wide, reinforced, 1/2" v-belt.

AL-9101-C-NS

65 amp. 1-wire alternator. Choose from the regular 65 amp or upgrade to our 80 switchless model.

AL-3105-A-E 5"

Lightweight, billet aluminum, 5.0" V-belt alternator pulley, fits all of our alternators, and works with a 1/2" v-belt.

F9-9101-A

Lightweight, billet aluminum, 3/4" thick, durable alternator bracket. Mounts alternator to Ford 9-inch rear.

Ford Yoke

Ford 9-inch rear yoke with built in v-belt pulley. Please note that we do not supply the Ford yoke.

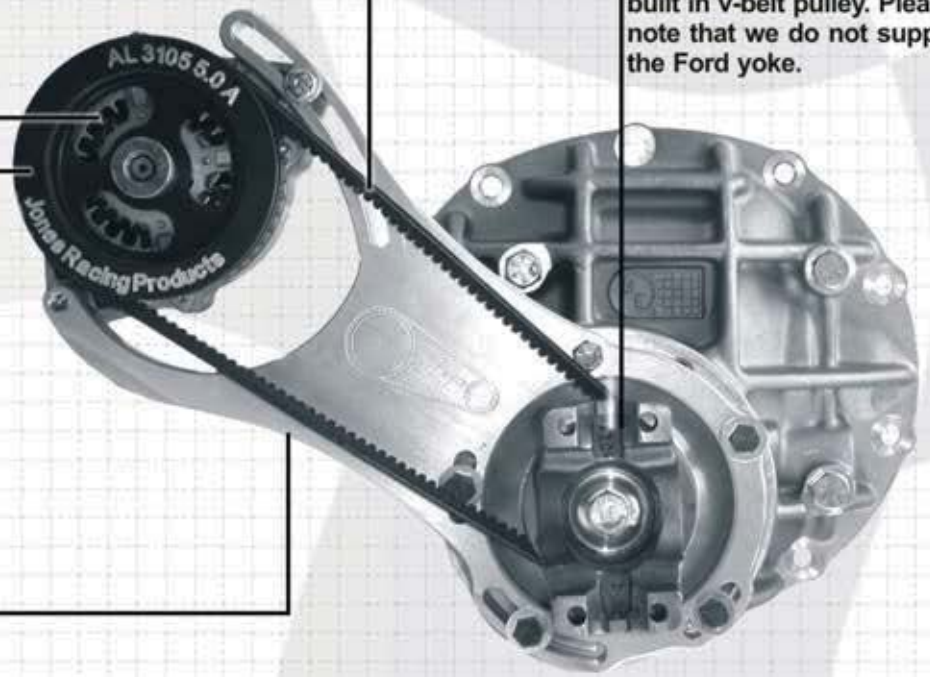

Quick Change Rear AL Drive 2059

Mounts to Quick Change rear, Works with JRP 65 or 80 amp alt.

BEV-27625-1/2

27 5/8" long 1/2" wide, reinforced, 1/2" v-belt.

AL-9101-C-NS

65 amp. 1-wire alternator. Choose from a switched or switchless model.

AL-3105-A-E 5"

Lightweight, billet aluminum, 5.0" V-belt alternator pulley, fits all of our alternators, and works with a 1/2" v-belt.

QCM-9101-A

Lightweight billet aluminum, 3/4" thick, durable alternator bracket. Mounts alternator to any quick change rear.

High Amperage Switch 'SW - 9100 - A'

High amperage switch to protect the alt when charging the system.

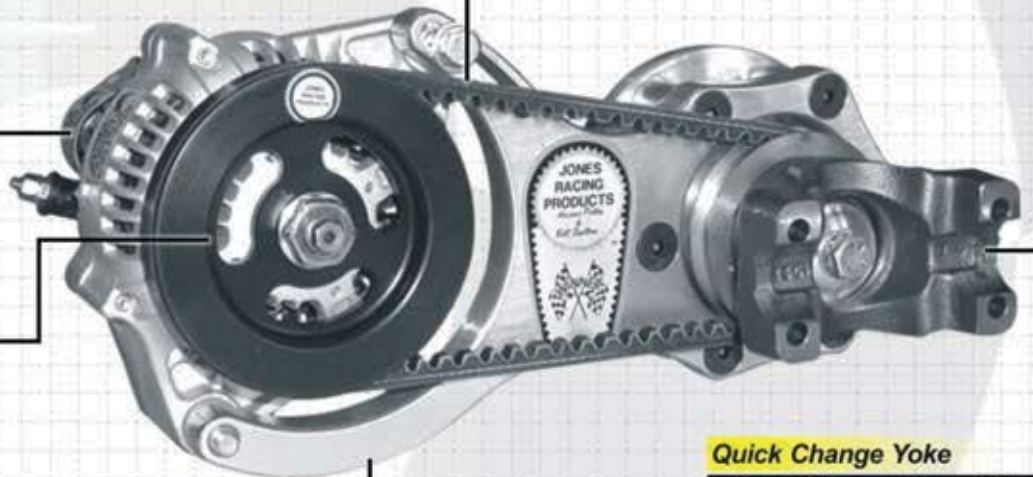

Quick Change Yoke

Quick Change Rear Yoke, with built-in v-belt drive pulley. Please note that we do not supply the Quick Change Yoke.

Cog AL Drive Kit # 2065-RA

Available for Ford 351 Windsor with a 35, 45, 65 & 80 amp JRP Alt

AL-9105-24-A

Lightweight billet aluminum Radius Tooth HTD 24 tooth alternator pulley, .590" bore

AL-9101-B-NS

45 amp. 1-wire, switchless Alternator. Features internal fan. 5.8lb. lightweight setup. 35, 65, & 80 amp models are also available for this kit

BG-9108-W

Belt Guide for the front of the WP-9104-32 Alt. Pulley

AL-9100-CL-F

Lightweight billet aluminum Alternator Mount, fits Ford, mounts from water pump. Use with 35, 45, 65, 80 amp, 1-wire switchless alt.

High Amperage Switch 'SW - 9100 - A'

High amperage switch to protect the alt when charging the system.



680-10 belt

26.772 inch long, reinforced, radius tooth HTD belt. Call for the belt that will best fit your application.

WP-9104-32

Lightweight billet aluminum Radius Tooth HTD 32 tooth alternator drive pulley. Fits all major water pump bolt patterns.

680-10

26.772" Long, 10mm wide Radius Tooth HTD alt. Belt.

AL-9100-CL-BM

Lightweight billet aluminum Support Arm for alternator bracket. Ensures a rigid backing to prevent the alt. from flexing under pressure.

Ford AL & WP Kit # 2066-RA

Ford 351W & 302 with a 35, 45, 65, 80 or 120 amp JRP Alternator Radius Tooth, HTD or Serpentine setup available.

AL-9100-RH-F

Front head-mount 1/2" thick bracket for 351W or 302.

AL-9100-RH-B

Rear head mount 1/2" thick bracket for 351W or 302.

AL-9101-E-NS

65 amp. 1-wire alternator 35 & 45 amp. mini models, 80 & 120 amp. models also available.

AL-6105-18-B & BG-6108-22

Billet Alum. radius tooth, HTD 22 tooth alternator pulley & belt guide.

ADR-9100-3.5" &

Alum. adjusting rod and Billet aluminum, 1/2" thick arm orientation bracket.

AL-9100-MK

Dual AL-9100-RH mounting & hex spacer kit assembly.

WP-9104-SBF-AL

Lightweight, alum. high performance ford water pump.

WP-6104-35S

Lightweight, billet alum. radius tooth HTD, water pump pulley.

896-20

35.276" long, reinforced, radius tooth HTD, 20mm wide belt.

CS-6102-44-AS & BG-6108-40S

Billet aluminum crankshaft pulley with bolt-on guides

DH-8101-WC-F4 or F3 (F3 shown)

Lightweight, billet aluminum, one piece drive hub, 3-bolt shown, a 4-bolt version is available. Bolt/end cap kit & spacer kit included.

High Amperage Switch 'SW - 9100 - A'

High amperage switch to protect the alt when charging the system.



Stand-alone Alternator Drive



SBC Alternator Drive Kit 2067-SB

Low mount SBC Alternator Drive Kit, also available for BBC

680-10 belt

26.772 inch long, reinforced, radius tooth HTD belt. Call for the belt that will best fit your application.

CS-6102-36 x 1/2"

1/2" Wide radius tooth HTD crank shaft pulley. Drives alternator.

DH-8101-NE-A

Lightweight, aluminum drive hub with built-in nut to turn-engine. Also is supplied with BEC-2109-C

AL-9101-SB-LM

Lightweight billet aluminum Alternator Mount, fits SBC, mounts next to balancer. Use with 35, 45, 65, 80 amp, 1-wire switchless alt.

AL-9105-24-A

Lightweight billet aluminum Radius Tooth HTD 24 tooth alternator pulley, .590" bore

AL-9101-B-NS

45 amp. 1-wire, switchless Alternator. Features internal fan. 5.8lb. lightweight setup. 35, 65, & 80 amp models are also available for this kit

ADR-9100-3.5"

Billet aluminum, adjusting rod. Allows adjustment for alternator, connects from the alternator to the upper water pump bolt.

High Amperage Switch 'SW - 9100 - A'

High amperage switch to protect the alt when charging the system.



BBC Alternator Drive Kit 2068-BB

Low mount BBC Alternator Drive Kit, also available for SBC

720-10 belt

28.346 inch long, reinforced, radius tooth HTD belt. Call for the belt that will best fit your application.

CS-6102-36 x 1/2"

1/2" Wide radius tooth HTD crank shaft pulley. Drives alternator.

DH-8101-C/DHM-8101-A

Lightweight, aluminum two piece BBC drive hub. Bolt kits BEC-2109-I & SK-2109-A supplied with hub.

AL-9101-BB-LM

Lightweight billet aluminum Alternator Mount, fits BBC, mounts next to balancer. Use with 35, 45, 65, 80 amp, 1-wire switchless alt.

AL-9105-24-A

Lightweight billet aluminum Radius Tooth HTD 24 tooth alternator pulley, .590" bore

AL-9101-C-NS

65 amp. 1-wire, switchless Alternator. Features internal fan. 5.8lb. lightweight setup. 35, 45, & 80 amp models are also available for this kit

ADR-9100-3.5"

Billet aluminum, adjusting rod. Allows adjustment for alternator, connects from the alternator to the upper water pump bolt.

SBC V-Belt WP Drive 3001-SB

Available for BB Chevy, SB Chevy, Ford and Chrysler

WP-3104-E-7"

Lightweight billet aluminum, 7" O.D. water pump pulley, double groove. For different

2 - CS-3102-WC-D-5.2"

When we designed our v-belt water pump drive kit we kept in mind the problem with equal belt tension & resolved it with our split-v design

DH-3102-A

Billet aluminum drive hub available for BB and SB Chevy. Hub is comes with EC-6111-WC-N x 1/2" end cap and DHS-3102-SK-BC shim kit.

Crankshaft Pulleys

- CS - 3102 - WC - D - 5.200"
- CS - 3102 - WC - E - 5.500"
- CS - 3102 - WC - F - 5.750"
- CS - 3102 - WC - G - 6.000"
- CS - 3102 - WC - H - 7.500"



Water Pump, Single-V

- WP - 3104 - A - 6" O.D.
- WP - 3104 - D - 7" O.D.



Water Pump, Double-V

- WP - 3104 - B - 6" O.D.
- WP - 3104 - E - 7" O.D.



SBC Serp WP Drive 1024-S

Available for BB Chevy, SB Chevy, Ford, and Chrysler
see page 36

Water Pump Pulleys

- WP - 5104 - WC - 4.5" O.D.
- WP - 5104 - WC - 5.0" O.D.



Crank Shaft Pulleys

- CS - 5102 - AA 2.000" O.D.
- CS - 5102 - A 2.500" O.D.
- CS - 5102 - B 2.800" O.D.
- CS - 5102 - C 3.000" O.D.
- CS - 5102 - D 3.250" O.D.
- CS - 5102 - E 3.500" O.D.
- CS - 5102 - F 3.750" O.D.
- CS - 5102 - G 4.000" O.D.
- CS - 5102 - H 4.250" O.D.
- CS - 5102 - I 4.500" O.D.
- CS - 5102 - J 4.750" O.D.
- CS - 5102 - K 5.000" O.D.

CS-5102-F-3.75"

Lightweight billet aluminum serpentine crankshaft pulley. Different sizes available.

WP-5104-WC- 5"

Lightweight billet aluminum, 5" O.D. water pump pulley. Different sizes are available to provide you with the ratio you need.

5PK-695

27.165" long, reinforced 5 groove, serpentine belt.

DH-8101-A, DHM-8101-A

Small Block Chevy billet aluminum drive hub with 1.25" long mandrel. Kit is supplied with through bolt, end cap kit, BEC-2109-D



Water Pumps and Related Accessories

Aluminum SBC Short Water Pump



WP-9104-SBC-AL

Steel SBC Short Water Pump



WP-9104-SBC-ST

BB Chevy, Alum. Water Pump



WP-9104-BBC-AL

Aluminum SB Ford Water Pump



WP-9104-SBF-AL

Mopar, Alum. Water Pump



WP-9104-MPR-AL

Choosing the correct water pump has never been easier. Let our 20+ years of experience help you choose the water pump for the completion of the ultimate drive kit, to achieve maximum horsepower & obtain optimum efficiency! Available for Small Block Chevy and Ford.

WP-9104 Series Water Pump Spacers (SBC)

Billet aluminum water pump spacers for Small Block Chevy. Available in either 1/4", 3/8", or 1/2" widths

- WP-9104-1/4"-SB (1/4" SBC)
- WP-9104-3/8"-SB (3/8" SBC)
- WP-9104-1/2"-SB (1/2" SBC)



WP-9104 Series Water Pump Spacers (BBC)

Billet aluminum water pump spacers for Big Block Chevys. Available either 3/8" wide, or 1/2" wide, 1/4" available via custom order.

- WP-9104-3/8"-BB (3/8" BBC)
- WP-9104-1/2"-BB (1/2" BBC)



RR-9104 Water Restrictor

Billet aluminum water restrictor. Place our restrictor in the water outlet of the radiator to cool your engine. We guarantee our unique restrictor to cool your engine. Call for complete details on cooling your engine. DO NOT combine with any other water restrictor.



WP-6104-A 1/16" WP Pulley Shims

Aluminum, .0625 (1/16") shims to properly and easily align the water pump pulley with the crankshaft pulley. Each shim made to have a flat surface. Available in sets of 3.

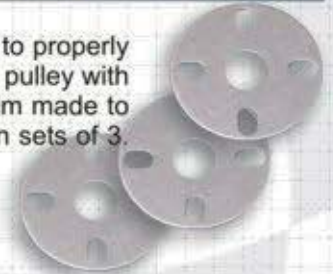

WP-6104-B Water Pump Pulley Bushing

Billet aluminum bushing with .750" outside diameter and a .625" inside diameter to allow all of our water pump pulleys to work on either a .625 shaft or .750 shaft. included with water pump pulley purchase.



WP-6104-C Adapter to Register Fan

Billet aluminum shaft extension for use with WP-9104-32 drive pulley that bolts to the front of the water pump pulley. Use this bushing when running a mechanical fan to properly register the fan to the shaft.



20mm Wide Radius Tooth HTD Belts

480 - 20 - 60	18.895
536 - 20 - 67	21.102
560 - 20 - 70	22.047
NEW 576 - 20 - 72	22.677
592 - 20 - 74	23.307
600 - 20 - 75	23.622
NEW 608 - 20 - 76	23.937
624 - 20 - 78	24.567
632 - 20 - 79	24.881
640 - 20 - 80	25.196
NEW 656 - 20 - 82	25.827
672 - 20 - 84	26.457
680 - 20 - 85	26.772
720 - 20 - 90	28.346
NEW 760 - 20 - 95	29.922
776 - 20 - 97	30.551
800 - 20 - 100	31.469
840 - 20 - 105	33.070
856 - 20 - 107	33.701
NEW 880 - 20 - 110	34.645
896 - 20 - 112	35.275
912 - 20 - 114	35.906
920 - 20 - 115	36.220
960 - 20 - 120	37.795
1040 - 20 - 130	40.944
1120 - 20 - 140	44.094



10mm Wide Radius Tooth HTD Belts

480 - 10 - 60	18.895
536 - 10 - 67	21.102
560 - 10 - 70	22.047
NEW 576 - 10 - 72	22.677
592 - 10 - 74	23.307
600 - 10 - 75	23.622
NEW 608 - 10 - 76	23.937
624 - 10 - 78	24.567
632 - 10 - 79	24.881
640 - 10 - 80	25.196
NEW 656 - 10 - 82	25.827
672 - 10 - 84	26.457
680 - 10 - 85	26.772
720 - 10 - 90	28.346
NEW 760 - 10 - 95	29.922
776 - 10 - 97	30.551
800 - 10 - 100	31.469
840 - 10 - 105	33.070
856 - 10 - 107	33.701
NEW 880 - 10 - 110	34.645
896 - 10 - 112	35.275
912 - 10 - 114	35.906
920 - 10 - 115	36.220
960 - 10 - 120	37.795

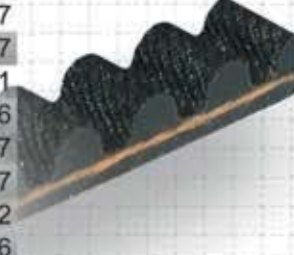

30mm Wide Radius Tooth HTD Belts

560 - 30 - 70	22.047
600 - 30 - 75	23.622
624 - 30 - 78	24.567
632 - 30 - 79	24.881
640 - 30 - 80	25.196
656 - 30 - 82	25.827
680 - 30 - 85	26.772

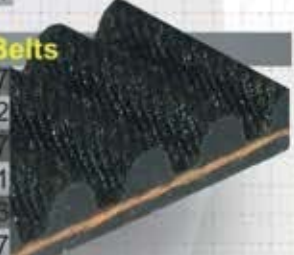

5 Groove Serpentine Poly-V Belts

5PK - 690	27.165"
5PK - 695	27.362"
5PK - 735	28.937"
5PK - 770	30.315"
5PK - 825	32.48"
5PK - 840	33.071"
5PK - 890	35.039"
5PK - 915	36.024"
5PK - 940	37.008"
5PK - 970	38.189"
5PK - 1000	39.370"
5PK - 1040	40.945"
5PK - 1065	41.929"



3/4" Inch Wide Square Tooth Gilmer Belts

255 - L - 075	25.50"
270 - L - 075	27.00"
285 - L - 075	30.00"
300 - L - 075	30.00"
322 - L - 075	32.20"



1/2" Inch Wide Square Tooth Gilmer Belts

187 - L - 050	18.70"
202 - L - 050	20.20"
210 - L - 050	21.00"
240 - L - 050	24.00"
255 - L - 050	25.50"
270 - L - 050	27.00"
285 - L - 050	28.50"
300 - L - 050	30.00"
320 - L - 050	32.00"
322 - L - 050	32.20"
345 - L - 050	34.50"
390 - L - 050	39.00"

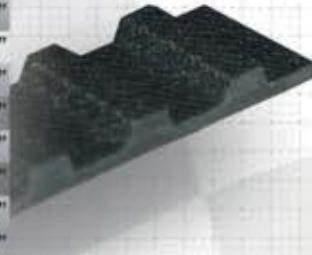

1" Inch Wide Square Tooth Gilmer Belts

187 - L - 100	18.70"
202 - L - 100	20.20"
210 - L - 100	21.00"
225 - L - 100	22.50"
240 - L - 100	24.00"
255 - L - 100	25.50"
270 - L - 100	27.00"
285 - L - 100	28.50"
300 - L - 100	30.00"
320 - L - 100	32.00"
322 - L - 100	32.20"
345 - L - 100	34.50"

