

PRODUCT CATALOG





Table of Contents

I.	CHROME PLATED EXHAUST TIPS AND MUFFLERS.....	1 - 3
II.	POLISHED T-304 STAINLESS STEEL EXHAUST TIPS.....	4 - 5
III.	JONES EXHAUST SPECIALITY TIPS	6
IV.	JONES EXHAUST CHROME EXHAUST TIPS.....	7 - 14
V.	MAX FLOW	15
VI.	FULL BOAR 16-GAUGE PERFORMANCE MUFFLERS	16
VII.	FULL BOAR FULL FLOW PERFORMANCE MUFFLERS.....	17
VIII.	FULL BOAR V-POWER REVERSABLE PERFORMANCE MUFFLERS.....	18
IX.	WELDING WIRE.....	18
X.	FULL BOAR QUIET TONE PERFORMANCE MUFFLERS.....	19
XI.	SUPER DUTY ROUND TRUCK MUFFLERS	20
XII.	ALUMINIZED GLASS PACK MUFFLERS	21 - 25
XIII.	ALUMINIZED TURBO TUBE MUFFLERS.....	26
XIV.	UNIVERSAL “U” AND “X” PIPES	27
XV.	SWINGING HANGER	28
XVI.	FLEX TUBES.....	29
XVII.	HEADER COLLECTORS AND CONNECTORS.....	30
XVIII.	DIRECT FLEX.....	31 - 32
XVIII.	FULL BOAR SLIP-ON MOTORCYCLE MUFFLERS	33 - 34
XX.	STAINLESS STEEL TUBING	35
XXI.	PRODUCT INDEX.....	INSIDE BACK COVER

Chrome & Stainless Exhaust Tips & Mufflers

CHROME PLATED EXHAUST TIPS & MUFFLERS



Chrome Mufflers/Resonators

Part #	Inlet Size (ID)	# Per Box	Overall Size (OD)
JCM212	2"	12	9" X 2.5"
JCM312	2"	12	12" X 3"
JCM316	2"	12	16" X 3"
JCM31222	2.25"	6	22" X 3.5"

Foreign Car Tips

Part #	Inlet Size (ID)	# Per Box	Overall Size (OD)
JFC112	1.5"	12	6" x 1.75"
JFC134	1.75"	12	6" x 2"
JFC200	2"	12	6" x 2.25"



Chevelle Tips

Part #	Inlet Size (ID)	# Per Box	Outlet Size	Length	Pipe Diameter (OD)
JWS200	2"	12	1.75" x 3"	7"	2.5"
JWT200	2"	12	1.75" x 3.75"	9"	3"
JWT212	2"	12	1.75" x 3.75"	9"	3"
JBT200	2"	12	2" x 3"	9"	3"
JST200	2"	12	2.75" x 2.875"	12"	3"
JWT214	2.25"	12	1.75" x 3.75"	9"	3"
JCT410	2.5"	6	1.75" x 4"	10"	4"



Inside Roll Pencil Tips

Part #	InletSize (ID)	# Per Box	Overall Size (OD)
IRPT134	1.75"	12	8" x 2.5"
IRPT200	2"	12	8" x 2.5"
IRPT214	2.25"	12	8" x 2.5"
IRPT212*	2.5"	12	8" x 2.5"

*Inlet swaged or expanded to ID size.



Inside Roll Pencil Tips

Part #	Inlet Size (ID)	# Per Box	Overall Size (OD)
IRPT3006	2"	12	6" x 3"
IRPT3012	2"	12	12" x 3"
IRPT3506	2.25"	6	6" x 3.5"
IRPT4006	2.5"	6	6" x 4"
IRPT4012	2.5"	6	12" x 4"
IRPT4018	2.5"	6	18" x 4"
IRPT5012	2.5"	4	12" x 5"
IRPT5018	2.5"	4	18" x 5"
IRPT3512	2.25"	6	12" x 3.5"
IRPT3512-3	3"	6	12" x 3.5"
IRPT4012-312	3.5"	6	12" x 4"
IRPT4016-312	3.5"	6	16" x 4"
IRPT5012-4	4"	4	12" x 5"

Dual Angle Resonator

Part #	Inlet Size (ID)	# Per Box	Dual Outlet (OD)	Overall Size
JDR200	2"	6	2.5"	14.5" x 6"
JDR214	2.25"	6	2.5"	14.5" x 6"
JDR212	2.5"	6	2.5"	14.5" x 6"

Custom Built Exhaust Tips

We can custom build chrome exhaust tips for you. Other suppliers cannot or will not do this. At Jones Exhaust, our motto is "Whatever it takes".

Allow 3-4 weeks for delivery on special orders.



Chrome & Stainless Exhaust Tips & Mufflers

CHROME PLATED EXHAUST TIPS & MUFFLERS



Truck Stacks

Part #	Inlet Size (OD)	# Per Box	Overall Size (OD)
JTS300	3" Mandrel bent. Includes shields and hardware.	1 pair (sold in pairs)	50" x 3"
JTK300	Truck shield kit - with hardware		



Dual Truck Tips (Left and Right)

Part #	Inlet Size (ID)	# Per Box	Dual Outlet (OD)	Overall Size
JTT200R	2"	12	2.25"	12" x 6.5"
JTT200L	2"	12	2.25"	12" x 6.5"



Dual Angle Tips

Part #	Inlet Size (ID)	# Per Box	Dual Outlet (OD)	Overall Size
JDA312-200	2"	4	3"	21" x 7.5"
JDA312-214	2.25"	4	3"	21" x 7.5"



Dual Trans Am Tips

Part #	Inlet Size (ID)	# Per Box	Overall Size
JDT200	2"	12	12" x 4.5"
JDT214	2.25"	12	12" x 4.5"



Dual Pencil Tips

Part #	Inlet Size (ID)	# Per Box	Dual Outlet (OD)	Overall Size
JDP200	2"	12	2.25"	11" x 5.5"



Dual Angle Cut Tips

Part #	Inlet Size (ID)	# Per Box	Dual Outlet (OD)	Overall Size
JDA200	2"	12	2.25"	11" x 5.5"



Inside Roll Angle Cut Tips

Part #	Inlet Size (ID)	# Per Box	Overall Size (OD)
IRAC312	2"	12	12" x 3"
IRAC316	2"	12	16" x 3"
IRAC324	2"	12	24" x 3"
IRAC31212	2.25"	6	12" x 3.5"
IRAC31212-3	3"	6	12" x 3.5"
IRAC31218	2.25"	6	18" X 3.5"
IRAC31222	2.25"	6	22" x 3.5"
IRAC412	2.5"	6	12" x 4"
IRAC418	2.5"	6	18" x 4"
IRAC422	2.5"	6	22" x 4"
IRAC7018	4"	1	7" x 18"
IRAC7018-5	5"	1	7" x 18"
IRAC8018	4"	1	8" x 18"
IRAC8018-5	5"	1	8" x 18"



Turn Down Tips

Part #	Inlet Size (ID)	# Per Box	Overall Size (OD)
JTD112	1.5"	12	8" x 1.75"
JTD134	1.75"	12	8" x 2"
JTD200	2"	12	9" x 2.25"
JTD214	2.25"	12	12" x 2.5"
JTD212*	2.5"	12	12" x 2.5"

*Inlet swaged or expanded to ID size.



Chrome & Stainless Exhaust Tips & Mufflers

CHROME PLATED EXHAUST TIPS & MUFFLERS



Pencil Tips

Part #	Inlet Size (ID)	# Per Box	Overall Size (OD)
JPT112	1.5"	12	8" x 1.75"
JPT134	1.75"	12	8" x 2"
JPT200	2"	12	9" x 2.25"
JPT214	2.25"	12	9" x 2.5"
JPT212	2.5"	12	9" x 2.75"
JPT312	2"	12	12" x 3"
JPT312-3*	3"	12	12" x 3"
JPT316	2"	12	16" X 3"
JPT320-3*	3"	12	20" x 3"
JPT324	2"	12	24" x 3"
JPT31212	2.25"	6	12" x 3.5"
JPT31212-3	3"	6	12" x 3.5"
JPT31218	2.25"	6	18" x 3.5"
JPT31220	2.25"	6	20" x 3.5"
JPT31220-3	3"	6	20" x 3.5"
JPT412-4*	4"	6	12" x 4"
JPT416	2.5"	6	16" X 4"
JPT418-4*	4"	6	18" x 4"

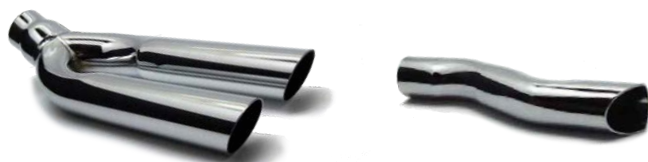

Specialty Chrome Tips

Part #	Inlet Size (ID)	# Per Box	Description
JGT200	2"	6	Mustang GT Tip
JDB200	1 3/4"	12	GM Compact Chrome Tailpipe

CHROME TIP DISPLAY STAND

-Versatile display to showcase exhaust tips

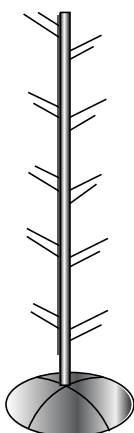

**Jones Chrome Tips
are made in America
by Americans**

Angle Cut Tips

Part #	Inlet Size (ID)	# Per Box	Overall Size (OD)
JAC112	1.5"	12	8" x 1.75"
JAC134	1.75"	12	8" x 2"
JAC200	2"	12	9" x 2.25"
JAC214	2.25"	12	9" x 2.5"
JAC212	2.5"	12	9" x 2.75"
JAC21218	2"	12	18" x 2.5"
JAC312	2"	12	12" x 3"
JAC312-214	2.25"	12	12" x 3"
JAC316	2"	12	16" x 3"
JAC316-214	2.25"	12	16" x 3"
JAC316-3*	3"	12	16" x 3"
JAC322	2"	12	22" x 3"
JAC322-3*	3"	12	22" x 3"
JAC324	2"	12	24" x 3"
JAC324-214	2.25"	12	24" x 3"
JAC31212	2.25"	6	12" x 3.5"
JAC31216	2.25"	6	16" x 3.5"
JAC31216-3	3"	6	16" x 3.5"
JAC31218	2.25"	6	18" x 3.5"
JAC31222	2.25"	6	22" x 3.5"
JAC31222-212	2.5"	6	22" x 3.5"
JAC31222-3	3"	6	22" x 3.5"
JAC412	2.5"	6	12" x 4"
JAC412-312	3.5"	6	12" x 4"
JAC412-4*	4"	6	12" x 4"
JAC416-312	3.5"	6	16" x 4"
JAC418	2.5"	6	18" x 4"
JAC418-3	3"	6	18" x 4"
JAC418-4*	4"	6	18" x 4"
JAC422	2.5"	6	22" x 4"
JAC422-3	3"	6	22" x 4"
JAC424	2.5"	6	24" x 4"
JAC512-4*	4"	4	12" x 5"
JAC518	2.5"	4	18" x 5"
JAC518-4	4"	4	18" x 5"
JAC524	2.5"	4	24" x 5"
JAC618-4	4"	4	6" x 18"
JAC618-212	2.5"	4	6" x 18"

* Inlet Swaged or expanded to ID size.

† Also available in gold plating until stock is depleted.

Part #	Description	# of Limbs
CT20	Floor Display	20



Chrome & Stainless Exhaust Tips & Mufflers

POLISHED T-304 STAINLESS STEEL EXHAUST TIPS



Speciality Tips

Part #	Type	Inlet Size (ID)	# Per Box	Outlet Size	Length
PCAM214SS	1	2.25"	10	7.75" x 2.25"	10"
PCAM234SS	1	2.75"	10	7.75" x 2.25"	10"
PDTU312SS	2	2.25"	5	3.5" (dual)	12"
PSDW4128SS*	3	2.25"	10	4.5"	8"
PDW3002SS*	4	2"	10	3"	6.25"
PDW41210SS*	5	2.25"	10	4.5"	10"
PRPT3507SS	5	2.25"	10	3.5"	7"
POR512SS	6	2.5"	10	5.5" x 3.5"	7.5"
PRESAC5012-4SS**	8	4"	1	5"	12"
PRESPT5012-4SS**	8	4"	1	5"	12"
PMS625LSS	7L	2.25"(Escalade Style)	10	6.25" x 3.75"	12"
PMS625RSS	7R	2.25"(Escalade Style)	10	6.25" x 3.75"	12"
PRS600SS	9	2.25"	10	6.00" Oval	9"
PRTU500SS	10	2.25"	10	5.00" Oval	9.5"

*Double Wall. **Weld-on only resonator tips.



Pencil Tips

Part #	Inlet Size (ID)	# Per Box	Overall Size (OD)
PPT200SS	2"	10	9" x 2.25"
PPT214SS	2.25"	10	9" x 2.5"
PPT212SS	2.5"	10	9" X 2.75"

Chevy Bowtie Tips

Part #	Inlet Size (ID)	# Per Box	Overall Size
JCB214-SS	2.25"	2	9" x 4.75"
JCB212-SS	2.5"	2	9" x 4.75"
JCB234-SS	2.75"	2	9" x 4.75"
JCB300-SS	3"	2	9" x 4.75"

*Stainless steel tips not designed for neck expansion.

Chrome & Stainless Exhaust Tips

STAINLESS STEEL EXHAUST TIPS



Angle Cut Tips

Part #	Inlet Size (ID)	# Per Box	Overall Size (OD)
PAC200SS	2"	10	9" x 2.25"
PAC214SS	2.25"	10	9" x 2.5"
PAC212SS	2.5"	10	9" x 2.75"
PAC312SS	2.25"	10	12" x 3"
PAC316SS	2.25"	10	16" x 3"
PAC318SS	2.25"	10	18" x 3"
PAC318-212SS	2.5"	10	3" x 18"
PAC324SS	2.25"	10	24" x 3"
PAC31212SS	2.25"	10	12" x 3.5"
PAC31216SS	2.25"	10	16" x 3.5"
PAC31218SS	2.25"	10	18" x 3.5"
PAC31218-212SS	2.5"	10	18" x 3.5"
PAC31222-214SS	2.25"	10	22" x 3.5"
PAC31222SS	2.5"	10	22" x 3.5"
PAC412SS	2.5"	10	4" x 12"
PAC418SS	2.5"	10	18" x 4"
PAC422-214SS	2.25"	10	22" x 4"



Inside Roll Angle Cut Tips

Part #	Inlet Size (ID)	# Per Box	Overall Size (OD)
PRAC316SS	2.25"	10	16" x 3"
PRAC31212SS	2.25"	10	12" x 3.5"
PRAC31216SS	2.25"	10	16" x 3.5"
PRAC31218SS	2.25"	10	18" x 3.5"
PRAC31218-212SS	2.5"	10	18" x 3.5"
PRAC31222SS	2.5"	10	22" x 3.5"
PRAC418SS	2.5"	10	18" x 4"
PBRAC4012-4SS*	4"	1	12" x 4"
PBRAC5012-4SS*	4"	1	12" x 5"
PBRAC5012-5SS*	5"	1	12" x 5"
PBRAC5018-4SS*	4"	1	18" x 5"
PBRAC5018-5SS*	5"	1	18" x 5"
PBRAC6012-4SS*	4"	1	6" x 12"
PBRAC6012-5SS*	5"	1	6" x 12"
PBRAC6018-4SS*	4"	1	18" x 6"
PBRAC6018-5SS*	5"	1	18" x 6"

*Bolt-on

**Bolt-on, Double wall



Inside Roll Straight Cut Tips

Part #	Inlet Size (ID)	# Per Box	Overall Size (OD)
PBRPT5012-4SS*	4"	1	12" x 5"
PBRPT5012-5SS*	5"	1	12" x 5"
PBDWPT5012-4SS**	4"	1	12" x 5"
PBDWPT5012-5SS**	5"	1	12" x 5"



Turn Down Tips

Part #	Inlet Size (ID)	# Per Box	Overall Size (OD)
PTD300SS	3"	10	16" x 3"
PTD312SS	3.5"	10	16" x 3.5"
PTD400SS	4"	10	18" x 4"

*Stainless steel tips not designed for neck expansion.



Jones Exhaust Exclusive Specialty Tips

Product Description:

New textured powder-coated tips. Greater durability than chrome.



Jones Black Vein & Silver Vein Tips

Part #	Description	Overall Size (OD)
JAC316-BV	2" Inlet Black Vein Angle Cut	16" x 3"
JAC316-SV	2" Inlet Silver Vein Angle Cut	16" x 3"
JAC31212-BV	2.25" Inlet Black Vein Angle Cut	12" x 3.5"
JAC31212-SV	2.25" Inlet Silver Vein Angle Cut	12" x 3.5"
IRAC31212-BV	2.25" Inlet Black Vein Rolled Angle	12" x 3.5"
IRAC31212-SV	2.25" Inlet Silver Vein Rolled Angle	12" x 3.5"
JAC31218-BV	2.25" Inlet Black Vein Angle Cut	18" x 3.5"
JAC31218-SV	2.25" Inlet Silver Vein Angle Cut	18" x 3.5"
IRAC31218-BV	2.25" Inlet Black Vein Rolled Angle	18" x 3.5"
IRAC31218-SV	2.25" Inlet Silver Vein Rolled Angle	18" x 3.5"
JAC418-BV	2.5" Inlet Black Vein Angle Cut	18" x 4"
JAC418-SV	2.5" Inlet Silver Vein Angle Cut	18" x 4"

Other sizes available via special order

Product Description:

Known in the plating industry as Black Chrome and called Black Pearl by others, our "Midnight Pearl" exhaust tips are tank plated with a special version of our nickel plating which results in a dark mirrored image.

Because we use more nickel plating than any of our competitors, combined with the unique plating, hardening and clear coating process, we have produced a top quality tip that is both durable and long-lasting. Available in 4 Popular Sizes



Midnight Pearl Exhaust Tips

Part #	Inlet (ID)	Overall (OD)	Style
JAC316-MP	2"	16" x 3"	Angle Cut
JAC31218-MP	2.25"	18" x 3.5"	Angle Cut
IRAC31218-MP	2.25"	18" x 3.5"	Rolled Angle Cut
JAC418-MP	2.5"	18" x 4"	Angle Cut



Camo Tip!

Part number
JAC31218-C

2.25 (inlet)
18 x 3.5 overall

Camo Pattern is Vista

***Not recommended for V-8 engines unless equipped with dual exhaust.**

Chrome & Stainless Exhaust Tips

STAINLESS STEEL EXHAUST TIPS



J303512AC15 *	3 X 3-1/2 X 12" ANGLE
J243522AC15 *	2-1/4" X 3-1/2" X 22"
J243518AC15 *	2-1/4" X 3-1/2" X 18"
J244012AC	2-1/4 X 4" X 12" ANGLE
J304012AC	3" X 4" X 12" ANGLE
J244018AC	2-1/4" X 4" X 18" ANGLE
J304018AC	3" X 4" X 18" ANGLE
J254022AC	2-1/2" X 4" X 22" ANGLE
J254022AC15	2-1/2" X 4" X 22" ANGLE
J304022AC	3" X 4" X 22" ANGLE
J8912AC *	4" X 5" X 12" ANGLE
J8915AC	4" X 5" X 15" ANGLE
J8012AC	4" X 6" X 12" ANGLE
J9012AC	5" X 6" X 12" ANGLE
J8015AC	4" X 6" X 15" ANGLE
J9015AC	5" X 6" X 15" ANGLE
J407015AC	4" X 7" X 15" ANGLE
J507015AC	5" X 7" X 15" ANGLE
J508015AC	5" X 8" X 15" ANGLE



* Some tips are available with 15 degree angles



J8912ACB	4" X 5" X 12" ANGLE BOLT
J8015ACB	4" X 6" X 15" ANGLE BOLT
J9015ACB	5" X 6" X 15" ANGLE BOLT
J8018ACB	4" X 6" X 18" ANGLE BOLT
J407015ACB	4" X 7" X 15" ANGLE BOLT
J407018ACB	4" X 7" X 18" ANGLE BOLT
J408015ACB	4" X 8" X 15" ANGLE BOLT
J508015ACB	5" X 8" X 15" ANGLE BOLT
J408018ACB	4" X 8" X 18" ANGLE BOLT

BLACK CHROME

J243518AC2	2-1/4" X 3-1/2" X 18	Angle Cut
J243522AC2	2-1/4" X 3-1/2" X 22	Angle Cut
J243016AC2	2-1/4" X 3" X 16"	Angle Cut
J244018AC2	2-1/4" X 4" X 18"	Angle Cut



J405015TDBK 4" X 5" X 15" Turn Down Black Powder

JST014

2-1/2" X 4 1/2" x 7" Rolled Slant w/Neck



All Part Description are written in ID X OD X Length



Chrome & Stainless Exhaust Tips

STAINLESS STEEL EXHAUST TIPS

J4718AC	2-1/4" X 3-1/2" X 18"	Angle w/Neck
PACN31218-212SS	2-1/2" X 3-1/2" X 18"	Angle w/Neck
J4722AC	2-1/4" X 3-1/2" X 22"	Angle w/Neck
J4616AC	2-1/4" X 3" X 16"	Angle w/Neck
J5818AC	2-1/2" X 4" X 18"	Angle w/Neck
J5822AC	2-1/2" X 4" X 22"	Angle w/Neck
J4515AC	4" X 5" X 15"	Angle w/Neck
J5615AC	5" X 6" X 15"	Angle w/Neck



J4718ACK 2-1/4" X 3-1/2" X 18" Black Powder



PCAM214SS 2-1/4" X 7-3/4" X 2-1/4" X 10"
PCAM234SS 2-3/4" X 7-3/4" X 2-1/4" X 10"
CAMARO Straight

JST027R

2-1/2" X 8" X 2 1/4" CAMARO Right Side Inlet

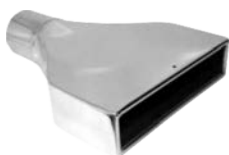

JST027H 2-1/2" X 8" X 2 1/4" CAMARO Straight

JST027G

2 1/2" X 6" X 2 1/4" CAMARO Straight

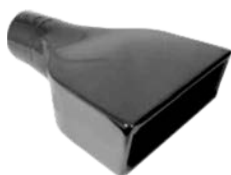

JST027E2

2-1/2" X 8" X 2 1/4" CAMARO Slant Black Chrome

J3409TD
J5612TD
J4509TD

2" X 2-1/4" X 9" Turn Down
2-1/2" X 2-3/4" X 12" Turn Down
2-1/4" X 2-1/2" X 9" Turn Down



J6715TD 3" X 3-1/2" X 15" Turn Down
J405015TD 4" X 5" X 15" Turn Down

JST132

2-1/4" X 3-1/2" X 7" Round Rolled Slant



** All Camaro Style Tips are seamless*

Chrome & Stainless Exhaust Tips & Mufflers

STAINLESS STEEL EXHAUST TIPS



JST027EK

2 1/4" X 8" X 2 1/4" CAMARO Slant Black Powder

JST027D2

2 1/2" X 6" X 2 1/4" CAMARO Slant Black Chrome



**PCAMS214SS-6
PCAMS214SS
JST027E
JST027D**

**2-1/4" X 6" X 2-1/4"
2-1/4" X 8" X 2-1/4"
2-1/2" X 8" X 2-1/4"
2-1/2" X 6" X 2 -1/4"
CAMARO Slant**

JST048

2 1/4" x 3" X 10" Double Wall Round Turn Up



JST130

3"X4"x16"Dual Oval

JST084

2 1/4" x 3" x 9" Dual Oval Slant



JST0792

2-1/4" x 3-1/2' x 3" x 9" Dual Oval Slant Black Chrome

JST026S

2-1/4" X 3-1/2" X 12" DUAL Round Rolled





Chrome & Stainless Exhaust Tips

STAINLESS STEEL EXHAUST TIPS

2 1/4" x 5 1/2" x 3 3/8" x 11 1/2"

JST120R
JST120L

S.S.DUAL"D" RIGHT
S.S.DUAL"D" LEFT



JST139

2-1/2"X4"X5"Double Wall Angle

JST140

3" X 4" X 5" Double Wall Angle



JST538NS

4" X 5" X 13" Double Wall Bolt Angle

JST051

2-1/4" X 4-1/2" x 8" Double Wall Cobweb



JST121

2 1/4" X 5 1/2" X 3 1/2" X 14
Double Wall Dual Oval

JST123

2-1/2" x 3-1/2" x 13" Double-Wall Dual Round Slant



JST080

3"X 3" X 13" Double Wall Dual Slant

J8912PT

4" X 5" X 12" Bolt Pencil



J405012PT

4" X 5" X 12" Rolled Pencil

Chrome & Stainless Exhaust Tips & Mufflers

STAINLESS STEEL EXHAUST TIPS

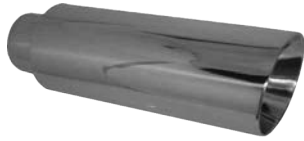

JST013B12

2-1/4" X 3 -1/2" X 12" Double Wall Angle

JST013B16
JST25013B16

2-1/4" X 3-1/2" X 16" Double Wall Angle
2-1/2" X 3-1/2" X 16" Double Wall Angle



JST040

2-1/4" X 3-3/4" X 7" Double Wall Oval

JST013A12
JST013A16
JST013A
JST25013C16

2-1/4" X 3" X 12
2-1/4" X 3" X 16"
2-1/4" X 3" X 8"
2-1/2" X 4" X 16"
Double Wall Oval Slant



JST30013C12

3" X 4" X 12" Double Wall Angle

JST40013D12

4" X 5" X 12" Double Wall Angle

JST116

2 1/4" X 4 1/2" X 3 1/2" X 6" Double Wall Oval



JST053

2-1/4" X 3-3/4" X 3-1/2" X 6-1/2"
Rolled Oval Slant

JST039B

2-1/4" X 5-1/2" x 3-1/2" X 12"
Double Wall Rolled Oval



JST007A
J243512PT
J253518PT
J243518PT
J243522PT

1-3/4" X 2 X 10"
2-1/4" X 3-1/2" X 12"
2-1/2" X 3-1/2" X 18
2-1/4" X 3-1/2" X 18
2-1/2" X 3-1/2" x 22



Chrome & Stainless Exhaust Tips

STAINLESS STEEL EXHAUST TIPS



JST075

2-1/4" X 4" X 9" Double Wall Rolled Round

JST006

2-1/4" X 3 1/2" X 8" Double Wall Resonated Tip



JST538N

4' X 5" X 13" Double Wall Bolt-on Straight

**JST009
JST136A
JST133
JST136B
JST136C**

**2-1/4" X 3" X 7"
2-1/4" X 3" X 8"
2-1/4" X 3-1/2" X 4"
2-1/4" X 3-1/2" X 8"
2-1/4" X 4" X 8"**

**Double Wall Straight
Double Wall Straight
Double Wall Straight
Double Wall Slate
Double Wall Slate**



**JST042
JST041**

**2-1/4" x 3-3/4" x 3 x 7 Double Wall Slant Square
2-1/4" x 3-3/4" x 3 x 7 Double Wall Soft Square**

JST070

2-1/4" X 4" X 3-1/2" X 7" Double Wall Square



**JST092
JST093**

**1-3/4" X 2-1/2" x 5"
1-1/2" X 2-1/2" X 5**

Foreign Double Wall Round

**J3707
JST043S2**

**2-1/4" X 10"
2-1/4" X 5-1/2" X 9"
Oval Rolled Slant**

Black Chrome



JST081K

**2-1/4" X 6" X 2-1/2" X 9"
Rolled Oval Angle Black Powder**

JST062

**2-1/4" X 4-1/2" X 3-3/4" X 7"
Rolled Oval Resonated Slant**



Chrome & Stainless Exhaust Tips & Mufflers

STAINLESS STEEL EXHAUST TIPS



JST119

2 1/4" X 5-1/2" x 2 3/4" X 7" Double Wall Resonated Oval

JST118

2 1/4" X 5-1/2" x 2 3/4" X 7" Resonated Oval



JST090

3" X 4-1/4" X 1 3/4" X 14" MOPAR Oval Slant



JST091

2-1/4" X 3-3/4" x 1 3/4" x 17" MOPAR Rectangle Slant



J7815RAB

3-1/2 X 4 X 15" Rolled Angle- BOLT

J6815RAB

3 X 4 X 15" Rolled Angle-BOLT

J8915RAB

4 X 5 X 15" Rolled Angle -BOLT

J8015RAB

4 X 6 X 15" Rolled Angle- BOLT

J9015RAB

5 X 6 X 15" Rolled Angle- BOLT

J253512RAC

2-1/2" X 3-1/2" X 12" Rolled Angle

J303512RAC

3" X 3-1/2" X 12" Rolled Angle

J243012RAC

2-1/4" X 3" X 12" Rolled Angle

J243522RAC

2-1/4" X 3-1/2" X 22" Rolled Angle

J244012RAC

2-1/2" X 4" X 12" Rolled Angle

J354012RAC

3-1/2" X 4" X 12" Rolled Angle

J304012RAC

3" X 4" X 12" Rolled Angle

J304015RAC

3" X 4" X 15" Rolled Angle

J244018RAC

2-1/4" X 4" X 18" Rolled Angle

J355012RAC

3-1/2" X 5 X 12" Rolled Angle

J405014RAC

4" X 5" X 14" Rolled Angle

J355015RAC

3-1/2" X 5 X 15" Rolled Angle

J405018RAC

4" X 5" X 18" Rolled Angle

J506012RAC

5" X 6" X 12" Rolled Angle

J506014RAC

5" X 6" X 14" Rolled Angle

J406015RAC

4" X 6" X 15" Rolled Angle

J506015RAC

5" X 6" X 15" Rolled Angle

J406018RAC

4 X 6 X 18" Rolled Angle

J506018RAC

5" X 6" X 18" Rolled Angle

J407015RAC

4 X 7 X 15" Rolled Angle

J507015RAC

5 X 7 X 15" Rolled Angle





Chrome & Stainless Exhaust Tips

STAINLESS STEEL EXHAUST TIPS

J405014RACB
J506014RACB

4" X 5" X 14" Rolled Angle Cut Bolt-on Vented
5" X 6" X 14" Rolled Angle Cut Bolt-on Vented



J407015RACB **4" X 7" X 15" Rolled Bolt**
J507015RACB **5" X 7" X 15" Rolled Bolt**
J407018RACB **4" X 7" X 18" Rolled Bolt**
J408015RACB **4" X 8" X 15" Rolled Bolt**
J508015RACB **5" X 8" X 15" Rolled Bolt**

J406015RACBK
J506015RACBK
J407015RACBK
J507015RACBK
J408015RACBK
J508015RACBK

4X6X15 BOLT Black Powder
5X6X15 BOLT Black Powder
4X7X15 BOLT Black Powder
5X7X15 BOLT Black Powder
4X8X15 BOLT Black Powder
5X8X15 BOLT Black Powder



Rolled Angle



J303512RACK **3 X 3-1/2 X 12**
J243518RAC2 **2-1/4" X 3-1/2" X 18"**
J243522RAC2 **2-1/4" X 3-1/2" X 22"**
J243016RAC2 **2-1/4" X 3" X 16"**
J304012RACK **3" X 4" X 12"**
J506015RACK **5" X 6" X 15"**

Black Powder
Black Chrome
Black Chrome
Black Chrome
Black Powder
Black Powder

J4712RAC
J4718RAC
PRACN3121822SS
J4722RAC
J4616RAC
PRACB31218212SS
J5812RAC
J5818RAC
J4515RAC
J5615RA

2-1/4" X 3-1/2" X 12" **ROLLED ANGLE**
2-1/4" X 3-1/2" X 18" **ROLLED ANGLE**
2-1/2" X 3-1/2" X 18" **ROLLED ANGLE**
2-1/4" X 3-1/2" X 22" **ROLLED ANGLE**
2-1/4" X 3" X 16" **ROLLED ANGLE**
2-1/2" X 3-1/2" X 18" **ROLLED ANGLE**
2-1/2" X 4" X 12" **ROLLED ANGLE**
2-1/2" X 4" X 18" **ROLLED ANGLE**
4" X 5" X 15" **ROLLED ANGLE**
5" X 6" X 15" **ROLLED ANGLE**



J4616RACK **2-1/4" X 3" X 16" Black Powder**
J5812RACK **2-1/4" X 4" X 12" Black Powder**
J244018RAC2 **2-1/2" X 4" X 18" Black Chrome**
J5818RACK **2-1/2" X 4" X 18" Black Powder**

2-1/4" X 6" X 2-1/2" X 9"
Rolled Oval Angle

JST081



MAX FLOW



409 STAINLESS STEEL UNIVERSAL MUFFLER

ALL MUFFLERS ARE REVERSABLE

Aluminized Muffler Installation Stand

NEW PRODUCT

Makes muffler installation much easier!

Muffler installations are now easier using the NEW muffler installation stand from Jones Exhaust.

The stand is made of 16 gauge aluminized steel and will extend upward to a height of 7 feet.

Part # JMS1

Jones Exhaust: 100% Fullfillment of Orders and Expectations



4 X 9 OVAL 14" MUFFLER 20" OVERALL

MF1224	2" X 2" OFFSET/CENTER
MF1225	2 1/4" X 2 1/4" OFFSET/CENTER
MF1226	2 1/2" X 2 1/2" OFFSET/CENTER
MF1229	3" X 3" OFFSET/CENTER
MF1234	2" X 2" OFFSET/OFFSET
MF1235	2 1/4" X 2 1/4" OFFSET/OFFSET
MF1236	2 1/2" X 2 1/2" OFFSET/OFFSET

4 X 9 OVAL 18" MUFFLER 24" OVERALL

MF1255	2 1/4" X 2 1/4" OFFSET/CENTER
MF1256	2 1/2" X 2 1/2" OFFSET/CENTER
MF1259	3" X 3" OFFSET/CENTER
MF1265	2 1/4" X 2 1/4" OFFSET/OFFSET
MF1266	2 1/2" X 2 1/2" OFFSET/OFFSET

5" X 8" OVAL 18" MUFFLER 24" OVERALL

MF2255	2 1/4" X 2 1/4" OFFSET/CENTER
MF2256	2 1/2" X 2 1/2" OFFSET/CENTER
MF2259	3" X 3" OFFSET/CENTER

5" X 8" OVAL 24" MUFFLER 30" OVERALL

MF2289	3" X 3" OFFSET/CENTER
--------	-----------------------

5 X 8 OVAL 14" MUFFLER 20" OVERALL

MF2149	2 1/4" X 2 1/4" CENTER/DUAL
MF2158	2 1/2" X 2 1/2" CENTER/DUAL
MF2198	3" X 2 1/2" CENTER/DUAL

5" X 8" OVAL 18" MUFFLER 24" OVERALL (Camaro)

MF2265	2 1/2" X 2 1/2" OFFSET/DUAL
--------	-----------------------------

5 X 8 OVAL 18" MUFFLER 24" OVERALL

MF2251	2 1/2" X 2 1/4" CENTER/DUAL
MF2267	2 1/2" OFFSET/3 & 2 1/2" DUAL
MF2268	2 1/2" X 2 1/2" CENTER/DUAL
MF2278	3" X 2 1/4" CENTER /DUAL
MF2288	3" X 2 1/2" CENTER/DUAL
MF2298	3" X 3" CENTER/DUAL

5 X 8 OVAL 18" MUFFLER 24" OVERALL

MF2468	2 1/2" X 2 1/2" DUAL/DUAL
MF2469	3" X 3" DUAL/ DUAL

5 X 11 OVAL 22" MUFFLER 28" OVERALL

MF2589	3" X 3" OFFSET/CENTER
MF2588	3" X 2 1/2" CENTER/DUAL
MF2579	3" X 3" CENTER/CENTER
MF2590	3" X 3" CENTER/DUAL

5 X 11 OVAL 22" MUFFLER 28" OVERALL

MF2568	2 1/2" X 2 1/2" DUAL/DUAL
--------	---------------------------

4 X 14 ROUND 14" MUFFLER 20" OVERALL

JXS0445	2 1/4" X 2 1/4" CENTER
JXS0416	2 1/2" X 2 1/2" CENTER

4 X 18 ROUND 18" MUFFLER 24" OVERALL

JXS0425	2 1/4" X 2 1/4" CENTER
JXS0426	2 1/2" X 2 1/2" CENTER

7 X 24 ROUND 24" MUFFLER 30" OVERALL

JXS2772	4" X 4" CENTER
---------	----------------

Jones Exhaust Systems, Inc.









4" X 9" Ovals / 13" Body & 19" Overall
 FLOW DEFLECTOR DIRECTIONAL PERFORMANCE MUFFLERS
 SINGLE CHAMBER RACE MUFFLERS

Design Improvements:

- ** 16 gauge aluminized outer shell
- ** 16 gauge aluminized baffles & end caps
- ** 16 gauge aluminized necks
- ** 100% mig welded for extra durability
- ** Flow Deflector Technology

Performance & Sound Technology:

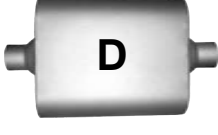
- Allows for maximum flow & power gains.
- Produces a sound that is powerful & aggressive.
- Durable & Economical. The Sound your customer craves

	Inlet I.D.		Outlet I.D.		Inlet I.D.		Outlet I.D.
 <p>A</p>	2"	FB2042 FB2442	2"	 <p>C</p>	2.25"	FB4422 FB5422	(2) 2.25"
	2.25"		2.25"		2.5"		2.5"
 <p>B</p>	2"	FB2043 FB2443 FB2543 FB3043	2"	 <p>crossflow/ transverse</p>	2.5"	FB2583	(2) 2.5"
	2.25"		2.25"		2.5"		2.5"
	2.5"		3"		3"		2.5"
 <p>F</p>	(2) 2.25"	FB4554	(2) 2.25"	 <p>D</p>	2.5"	FB2540	2.5"
 <p>A</p>	2"	FB2041 FB2441 FB2541 FB3041	2"				
	2.25"		2.25"				
	2.5"		2.5"				
	3"		3"				

Out-Performs!
Out-Lasts!
Out-Sounds!

4" X 9" Ovals / 17" Body & 23" Overall



FB3051 3" Offset / Center



FB4553 3" Center / Dual 2.25"

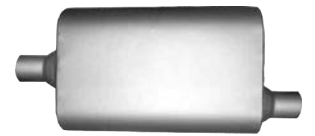

FB3052 3" Center / Offset

Part Numbers

Single Chamber Race Mufflers
 4" X 9" Oval, 6.5" Body, 13" Overall



All Welded 16 Gauge Aluminized Steel Single Chamber Design.

FB425
 2.5" ID Inlet
 2.25" ID Dual Outlets

FB426
 2.5" ID Inlet
 2.5" ID Outlet
 Center - Center

FB427
 3" ID Inlet
 2.5" ID Dual Outlets

FB428
 3" ID Inlet
 3" ID Outlet
 Center - Center

FB429
 3" ID Inlet
 2.25" ID Dual Outlets

FB430
 2.25" ID Inlet
 2.25" ID Outlet
 Offset / Offset



Full Boar Performance Mufflers

FULL FLOW TRUCK SERIES LARGE-BODY MUFFLERS

Full Flow 5" x 11" Oval - 19.5" Body x 25" Overall - 3" Cores



2.25"	F523A	2.25"
2.5"	F524A	2.5"
2.75"	F525A	2.75"
3"	F526A	3"



2.5"	F524B	2.5"
2.75"	F525B	2.75"
3"	F526B	3"



2.5"	F524C	2.5"
3"	F526C	3"



Can be used for a crossflow transverse muffler

2.25"	F523E	2.25"
2.5"	F524E	2.5"



3"	F5264F	2.5"
----	--------	------



3"	F5263G	2.25"
----	--------	-------

Full Flow 5" x 11" Oval - 22.5" Body x 29" Overall - 3" Cores



2.75"	F535A	2.75"
3"	F536A	3"



2.75"	F535B	2.75"
3"	F536B	3"



3"	F5362C	2"
3"	F5363C	2.25"
3"	F5364C	2.5"
3"	F536C	3"



Can be used for a crossflow transverse muffler

2.5"	F534E	2.5"
------	-------	------



2.25"	F533F	2.25"
-------	-------	-------

ROUND Full Flow Performance Mufflers

Full Boar large body and large core performance mufflers are designed specifically for gas, diesel truck, big block SUVs and motor home applications. They can significantly improve acceleration and towing power while simultaneously increasing fuel economy up to four miles per gallon in some motor home and diesel truck applications.



6" Round

Inlet	Item ID	Outlet	Body Length	Overall Length
2.5"	F626-4D	2.5"	26.5"	33"
3"	F626-6D	3"	26.5"	33"
3.5"	F626-7D	3.5"	26.5"	33"
4"	F624-8D	4"	24"	29"
4"	F626-8D	4"	26.5"	33"

7" Round

Inlet	Item ID	Outlet	Body Length	Overall Length
3"	F726-6D	3"	26.5"	33"
3.5"	F726-7D	3.5"	26.5"	33"
4"	F726-8D	4"	26.5"	33"

8" Round

Inlet	Item ID	Outlet	Body Length	Overall Length
4"	F824-8D	4"	24"	30"
5"	F824-9D	5"	24"	30"
3"	F830-6D	3"	30"	36"
3.5"	F830-7D	3.5"	30"	36"
4"	F830-8D	4"	30"	36"

Straight Through Louvered Core Design!
ALL Units Are 100% Reversible

DIESEL MUFFLERS with PERFORATED CORE



5" X 12" AP5012S-4 4" ID & CORE

5" X 18" AP5018S-4 4" ID & CORE



Want performance without the sound? See page 10 for our "Quiet Tone" Full Performance Mufflers!



Full Boar Performance Mufflers

V-POWER SERIES (ALL UNITS REVERSIBLE-WITH NO EFFECT ON PERFORMANCE)

This patented "flow deflector" technology provides superior flow of exhaust gases and results in increased horsepower, torque, and fuel economy. All with the sound you crave!

4" x 9.75" Oval - 13" Body x 18.5" Overall



1.75"	V411A	1.75"	1.75"	V411B	1.75"	2"	V412C	2"	2"	V412D	2"
2"	V412A	2"	2"	V412B	2"	2.25"	V4132C	2"	2.25"	V413D	2.25"
2.25"	V413A	2.25"	2.25"	V413B	2.25"	2.25"	V413C	2.25"	2.5"	V414D	2.5"
2.5"	V414A	2.5"	2.5"	V414B	2.5"	2.25"	V4134C	2.5"	3"	V416D	3"
2.75"	V415A	2.75"	2.75"	V415B	2.75"	2.5"	V4142C	2"	3.5"	V417D	3.5"
3"	V416A	3"	3"	V416B	3"	2.5"	V4143C	2.25"			
3.5"	V417A	3.5"	3.5"	V417B	3.5"	2.5"	V414C	2.5"			

Can be used for a crossflow transverse muffler

3"	V4162C	2"
3"	V4163C	2.25"
3"	V4164C	2.5"
3"	V416C	3"

The Only Performance Muffler in the Industry That Utilizes "Flow Deflector" Technology & is 100% Reversible!



2.25"	V413E	2.25"	2.25"	V413F	2.25"	2.25"	V4132G	2"	2.5"	V414R	2.5"
2.5"	V4143E	2.25"	2.5"	V414F	2.5"						
2.5"	V414E	2.5"									
3"	V416E	3"									

Can be used for a crossflow transverse muffler

Jones Exhaust Welding Wire

PART #	SIZE	WEIGHT (lb)
WW03011	.030	11
WW03033	.030	33
WW03511	.035	11
WW03533	.035	33
WW03544	.035	44
WW02311	.023	11
WW02333	.023	33



2.25"	V4132T	2"	2"	V412U	2"
2.25"	V4134T	2.5"	2.25"	V413U	2.25"
2.5"	V4143T	2.25"	2.5"	V414U	2.5"
3"	V4164T	2.5"			

Full Boar Heavy Duty All-Welded Aluminized Mufflers



QUIET TONE OVAL HEAVY DUTY MUFFLER

Full Boar Quiet Tone Series Offers The Benefits Of Performance Without The Noise!

- Mild exhaust tone, incorporating baffle designs to produce reduced interior sound levels.
- Great for tow vehicles, SUVs, vans and late-model trucks where sound control is as important as horsepower development.



4" x 9.75" Oval

ID	Part #	ID	Body	Overall	ID	Part#	ID	Body	Overall	ID	Part #	ID	Body	Overall
1.75"	Q411A	1.75"	13"	18.5"	1.75"	Q411B	1.75"	13"	18.5"	2.25"	Q413C	2.25"	13"	18.5"
2"	Q412A	2"	13"	18.5"	2"	Q412B	2"	13"	18.5"	2.5"	Q4142C	2"	13"	18.5"
2.25"	Q413A	2.25"	13"	18.5"	2.25"	Q413B	2.25"	13"	18.5"	2.5"	Q4143C	2.25"	13"	18.5"
2.5"	Q414A	2.5"	13"	18.5"	2.5"	Q414B	2.5"	13"	18.5"	2.5"	Q414C	2.5"	13"	18.5"
3"	Q416A	3"	13"	18.5"	3"	Q416B	3"	13"	18.5"	2.75"	Q4153CSP	2.25"	13"	18.5"
										3"	Q4162C	2"	13"	18.5"
										3"	Q4163C	2.25"	13"	18.5"
										3"	Q4164C	2.5"	13"	18.5"

All Units Are 100% Reversible!

5" x 11" Oval

ID	Part #	ID	Body	Overall	ID	Part#	ID	Body	Overall	ID	Part #	ID	Body	Overall
2.25"	Q523A	2.25"	19.5"	25"	2.5"	Q524B	2.5"	19.5"	25"	2.5"	Q524C	2.5"	19.5"	25"
2.5"	Q524A	2.5"	19.5"	25"	3"	Q526B	3"	19.5"	25"	3"	Q5263C	2.25"	19.5"	25"
3"	Q526A	3"	19.5"	25"	3"	Q536B	3"	22.5"	29"	3"	Q526C	3"	19.5"	25"
3"	Q5365A	2.75"	22.5"	29"						2.75"	Q5353C	2.25"	22.5"	29"
3"	Q536A	3"	22.5"	29"						3"	Q5362C	2"	22.5"	29"
										3"	Q5363C	2.25"	22.5"	29"
										3"	Q5364C	2.5"	22.5"	29"
										3"	Q536C	3"	22.5"	29"

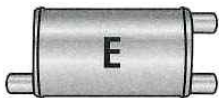

Can be used for a crossflow transverse muffler

4" x 9.75" Oval



ID	Part #	ID	Body	Overall
2.5"	Q414E	2.5"	13"	18.5"

5" x 11" Oval

ID	Part #	ID	Body	Overall	ID	Part#	ID	Body	Overall
2.25"	Q523E	2.25"	19.5"	25"	3"	Q5264F	2.5"	19.5"	25"
2.5"	Q524E	2.5"	19.5"	25"	2"	Q532F	2"	22.5"	29"
					2.25"	Q533F	2.25"	22.5"	29"

POWER FLOW SERIES

Polished T-304 Stainless Steel. A true-performance muffler at a truly affordable price. Attractive on the outside-powerful on the inside.

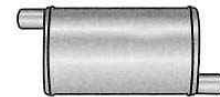

Inlet 2" PF9014-SS 2" Outlet
2.25" PF9004-SS 2.25"

STAINLESS STEEL
4.25" X 9.75" Oval 14" Body x 20" Overall

4" X 9" TURBO

OFFSET / CENTER
3 TUBE / 2 BAFFLE
WELDED NIPPLES
ALUMINIZED
DOUBLE WRAPPED

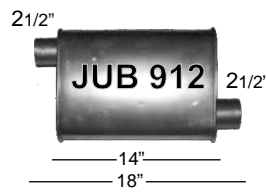
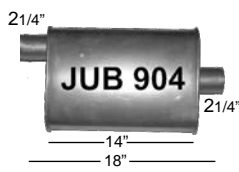



Full Boar Heavy Duty All-Welded Aluminized Mufflers

ROUND SUPER DUTY MUFFLERS

100% Aluminized • 100% Reversible Guaranteed • Performance NOT Affected

Numbering System

Series

F = Full Flow (straight through)
SD = Super Duty

Body Style

4 = 4" Case Dia. 7 = 7 Case Dia.
6 = 6" Case Dia. 8 = 8 Case Dia.

Body Length

12 = 12" Body 30 = 30" Body
18 = 18" Body
26 = 26.5" Body

Neck Diameter (measured at ID)

1 = 1.75" 5 = 2.75"
2 = 2" 6 = 3"
3 = 2.25" 7 = 3.5"
4 = 2.5 8 = 4"

Sample Part #: **SD 7 26 6 4 C**

Neck Configurations

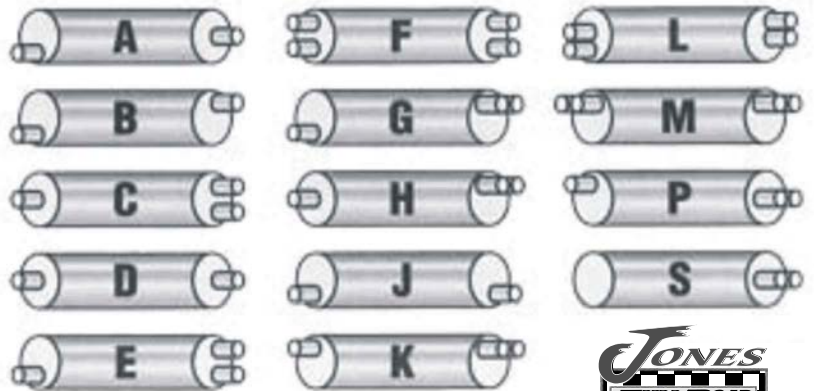

Round Mufflers					
Part #	Body Style	ID	ID	Body Length	Overall
MH150	4"	1.5"	1.5"	18"	21"
SD412-3D	4"	2.25"	2.25"	12"	18"
SD614-2D	6"	2"	2"	14"	20"
SD614-3D	6"	2.25"	2.25"	14"	20"
SD626-23B	6"	2"	2.25"	26.5"	33"
SD626-24B	6"	2"	2.5"	26.5"	33"
SD626-2B	6"	2"	2"	26.5"	33"
SD626-34B	6"	2.25"	2.5"	26.5"	33"
SD626-3B	6"	2.25"	2.25"	26.5"	33"
SD626-4B	6"	2.5"	2.5"	26.5"	33"
SD626-2D	6"	2"	2"	26.5"	33"
SD626-3D	6"	2.25"	2.25"	26.5"	33"
SD626-4D	6"	2.5"	2.5"	26.5"	33"
SD626-7D	6"	3.5"	3.5"	26.5"	33"
SD626-8D	6"	4"	4"	26.5"	33"
SD718-3B	7"	2.25"	2.25"	18"	24"
SD718-6B	7"	3"	3"	18"	24"
SD722-8D	7"	4"	4"	22"	28.5"
SD724-8D	7"	4"	4"	24"	30.5"
SD726-34B	7"	2.25"	2.5"	26.5"	33"
SD726-3B	7"	2.25"	2.25"	26.5"	33"
SD726-4B	7"	2.5"	2.5"	26.5"	33"

Round Mufflers					
Part #	Body Style	ID	ID	Body Length	Overall
SD726-6B	7"	3"	3"	26.5"	33"
SD726-64C	7"	3"	2.5"	26.5"	33"
SD726-4D	7"	2.5"	2.5"	26.5"	33"
SD726-6D	7"	3"	3"	26.5"	33"
SD726-7D	7"	3.5"	3.5"	26.5"	33"
SD726-8D	7"	4"	4"	26.5"	33"
SD726-3F	7"	2.25"	2.25"	26.5"	33"
SD726-4F	7"	2.5"	2.5"	26.5"	33"
SD726-32P	7"	2.25"	2"	26.5"	33"
SD726-4P	7"	2.5"	2.5"	26.5"	33"
SD726-64P	7"	3"	2.5"	26.5"	33"
SD730-35B	7"	2.25"	2.75"	30"	36"
SD824-4B	8"	2.5"	2.5"	24"	30"
SD824-78D	8"	3.5"	4"	24"	30"
SD826-68B	8"	3"	4"	26.5"	33"
SD830-6B	8"	3"	3"	30"	36"
SD830-7D	8"	3.5"	3.5"	30"	36"
SD830-8D	8"	4"	4"	30"	36"
SD830-64G	8"	3"	2.5"	30"	36"
SD830-54G	8"	2.75"	2.5"	30"	39.5"
SD830-54K	8"	2.75"	2.5"	30"	39.5"

Glasspack Mufflers

STOCK GLASSPACK MUFFLERS



30 Series (3" Case - 1.75" core, aluminized)

Aluminized Part #	Case Diameter	Case Length	Core Diameter	Overall Length	Neck Inlet	Neck Outlet	Neck Configuration	Package Quantity
A3009B	3"	9"	1.75"	9"			Blank	6
A3009S	3"	9"	1.75"	14"	1.75"	1.75"	Straight	6
A3012B	3"	12"	1.75"	12"			Blank	6
A3012S	3"	12"	1.75"	17"	1.75"	1.75"	Straight	6
A3012S-3	3"	12"	2"	17"	2"	2"	Straight	6
A3015B	3"	15"	1.75"	15"			Blank	6
A3015S	3"	15"	1.75"	20"	1.75"	1.75"	Straight	6
A3018B	3"	18"	1.75"	18"			Blank	6
A3018S	3"	18"	1.75"	23"	1.75"	1.75"	Straight	6
A3022B	3"	22"	1.75"	22"			Blank	6
A3022S	3"	22"	1.75"	27"	1.75"	1.75"	Straight	6
A3026B	3"	26"	1.75"	26"			Blank	6
A3026S	3"	26"	1.75"	31"	1.75"	1.75"	Straight	6

35 Series (3.5" case - 2" & 2.25" core, aluminized)

Aluminized Part#	Case Diameter	Case Length	Core Diameter	Overall Length	Neck Inlet	Neck Outlet	Neck Configuration	Package Quantity
A3509B	3.5"	9"	2.25"	9"			Blank	6
A3509S	3.5"	9"	2"	14"	2"	2"	Straight	6
A3509S-5	3.5"	9"	2.25"	14"	2.25"	2.25"	Straight	6
A3512B	3.5"	12"	2.25"	12"			Blank	6
A3512M	3.5"	12"	2.25"	17"	2"	2"	Medium	6
A3512S	3.5"	12"	2"	17"	2"	2"	Straight	6
A3512S-5	3.5"	12"	2.25"	17"	2.25"	2.25"	Straight	6
A3514B	3.5"	14"	2.25"	14"			Blank	6
A3514S	3.5"	14"	2"	19"	2"	2"	Straight	6
A3516B	3.5"	16"	2.25"	16"			Blank	6
A3516M	3.5"	16"	2.25"	21"	2"	2"	Medium	6
A3516M-5	3.5"	16"	2.25"	21"	2.25"	2.25"	Medium	6
A3516S	3.5"	16"	2"	21"	2"	2"	Straight	6
A3516S-5	3.5"	16"	2.25"	21"	2.25"	2.25"	Straight	6
A3518B	3.5"	18"	2.25"	18"			Blank	6
A3518F	3.5"	18"	2.25"	23"	2"	2"	Full	6
A3518F-5	3.5"	18"	2.25"	23"	2.25"	2.25"	Full	6
A3518M	3.5"	18"	2.25"	23"	2"	2"	Medium	6
A3518M-5	3.5"	18"	2.25"	23"	2.25"	2.25"	Medium	6
A3518S	3.5"	18"	2"	23"	2"	2"	Straight	6
A3518S-5	3.5"	18"	2.25"	23"	2.25"	2.25"	Straight	6
A3518S-8	3.5"	18"	2.25"	23"	2.5"	2.5"	Straight	6
A3520B	3.5"	20"	2.25"	20"			Blank	6
A3520S	3.5"	20"	2"	25"	2"	2"	Straight	6

(Continued)



Glasspack Mufflers

STOCK GLASSPACK MUFFLERS



35 Series (3.5" case - 2" & 2.25" core, aluminized)

Aluminized Part#	Case Diameter	Case Length	Core Diameter	Overall Length	Neck Inlet	Neck Outlet	Neck Configuration	Package Quantity
A3520S-5	3.5"	20"	2.25"	25"	2.25"	2.25"	Straight	6
A3522B	3.5"	22"	2.25"	22"			Blank	6
A3522F	3.5"	22"	2.25"	27"	2"	2"	Full	6
A3522M	3.5"	22"	2.25"	27"	2"	2"	Medium	6
A3522S	3.5"	22"	2"	27"	2"	2"	Straight	6
A3522S-5	3.5"	22"	2.25"	27"	2.25"	2.25"	Straight	6
A3524B	3.5"	24"	2.25"	24"			Blank	6
A3524M	3.5"	24"	2.25"	29"	2"	2"	Medium	6
A3524S	3.5"	24"	2"	29"	2"	2"	Straight	6
A3524S-5	3.5"	24"	2.25"	29"	2.25"	2.25"	Straight	6
A3524S-8	3.5"	24"	2.25"	29"	2.5"	2.5"	Straight	6
A3526B	3.5"	26"	2.25"	26"			Blank	6
A3526M	3.5"	26"	2.25"	31"	2"	2"	Medium	6
A3526S	3.5"	26"	2"	31"	2"	2"	Straight	6
A3530B	3.5"	30"	2.25"	30"			Blank	6
A3530S	3.5"	30"	2"	35"	2"	2"	Straight	6
A3530S-5	3.5"	30"	2.25"	35"	2.25"	2.25"	Straight	6
A3536B	3.5"	36"	2.25"	36"			Blank	6
A3536S	3.5"	36"	2"	41"	2"	2"	Straight	6
A3540B	3.5"	40"	2.25"	40"			Blank	6
A3540S	3.5"	40"	2"	45"	2"	2"	Straight	6

40 Series (4" case - 2.25" core, aluminized)

Aluminized Part #	Case Diameter	Case Length	Core Diameter	Overall Length	Neck Inlet	Neck Outlet	Neck Configuration	Package Quantity
A4012B	4"	12"	2.25"	12"			Blank	4
A4012S	4"	12"	2.25"	17"	2.25"	2.25"	Straight	4
A4015B	4"	15"	2.25"	15"			Blank	4
A4015S	4"	15"	2.25"	20"	2.25"	2.25"	Straight	4
A4018B	4"	18"	2.25"	18"			Blank	4
A4018F	4"	18"	2.25"	23"	2.25"	2.25"	Full	4
A4018M	4"	18"	2.25"	23"	2.25"	2.25"	Medium	4
A4018S	4"	18"	2.25"	23"	2.25"	2.25"	Straight	4
A4020B	4"	20"	2.25"	20"			Blank	4
A4020S	4"	20"	2.25"	25"	2.25"	2.25"	Straight	4

Nipple Size Ordering Chart	
All Nipples are "ID" Inside Diameter	
3	= 2" x 2"
4	= 2-1/4" x 2"
5	= 2-1/4" x 2-1/4"
6	= 2-1/2" x 2"
7	= 2-1/2" x 2-1/4"
8	= 2-1/2" x 2-1/2"
9	= 3" x 3"

Suffix Codes for Ordering Information	
B	= Blanks
S	= Straight Necks
MO	= Mild Offset Necks
FO	= Full Offset Necks

Glasspack Mufflers

STOCK GLASSPACK MUFFLERS



40 Series (4" case - 2.25" core, aluminized)

Aluminized Part #	Case Diameter	Case Length	Core Diameter	Overall Length	Neck Inlet	Neck Outlet	Neck Configuration	Package Quantity
A4022B	4"	22"	2.25"	22"			Blank	4
A4022S	4"	22"	2.25"	27"	2.25"	2.25"	Straight	4
A4024B	4"	24"	2.25"	24"			Blank	4
A4024S	4"	24"	2.25"	29"	2.25"	2.25"	Straight	4
A4026B	4"	26"	2.25"	26"			Blank	4
A4026S	4"	26"	2.25"	31"	2.25"	2.25"	Straight	4
A4030B	4"	30"	2.25"	30"			Blank	4
A4030S	4"	30"	2.25"	35"	2.25"	2.25"	Straight	4
A4036B	4"	36"	2.25"	36"			Blank	4
A4036S	4"	36"	2.25"	41"	2.25"	2.25"	Straight	4
A4040B	4"	40"	2.25"	40"			Blank	4
A4040S	4"	40"	2.25"	45"	2.25"	2.25"	Straight	4

45 Series (4" case - 2.5" core, aluminized)

Aluminized Part #	Case Diameter	Case Length	Core Diameter	Overall Length	Neck Inlet	Neck Outlet	Neck Configuration	Package Quantity
A4512B	4"	12"	2.5"	12"			Blank	4
A4512S	4"	12"	2.5"	17"	2.5"	2.5"	Straight	4
A4515B	4"	15"	2.5"	15"			Blank	4
A4515S	4"	15"	2.5"	20"	2.5"	2.5"	Straight	4
A4518B	4"	18"	2.5"	18"			Blank	4
A4518S	4"	18"	2.5"	23"	2.5"	2.5"	Straight	4
A4520B	4"	20"	2.5"	20"			Blank	4
A4520S	4"	20"	2.5"	25"	2.5"	2.5"	Straight	4
A4522B	4"	22"	2.5"	22"			Blank	4
A4522S	4"	22"	2.5"	27"	2.5"	2.5"	Straight	4
A4524B	4"	24"	2.5"	24"			Blank	4
A4524S	4"	24"	2.5"	29"	2.5"	2.5"	Straight	4
A4526B	4"	26"	2.5"	26"			Blank	4
A4526S	4"	26"	2.5"	31"	2.5"	2.5"	Straight	4
A4530B	4"	30"	2.5"	30"			Blank	4
A4530S	4"	30"	2.5"	35"	2.5"	2.5"	Straight	4
A4536B	4"	36"	2.5"	36"			Blank	4
A4536S	4"	36"	2.5"	41"	2.5"	2.5"	Straight	4
A4540B	4"	40"	2.5"	40"			Blank	4
A4540S	4"	40"	2.5"	45"	2.5"	2.5"	Straight	4

Nipple Size Ordering Chart

All Nipples are "ID" Inside Diameter

3	= 2" x 2"
4	= 2-1/4" x 2"
5	= 2-1/4" x 2-1/4"
6	= 2-1/2" x 2"
7	= 2-1/2" x 2-1/4"
8	= 2-1/2" x 2-1/2"
9	= 3" x 3"

Suffix Codes for Ordering Information

B = Blanks
 S = Straight Necks
 MO = Mild Offset Necks
 FO = Full Offset Necks



Glasspack Mufflers

STOCK GLASSPACK MUFFLERS



43 Series (4" case - 3" core, aluminized)

Aluminized Part #	Case Diameter	Case Length	Core Diameter	Overall Length	Neck Inlet	Neck Outlet	Neck Configuration	Package Quantity
A4312B	4"	12"	3"	12"			Blank	4
A4312S	4"	12"	3"	17"	3"	3"	Straight	4
A4315B	4"	15"	3"	15"			Blank	4
A4315S	4"	15"	3"	20"	3"	3"	Straight	4
A4318B	4"	18"	3"	18"			Blank	4
A4318S	4"	18"	3"	23"	3"	3"	Straight	4
A4322B	4"	22"	3"	22"			Blank	4
A4322S	4"	22"	3"	27"	3"	3"	Straight	4
A4322S-8	4"	22"	3"	27"	2.5"	2.5"	Straight	4
A4324B	4"	24"	3"	24"			Blank	4
A4324S	4"	24"	3"	29"	3"	3"	Straight	4
A4330B	4"	30"	3"	30"			Blank	4
A4330S	4"	30"	3"	35"	3"	3"	Straight	4

50 Series (5" case - 3" core, aluminized)

Aluminized Part #	Case Diameter	Case Length	Core Diameter	Overall Length	Neck Inlet	Neck Outlet	Neck Configuration	Package Quantity
A5018B	5"	18"	3"	18"			Blank	2
A5018B-350	5"	18"	3.5"*	18"			Blank	1
A5018B-400	5"	18"	4"*	18"			Blank	1
A5018S	5"	18"	3"	23"	3"	3"	Straight	2
A5022B	5"	22"	3"	22"			Blank	2
A5022S	5"	22"	3"	27"	3"	3"	Straight	2
A5024B	5"	24"	3"	24"			Blank	2
A5024B-350	5"	24"	3.5"*	24"			Blank	1
A5024B-400	5"	24"	4"*	24"			Blank	1
A5024S	5"	24"	3"	29"	3"	3"	Straight	2
A5026B	5"	26"	3"	26"			Blank	2
A5026S	5"	26"	3"	31"	3"	3"	Straight	2
A5030B	5"	30"	3"	30"			Blank	2
A5030S	5"	30"	3"	35"	3"	3"	Straight	2

* Now Available in 3.5" & 4" Cores!



35 Series Specialty (header & twin)

Aluminized Part #	Case Diameter	Case Length	Core Diameter	Overall Length	Neck Inlet	Neck Outlet	Neck Configuration	Package Quantity
ADS200	3.5"	18"	2.5"	36"	2.5"	2"	Twin Combo	1
AH18	3.5"	18"	2.25"	25"	3", 3-Hole	2"	3-Hole Header	1
AH18A	3.5"	18"	2.25"	25"	3", 3-Hole	2.25"	3-Hole Header	1

Glasspack Mufflers

STOCK TORPEDO PACK MUFFLERS



Blank Torpedo Pack



Torpedo Pack w/Neck

Torpedo Glasspacks (Dual Outlet)								
Aluminized Part #	Case Diameter	Case Length	Core Diameter	Overall Length	Neck Inlet	Neck Outlet	Neck Configuration	Package Quantity
APP4315-9-5	4"	15"	3"	33"	3"	2.25"	Dual Outlet	1
APP4315-9-8	4"	15"	3"	33"	3"	2.5"	Dual Outlet	1
APP4315-B-5	4"	15"	3"	30"	Blank	2.25"	Dual Outlet	1
APP4315-B-8	4"	15"	3"	30"	Blank	2.5"	Dual Outlet	1
APP4318-9-5	4"	18"	3"	36"	3"	2.25"	Dual Outlet	1
APP4318-9-8	4"	18"	3"	36"	3"	2.5"	Dual Outlet	1
APP4318-B-5	4"	18"	3"	33"	Blank	2.25"	Dual Outlet	1
APP4318-B-8	4"	18"	3"	33"	Blank	2.5"	Dual Outlet	1
APP4515-234-5	4"	15"	2.5"	33"	2.75"	2.25"	Dual Outlet	1
APP4515-234-8	4"	15"	2.5"	33"	2.75"	2.5"	Dual Outlet	1
APP4515-5-5	4"	15"	2.5"	33"	2.25"	2.25"	Dual Outlet	1
APP4515-8-5	4"	15"	2.5"	33"	2.5"	2.25"	Dual Outlet	1
APP4515-8-8	4"	15"	2.5"	33"	2.5"	2.5"	Dual Outlet	1
APP4515-9-5	4"	15"	2.5"	33"	3"	2.25"	Dual Outlet	1
APP4515-B-5	4"	15"	2.5"	30"	Blank	2.25"	Dual Outlet	1
APP4515-B-8	4"	15"	2.5"	30"	Blank	2.5"	Dual Outlet	1
APP4518-8-5	4"	18"	2.5"	36"	2.5"	2.25"	Dual Outlet	1
APP4518-8-8	4"	18"	2.5"	36"	2.5"	2.5"	Dual Outlet	1

Turbo Tube Mufflers & Welded Resonators

AR SERIES - ALUMINIZED WELDED RESONATORS

See Page 15 for Nipple Size and Suffix Chart



Blank



Straight



With Downspout

Aluminized Welded Resonators								
Aluminized Part #	Case Diameter	Case Length	Core Diameter	Overall Length	Neck Inlet	Neck Outlet	Neck Configuration	Package Quantity
AR3012B	3"	12"	1.75"	12"			Blank	6
AR3012S	3"	12"	1.75"	17"	1.75"	1.75"	Straight	6
AR3012S-3	3"	12"	2"	17"	2"	2"	Straight	6
AR3012S-5	3"	12"	2.25"	17"	2.25"	2.25"	Straight	6
AR3014B	3"	14"	1.75"	14"			Blank	6
AR3014S	3"	14"	1.75"	19"	1.75"	1.75"	Straight	6
AR3514B	3.5"	14"	2.25"	14"			Blank	6
AR3514S	3.5"	14"	2"	19"	2"	2"	Straight	6
AR200	3.5"	16"	2"	30"	2"	2"	With Downspout	1
AR225	3.5"	16"	2.25"	30"	2.25"	2.25"	With Downspout	1
AR4011S-3	4"	11"	2"	16"	2"	2"	Straight	1
AR4016S	4"	16"	2.25"	23"	2.25"	2.25"	Straight	1
AR4016S-3	4"	16"	2"	23"	2"	2"	Straight	1



Turbo Tube Mufflers & Welded Resonators

TURBO TUBE MUFFLERS



Aluminized
Reversible Guaranteed
Performance Not Affected

See Page 15 for Nipple
Size and Suffix Chart



4" Twin Turbo Tube Mufflers

Aluminized Part #	Case Diameter	Case Length	Core Diameter	Overall Length	Neck Inlet	Neck Outlet	Neck Configuration	Package Quantity
ATT12B	4"	12"	1.75" (2)	12"				4
ATT12S-1	4"	12"	1.75" (2)	18"	1.75"	1.75"	Straight	4
ATT12S-3	4"	12"	1.75" (2)	18"	2"	2"	Straight	4
ATT12S-5	4"	12"	1.75"	18"	2.25"	2.25"	Straight	4
ATT15B	4"	15"	1.75"	15"			Blank	4
ATT15F-3	4"	15"	1.75"	21"	2"	2"	Full	4
ATT15F-5	4"	15"	1.75"	21"	2.25"	2.25"	Full	4
ATT15M-3	4"	15"	1.75"	21"	2"	2"	Medium	4
ATT15M-5	4"	15"	1.75"	21"	2.25"	2.25"	Medium	4
ATT15S-1	4"	15"	1.75"	21"	1.75"	1.75"	Straight	4
ATT15S-3	4"	15"	1.75"	21"	2"	2"	Straight	4
ATT15S-4	4"	15"	1.75"	21"	2.25"	2"	Straight	4
ATT15S-5	4"	15"	1.75"	21"	2.25"	2.25"	Straight	4
ATT15S-8	4"	15"	1.75"	21"	2.5"	2.5"	Straight	4
ATT18B	4"	18"	1.75"	18"			Blank	4
ATT18F-3	4"	18"	1.75"	24"	2"	2"	Full	4
ATT18M-3	4"	18"	1.75"	24"	2"	2"	Medium	4
ATT18M-5	4"	18"	1.75"	24"	2.25"	2.25"	Medium	4
ATT18S-1	4"	18"	1.75"	24"	1.75"	1.75"	Straight	4
ATT18S-3	4"	18"	1.75"	24"	2"	2"	Straight	4
ATT18S-3-5U	4"	18"	1.75"	31"	2"	2.25"	Dual Outlet	1
ATT18S-4	4"	18"	1.75"	24"	2.25"	2"	Straight	4
ATT18S-5	4"	18"	1.75"	24"	2.25"	2.25"	Straight	4
ATT18S-8	4"	18"	1.75"	24"	2.5"	2.5"	Straight	4
ATT22B	4"	22"	1.75"	22"			Blank	4
ATT22S-3	4"	22"	1.75"	28"	2"	2"	Straight	4
ATT22S-5	4"	22"	1.75"	28"	2.25"	2.25"	Straight	4
ATT24B	4"	24"	1.75"	24"			Blank	4
ATT24S-3	4"	24"	1.75"	30"	2"	2"	Straight	4
ATT24S-5	4"	24"	1.75"	30"	2.25"	2.25"	Straight	4
ATT24S-8	4"	24"	1.75"	30"	2.5"	2.5"	Straight	4

5" Twin Turbo Tube Mufflers

Aluminized Part #	Case Diameter	Case Length	Core Diameter	Overall Length	Neck Inlet	Neck Outlet	Neck Configuration	Package Quantity
ATT5018B	5"	18"	2.25"	18"			Blank	2
ATT5018S-8	5"	18"	2.25"	24"	2.5"	2.5"	Straight	2
ATT5018S-8-5U	5"	18"	2.25"	31"	2.5"	2.25"	Dual Outlet	1
ATT5018S-9	5"	18"	2.25"	24"	3"	3"	Straight	2
ATT5018S-9-5U	5"	18"	2.25"	31"	3"	2.25"	Dual Outlet	1
ATT5024B	5"	24"	2.25"	24"	2.5"	2.5"	Blank	2
ATT5024S-8	5"	24"	2.25"	30"			Straight	2
ATT5024S-9	5"	24"	2.25"	30"	3"	3"	Straight	2
ATT5024S-9-5U	5"	24"	2.25"	37"	3"	2.25"	Dual Outlet	1

Specialty Performance Exhaust Products



UNIVERSAL "U" & "X" PIPES



- Custom "U" pipes convert single outlet muffler for a quick & easy dual tailpipe installation!

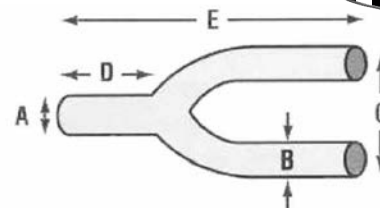

"U" Pipes - 16 gauge					
Part #	A Single Inlet Diameter (ID)	B Dual Inlet Diameter (OD)	C Center Line	D Inlet Neck Length	E Overall Length
U1-1	1.75"	1.75"	6"	3.75"	14"
U2-2	2"	2"	6"	3.75"	14"
U3-2	2.25"	2"	6"	3.75"	14"
U3-3	2.25"	2.25"	6"	3.75"	14"
U4-3	2.5"	2.25"	6"	3.75"	14"
U4-4	2.5"	2.5"	6"	3.75"	14"
U6-3	3"	2.25"	6"	3.75"	14"
U6-4	3"	2.5"	6"	3.75"	14"
U6-6	3"	3"	6"	3.75"	16.75"

**Increased Power & Torque • Equalized Back Pressure Pulses • Maximum Scavenging of Spent Exhaust Gases
Reduced Interior Resonance • Compact Design for Ease of Installation**

- Add an "X" pipe to dual exhausts to help equalize the pressure between both banks of the engine.
- With increase torque throughout the RPM range, eliminating back pressure, mellowing the tone both inside & outside the vehicle.

"X" Pipes - 16 gauge		
Part #	A Diameter ID	B Overall Length
XP2	2"	9.25"
XP3	2.25"	9.75"
XP4	2.5"	10"
XP6	3"	11"
XP7	3.5"	12.5"
XP8	4"	13"
XP4*	2.5"	N/A
XP6*	3"	N/A

* Universal X-Pipe Installation Kits

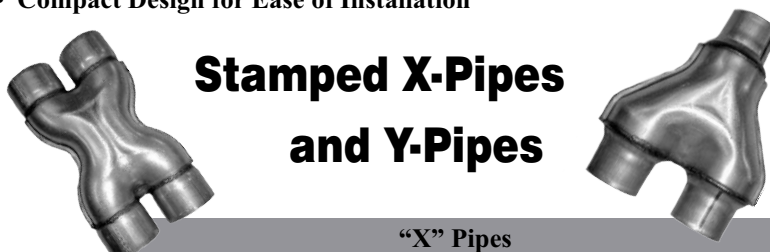

Stamped X-Pipes and Y-Pipes

"X" Pipes			
Part #	Dual Diameter (ID)	Center Line	Overall Length
SXP2SS	2"	4"	15"
SXP3	2.25"	4"	15"
SXP3SS	2.25"	4"	15"
SXP4	2.5"	4"	15"
SXP4SS	2.5"	4"	15"
SXP6	3"	4"	14.5"
SXP6SS	3"	4"	14.5"

"Y" Pipes			
Part #	Dual Diameter (ID)	Center Line	Overall Length
SU2-2	2"	4"	10"
SU2-2SS	2"	4"	10"
SU3-3	2.25"	4"	10"
SU3-3	2.25"	4"	10"
SU3-3SS	2.25"	4"	10"
SU4-3	2.5" X 2.25"	4"	10"
SU4-3SS	2.5" X 2.25"	4"	10"
SU4-4	2.5"	4"	10"
SU4-4SS	2.5"	4"	10"
SU6-3	3" X 2.5"	4"	10"
SU6-3SS	3" X 2.5"	4"	10"
SU6-4	3" X 2.5"	4"	10"
SU6-4SS	3" X 2.5"	4"	10"
SU6-6	3" X 3"	4"	10"
SU6-6SS	3" X 3"	4"	10"

SWINGING HANGER



PART NUMBER	DIMENSION	BEND ANGLE
JSH3845	3/8" ROD	45 DEGREE BEND
JSH3890	3/8" ROD	90 DEGREE BEND
JSH51645	5/16" ROD	45 DEGREE BEND
JSH51690	5/16" ROD	90 DEGREE BEND
JSH3890AH	3/8" ROD	ARROW HEAD

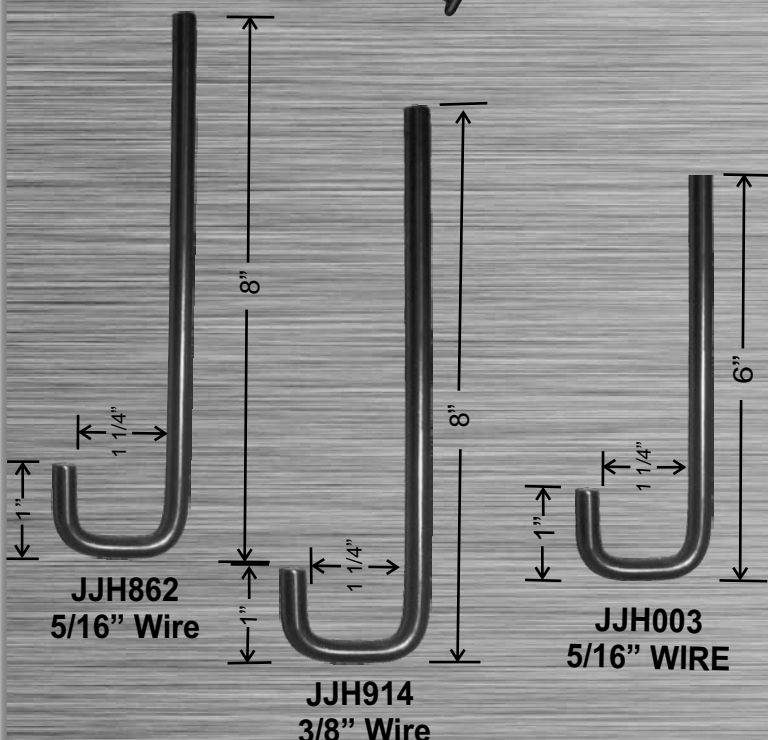
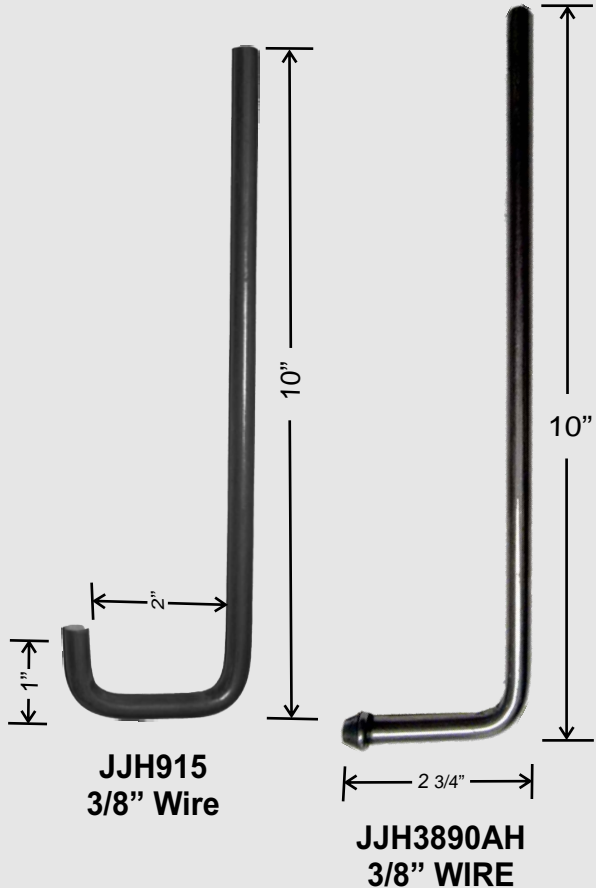
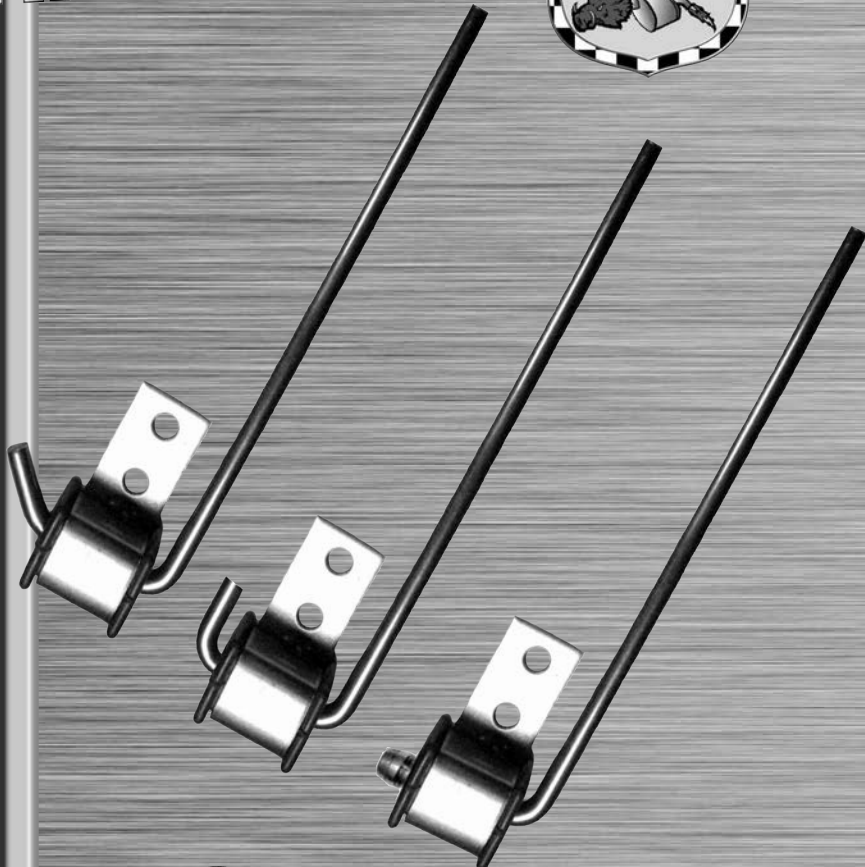

WIRE HANGER

Specialty Performance Exhaust Products

FLEX TUBES



Expandable Aluminized Necks • 2-Ply 16 Gauge, Stainless Steel Wire Braid

- No leak, automated welding of necks
- Stainless 2-ply bellows construction for maximum lateral compression
- Internal Braid for increased life
- Hydroforming process ensures leak free bellows

Flex Tube "Blanks" (For Weld Only)			
Part #	Description (ID)	Body Length	Overall Length
FLX1344B	1.75"	4"	4"
FLX1346B	1.75"	6"	6"
FLX1348B	1.75"	8"	8"
FLX13410B	1.75"	10"	10"
FLX2004B	2"	4"	4"
FLX2006B	2"	6"	6"
FLX2008B	2"	8"	8"
FLX2010B	2"	10"	10"
FLX21408B	2.25"	8"	8"
FLX21410B	2.25"	10"	10"
FLX2144B	2.25"	4"	4"
FLX2146B	2.25"	6"	6"
FLX2508B	2.5"	8"	8"
FLX2510B	2.5"	10"	10"
FLX2506B	2.5"	6"	6"
FLX2504B	2.5"	4"	4"
FLX3004B	3"	4"	4"
FLX3006B	3"	6"	6"
FLX3008B	3"	8"	8"
FLX3010B	3"	10"	10"
FLX3012B	3"	12"	12"
FLX3014B	3"	14"	14"
FLX4010B	4"	10"	10"

Flex Tube with Neck			
Part #	Description (ID)	Body Length	Overall Length
FLX1344N	1.75"	4"	8"
FLX1346N	1.75"	6"	10"
FLX1348N	1.75"	8"	12"
FLX13410N	1.75"	10"	14"
FLX2004N	2"	4"	8"
FLX2006N	2"	6"	10"
FLX2008N	2"	8"	12"
FLX2010N	2"	10"	14"
FLX21408N	2.25"	8"	12"
FLX21410N	2.25"	10"	14"
FLX2144N	2.25"	4"	8"
FLX2146N	2.25"	6"	10"
FLX2508N	2.5"	8"	12"
FLX2510N	2.5"	10"	14"
FLX2506N	2.5"	6"	10"
FLX2504N	2.5"	4"	8"
FLX3006N	3"	6"	10"
FLX3004N	3"	4"	12"
FLX3008N	3"	8"	12"
FLX3010N	3"	10"	14"
FLX3012N	3"	12"	16"
FLX3014N	3"	14"	18"
FLX4010N	4"	10"	14"





Specialty Performance Exhaust Products

HEADER BUDDY, HEADER COLLECTORS & CONNECTORS

HEADER BUDDY™ Is An Innovative, New Design For Header/Exhaust Assembly That Requires NO GASKET!



Header Buddy		
Part #	Inlet (OD)	Outlet (OD)
AHB1	3"	2.5"
AHB2	3"	2.25"
AHB3	3"	3"

- **NO MORE** time & money spent at exhaust centers!
- **NO MORE** crawling under your car to replace gaskets!
- **NO MORE** gasket repairs!

Header Buddy is made of 16 gauge aluminized tubing and has an inlet OD that fits 3" collector boxes, with an outlet of 2.5" OD. Flanges are 5/16 thick. Sold in pairs.

Do not over-tighten when installing.

FAQ's About Header Buddy:

- Q.** Do I have to alter my headers? **No.**
- Q.** What does this product do for me? **Allows you to eliminate the collector gasket from the exhaust system.**
- Q.** What do I do with the old gaskets? **Landfill property. Remember, NO GASKETS.**
- Q.** Can I disconnect the headers from the exhaust system after this product is installed? **Yes. The Header Buddy is reusable.**
- As a matter of fact, many drag racers use this product because of the ease of disconnecting the exhaust system during races.**



Header Collectors (6 piece set)				
Part #	Set Includes	Inlet Size (ID)	# Per Box	Overall Length
AHC1	Outlet Collectors	2.5"	2	7"
	3-Hole Flanges	-	2	3"
	3-Hole Gaskets	-	2	3"

Welded Aluminize Header Connectors				
Part #	Set Includes	Inlet Size (ID)	# Per Box	Overall Length
AWHC212	2.5"	2.5"	1	5"
AWHC300	3"	2.25"	1	5"
AWHC312	3.5"	2.5"	1	5"

* All Flanges are 3 hole.



BearPaw Hand Cleaner, it's tough enough to clean virtually everything that shop hands come in contact with, it's gentle enough to use daily without drying and cracking skin, and it won't clog the plumbing. BearPaw is a concentrated non-toxic detergent-based cleaner; you will be amazed how little is needed to do the Job! Many other cleaners use petroleum, which can leave your hands slimy and cause potential plumbing issues. We are offering five different sizes ranging from a pint to a five gallon pail, to suit everyone's needs.

Part #	Description
JBP16	Pt. Container
JBP32	Qt. Container
JBP64	½ Gal. Container
JBP128	Gal. Container
JBP5GAL	5 Gallon Pail



DIRECT FLEX



*** Gasket Included**



JGM1342L-3BF

98-00 Chevrolet S-10 2.2L
98-00 GMC S-15 Sonoma 2.2L



JGM1342L-4BF

96-99 Pontiac Grand Am A/M DOHC 2.4L,
96-99 Pontiac Sunfire 2.4L,
97-98 Chevrolet Malibu 4 cyl 2.4L,
98 Chevrolet Malibu 6-cyl 3.2L
96-98 Buick Skylark A/M DOHC 2.4L
96-98 Chevrolet Cavalier 2.4L
96-98 Oldsmobile Achieva A/M DOHC 2.4L



JGM2143L-2BF

97-04 Chevrolet Monte Carlo 3.4L
99-03 Chevrolet Malibu 3.1L
97-00 Chevrolet Venture 3.4L
00-04 Chevrolet Impala 3.4L,
97-04 Buick Century 3.1L
97-98 Buick Regal 3.1L,
97-00 Oldsmobile Silhouette 3.4L
97-04 Pontiac Grand Prix 3.1L
97-00 Pontiac Montana/Transport 3.4L



JGM2143L-3BF

99-02 Chevrolet Cavalier 2.4L
99 Malibu 2.4L,
99-01 Oldsmobile Alero VIN T 2.4L
02-04 Oldsmobile Alero VIN F 2.2L
1999 Pontiac Grand Design #2 2.4L,
99-01 Pontiac Grand Am SE VIN T 2.4L
02-04 Pontiac Grand Am VIN F 2.2L,
99-02 Pontiac Sunfire 2.2L



JGM1342L-2BF

96-97 Chevrolet S-10 2.2L
96-97 GMC S-15 Sonoma 2.2L
96-97 Isuzu Hombre 2.2L



JGM2143L-3LBF

98-99 Chevrolet Monte Carlo 3.8L
99-05 Chevrolet Cavalier Exc. Code 4 2.2L
05-08 Chevrolet Cobalt 2.2L
06-07 Chevrolet Cobalt 2.4L
06-07 Chevrolet HHR 2.2L, 2.4L
07 Pontiac G5 2.2L, 2.4L,
05-07 Saturn Ion 1, 2, 3 2.2L
05-07 Saturn Ion 3 2.4L



JGM2123L-2BF

97-01 Chevrolet Lumina 3.1L
01 Chevrolet Impala 3.4L,
97-99 Chevrolet Monte Carlo 3.0L
1997 Oldsmobile Cutlass Supreme 3.1L



JFC2128L-3BF

95-00 Ford Contour V6 w/AT 2.5L,
95-00 Mercury Mystique V6 w/AT 2.5L



JDS2123L-4BF

95-00 Dodge Stratus 2.0L, 2.4L, 2.5L
98-00 Plymouth Breeze 2.0L
97-00 Plymouth Neon 2.0L
95-00 Chrysler Sebring 2.4L, 2.5L
96-97 Chrysler Cirrus 2.4L
95-98 Chrysler Cirrus LT 2.5L
01-07 PT Cruiser Turbo 2.4L,

96-00 Dodge Caravan/Grand Caravan 2.4L
96-01 Dodge Caravan/Grand Caravan 3.3L
96-01 Dodge Caravan 3.8L,
96-00 Dodge Grand Caravan 3.8L
96-00 Plymouth Voyager/Grand Voyager 2.4L
96-01 Plymouth Voyager 3.3L, 3.8L,
96-00 Plymouth Grand Voyager 3.3L, 3.8L
96-00 Chrysler Town & Country 3.3L, 3.8L

DIRECT FLEX



* Gasket Included



JFT2004L-2BF

00-05 Ford Taurus DOHC VIN S 3.0L,
00-07 Ford Taurus DOHC VIN U 3.0L,
00-05 Mercury Sable DOHC VIN S 3.0L,
00-07 Mercury Sable VIN U 3.0L



JGM21242L-2BF

98-99 Oldsmobile Intrigue K engine 3.8L,
99-02 Oldsmobile Intrigue 3.5L,
97-03 Pontiac Grand Prix 3.8L



JIMP1342L-6BF

98-00 Volkswagen 2.0L



JVW2123L-4BF

06-08 Volkswagen Jetta



JGM2126L-BB-3BFL

Chevrolet Big Block-Left Side



JGM2126L-BB-2BR

Chevrolet Big Block-Right Side



JGM2143L-3LBF-C

02-05 Chevrolet Cobalt DOHC VIN F 2.2L,
05-08 Chevrolet Cobalt DOHC VIN F 2.2L,
05-08 Chevrolet Cobalt VIN B 2.4L,
06-08 Chevrolet HHR DOHC 2.2L, 2.4L,
06-08 Pontiac G5 DOHC 2.2L,
07-08 Pontiac G5 DOHC 2.4L



JPGP2343L-2BF

97-04 Buick Regal 3.8L,
00-05 Chevrolet Impala K engine 3.8L,
04-05 Chevrolet Impala Supercharged 3.8L,
99 Chevrolet Lumina VIN K 3.8L,
00-05 Chevrolet Monte Carlo K engine 3.8L,
04-05 Chevrolet Monte Carlo Supercharged 3.8L,
97-03 Pontiac Grand Prix 3.8L,
99 Pontiac GTP Supercharged 3.8L,
98-99 Oldsmobile Intrigue K engine 3.8L,
99-02 Oldsmobile Intrigue 3.5L



JGM2134L-3LBF-CO2

02 - 08 Chevrolet Cobalt Auto Tran 4 Cyl. 2.2L, 2.4L
02 - 09 Chevrolet HHR 4 Cyl. 2.2L, 2.4L
06 - 09 Saturn Ion 4Cyl. 2.4L
05 - 07 Saturn Ion 1,2,3, - 4 Cyl. 2.2L



JDC2123L-4BF

1996 - 99 Chrysler
Town & Country
Dodge Caravan
Plymouth Voyager 3.0L



Slip-On Mufflers For

Harley Davidson® Softail®, Touring® Dyna Glide® & Sportster® Models Motorcycles



Angle Cut Fits All Touring Models 1995 - 2008

Touring® Model

JAC31230MC Slash Up,
JAC31230MCRV Down, Out

JAC31230MC-134
JAC31230MCRV-134
JAC31230MC-200
JAC31230MCRV-200
JAC31230MC-250
JAC31230MCRV-250

BAFFLE SIZES:
1 3/4", 2"
& 2 1/2"



*Baffles sold in pairs for Touring Models.

Straight Cut

Touring® Model

Fits All Touring Models 1995 - 2008

JPT31228MC JPT31228MC-200
JPT31230MC JPT31230MC-200
JPT31228MC-134 JPT31228MC-250
JPT31230MC-134 JPT31230MC-250

BAFFLE SIZES:
1 3/4", 2"
and 2 1/2"



BAFFLES-MCB134,
MCB200, MCB250

Angle Cut

Sportster® Model

Fits Sportster Models 2004 - 2008



JAC322MCSP Sportster Series 04'-08'

2" BAFFLES

Softail® Model

- Heritage-FLSTC
- Custom-FXSTC
- Night Train-FXSTB
- SoftailStandard-FXST
- Rocker C-FXCWC
- Rocker-FXCW

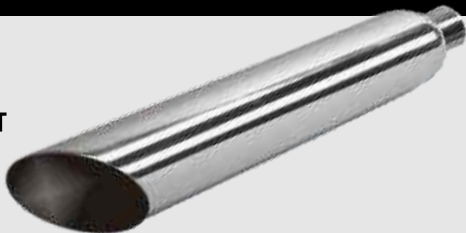

JAC322MC
*2" SoftTail® Baffle Included Fits Softail Models 2007 & 2008

Dyna-Glide® Model

Fits 1995-2008 Models:
Super Glide-FXD
35th Anniversary-FXD135
Wide Glide-FXDWG
Street Bob-FXDB
SuperGlide-FXDC
Screamin' Eagle-FXDSE
Dyna Lowrider-FXDL



*2" Dyna-Glide® Baffle Included **JAC320MCDG**

All slip-on mufflers come complete with mounting hardware for factory mounting locations. Muffler clamp not included.



Part No.	Fits Jones Models	Applications	Fitment	Qty	Length	Width	Wt.
MCT312AC	JPT31228MC	Angle Cut Style Exhaust Tip Extension Fit's 3.5" Straight Cut Pipes pre-drilled for aftermarket tips	All Touring models 95' thru 09'	Pair	6.75"	3.5"	1lb.
	JPT31228MC134						
	JPT31228MC200						
	JPT31228MC250						
MCT312TD	JPT31228MC	Turn Down Style Exhaust Tip Extension Fit's 3.5" Straight Cut Pipes pre-drilled for aftermarket tips	All Touring models 95' thru 09'	Pair	8.5"	3.5"	1lb.
	JPT31228MC134						
	JPT31228MC200						
	JPT31228MC250						

Tests Prove Horsepower Boost and Performance

Full Boar mufflers have been engineered through thousands of hours of development and “real world” application in the performance division of Jones Exhaust Systems. We believe our motorcycle exhaust offers the best combination of performance, quality, sound and price in the market today. Our performance exhaust experience goes back 40 years to 1986. Our baffles are wrapped in high temperature fiberglass matting to disperse heat and retain sound. Our state-of-the-art hexavalent chrome plating process allows us to offer a two-year limited warranty against manufacturer defects. If you are looking for increased power and great sound at a great price, then Full Boar motorcycle mufflers are for you.

Based on the 2005 H-D Roadking dyno testing, there is a great boost in power. Full Boar Mufflers will make your bike sound the way a Harley® Should—deep and throaty. You will feel the “seat of the pants performance” as soon as you crank and ride the motorcycle

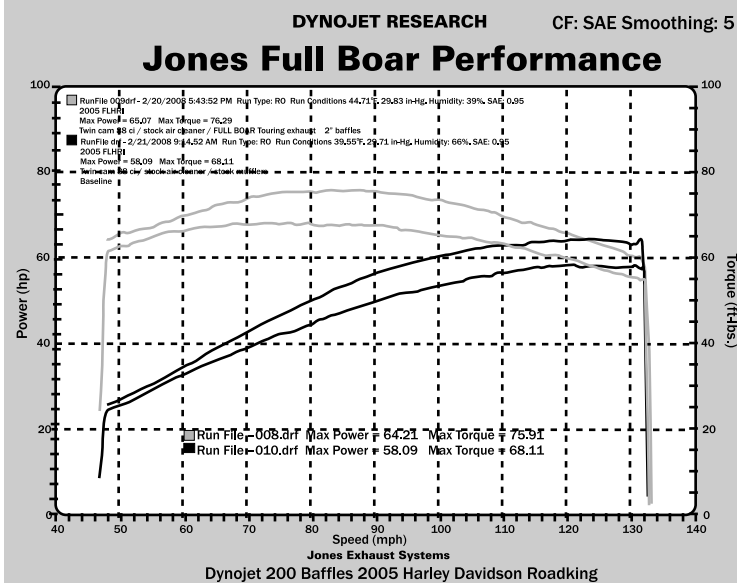
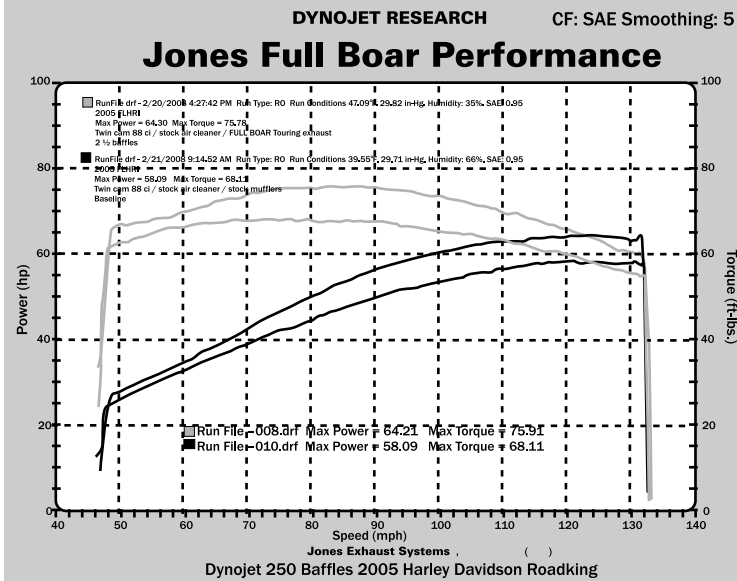
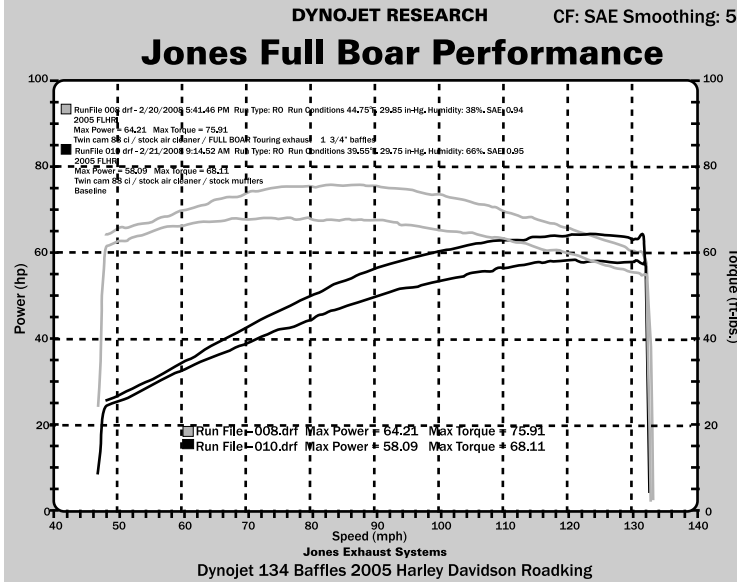

DYNO RESULTS FROM 2005 HARLEY DAVIDSON® ROADKING®:

Starting with Stock pipes, we ran the bike through the Dyno.
 Baseline with stock mufflers – no other modifications.
 58.09 Max Power – 68.11 Max Torque

Full Boar Mufflers with 1 3/4" baffles with no other modifications.
 64.21 Max Power = Gain of 6.12 Max Power
 75.91 Max Torque = Gain of 7.80 Max Torque

Full Boar Mufflers with 2.00" baffles with no other modifications.
 65.07 Max Power = Gain of 6.98 Max Power
 76.29 Max Torque = Gain of 8.11 Max Torque

Full Boar Mufflers with 2.50" baffles with no other modifications.
 Power = Gains of 6.21 Max Power
 75.78 Max Torque = Gain of 7.67 Max Torque

The mufflers and components offered may not meet EPA emission and noise guidelines and may be restricted to off-road only. Blueing may be caused by tuning characteristics, over-heating, cam timing, carburetor jetting, etc. and is not a manufacturing defect. The name Harley-Davidson®, and all models of motorcycles associated with the Harley-Davidson® name are trademarks of Harley Davidson®, and are utilized within this flyer and/or catalog.





JONES EXHAUST OFFERS A LINE OF STAINLESS STEEL TUBING, PRODUCED DOMESTICALLY. IT'S AVAILABLE IN BOTH 409 NON-POLISHED AND 304 HIGH-POLISHED IN 14 GAUGE.



PART NUMBER	DESCRIPTION
	10' NON-POLISHED
114175SSNP	1.75"
114200SSNP	2"
114225SSNP	2 1/4"
114250SSNP	2 1/2"
114300SSNP	3"
	10' HIGH-POLISHED
114200SSHP	2"
114225SSHP	2 1/4"
114250SSHP	2 1/2"
114300SSHP	3"

409, NON-POLISHED - 10' STICKS IN 2", 2 1/4", 2 1/2" AND 3"

304, HIGH POLISHED - 10' STICKS IN 2", 2 1/4", 2 1/2", AND 3"

PRIME CUTS

Bi-Metal Reciprocating Saw Blades

- Blade61014 6" Length, 10-14 teeth per inch .035 gage
 Blade81014 8" Length, 10-14 teeth per inch .049 gauge
 Blade814 8" Length, 14 teeth per inch .035 gauge

*All blades packed 10 blades per pack



3.0" Case Glasspacks	13
3.5" Case Glasspacks	13 - 14
4.0" Case Glasspacks	14 - 15
4.0" Case Turbo Tubes	16
5.0" Case Glasspacks	17
5.0" Case Turbo Tubes	17
6"-7"-8" Round All-Welded Mufflers	12
Aluminized Resonators	17
Black Vein Tips	6
Bear Paw Hand Cleaner	22
Chrome Angle Cut Tips	3
Chrome Chevelle Tips	1
Chrome Display Stand	3
Chrome Dual Tips	2
Chrome Foreign Car Tips	1
Chrome Inside Roll Angle Cut Tips	2
Chrome Inside Roll Pencil Tips	1
Chrome Pencil Tips	2
Chrome Resonated Tip.....	1
Chrome Specialty Tips	3
Chrome Truck Stacks	2
Chrome Turn Down Tips	2
Clamp-On (Necks) Flex Tubes	21
Custom "U" Dual Outlet Pipes	19
Direct Flex	23-24
Flow Deflector Directional Performance Mufflers	8
Full Boar Slip-on Motorcycle Mufflers	24 -25
Full Flow Large Body Oval Mufflers	9
Full Flow Large Body Round Mufflers	9
Generator Mufflers	11
Header Buddy Kits	22
Header Collectors	22
Max Flow Muffler	7
Midnight Pearl (Black Chrome) Tips	6
Quiet Tone Large Body Performance Mufflers	10
Prime Cuts Saw Blades.....	
Quite Tone Small Oval Performance Mufflers.....	10
Silver Vein Tips	6
Single Chamber Compact Race Mufflers	8
Specialty Glasspacks	16
Stainless Angle Cut Tips	5
Stainless Chevy Bowtie Tips	4
Stainless Inside Roll "Big Bore" Straight Cut Tips	5
Stainless Inside Roll Tips	5
Stainless Pencil Tips	4
Stainless Specialty Tips	4
Stainless Steel Tubing	26
Stainless Turn Down Tips	5
Stamped X and Y.....	19
Swinging Hangers	23
Torpedo Pack Dual Outlet Glasspacks	16
Universal "X" Pipe Installation Kits	18
Universal "X" Pipes	18
V-Power Performance Mufflers	10
Warranty Policy	Inside Front Cover
Weld-on (Blank) Flex Tubes	21
Welding Wire	10