



Model no.:	Stock no.:
Serial no.:	
Purchased from:	
Date purchased:	Date in service:

# Operating Instructions and Parts Manual L-100 Series Hand Chain Hoists



For L100-200 serial no. 15070001 and higher  
For L100-300 serial no. 15070043 and higher  
For L100-1500 serial no. 15070088 and higher

*1-ton model shown*

**Part No. M-106210**  
Revision D1 07/2018



## 1.0 IMPORTANT SAFETY INSTRUCTIONS

### WARNING – To reduce risk of injury:

1. Read and understand the entire owner's manual before attempting assembly or operation.
2. Read and understand the warnings posted on the tool and in this manual. Failure to comply with all of these warnings may cause serious injury and/or damage to property.
3. Replace the warning labels if they become obscured or are missing.
4. Keep visitors a safe distance from the work area. **Keep children away.**
5. Give your work undivided attention. Looking around, carrying on a conversation and "horse-play" are careless acts that can result in serious injury.
6. Provide for adequate space surrounding work area and non-glare, overhead lighting.
7. This chain hoist is designed and intended for use by properly trained and experienced personnel only. If you are not familiar with the proper and safe operation of a chain hoist, do not use until proper training and knowledge have been obtained.
8. Do not use this chain hoist for other than its intended use. If used for other purposes, JET disclaims any real or implied warranty and holds itself harmless from any injury that may result from that use.
9. Do not use to lift people or loads over people.
10. Do not exceed the rated capacity of the chain hoist.
11. Do not use more than hand power to pull the hand chain.
12. Do not use the load chain as a sling; this may cause damage to the chain.
13. Always inspect the chain hoist for damage prior to use. If the chain hoist is damaged, do not use until it has been repaired or replaced.
14. Do not use more than one chain hoist to lift or move a load. If this is unavoidable, each chain hoist must have the same capacity as the load to be moved.
15. Never allow the load chain to "set" over sharp edges. All lifts must be made with straight chain that is free of obstacles.
16. If the hand chain is difficult to operate, then the load exceeds the capacity of the chain hoist. Select a chain hoist of larger capacity.
17. Do not use a chain hoist unless load is centered between top and bottom hooks.
18. Always take time to study the job to be performed and choose the safest method. Do not place yourself or other people in an unsafe position.
19. Stand to one side of the load being lifted and make sure no one else is standing underneath when lifting a load. Should a load slip, it will descend at a high rate of speed and can cause serious injuries to anyone standing directly underneath.
20. Leave all internal maintenance to a qualified JET Service Center.
21. Replace the chain with factory replacement chain only. Do not use any other type of chain.
22. If welding near the hoist, do not allow the chain or hook to be touched by a live electrode. Prevent weld splatter upon the chain.
23. Never use the chain hoist if either hook is stretched, deformed, or has a broken or missing safety latch. Always replace the safety latch and/or the hook before placing the chain hoist back into service.
24. Understand and follow all procedures as set forth in American National Standards titled "Performance Standard for Hand Chain Manually Operated Chain Hoists." ANSI/ASME HST-2; and "Overhead Hoists (Underhung)," ANSI/ASME B30.16.



**WARNING:** This product can expose you to chemicals including lead, which is known to the State of California to cause cancer and birth defects or other reproductive harm.

**Familiarize yourself with the following safety notices used in this manual:**

**CAUTION** This means that if precautions are not heeded, it may result in minor injury and/or possible tool damage.

**WARNING** This means that if precautions are not heeded, it may result in serious injury or possibly even death.

## 2.0 Table of Contents

1.0	IMPORTANT SAFETY INSTRUCTIONS	2
2.0	Table of Contents	3
3.0	Introduction	4
4.0	Specifications	5
5.0	Using the Chain Hoist	6
5.1	Prior to Operation	6
5.2	Hooking the Load	7
5.3	Raising the Load	7
6.0	Hand Chain – Cutting and Installing	8
7.0	Load Chain and Bottom Hook	9
7.1	Load Chain Inspection (all models)	9
7.2	Load Chain Removal (all models)	9
7.3	Attaching Load Chain to Load Chain Sprocket (all models)	9
7.4	Load Chain and Bottom Hook Installation	10
7.5	Chain Installation: 0.5- to 2-Ton Hoists	10
7.6	Chain Installation: 3- to 5-Ton Hoists	10
7.7	Chain Installation: 10- to 20-Ton Hoists	11
8.0	Overload Protection	11
9.0	Inspection and Maintenance	12
10.0	Load Limits	13
10.1	Load Chain	13
10.2	Hooks (Top & Bottom)	13
11.0	Troubleshooting JET® Manual Chain Hoists	14
12.0	Timing Marks for Gear Replacement	15
13.0	Replacement Parts	15
13.1.1	L-100 Chain Hoist Parts Breakdown	16
13.1.2	Parts List: L100-25 Chain Hoist (0.25 Ton)	17
13.1.3	Parts List: L100-50 Chain Hoist (0.5 Ton)	19
13.1.4	Parts List – L100-100 Chain Hoist (1 Ton)	21
13.1.5	Parts List – L100-150 Chain Hoist (1.5 Ton)	23
13.1.6	Parts List – L100-200 Chain Hoist (2 Ton)	25
13.1.7	Parts List – L100-300 Chain Hoist (3.0 Ton)	27
13.1.8	Parts List – L100-500 Chain Hoist (5 Ton)	29
13.1.9	Parts List – L100-1000 Chain Hoist (10 Ton)	31
13.1.10	Parts List – L100-1500 Chain Hoist (15 Ton)	33
13.1.11	Parts List – L100-2000 Chain Hoist (20 Ton)	35
14.0	Warranty and Service	37

## 3.0 Introduction

This manual is provided by JET covering the safe operation and maintenance procedures for a JET Model L-100 Series Chain Hoist. This manual contains instructions on installation, safety precautions, general operating procedures, maintenance instructions and parts breakdown. This hoist has been designed and constructed to provide consistent, long-term operation if used in accordance with instructions set forth in this manual.

**The L-100 Chain Hoist complies with ANSI/ASME B30.16 and HST-2 standards.**

# 4.0 Specifications

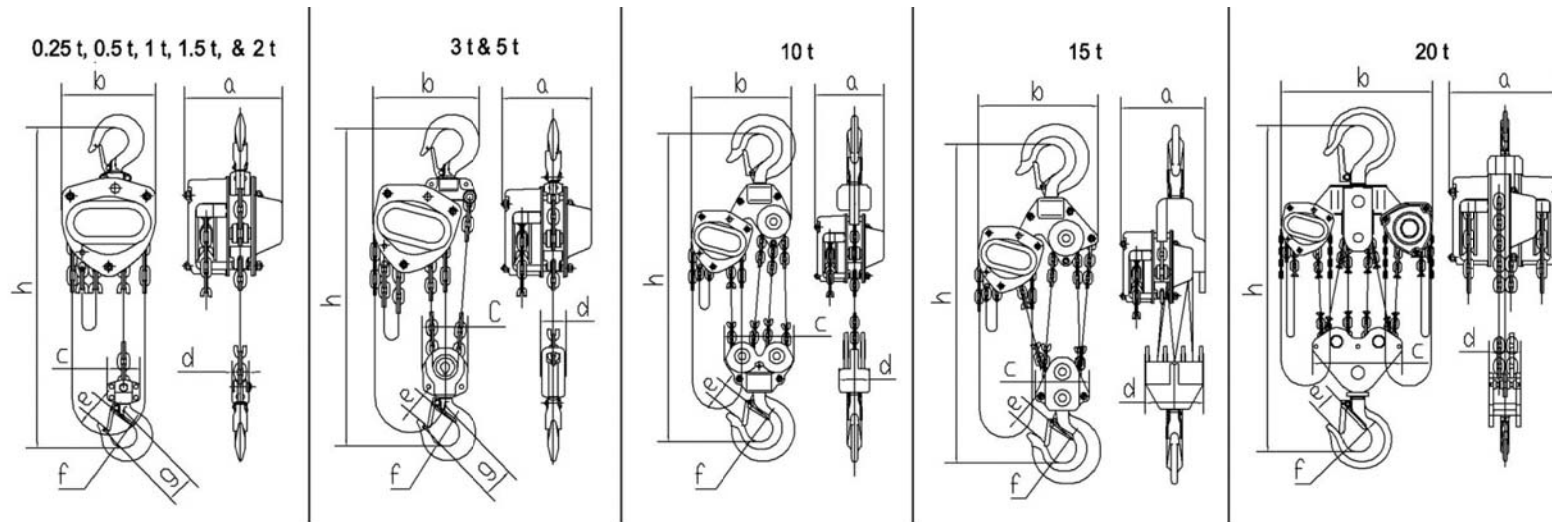

Stock Number	Model	Rated Capacity (ton)	No. of Falls	Load Chain (mm)	Hand Chain (mm)	Pounds of pull to lift capacity	Req'd Hand Chain (ft.) to lift load 1 foot	Net Weight (lbs)	Dimensions							
									a (in)	b (in)	c (in)	d (in)	e (in)	f (in)	g (in)	Headroom h (in)
100210	L100-25-*	1/4	1	4 x 12	3 x 15	41.8	18	9	3-3/4	4-5/16	1-3/16	13/16	1-1/16	1-1/4	1-3/8	9-13/16
106210	L100-50-*	1/2	1	5 x 15	4.8 x 22	51.3	25	10	5-1/8	5-1/2	1-11/16	1	1-1/16	1-1/4	1-3/8	11-1/4
101210	L100-100-*	1	1	6.3 x 19	5 x 25	63.9	43	12	6-3/8	6-5/16	2	1-3/16	1-5/16	1-9/16	1-3/4	11-5/8
101610	L100-150-*	1-1/2	1	7.1 x 21	5 x 25	77	57	15	6-11/16	7-3/16	2-1/2	1-5/16	1-5/16	1-5/8	1-7/8	13-3/4
102210	L100-200-*	2	1	8 x 24	5 x 25	79.4	70	20	7-1/4	8	2-1/2	1-5/16	1-7/16	1-13/16	2-1/16	14-3/4
103210	L100-300-*	3	2	7.1 x 21	5 x 25	79.4	114	24	6-11/16	9-1/4	4-3/16	2-1/16	1-11/16	2-1/16	2-7/16	20-1/16
105510	L100-500-*	5	2	9 x 27	5 x 25	74.9	198	41	7-9/16	11-1/8	5-1/4	2-1/2	2	2-3/8	3-1/8	23-5/8
101010	L100-1000-*	10	4	9 x 27	5 x 25	79.4	396	83	7-9/16	14-3/16	10-3/8	3-3/4	2-1/2	3-3/8	-	29-15/16
101110	L100-1500-*	15	6	9 x 27	5 x 25	81.6	594	287	7-7/8	19-3/8	4-5/16	6-1/8	3-1/8	3-15/16	-	33-7/8
102010	L100-2000-*	20	8	9 x 27	5 x 25	79.4 x 2	396 x 2	381	9-1/16	25-13/16	11-1/4	4-13/16	3-1/4	4-5/16	-	34-1/4

\* The above model and stock numbers are representative; chain is available in other lengths. Specify required chain length when ordering. These models are also available with slip clutch overload protection.

The above specifications were current at the time this manual was published, but because of our policy of continuous improvement, JET reserves the right to change specifications at any time and without prior notice, without incurring obligations.

## 5.0 Using the Chain Hoist

### 5.1 Prior to Operation

1. Support for the hoist may be hook, clevis pin, trolley, or beam clamp. Whatever method of suspension is chosen, the support components **must** be rated equal to, or greater than the capacity of the chain hoist.
2. If the chain hoist has not been used for an extended period of time, check for proper operation before putting into service.
3. The brake mechanism must be kept clean and free from dirt, water, and oil. Never allow oil to penetrate the brake mechanism. Always keep your chain hoist clean and store in a clean, dry location.
4. Although oiling the chain is not mandatory, a light coat of 30-weight oil applied periodically to the chain will create easier operation and prolong the life of the chain.
5. Check the chain for damage and elongation. Replace damaged chain before using the chain hoist.

The load chain supplied with your JET chain hoist is designed, manufactured, and tested for proper fit and durability. Over a period of time, the chain may need to be replaced. For your own safety, use factory replacement chain only.

**WARNING** Use of other than factory replacement chain may cause serious injury and/or damage to the hoist.

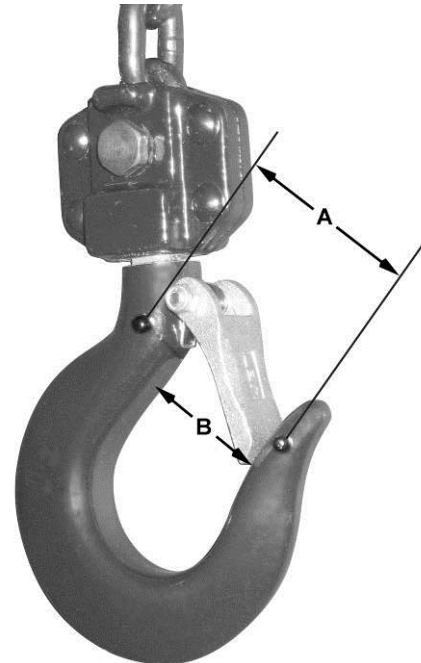

Figure 1

6. The top and bottom hooks on your JET chain hoist are designed to open to warn of an overload. Both top and bottom hooks for 0.5 to 5 ton hoists have two indicator points (A, Figure 1) cast into the hook for measurement. Refer to Table 2 (page 13) to determine if a hook needs to be replaced.

Hooks for 10- and 20-ton hoists do not have indicator points. Measurements are made at the jaw opening (B, Figure 1).

7. It is important to check top and bottom hooks for proper opening. If the safety latch no longer contacts the hook opening, replace the hook. **Never side load the top or bottom hook; this practice is dangerous and could lead to serious injury.**
8. If the vertical angle at the neck of the bottom or top hook reaches 10°, replace the hook (see Figure 2).

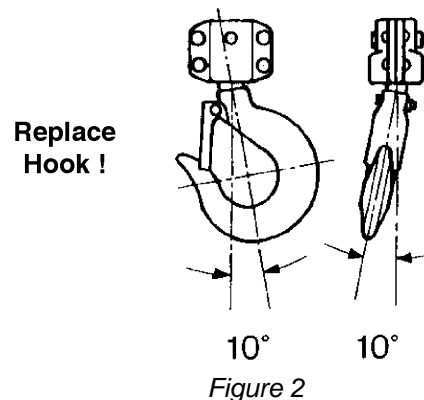

Figure 2

## 5.2 Hooking the Load

1. Secure the upper hook.
2. Place the bottom hook securely into the object to be lifted.
3. Place ropes or chain in the center of the bottom hook, making sure the safety latch is secure. Never load the hook in front of the safety latch. See Figure 3.
4. Avoid lifting one load with two hoists. If this is unavoidable, apply equal weight to both hoists and use hoists with the proper lift capacity. **Capacity of each hoist must be equal to the total load to be lifted.**
5. Check that the chain is not twisted at the bottom hook. All welds should face the same direction (Figure 4).
6. For hoists with two or more falls of chain, make sure the bottom hook is not turned over. This may cause the chain to twist.

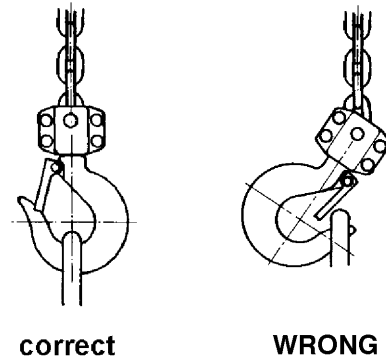

Figure 3

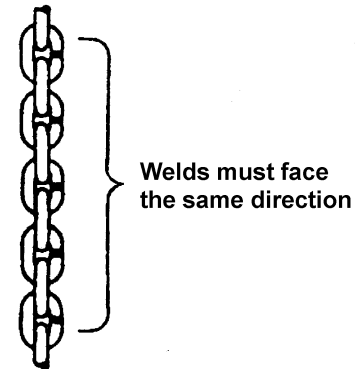

Figure 4

## 5.3 Raising the Load

To raise the load, pull the right side of the hand chain (A, Figure 5) clockwise.

To lower the load, pull the left side of the hand chain (B, Figure 5) counterclockwise.

**Important:** Make sure the hoist has an adequate length of load chain to raise or lower the load in a safe manner. Do not attempt to lower the hoist beyond its limit.

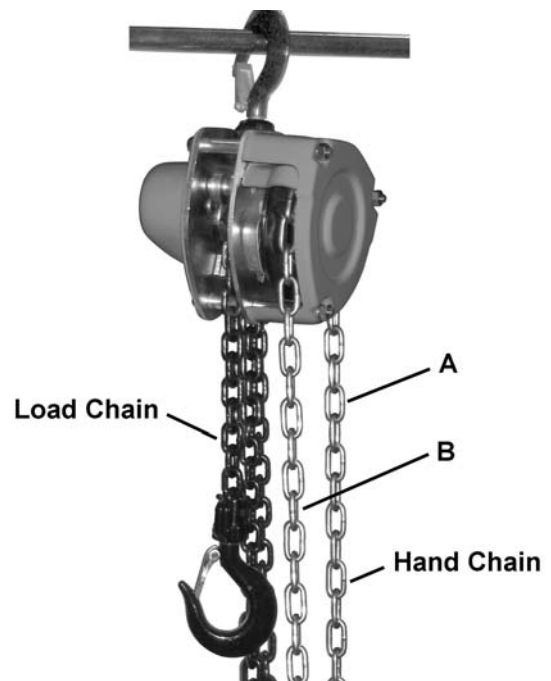

Figure 5

## 6.0 Hand Chain – Cutting and Installing

To cut the hand chain in order to increase or shorten:

To change the length of the *hand chain*, the chain must be cut and links *added* to increase the overall length or links *removed* to decrease the length. This is done as follows:

1. Insert one link lengthwise into the vise (Figure 6). Be sure that the side opposite the weld lies completely below the surface of the vise jaw (about 1/3 of a link). This prevents nicking or cutting the lower part of the link.
2. Using a hack saw, cut through the upper part of the link at the weld.
3. Loosen the link, reposition the link vertically at the edge of the vise with the level of the cut above the vise jaw (Figure 7).
4. Tighten the vise jaw.
5. Using an adjustable wrench, twist the link horizontally from front to back. (Figure 8) Open just far enough to insert (or remove) a second chain link.

**Note:** Chain length is now ready to lengthen or shorten.

6. Insert or remove the second end link at the opening in the first end link.
7. Using an adjustable wrench, twist the link horizontally until the link is in the original closed position. See Figure 9.

**CAUTION** Do not push the link inward from the curved ends. This will distort the link. Check that the link is closed and free of twist.

8. If installing entire new chain, insert the end of the hand chain into the groove at the top of the hand chain wheel (see Figure 10). Rotate the hand chain wheel and pull the chain through.
9. Re-weld the link at the cut.
10. Grind off excess on the weld so that it is smooth.

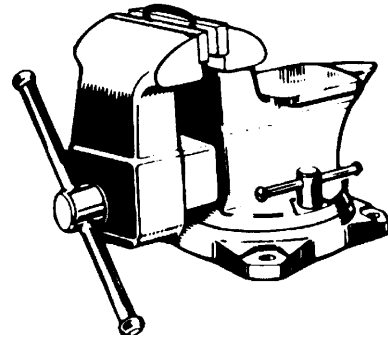

Figure 6

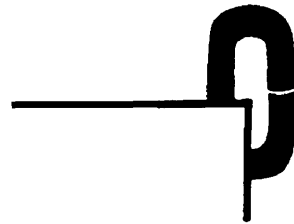

Figure 7

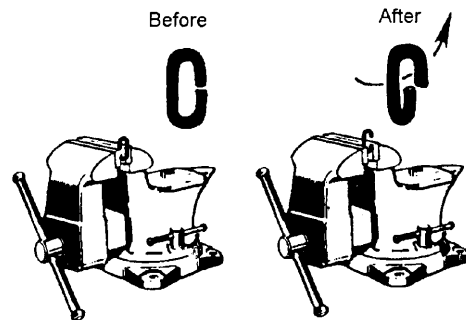

Figure 8



Figure 9



## 7.0 Load Chain and Bottom Hook

### 7.1 Load Chain Inspection (all models)

Over time, the load chain will wear or elongate. This can cause damage to the hoist, breakage, or non-engagement of the load sheave.

**⚠WARNING** Do not operate the hoist with a twisted, kinked or damaged load chain. Do not splice the load chain. Check the chain for excessive wear or stretch. Failure to comply may cause serious injury.

1. Test the hoist under load in both the lifting and lowering directions, observing the operation of chain and sprockets. Chain should feed smoothly into and away from the sprockets.
2. If the chain binds, jumps, or is noisy, make sure it is clean and properly lubricated. If the trouble persists, inspect the chain and mating parts for wear, distortion, or other damage.
3. Clean the chain before inspection. Examine for gouges, nicks, weld splatter, corrosion, and distorted links. Slacken the chain and move adjacent links to one side, looking for wear at the contact points. If you see wear or suspect stretching, measure the chain as follows:
  - Select an unworn, unstretched length of chain (i.e. at the slack end).
  - Suspend the chain vertically under tension and, using a caliper type gauge, measure the outside length of several links about 12 to 24 inches.
  - Measure the same number of links in used sections and calculate the percentage of the increase in length.
4. If the length of used chain exceeds 2-1/2 percent of the unused chain, replace the chain. (See "Load Limits" on page 13 for specific link measurements.)

**⚠WARNING** Do not add to the load chain. Replace the entire chain. Failure to comply may cause serious injury.

### 7.2 Load Chain Removal (all models)

Remove the old load chain as follows while referring to Figure 11:

1. Remove the *cotter pin* (A) and the *chain anchor pin* (C) on the *chain anchor* (D), allowing the end of the chain to fall free.
2. Pull the *hand chain* (Fig. 5) until the load chain is completely removed from the gear assembly.

### 7.3 Attaching Load Chain to Load Chain Sprocket (all models)

Install the new load chain onto the load chain sprocket as follows, referring to Fig. 10:

1. Position the *load chain sprocket* by rotating the *hand chain wheel* so that the wide and narrow grooves show.
2. Insert the load chain into the sprocket grooves so that the chain will wind up and back over the sprocket. *Welds must face away from the sprocket.*
3. Rotate the hand chain wheel so that the load chain falls six to eight inches at the back of the sprocket.

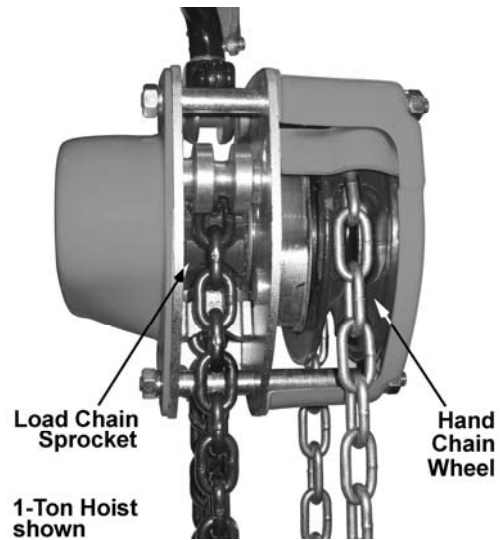

Figure 10

Referring to Figure 11:

4. Insert one end of the *chain link* (B) into the *chain anchor* (D).
5. Insert the *chain anchor pin* (C) through the *chain anchor* (D) and *chain link* (B) and secure with the *cotter pin* (A).

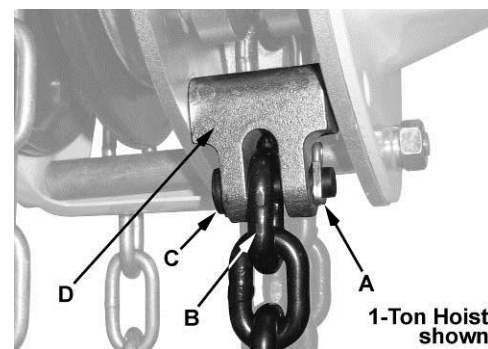

Figure 11

Continue with *Load Chain and Bottom Hook Installation* on the following page, proceeding to the section that applies to your hoist: 1/2- to 2-Ton hoists, 3- to 5-Ton hoists, or 10- to 20-Ton Hoists.

## 7.4 Load Chain and Bottom Hook Installation

The following procedure assumes that the *load chain* has been attached to the *chain anchor* (A, Figure 12) and fed through the *load chain sprocket* as described in the previous section. This section completes the load chain and bottom hook installation.

## 7.5 Chain Installation: 0.5- to 2-Ton Hoists

Referring to Figure 12:

1. Remove the *lock nut* and *bolt* from the *lower hook* (D).
2. Insert the last *chain link* (C) into the lower hook slot.
3. Re-insert the bolt through the lower hook slot and chain link.
4. Re-attach the lock nut to the bolt and tighten.

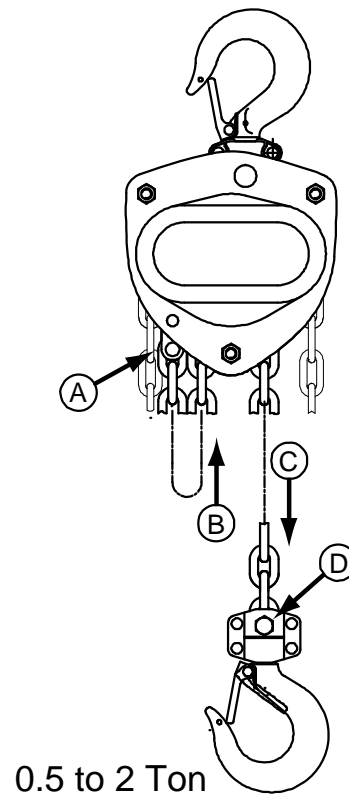

Figure 12

## 7.6 Chain Installation: 3- to 5-Ton Hoists

Referring to Figure 13:

1. After installing the load chain into the *load chain sprocket* (B), run the remaining chain through your hand to remove any twist. The last link of the chain must be in the same direction as the first. If not, cut off the last link.
2. Insert the last link into the pulley of the lower hook (C).
3. Pull the load chain through and up from the underside of the *pulley* (C, D).
4. Remove the cotter pin and chain anchor pin in the *upper hook slot* (E).
5. Insert the last link into the upper hook slot.
6. Check that the load chain is not twisted.
7. Re-position the chain anchor pin back through the upper hook slot and the last chain link and secure with the cotter pin.

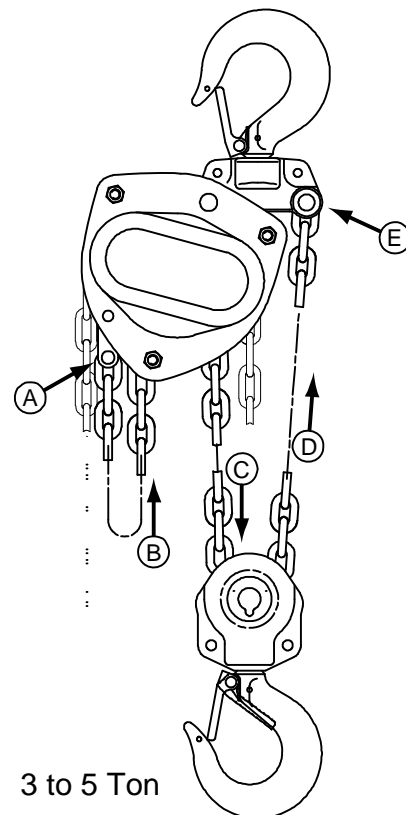

Figure 13

## 7.7 Chain Installation: 10- to 20-Ton Hoists

Referring to Figure 14:

1. After installing the load chain into the load chain sprocket (B), run the remaining chain through your hand to remove any twist. The last link of the chain must be in the same direction as the first. If not, cut off the last link.
2. Insert the last link into the left side pulley of the lower hook (C).
3. Pull the load chain through and up from the underside of the pulley (C, D).
4. Insert the last link into the right hand pulley of the upper hook, moving the chain up, then around and down (D, E). Check that the load chain is not twisted and *welds face away from the pulley*.
5. Insert the last link into the right side pulley of the lower hook, pulling around, then up from the underside of the pulley (E, F). Check that the load chain is not twisted and *welds face away from the pulley*.
6. Remove the *cotter pin* and *chain anchor pin* in the *upper hook slot* (G).
7. Insert the last link into the upper hook slot.
8. Check that the load chain is not twisted.

Re-position the *chain anchor pin* back through the upper hook slot and the last chain link and secure with the *cotter pin*.

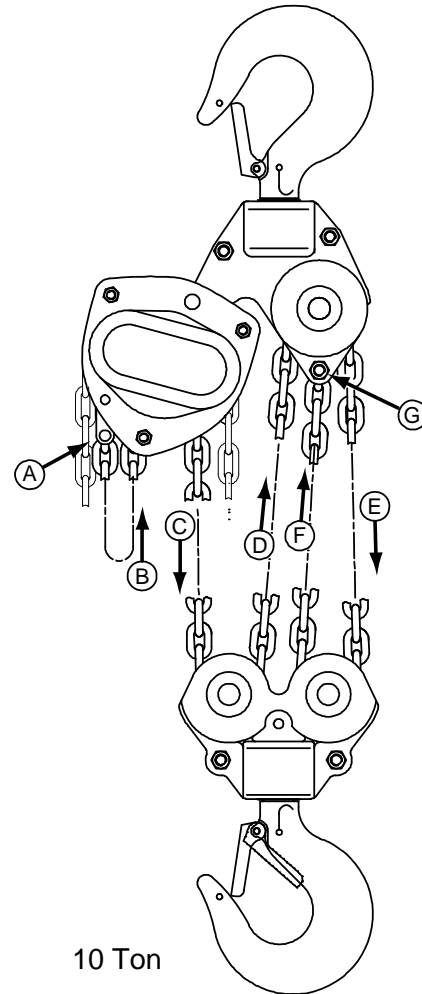

Figure 14

## 8.0 Overload Protection

Some models of the L-100 Hoist have overload protection in the form of a slip clutch (these are identified by "WO" in the model number). The slip clutch is effective at 160% +/-20% of the rated hoist capacity.

The slip clutch will allow the hand chain pulley to move without lifting the load, if the load is too heavy for the hoist. The slip clutch has been pre-adjusted at the factory and should not require any adjustment by the user. If future adjustment or repair to the slip clutch should ever be needed, this must be done by qualified personnel.

## 9.0 Inspection and Maintenance

Read and follow ANSI Inspection and Maintenance Instructions. Know the meaning of Frequent Inspection, Periodic Inspection, Normal Service, Heavy Service, and Severe Service. It is the customer's responsibility to understand and follow all ANSI and JET inspection and maintenance instructions.

**⚠WARNING** All repairs and adjustments are to be performed by trained and experienced personnel using procedures that are approved for the hoist system being serviced. Failure to comply may cause serious injury.

**⚠WARNING** All safety related deficiencies discovered in the inspection are to be corrected before the hoist is to be placed back into service. Failure to comply may cause serious injury.

**⚠WARNING** Check for internal damage whenever external damage has occurred. Failure to comply may cause serious injury.

1. Clean hoist after each use and oil lightly. NOTE: Do not get oil on brake system.
2. Do not drop or drag the hoist.
3. Store the hoist in a clean and dry environment.
4. While not mandatory, periodically oiling the chain with SAE 30 oil will increase its life.
5. Leave all repairs and adjustments of internal parts to qualified repair personnel.
6. Inspect the load chain and the lower hook after lifting a maximum weight load.
7. This hoist uses special alloy hoisting chain and does not interchange with any other manufacturer. Check and inspect the brake system frequently.
9. Annually, the hoist should be disassembled, inspected, and cleaned by trained and experienced personnel only.
10. After servicing, test the hoist with no load, then test the hoist with a load.

# 10.0 Load Limits

## 10.1 Load Chain

Capacity	5 Links Normal	5 Links Limit
0.25 ton	2.36"	2.43"
0.5 ton	2.95"	3.04"
1 ton	3.74"	3.85"
1.5 ton	4.13"	4.25"
2 ton	4.72"	4.86"
3 ton	4.13"	4.25"
5 ton	5.31"	5.47"
10 ton	5.31"	5.47"
15 ton	5.31"	5.47"
20 ton	5.31"	5.47"

Table 1

Carefully inspect the entire load chain. As illustrated in Figure 15, measure five consecutive links with callipers to measure the length. Check every three feet and especially where excessive wear is indicated. Any load chain that shows noticeable deformation or heat influence must be replaced with a new one. Never extend load chain by welding a second piece to the original.

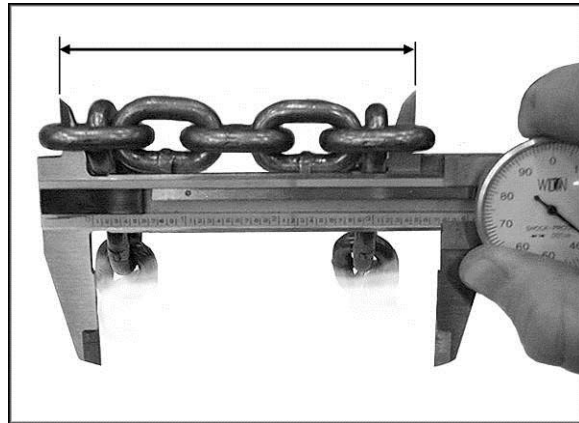

Figure 15

## 10.2 Hooks (Top & Bottom)

Capacity	"A" Norm	"A" Limit	"B" Norm	"B" Limit
0.25 ton	1.39"	1.47"	--	--
0.5 ton	1.36"	1.44"	--	--
1 ton	1.77"	1.88"	--	--
1.5 ton	1.86"	1.97"	--	--
2 ton	2.05"	2.17"	--	--
3 ton	2.45"	2.60"	--	--
5 ton	3.06"	3.24"	--	--
10 ton	--	--	2.52"	2.67"
15 ton	--	--	3.15"	3.34"
20 ton	--	--	3.23"	3.42"

Table 2

See Figure 16. Replace the hook when the "A" measurement is wider than "A" Limit in the table above. Never heat-treat the hook or attach anything to the hook by welding.

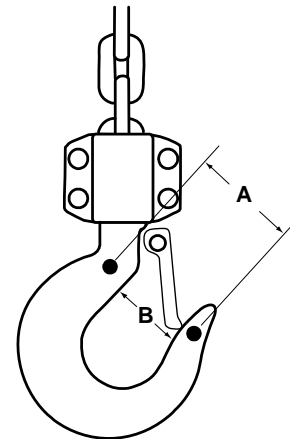

Figure 16

## 11.0 Troubleshooting JET® Manual Chain Hoists

Symptom	Possible Cause	Correction <sup>1</sup>
Hoist will not move in either direction.	Hand chain wheel is jammed, worn, or damaged.	Inspect and clean hand chain and hand chain wheel. Replace if worn or damaged.
	Hand chain slips over wheel.	Check hand chain wheel for damage or worn cogs. Replace if needed.
	Load sheave or load chain is jammed.	Inspect and clean. Check for chain link deformation. Replace elements if needed. Oil load chain for optimal performance.
	Load gear/spur gears jammed due to obstruction or damage.	Inspect, clean, and re-grease gears. Replace if worn or damaged.
	Bearing failure.	Contact JET service center for disassembly and replacement of bearings.
Hoist will not lift load, or lifts with great difficulty.	Load too heavy for hoist.	Use a hoist with proper capacity for load.
	<i>(models with overload protection<sup>2</sup>):</i> Slip clutch overload protection has been triggered due to excess load capacity.	Disengage overload to reset hoist (see instruction manual). Only lift loads within hoist capacity. Inspect hoist elements for damage after overload has occurred.
	Load chain is binding.	Inspect and clean load chain, load sheave, and stripper. Make sure chain is not twisted. Oil chain for optimal performance. Replace elements if deformation or other damage is found.
	Load sheave is jammed.	Inspect and clean. Replace load sheave if damaged or excessively worn.
	Ratchet disc teeth, pawls or pawl springs worn or damaged.	Inspect elements and replace if needed.
	Bearing failure.	Contact JET service center for disassembly and replacement of bearings.
Hoist will not lower load, or lowers with great difficulty.	Load chain is binding due to obstruction, damage or wear.	Inspect and clean load chain and load sheave. Keep load chain lightly oiled. Replace chain if damaged or worn.
	Brake/ratchet disc not releasing due to obstruction or damage.	Inspect and clean ratchet and pawl assemblies.
Load drifts downward while suspended.	Load beyond capacity of hoist.	Use properly rated hoist for load.
	Ratchet disc teeth, pawls or pawl springs worn or damaged.	Inspect elements and replace if needed.
	Brake disc(s) worn or dirty.	Inspect brake disc(s) for wear or damage. Consult thickness tolerances in manual, replace if needed.
Load chain jumps, or makes excessive noise.	Load chain is dirty or dry.	Inspect and clean load chain and load sheave. Oil chain for optimum performance.
	Load chain kinked or twisted.	Remove twists in chain.
	Load chain is worn or deformed, or otherwise damaged.	Replace chain (use JET-authorized chain only).
	Chain catching in load sheave.	Inspect and clean chain and sheave. Check for chain deformations.
Hook latch not closing.	Latch is bent or broken.	Replace latch.
	Hook is deformed preventing proper latch operation.	Replace hook assembly.

<sup>1</sup> Some corrections may need to be performed by a JET authorized service center.

<sup>2</sup> Identified by "WO" in model number.

# 12.0 Timing Marks for Gear Replacement

If the gears on the L-100 hoist need replacement or removal for any reason, make sure they are re-installed correctly. Figure 17 shows the proper orientation of the timing marks when meshing the gears.

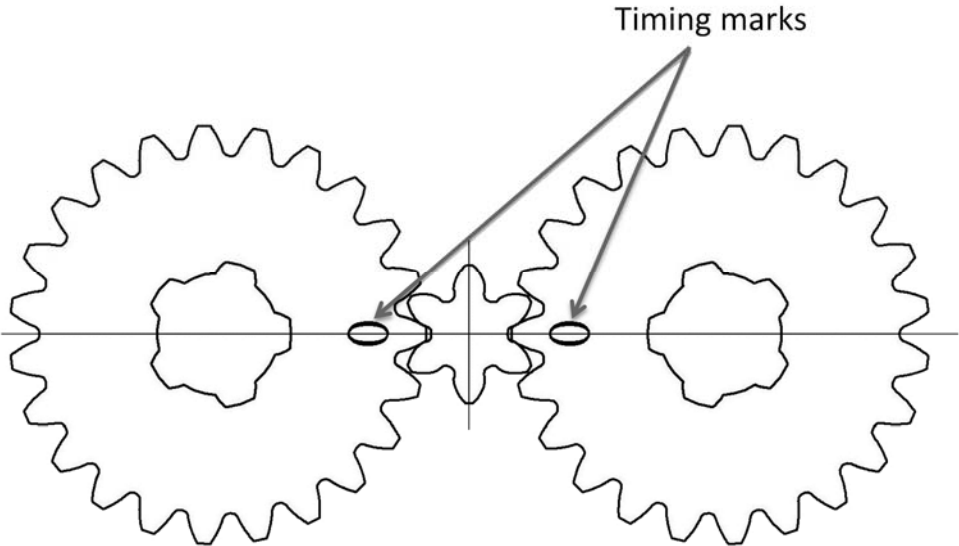

Figure 17

# 13.0 Replacement Parts

Replacement parts are listed on the following pages. Having the Model Number and Serial Number of your machine available when you call will allow us to serve you quickly and accurately.

Non-proprietary parts, such as fasteners, can be found at local hardware stores, or may be ordered from JET.

Some parts are shown for reference only, and may not be available individually.

Parts List: Chain Block L100

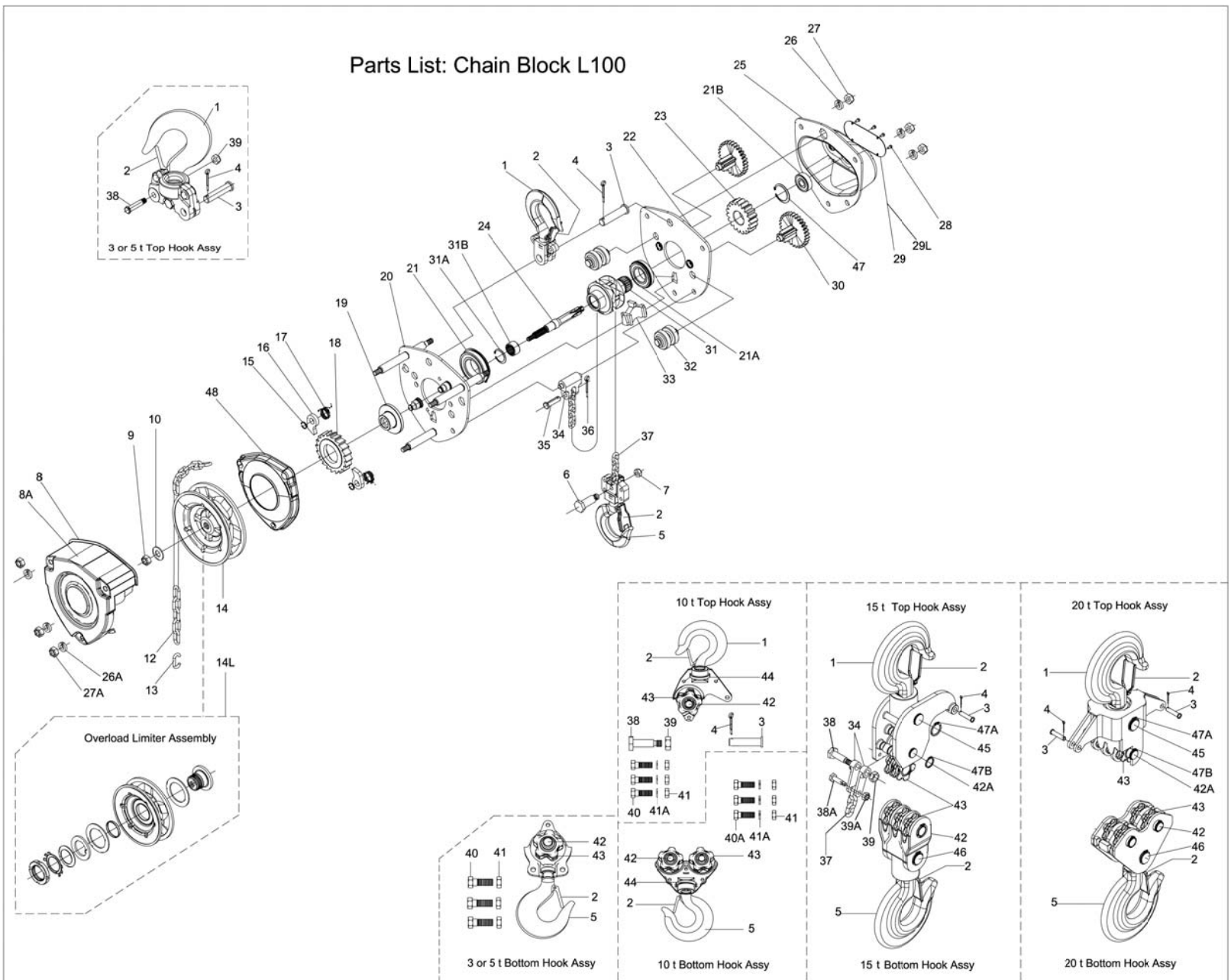



### 13.1.2 Parts List: L100-25 Chain Hoist (0.25 Ton)

Parts listed under each assembly are parts that make up that assembly (sold as an assembly only).

Index No.	Part No.	Description	Size	Qty
1	L100-25-1	Top Hook Assembly		1
		Top Hook		1
		Safety Latch		1
		Double Spring		1
		Socket Head Cap Screw	M4x20	1
		Lock Nut	M4	1
		Top Hook Holder		1
		Rivet	4x14 mm	2
2	L100-25-2	Safety Latch Assembly		2
		Safety Latch		2
		Double Spring		2
		Socket Head Cap Screw	M4x20	2
		Lock Nut	M4	2
3	L100-25-3	Top Hook Shaft		1
4	L100-25-4	Split Pin	2.5x20 mm	1
5	L100-25-5	Bottom Hook Assembly		1
		Bottom Hook		1
		Safety Latch		1
		Double Spring		1
		Socket Head Cap Screw	M4x20	1
		Lock Nut	M4	1
		Rivet	5x20 mm	2
6	L100-25-6	Bottom Hook Shaft		1
7	F001752	Lock Nut (Black Oxide)	M5	1
8	L100-25-8G	Hand Wheel Cover Assembly		1
		Hand Wheel Cover		1
		Hand Chain Guide		2
8A	L100-25-8A	Warning Label		1
9	L100-25-9-1	Wheel Stopper	M6	1
10	L100-25-10-1	Wheel Washer		1
12	L100-25-12	Hand Chain – <i>specify length</i>	3x15 mm	1
13	L100-25-13	Hand Chain Connecting Link		1
14	L100-25-14-1	Hand Chain Wheel		1
14L	L100-25WO-14L	Overload Limiter Assembly ( <i>used on overload protection model</i> )		1
		Overload Limiter Knob		1
		Brake Disc		2
		Hand Chain Wheel		1
		Bushing in Hand Chain Wheel		1
		Disc Spring Plate		1
		Disc Spring		1
		Disc Spring Stopper		1
		Lock Nut		1
15	L100-25-15	Snap Ring	5 mm	2
16	L100-25-16	Pawl		2
17	L100-25-17	Pawl Spring		2
18	L100-25-18-1	Ratchet Disc Assembly		1
		Ratchet Disc		1
		Ratchet Bushing		1
19	L100-25-19-1	Disc Hub		1
20	L100-25-20-1	Wheel Side Plate Assembly		1
		Wheel Side Plate		1
		Pawl Pin		2
		Brake Cover		1
		Double Seal Ball Bearing	d25xD42x9 mm	1
21	L100-25-21	Double Seal Ball Bearing	d20xD37x9 mm	1
21A	L100-25-21A	Double Seal Ball Bearing	d25xD42x9 mm	1
21B	L100-25-21B	Double Seal Ball Bearing	d6xD15x5 mm	1

## Parts List: L100-25 Chain Hoist (0.25 Ton)

Index No.	Part No.	Description	Size	Qty
22	L100-25-22	Gear Side Plate Assembly		1
		Gear Side Plate		1
		Bushing		2
		Double Seal Ball Bearing	d25xD42x9 mm	1
23	L100-25-23	Load Gear		1
24	L100-25-24-1	Drive Shaft		1
25	L100-25-25G	Gear Case Assembly		1
		Gear Case		1
		Bushing		2
		Double Seal Ball Bearing	d10xD22x6 mm	1
26	F002114	Lock Washer (Black Oxide)	M8	3
26A	F002114	Lock Washer (Black Oxide)	M8	3
27	F001753	Lock Nut (Black Oxide)	M6	3
27A	F001753	Lock Nut (Black Oxide)	M6	3
28	L100-25-28	Rivet	2x4 mm	4
29	LM000013	Name Plate, L100-25		1
29	LM000014	Name Plate, L100-25 with overload		1
30	L100-25-30	Spur Gear Assembly		2
		Spur Gear		2
		Pinion Gear		2
31	L100-25-31	Load Sheave		1
31A	L100-25-31A	C-Clip	6.3x2 mm	1
31B	L100-25-31B	Needle Bearing HK1412	d12xD16x8 mm	1
32	L100-25-32	Guide Roller		2
33	L100-25-33	Stripper		1
34	L100-25-34	Chain Anchor Plate		1
35	L100-25-35	Chain Anchor Pin		1
36	L100-25-36	Split Pin	2x12 mm	1
37	L100-25-37	Load Chain – <i>specify length</i>	4x12 mm	1
47	L100-25-47	Snap Ring	18 mm	1
48	L100-25-48G	Dust Cover		1
	L100-WT	Warning Tag (not shown)		1

### Note:

When ordering replacement chain (Index #12, #37), specify length.

### 13.1.3 Parts List: L100-50 Chain Hoist (0.5 Ton)

Parts listed under each assembly are parts that make up that assembly (sold as an assembly only).

Index No.	Part No.	Description	Size	Qty
1	L100-50-1	Top Hook Assembly		1
		Top Hook		1
		Safety Latch		1
		Double Spring		1
		Socket Head Cap Screw	M4x20	1
		Lock Nut	M4	1
		Top Hook Holder		1
		Rivet	5x20 mm	2
2	L100-50-2	Safety Latch Assembly		2
		Safety Latch		2
		Double Spring		2
		Socket Head Cap Screw	M4x20	2
		Lock Nut	M4	2
3	L100-50-3	Top Hook Shaft		1
4	L100-50-4	Split Pin	2x20 mm	1
5	L100-50-5	Bottom Hook Assembly		1
		Bottom Hook		1
		Safety Latch		1
		Double Spring		1
		Socket Head Cap Screw	M4x20	1
		Lock Nut	M4	1
		Rivet	5x20 mm	2
6	L100-50-6	Bottom Hook Shaft		1
7	F001753	Lock Nut	M6	1
8	L100-50-8G	Hand Wheel Cover Assembly		1
		Hand Wheel Cover		1
		Hand Chain Guide		2
8A	L100-50-8A	Warning Label		1
9	L100-25-9-1	Wheel Stopper	M6	1
10	L100-25-10-1	Wheel Washer		1
12	L100-50-12	Hand Chain – <i>specify length</i>	4.8x22 mm	1
13	L100-50-13	Hand Chain Connecting Link		1
14	L100-50-14-1	Hand Chain Wheel		1
14L	L100-50WO-14-1L	Overload Limiter Assembly ( <i>used on overload protection model</i> )		1
		Overload Limiter Knob		1
		Brake Disc		2
		Hand Chain Wheel		1
		Bushing in Hand Chain Wheel		1
		Disc Spring Plate		1
		Disc Spring		1
		Disc Spring Stopper		1
		Lock Nut		1
15	L100-50-15	Snap Ring	7 mm	2
16	L100-50-16	Pawl		2
17	L100-50-17	Pawl Spring		2
18	L100-50-18-1	Ratchet Disc Assembly		1
		Ratchet Disc		1
		Ratchet Bushing		1
19	L100-50-19-1	Disc Hub		1
20	L100-50-20-1	Wheel Side Plate Assembly		1
		Wheel Side Plate		1
		Stay Bolt		3
		Pawl Pin		2
		Brake Cover		1
		Double Seal Ball Bearing	d30xD47x9 mm	1
21	L100-50-21	Double Seal Ball Bearing	d30xD47x9 mm	1
21A	L100-50-21A	Double Seal Ball Bearing	d25xD42x9 mm	1
21B	L100-50-21B	Double Seal Ball Bearing	d10xD22x6 mm	1

## Parts List: L100-50 Chain Hoist (0.5 Ton)

Index No.	Part No.	Description	Size	Qty
22	L100-50-22	Gear Side Plate Assembly		1
		Gear Side Plate		1
		Bushing		2
		Double Seal Ball Bearing	d25x42x9 mm	1
23	L100-50-23	Load Gear		1
24	L100-50-24-1	Drive Shaft		1
25	L100-50-25G	Gear Case Assembly		1
		Gear Case		1
		Bushing		2
		Double Seal Bearing	10dx22Dx6 mm	1
26	F002114	Lock Washer	M8	3
26A	F002114	Lock Washer	M8	3
27	F001754	Lock Nut	M8	3
27A	F001754	Lock Nut	M8	3
28	L100-50-28	Rivet	3x5 mm	4
29	LM000015	Name Plate, L100-50		1
29	LM000016	Name Plate, L100-50 with overload		1
30	L100-50-30	Spur Gear Assembly		2
		Spur Gear		2
		Pinion Gear		2
31	L100-50-31	Load Sheave		1
31A	L100-50-31A	C-Clip	21 mm	1
31B	L100-50-31B	Needle Bearing	d14xD21x12 mm	1
32	L100-50-32	Guide Roller		2
33	L100-50-33	Stripper		1
34	L100-50-34	Chain Anchor Plate		1
35	L100-50-35	Chain Anchor Pin		1
36	L100-50-36	Split Pin	2x12 mm	1
37	L100-50-37	Load Chain – <i>specify length</i>	5x15 mm	1
47	L100-50-47	Snap Ring	22 mm	1
48	L100-50-48G	Dust Cover		1
	L100-WT	Warning Tag (not shown)		1

### Note:

When ordering replacement chain (Index #12, #37), specify length.

### 13.1.4 Parts List – L100-100 Chain Hoist (1 Ton)

Parts listed under each assembly are parts that make up that assembly (sold as an assembly only).

Index No.	Part No.	Description	Size	Qty
1	L100-100-1	Top Hook Assembly		1
		Top Hook		1
		Safety Latch		1
		Double Spring		1
		Socket Head Cap Screw	M4x20	1
		Lock Nut	M4	1
		Top Hook Holder		1
		Rivet	5x20 mm	2
2	L100-100-2	Safety Latch Assembly		2
		Safety Latch		2
		Double Spring		2
		Socket Head Cap Screw	M4x20	2
		Lock Nut	M4	2
3	L100-100-3	Top Hook Shaft		1
4	L100-100-4	Split Pin	2.5x20 mm	1
5	L100-100-5	Bottom Hook Assembly		1
		Bottom Hook		1
		Safety Latch		1
		Double Spring		1
		Socket Head Cap Screw	M4x20	1
		Lock Nut	M4	1
		Rivet	5x20 mm	2
6	L100-100-6	Bottom Hook Shaft		1
7	F001753	Lock Nut	M6	1
8	L100-100-8G	Hand Wheel Cover Assembly		1
		Hand Wheel Cover		1
		Hand Chain Guide		2
8A	L100-50-8A	Warning Label		1
9	L100-100-9-1	Wheel Stopper	M8	1
10	L100-100-10-1	Wheel Washer		1
12	L100-100-12	Hand Chain – <i>specify length</i>	5x25 mm	1
13	L100-100-13	Hand Chain Connecting Link		1
14	L100-100-14-1	Hand Chain Wheel		1
14L	L100-100WO-14-1L	Overload Limiter Assembly ( <i>used on overload protection model</i> )		1
		Overload Limiter Knob		1
		Brake Disc		2
		Hand Chain Wheel		1
		Bushing in Hand Chain Wheel		1
		Disc Spring Plate		1
		Disc Spring		1
		Disc Spring Stopper		1
		Lock Nut		1
15	L100-100-15	Snap Ring	10 mm	2
16	L100-100-16	Pawl		2
17	L100-100-17	Pawl Spring		2
18	L100-100-18-1	Ratchet Disc Assembly		1
		Ratchet Disc		1
		Ratchet Bushing		1
19	L100-100-19-1	Disc Hub		1
20	L100-100-20-1	Wheel Side Plate Assembly		1
		Wheel Side Plate		1
		Stay Bolt		3
		Pawl Pin		2
		Brake Cover		1
		Double Seal Ball Bearing	d30xD55x13 mm	1
21	L100-100-21	Double Seal Ball Bearing	d30xD55x13 mm	1
21A	L100-100-21A	Double Seal Ball Bearing	d25xD47x12 mm	1
21B	L100-100-21B	Double Seal Ball Bearing	d10xD30x9 mm	1

## Parts List: L100-100 Chain Hoist (1 Ton)

Index No.	Part No.	Description	Size	Qty
22	L100-100-22	Gear Side Plate Assembly		1
		Gear Side Plate		1
		Bushing		2
		Double Seal Ball Bearing	d25xD47x12 mm	1
23	L100-100-23	Load Gear		1
24	L100-100-24-1	Drive Shaft		1
25	L100-100-25G	Gear Case Assembly		1
		Gear Case		1
		Bushing		2
		Double Seal Bearing	d10xD30x9 mm	1
26	F002114	Lock Washer	M8	3
26A	F002114	Lock Washer	M8	3
27	F001754	Lock Nut	M8	3
27A	F001754	Lock Nut	M8	3
28	L100-100-28	Rivet	3x6 mm	4
29	LM000017	Name Plate, L100-100		1
29	LM000018	Name Plate, L100-100 with overload		1
30	L100-100-30	Spur Gear Assembly		2
		Spur Gear		2
		Pinion Gear		2
31	L100-100-31	Load Sheave		1
31A	L100-50-31A	C-Clip	21 mm	1
31B	L100-50-31B	Needle Bearing	1d4xD21x12 mm	1
32	L100-100-32	Guide Roller		2
33	L100-100-33	Stripper		1
34	L100-100-34	Chain Anchor Plate		1
35	L100-100-35	Chain Anchor Pin		1
36	L100-100-36	Split Pin	2x15 mm	1
37	L100-100-37	Load Chain – <i>specify length</i>	6.3x19 mm	1
47	L100-50-47	Snap Ring	22 mm	1
48	L100-100-48G	Dust Cover		1
	L100-WT	Warning Tag (not shown)		1

### Note:

When ordering replacement chain (Index #12, #37), specify length.

### 13.1.5 Parts List – L100-150 Chain Hoist (1.5 Ton)

Parts listed under each assembly are parts that make up that assembly (sold as an assembly only).

Index No.	Part No.	Description	Size	Qty
1	L100-150-1	Top Hook Assembly		1
		Top Hook		1
		Safety Latch		1
		Double Spring		1
		Socket Head Cap Screw	M5x25	1
		Lock Nut	M5	1
		Top Hook Holder		1
		Rivet	6x24 mm	2
2	L100-150-2	Safety Latch Assembly		2
		Safety Latch		2
		Double Spring		2
		Socket Head Cap Screw	M5x25	2
		Lock Nut	M5	2
3	L100-300-3	Top Hook Shaft		1
4	L100-100-4	Split Pin	2.5x20 mm	1
5	L100-150-5	Bottom Hook Assembly		1
		Bottom Hook		1
		Safety Latch		1
		Double Spring		1
		Socket Head Cap Screw	M5x25	1
		Lock Nut	M5	1
		Rivet	6x24 mm	2
6	L100-150-6	Bottom Hook Shaft		1
7	F001754	Lock Nut	M8	1
8	L100-300-8G	Hand Wheel Cover Assembly		1
		Hand Wheel Cover		1
		Hand Chain Guide		2
8A	L100-50-8A	Warning Label		1
9	L100-100-9-1	Wheel Stopper	M8	1
10	L100-100-10-1	Wheel Washer		1
12	L100-100-12	Hand Chain – <i>specify length</i>	5x25 mm	1
13	L100-100-13	Hand Chain Connecting Link		1
14	L100-300-14-1	Hand Chain Wheel		1
14L	L100-300WO-14-1L	Overload Limiter Assembly ( <i>used on overload protection model</i> )		1
		Overload Limiter Knob		1
		Brake Disc		2
		Hand Chain Wheel		1
		Bushing in Hand Chain Wheel		1
		Disc Spring Plate		1
		Disc Spring		1
		Disc Spring Stopper		1
		Lock Nut		1
15	L100-100-15	Snap Ring	10 mm	2
16	L100-100-16	Pawl		2
17	L100-100-17	Pawl Spring		2
18	L100-100-18	Ratchet Disc Assembly		1
		Ratchet Disc		1
		Ratchet Bushing		1
19	L100-100-19-1	Disc Hub		1
20	L100-300-20-1	Wheel Side Plate Assembly		1
		Wheel Side Plate		1
		Stay Bolt		3
		Pawl Pin		2
		Brake Cover		1
		Double Seal Ball Bearing	d30xD55x13 mm	1
21	L100-100-21	Double Seal Ball Bearing	d30xD55x13 mm	1
21A	L100-100-21	Double Seal Ball Bearing	d30xD55x13 mm	1
21B	L100-100-21B	Double Seal Ball Bearing	d10xD30x9 mm	1

## Parts List: L100-150 Chain Hoist (1.5 Ton)

Index No.	Part No.	Description	Size	Qty
22	L100-300-22	Gear Side Plate Assembly		1
		Gear Side Plate		1
		Bushing		2
		Double Seal Ball Bearing	d30xD55x13 mm	1
23	L100-300-23	Load Gear		1
24	L100-300-24-1	Drive Shaft		1
25	L100-300-25G	Gear Case Assembly		1
		Gear Case		1
		Bushing		2
		Double Seal Bearing	d10xD30x9 mm	1
26	F002114	Lock Washer	M8	3
26A	F002114	Lock Washer	M8	3
27	F001754	Lock Nut	M8	3
27A	F001754	Lock Nut	M8	3
28	L100-100-28	Rivet	3x6 mm	4
29	LM000019	Name Plate, L100-150		1
29	LM000020	Name Plate, L100-150 with overload		1
30	L100-300-30	Spur Gear Assembly		2
		Spur Gear		2
		Pinion Gear		2
31	L100-300-31	Load Sheave		1
31A	L100-50-31A	C-Clip	21 mm	1
31B	L100-50-31B	Needle Bearing	d14xD21x12 mm	1
32	L100-300-32	Guide Roller		2
33	L100-300-33	Stripper		1
34	L100-300-34	Chain Anchor Plate		1
35	L100-300-35	Chain Anchor Pin		1
36	L100-100-36	Split Pin	2x15 mm	1
37	L100-300-37	Load Chain – <i>specify length</i>	7.1x21 mm	1
47	L100-300-47	Snap Ring	28 mm	1
48	L100-300-48G	Dust Cover		1
	L100-WT	Warning Tag (not shown)		1

**Note:** When ordering replacement chain (Index #12, #37), specify length.



### 13.1.6 Parts List – L100-200 Chain Hoist (2 Ton)

Parts listed under each assembly are parts that make up that assembly (sold as an assembly only).

Index No.	Part No.	Description	Size	Qty
1	L100-200-1	Top Hook Assembly		1
		Top Hook		1
		Safety Latch		1
		Double Spring		1
		Socket Head Cap Screw	M5x25	1
		Lock Nut	M5	1
		Top Hook Holder		1
		Rivet	6x24 mm	2
2	L100-200-2	Safety Latch Assembly		2
		Safety Latch		2
		Double Spring		2
		Socket Head Cap Screw	M5x25	2
		Lock Nut	M5	2
3	L100-200-3	Top Hook Shaft		1
4	L100-100-4	Split Pin	2.5x20 mm	1
5	L100-200-5	Bottom Hook Assembly		1
		Bottom Hook		1
		Safety Latch		1
		Double Spring		1
		Socket Head Cap Screw	M5x25	1
		Lock Nut	M5	1
		Rivet	6x24 mm	2
6	L100-200-6	Bottom Hook Shaft		1
7	F001754	Lock Nut	M8	1
8	L100-200-8G	Hand Wheel Cover Assembly		1
		Hand Wheel Cover		1
		Hand Chain Guide		2
8A	L100-50-8A	Warning Label		1
9	L100-100-9-1	Wheel Stopper	M8	1
10	L100-100-10-1	Wheel Washer		1
12	L100-100-12	Hand Chain – <i>specify length</i>	5x25 mm	1
13	L100-100-13	Hand Chain Connecting Link		1
14	L100-200-14-1	Hand Chain Wheel		1
14L	L100-200WO-14-1L	Overload Limiter Assembly ( <i>used on overload protection model</i> )		1
		Overload Limiter Knob		1
		Brake Disc		2
		Hand Chain Wheel		1
		Bushing in Hand Chain Wheel		1
		Disc Spring Plate		1
		Disc Spring		1
		Disc Spring Stopper		1
		Lock Nut		1
15	L100-100-15	Snap Ring	10 mm	2
16	L100-100-16	Pawl		2
17	L100-100-17	Pawl Spring		2
18	L100-200-18-1	Ratchet Disc Assembly		1
		Ratchet Disc		1
		Ratchet Bushing		1
19	L100-200-19-1	Disc Hub		1
20	L100-200-20-1	Wheel Side Plate Assembly		1
		Wheel Side Plate		1
		Stay Bolt		3
		Pawl Pin		2
		Brake Cover		1
		Double Seal Ball Bearing	d35xD62x14 mm	1
21	L100-500-21	Double Seal Ball Bearing	d35xD62x14 mm	1
21A	L100-100-21	Double Seal Ball Bearing	d30xD55x13 mm	1
21B	L100-500-21B	Double Seal Ball Bearing	d12xD32x10 mm	1

## Parts List – L100-200 Chain Hoist (2 Ton)

Index No.	Part No.	Description	Size	Qty
22	L100-200-22	Gear Side Plate Assembly		1
		Gear Side Plate		1
		Bushing		2
		Double Seal Ball Bearing	d30xD55x13 mm	1
23	L100-200-23	Load Gear		1
24	L100-200-24-1	Drive Shaft		1
25	L100-200-25G	Gear Case Assembly		1
		Gear Case		1
		Bushing		2
		Double Seal Bearing	12x32x10 mm	1
26	F002116	Lock Washer	M10	3
26A	F002114	Lock Washer	M8	3
27	F001755	Lock Nut	M10	3
27A	F001754	Lock Nut	M8	3
28	L100-100-28	Rivet	3x6 mm	4
29	LM000021	Name Plate, L100-200		1
29	LM000022	Name Plate, L100-200 with overload		1
30	L100-200-30	Spur Gear Assembly		2
		Spur Gear		2
		Pinion Gear		2
31	L100-200-31	Load Sheave		1
31A	L100-500-31A	C-Clip	24 mm	1
31B	L100-500-31B	Needle Bearing	17x42x15 mm	1
32	L100-200-32	Guide Roller		2
33	L100-200-33	Stripper		1
34	L100-200-34	Chain Anchor Plate		1
35	L100-200-35	Chain Anchor Pin		1
36	L100-100-36	Split Pin	2x15 mm	1
37	L100-200-37	Load Chain – <i>specify length</i>	8x24 mm	1
47	L100-300-47	Snap Ring	28 mm	1
48	L100-200-48G	Dust Cover		1
	L100-WT	Warning Tag (not shown)		1

**Note:** When ordering replacement chain (Index #12, #37), specify length.

### 13.1.7 Parts List – L100-300 Chain Hoist (3.0 Ton)

Parts listed under each assembly are parts that make up that assembly (sold as an assembly only).

Index No.	Part No.	Description	Size	Qty
1	L100-300-1	Top Hook Assembly		1
		Top Hook		1
		Safety Latch		1
		Double Spring		1
		Socket Head Cap Screw	M5x30	1
		Lock Nut	M5	1
		Top Hook Holder		1
		Rivet	10x32	2
2	L100-300-2	Safety Latch Assembly		2
		Safety Latch		2
		Double Spring		2
		Socket Head Cap Screw	M5x30	2
		Lock Nut	M5	2
3	L100-300-3	Top Hook Shaft		1
4	L100-100-4	Split Pin	2.5x20 mm	1
5	L100-300-5	Bottom Hook Assembly		1
		Bottom Hook		1
		Safety Latch		1
		Double Spring		1
		Socket Head Cap Screw	M5x30	1
		Lock Nut	M5	1
		Idle Shaft		1
		Idle Sheave		1
		Socket Head Cap Screw	M8x25	2
		Lock Nut	M8	2
		Lock Nut	M12	2
		Lock Washer	M12	2
		Bottom Hook Holder		1
8	L100-300-8G	Hand Wheel Cover Assembly		1
		Hand Wheel Cover		1
		Hand Chain Guide		2
8A	L100-50-8A	Warning Label		1
9	L100-100-9-1	Wheel Stopper	M8	1
10	L100-100-10-1	Wheel Washer		1
12	L100-100-12	Hand Chain – <i>specify length</i>	5x25 mm	1
13	L100-100-13	Hand Chain Connecting Link		1
14	L100-300-14-1	Hand Chain Wheel		1
14L	L100-300WO-14-1L	Overload Limiter Assembly ( <i>used on overload protection model</i> )		1
		Overload Limiter Knob		1
		Brake Disc		2
		Hand Chain Wheel		1
		Bushing in Hand Chain Wheel		1
		Disc Spring Plate		1
		Disc Spring		1
		Disc Spring Stopper		1
		Lock Nut		1
15	L100-100-15	Snap Ring	10 mm	2
16	L100-100-16	Pawl		2
17	L100-100-17	Pawl Spring		2
18	L100-300-18-1	Ratchet Disc Assembly	1	1
		Ratchet Disc		1
		Ratchet Bushing		1
19	L100-100-19-1	Disc Hub		1
20	L100-300-20-1	Wheel Side Plate Assembly		1
		Wheel Side Plate		1
		Stay Bolt		3
		Pawl Pin		2
		Brake Cover		1
		Double Seal Ball Bearing	d30xD55x13 mm	1

## Parts List: L100-300 Chain Hoist (3.0 Ton)

Index No.	Part No.	Description	Size	Qty
21	L100-100-21	Double Seal Ball Bearing	d30xD55x13 mm	1
21A	L100-100-21	Double Seal Ball Bearing	d30xD55x13 mm	1
21B	L100-100-21B	Double Seal Ball Bearing	d10xD30x9 mm	1
22	L100-300-22	Gear Side Plate Assembly		1
		Gear Side Plate		1
		Bushing		2
		Double Seal Ball Bearing	d30xD55x13 mm	1
23	L100-300-23	Load Gear		1
24	L100-300-24-1	Drive Shaft		1
25	L100-300-25G	Gear Case Assembly		1
		Gear Case		1
		Bushing		2
		Double Seal Bearing	d10xD30x9 mm	1
26	F002114	Lock Washer	M8	3
26A	F002114	Lock Washer	M8	3
27	F001754	Lock Nut	M8	3
27A	F001754	Lock Nut	M8	3
28	L100-100-28	Rivet	3x6 mm	4
29	LM000023	Name Plate, L100-300		1
29	LM000024	Name Plate, L100-300 with overload		1
30	L100-300-30	Spur Gear Assembly		2
		Spur Gear		2
		Pinion Gear		2
31	L100-300-31	Load Sheave		1
31A	L100-50-31A	C-Clip	21 mm	1
31B	L100-50-31B	Needle Bearing	14x21x12 mm	1
32	L100-300-32	Guide Roller		2
33	L100-300-33	Stripper		1
34	L100-300-34	Chain Anchor Plate		1
35	L100-300-35	Chain Anchor Pin		1
36	L100-100-36	Split Pin	2x15 mm	1
37	L100-300-37	Load Chain – <i>specify length</i>	7.1x21 mm	1
38	L100-300-38	Top Hook Pin		1
39	F001754	Lock Nut	M8	1
40	F005404	Socket Head Cap Screw	M8x25	2
41	F001754	Lock Nut	M8	2
42	L100-300-42	Idle Shaft		1
43	L100-300-43	Idle Sheave		1
47	L100-300-47	Snap Ring	28 mm	1
48	L100-300-48G	Dust Cover		1
	L100-WT	Warning Tag (not shown)		1

**Note:** When ordering replacement chain (Index #12, #37), specify length.

### 13.1.8 Parts List – L100-500 Chain Hoist (5 Ton)

Parts listed under each assembly are parts that make up that assembly (sold as an assembly only).

Index No.	Part No.	Description	Size	Qty
1	L100-500-1	Top Hook Assembly		1
		Top Hook		1
		Safety Latch		1
		Double Spring		1
		Socket Head Cap Screw	M5x30	1
		Lock Nut	M5	1
		Top Hook Holder		1
		Rivet	10x32 mm	2
2	L100-500-2	Safety Latch Assembly		2
		Safety Latch		2
		Double Spring		2
		Socket Head Cap Screw	M5x30	2
		Lock Nut	M5	2
3	L100-500-3	Top Hook Shaft		1
4	L100-500-4	Split Pin	2.5x22 mm	1
5	L100-500-5	Bottom Hook Assembly		1
		Bottom Hook		1
		Safety Latch		1
		Double Spring		1
		Socket Head Cap Screw	M5x30	1
		Lock Nut	M5	1
		Idle Shaft		1
		Idle Sheave		1
		Socket Head Cap Screw	M10x30	3
		Lock Nut	M10	3
		Bottom Hook Holder		1
8	L100-500-8G	Hand Wheel Cover Assembly		1
		Hand Wheel Cover		1
		Hand Chain Guide		2
8A	L100-50-8A	Warning Label		1
9	L100-100-9-1	Wheel Stopper	M8	1
10	L100-100-10-1	Wheel Washer		1
12	L100-100-12	Hand Chain – <i>specify length</i>	5x25 mm	1
13	L100-100-13	Hand Chain Connecting Link		1
14	L100-500-14-1	Hand Chain Wheel		1
14L	L100-500WO-14-1L	Overload Limiter Assembly		1
		Overload Limiter Knob		1
		Brake Disc		2
		Hand Chain Wheel		1
		Bushing in Hand Chain Wheel		1
		Disc Spring Plate		1
		Disc Spring		1
		Disc Spring Stopper		1
		Lock Nut		1
15	L100-100-15	Snap Ring	10 mm	2
16	L100-100-16	Pawl		2
17	L100-100-17	Pawl Spring		2
18	L100-500-18-1	Ratchet Disc Assembly		1
		Ratchet Disc		1
		Ratchet Bushing		1
19	L100-500-19-1	Disc Hub		1
20	L100-500-20-1	Wheel Side Plate Assembly		1
		Wheel Side Plate		1
		Stay Bolt		3
		Pawl Pin		2
		Brake Cover		1
		Double Seal Ball Bearing	d35xD62x14 mm	1
21	L100-500-21	Double Seal Ball Bearing	d35xD62x14 mm	1

## Parts List: L100-500 Chain Hoist (5 Ton)

Index No.	Part No.	Description	Size	Qty
21A	L100-500-21	Double Seal Ball Bearing	d35xD62x14 mm	1
21B	L100-500-21B	Double Seal Ball Bearing	d12xD32x10 mm	1
22	L100-500-22	Gear Side Plate Assembly		1
		Gear Side Plate		1
		Bushing		2
		Double Seal Ball Bearing	d35xD62x14 mm	1
23	L100-500-23	Load Gear		1
24	L100-500-24-1	Drive Shaft		1
25	L100-500-25G	Gear Case Assembly		1
		Gear Case		1
		Bushing		2
		Double Seal Bearing	d12xD32x10 mm	1
26	F002118	Lock Washer	M12	3
26A	F002114	Lock Washer	M8	3
27	F001756	Lock Nut	M12	3
27A	F001754	Lock Nut	M8	3
28	L100-100-28	Rivet	3x6 mm	4
29	LM000025	Name Plate, L100-500		1
29	LM000026	Name Plate, L100-500 with overload		1
30	L100-500-30	Spur Gear Assembly		2
		Spur Gear		2
		Pinion Gear		2
31	L100-500-31	Load Sheave		1
31A	L100-500-31A	C-Clip	24 mm	1
31B	L100-500-31B	Needle Bearing	17x24x15 mm	1
32	L100-500-32	Guide Roller		2
33	L100-500-33	Stripper		1
34	L100-500-34	Chain Anchor Plate		1
35	L100-500-35	Chain Anchor Pin		1
36	L100-500-36	Split Pin	2x18 mm	1
37	L100-500-37	Load Chain – <i>specify length</i>	9x27 mm	1
38	L100-500-38	Top Hook Pin		1
39	F001755	Lock Nut	M10	1
40	F005404	Socket Head Cap Screw	M10x30	3
41	F001755	Lock Nut	M10	3
42	L100-500-42	Idle Shaft		1
43	L100-500-43	Idle Sheave		1
47	L100-500-47	Snap Ring	32 mm	1
48	L100-500-48G	Dust Cover		1
	L100-WT	Warning Tag (not shown)		1

**Note:** When ordering replacement chain (Index #12, #37), specify length.

### 13.1.9 Parts List – L100-1000 Chain Hoist (10 Ton)

Parts listed under each assembly are parts that make up that assembly (sold as an assembly only).

Index No.	Part No.	Description	Size	Qty
1	L100-1000-1	Top Hook Assembly		1
		Top Hook		1
		Safety Latch		1
		Double Spring		1
		Socket Head Cap Screw	M5x30	1
		Lock Nut	M5	1
		Top Hook Holder		1
		Hook Collar Bushing		1
		Idle Shaft		1
		Idle Sheave		1
		Needle Bearing		1
		Socket Head Cap Screw	M12x40	2
		Lock Nut	M12	2
		Lock washer	M12	2
2	L100-1000-2	Safety Latch Assembly		2
		Safety Latch		2
		Double Spring		2
		Socket Head Cap Screw	M5x30	2
		Lock Nut	M5	2
3	L100-500-3	Top Hook Shaft		1
4	L100-500-4	Split Pin	2.5x22 mm	1
5	L100-1000-5	Bottom Hook Assembly		1
		Bottom Hook		1
		Safety Latch		1
		Double Spring		1
		Socket Head Cap Screw	M5x30	1
		Lock Nut	M5	1
		Idle Shaft		2
		Idle Sheave		2
		Needle Bearing		1
		Socket Head Cap Screw	M12x45	3
		Lock Nut	M12	3
		Lock Washer	M12	3
		Hook Collar Bushing		1
		Bottom Hook Holder		1
8	L100-500-8G	Hand Wheel Cover Assembly		1
		Hand Wheel Cover		1
		Hand Chain Guide		2
8A	L100-50-8A	Warning Label		1
9	L100-100-9-1	Wheel Stopper	M8	1
10	L100-100-10-1	Wheel Washer		1
12	L100-100-12	Hand Chain – <i>specify length</i>	5x25 mm	1
13	L100-100-13	Hand Chain Connecting Link		1
14	L100-500-14-1	Hand Chain Wheel		1
14L	L100-1000WO-14-1L	Overload Limiter Assembly ( <i>used on overload protection model</i> )		1
		Overload Limiter Knob		1
		Brake Disc		2
		Hand Chain Wheel		1
		Bushing in Hand Chain Wheel		1
		Disc Spring Plate		1
		Disc Spring		1
		Disc Spring Stopper		1
		Lock Nut		1
15	L100-100-15	Snap Ring	10 mm	2
16	L100-100-16	Pawl		2
17	L100-100-17	Pawl Spring		2
18	L100-500-18-1	Ratchet Disc Assembly		1
		Ratchet Disc		1
		Ratchet Bushing		1

## Parts List: L100-1000 Chain Hoist (10 Ton)

Index No.	Part No.	Description	Size	Qty
19	L100-500-19-1	Disc Hub		1
20	L100-500-20-1	Wheel Side Plate Assembly		1
		Wheel Side Plate		1
		Stay Bolt		3
		Pawl Pin		2
		Brake Cover		1
		Double Seal Ball Bearing	d35xD62x14 mm	1
21	L100-500-21	Double Seal Ball Bearing	d35xD62x14 mm	1
21A	L100-500-21	Double Seal Ball Bearing	d35xD62x14 mm	1
21B	L100-500-21B	Double Seal Ball Bearing	d12xD32x10 mm	1
22	L100-500-22	Gear Side Plate Assembly		1
		Gear Side Plate		1
		Bushing		2
		Double Seal Ball Bearing	d35xD62x14 mm	1
23	L100-500-23	Load Gear		1
24	L100-500-24-1	Drive Shaft		1
25	L100-500-25G	Gear Case Assembly		1
		Gear Case		1
		Bushing		2
		Double Seal Bearing	d12xD32x10 mm	1
26	F002118	Lock Washer	M12	3
26A	F002114	Lock Washer	M8	3
27	F001756	Lock Nut	M12	3
27A	F001754	Lock Nut	M8	3
28	L100-100-28	Rivet	3x6 mm	4
29	LM000027	Name Plate, L100-1000		1
29	LM000028	Name Plate, L100-1000 with overload		1
30	L100-500-30	Spur Gear Assembly		2
		Spur Gear		2
		Pinion Gear		2
31	L100-500-31	Load Sheave		1
31A	L100-500-31A	C-Clip	24 mm	1
31B	L100-500-31B	Needle Bearing	17x24x15 mm	1
32	L100-500-32	Guide Roller		2
33	L100-500-33	Stripper		1
34	L100-500-34	Chain Anchor Plate		1
35	L100-500-35	Chain Anchor Pin		1
36	L100-500-36	Split Pin	2x18 mm	1
37	L100-500-37	Load Chain – <i>specify length</i>	9x27 mm	1
38	L100-1000-38	Top Hook Pin		1
39	F001756	Lock Nut	M12	1
40	F005454	Socket Head Cap Screw	M12x40	2
40A	F005455	Socket Head Cap Screw	M12x45	3
41	F003084	Hex Nut	M12	5
41A	F002646	Flat Washer	M12	5
42	L100-500-42	Idle Shaft		1
43	L100-500-43	Idle Sheave		1
44	L100-1000-44	Hook Collar Assembly		2
		Steel Ball		52
		Set Screw	M12	2
47	L100-500-47	Snap Ring	32 mm	1
48	L100-500-48G	Dust Cover		1

**Note:** When ordering replacement chain (Index #12, #37), specify length.



### 13.1.10 Parts List – L100-1500 Chain Hoist (15 Ton)

Parts listed under each assembly are parts that make up that assembly (sold as an assembly only).

Index No.	Part No.	Description	Size	Qty
1	L100-1500-1	Top Hook Assembly		1
		Top Hook		1
		Safety Latch		1
		Double Spring		1
		Socket Head Cap Screw	M5x30	1
		Lock Nut	M6	1
		Top Hook Holder		1
		Hook Collar Bushing		1
		Idle Shaft		1
		Idle Sheave		2
		Needle Bearing		2
		Socket Head Cap Screw	M12x40	1
		Lock Nut	M12	2
		Lock washer	M12	2
2	L100-1500-2	Safety Latch Assembly		2
		Safety Latch		2
		Double Spring		2
		Socket Head Cap Screw	M5x30	2
		Lock Nut	M5	2
3	L100-500-3	Top Hook Shaft		1
4	L100-500-4	Split Pin	2.5x22 mm	1
5	L100-1500-5	Bottom Hook Assembly		1
		Bottom Hook		1
		Safety Latch		1
		Double Spring		1
		Socket Head Cap Screw	M6x30	1
		Lock Nut	M6	1
		Idle Shaft		1
		Idle Sheave		3
		Needle Bearing		3
		Socket Head Cap Screw		3
		Lock Nut		3
		Lock Washer		3
		Hook Collar Bushing		1
		Bottom Hook Holder		1
8	L100-500-8G	Hand Wheel Cover Assembly		1
		Hand Wheel Cover		1
		Hand Chain Guide		2
8A	L100-50-8A	Warning Label		1
9	L100-100-9-1	Wheel Stopper		1
10	L100-100-10-1	Wheel Washer		1
12	L100-100-12	Hand Chain – <i>specify length</i>	5x25 mm	2
13	L100-100-13	Hand Chain Connecting Link		2
14	L100-500-14-1	Hand Chain Wheel (5,10,20 Ton)		2
14L	L100-1500WO-14L	Overload Limiter Assembly ( <i>used on overload protection model</i> )		2
		Overload Limiter Knob		2
		Brake Disc		4
		Hand Chain Wheel		2
		Bushing in Hand Chain Wheel		2
		Disc Spring Plate		2
		Disc Spring		2
		Disc Spring Stopper		2
		Lock Nut		2
15	L100-100-15	Snap Ring	10 mm	2
16	L100-100-16	Pawl		2
17	L100-100-17	Pawl Spring		2
18	L100-500-18-1	Ratchet Disc Assembly		1
		Ratchet Disc		1
		Ratchet Bushing		1

## Parts List: L100-1500 Chain Hoist (15 Ton)

Index No.	Part No.	Description	Size	Qty
19	L100-500-19-1	Disc Hub		1
20	L100-500-20-1	Wheel Side Plate Assembly		1
		Wheel Side Plate		1
		Stay Bolt		3
		Pawl Pin		2
		Brake Cover		1
		Double Seal Ball Bearing	d35xD62x14 mm	1
21	L100-500-21	Double Seal Ball Bearing	d35xD62x14 mm	1
21A	L100-500-21	Double Seal Ball Bearing	d35xD62x14 mm	1
21B	L100-500-21B	Double Seal Ball Bearing	d12xD32x10 mm	1
22	L100-500-22	Gear Side Plate Assembly		1
		Gear Side Plate		1
		Bushing		2
		Double Seal Ball Bearing	d35xD62x14 mm	1
23	L100-500-23	Load Gear		1
24	L100-500-24-1	Drive Shaft		1
25	L100-500-25G	Gear Case Assembly		1
		Gear Case		1
		Bushing		2
		Double Seal Bearing	d12xD32x10 mm	1
26	F002118	Lock Washer	M12	3
26A	F002114	Lock Washer	M8	3
27	F001756	Lock Nut	M12	3
27A	F001754	Lock Nut	M8	3
28	L100-100-28	Rivet	3x6 mm	4
29	LM000029	Name Plate, L100-1500		1
29	LM000030	Name Plate, L100-1500 with overload		1
30	L100-500-30	Spur Gear Assembly		2
		Spur Gear		2
		Pinion Gear		2
31	L100-500-31	Load Sheave		1
31A	L100-500-31A	C-Clip	24 mm	1
31B	L100-500-31B	Needle Bearing HK1715	d17xD24x15 mm	1
32	L100-500-32	Guide Roller		2
33	L100-500-33	Stripper		1
34	L100-500-34	Chain Anchor Plate		1
35	L100-500-35	Chain Anchor Pin		1
36	L100-500-36	Split Pin	2x18 mm	1
37	L100-500-37	Load Chain – <i>specify length</i>	9x27 mm	1
38	L100-500-38	Top Hook Pin		1
38A	L100-1500-38A	Bottom Hook Pin		1
39	F003087	Lock Nut	M14	1
39A	F001755	Lock Nut	M10	1
42	L100-500-42	Idle Shaft		1
42A	L100-500-42A	Top Idle Shaft		1
43	L100-500-43	Idle Sheave		1
45	L100-1500-45	Hook Shaft		1
46	L100-1500-46	Bottom Hook Shaft		1
47A	F006070	Snap Ring	42 mm	1
47B	F006054	Snap Ring	35 mm	1
48	L100-500-48G	Dust Cover		1
52	L100-750-52	Spring Pin	8x18 mm	4
	L100-WT	Warning Tag (not shown)		1

**Note:** When ordering replacement chain (Index #12, #37), specify length.

### 13.1.11 Parts List – L100-2000 Chain Hoist (20 Ton)

Parts listed under each assembly are parts that make up that assembly (sold as an assembly only).

Index No.	Part No.	Description	Size	Qty
1	L100-2000-1	Top Hook Assembly		1
		Top Hook		1
		Safety Latch		1
		Double Spring		1
		Socket Head Cap Screw	M6x30	1
		Lock Nut	M6	1
		Top Hook Holder		1
		Hook Collar Bushing		1
		Needle Bearing	4x30 mm	1
		Idle Shaft		1
		Idle Sheave		3
		Hook Shaft		1
		Snap Ring	35 mm	2
		Snap Ring	42 mm	2
2	L100-2000-2	Safety Latch Assembly		2
		Safety Latch		2
		Double Spring		2
		Socket Head Cap Screw	M6x30	2
		Lock Nut	M6	2
3	L100-500-3	Top Hook Shaft		2
4	L100-500-4	Split Pin (5,10,20 Ton)	2.5x22 mm	2
5	L100-2000-5	Bottom Hook Assembly		1
		Bottom Hook		1
		Safety Latch		1
		Double Spring		1
		Socket Head Cap Screw	M6x30	1
		Lock Nut	M6	1
		Needle Bearing	4x20 mm	1
		Idle Shaft		4
		Idle Sheave		2
		Bottom Hook Shaft		1
		Snap Ring	35 mm	4
		Snap Ring	42 mm	2
		Hook Collar Bushing		1
		Bottom Hook Holder		1
8	L100-500-8G	Hand Wheel Cover Assembly (5,10,20 Ton)		2
		Hand Wheel Cover		2
		Hand Chain Guide		4
8A	L100-50-8A	Warning Label (all models)		2
9	L100-100-9-1	Wheel Stopper		2
10	L100-100-10-1	Wheel Washer		2
12	L100-100-12	Hand Chain – <i>specify length</i>	5x25 mm	2
13	L100-100-13	Hand Chain Connecting Link		2
14	L100-500-14-1	Hand Chain Wheel (5,10,20 Ton)		2
14L	L100-2000WO-14L	Overload Limiter Assembly ( <i>used on overload protection model</i> )		2
		Overload Limiter Knob		2
		Brake Disc		4
		Hand Chain Wheel		2
		Bushing in Hand Chain Wheel		2
		Disc Spring Plate		2
		Disc Spring		2
		Disc Spring Stopper		2
		Lock Nut		2
15	L100-100-15	Snap Ring	10 mm	4
16	L100-100-16	Pawl		4
17	L100-100-17	Pawl Spring		4
18	L100-500-18-1	Ratchet Disc Assembly		1
		Ratchet Disc		2
		Ratchet Bushing		2

## Parts List: L100-2000 Chain Hoist (20 Ton)

Index No.	Part No.	Description	Size	Qty
19	L100-500-19-1	Disc Hub		2
20	L100-500-20-1	Wheel Side Plate Assembly		2
		Wheel Side Plate		2
		Stay Bolt		3
		Pawl Pin		4
		Brake Cover		2
		Double Seal Ball Bearing	d35xD62x14 mm	2
21	L100-500-21	Double Seal Ball Bearing	d35xD62x14 mm	2
21A	L100-500-21	Double Seal Ball Bearing	d35xD62x14 mm	2
21B	L100-500-21B	Double Seal Ball Bearing	d12xD32x10 mm	2
22	L100-500-22	Gear Side Plate Assembly		2
		Gear Side Plate		2
		Bushing		4
		Double Seal Ball Bearing	d35xD62x14 mm	2
23	L100-500-23	Load Gear		2
24	L100-500-24-1	Drive Shaft		2
25	L100-500-25G	Gear Case Assembly		2
		Gear Case		2
		Bushing		4
		Double Seal Bearing	d12xD32x10 mm	2
26	F002118	Lock Washer	M12	6
26A	F002114	Lock Washer	M8	6
27	F001756	Lock Nut	M12	6
27A	F001754	Lock Nut	M8	6
28	L100-100-28	Rivet	3x6 mm	8
29	LM000031	Name Plate, L100-2000		2
29	LM000032	Name Plate, L100-2000 with overload		2
30	L100-500-30	Spur Gear Assembly		4
		Spur Gear		4
		Pinion Gear		4
31	L100-500-31	Load Sheave		2
31A	L100-500-31A	C-Clip	24 mm	2
31B	L100-500-31B	Needle Bearing	d17xD24x15 mm	2
32	L100-500-32	Guide Roller		4
33	L100-500-33	Stripper		2
34	L100-500-34	Chain Anchor Plate		2
35	L100-500-35	Chain Anchor Pin		2
36	L100-500-36	Split Pin	2x18 mm	2
37	L100-500-37	Load Chain – <i>specify length</i>	9x27 mm	2
42	L100-500-42	Bottom Idle Shaft		2
42A	L100-500-42A	Top Idle Shaft		1
43	L100-600-43	Idle Sheave		7
45	L100-600-45	Hook Shaft		1
46	L100-500-46	Bottom Hook Shaft		1
47	L100-500-47	Snap Ring	32 mm	2
47A	L100-500-47A	Snap Ring	42 mm	4
47B	L100-500-47B	Snap Ring	35 mm	6
48	L100-500-48G	Dust Cover		1
	L100-WT	Warning Tag (not shown)		1

**Note:** When ordering replacement chain (Index #12, #37), specify length.