



## 04-09 GM Colorado, Canyon Ext, Crew Cab

51-552,554

# TUBE STEP INSTALLATION SHEET

- STEP 1** REMOVE ALL PARTS FROM THE BRACKET BOX AND CHECK FOR CORRECT QUANTITY AND ANY DAMAGED PARTS.
- STEP 2** REMOVE FACTORY BODY MOUNT BOLT ASSEMBLIES. SLIDE BODY MOUNT BOLTS THROUGH BRACKETS AS SHOWN IN FIG. 1
- STEP 3** INSTALL FRONT AND REAR BRACKETS AS SHOWN, USING DESCRIBED HARDWARE, DO NOT TIGHTEN AT THIS TIME, TO ALLOW FOR FINAL ADJUSTMENTS.
- STEP 4** BOLT THE TUBE STEP TO THE BRACKET AS SHOWN USING THE DESCRIBED HARDWARE
- STEP 5** INSURE ALL PARTS ARE PROPERLY ALIGNED AND TIGHTEN ALL BOLTS. TIGHTEN THE TUBE STEP BOLTS FIRST TO 65 FT./LBS. TIGHTEN THE BRACKET BOLTS NEXT TO 35 FT/LBS.
- STEP 6** REPEAT STEPS 2 THROUGH 5 FOR INSTALLATION OF PASSENGER SIDE.

QTY	PARTS LIST	QTY	PARTS LIST
2	1550 Front Bracket	4	1/2" Lock Washer
2	1552 or 1554 Rear Bracket	4	1/2" Flat Washer
4	1/2" - 13 x 1 - 3/4" Hex Bolt	2	5/16" - 18 x 1" Hex Bolt
2	1/4" - 14 x 1" Self Tapping Screw	2	5/16" Hex Nut
2	5/16" Flat Washer	2	5/16" Lock Washer
2	3" Straps	2	Tube Steps

### **MAINTENANCE AND CARE**

Only use mild soap for regular cleaning. For heavy build up, a solution of ammonia and water can be used. Never use an abrasive material, i.e. steel wool, for cleaning purposes. Use terry cloth towels wiping in the direction of the tube at all times.

**FIG 1 Front Bracket**

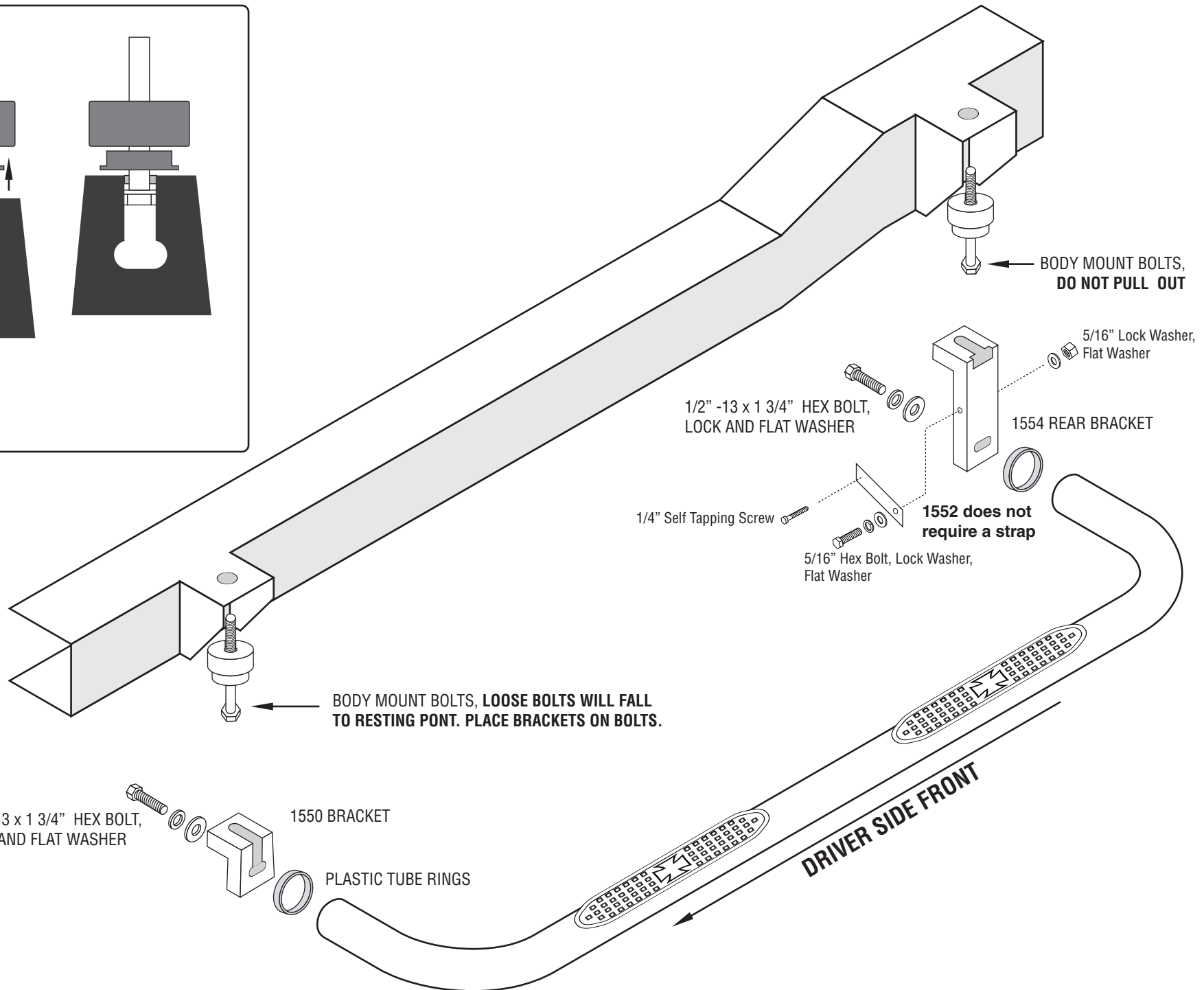
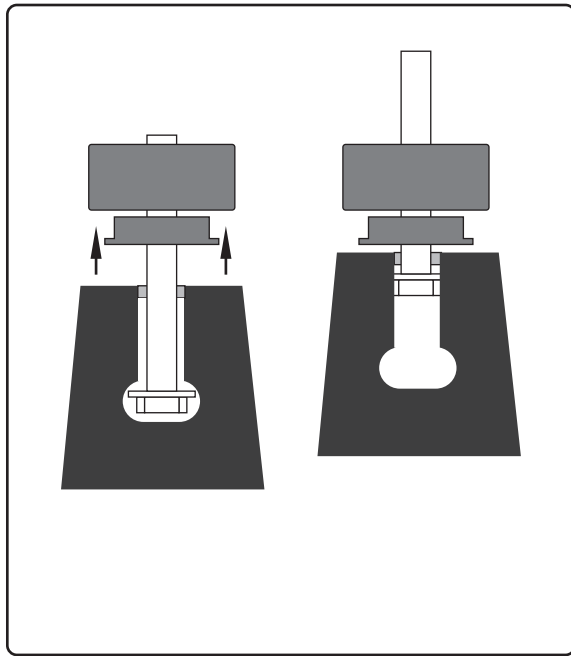

BODY MOUNT BOLTS,  
DO NOT PULL OUT

1/2" -13 x 1 3/4" HEX BOLT,  
LOCK AND FLAT WASHER

5/16" Lock Washer,  
Flat Washer

1554 REAR BRACKET

1/4" Self Tapping Screw

1552 does not  
require a strap

5/16" Hex Bolt, Lock Washer,  
Flat Washer

BODY MOUNT BOLTS, LOOSE BOLTS WILL FALL  
TO RESTING POINT. PLACE BRACKETS ON BOLTS.

1/2" -13 x 1 3/4" HEX BOLT,  
LOCK AND FLAT WASHER

1550 BRACKET

PLASTIC TUBE RINGS

DRIVER SIDE FRONT