

99-10 GM Silverado/Sierra Reg & Ext Cab
01-10 GM HD Reg, Ext, & Crew Cab
04-10 GM 1500 Crew Cab (includes Z71)

PARTS LIST * may require drilling

QTY	PARTS	QTY	PARTS	QTY	PARTS
18	8mmx40mm Bolts	6	8mm Nut Clip	4	Brackets Driver
18	5/16" Flat Washers	8	8mm Flange nuts	4	Brackets Passenger
18	5/16" Lock Washers	8	5/16" Carriage Bolts	2	Bracket Plates Rear
8	Self Tapping Bolts	8	5/16" Flange Nuts	8	Bracket Clamps

STEP 1 Remove contents from box and check for missing or damaged parts. Verify all parts are present, making sure to read and understand instructions before beginning installation.

STEP 2 07-08 Crew Cabs: Mount brackets to pinch weld and body panel.

- 1) Locate tabs on the pinchweld that have holes or factory threaded nuts in them. These tabs will line up with the factory threaded holes in the body panel.
- 2) Bolt the bracket to pinchweld hole using an 8mmx40mm hex bolt, flat washer and 8mm flange nut. *Hand tighten at this time. (Z71 - thread 8mm bolt, lock washer and flat washer into factory welded nuts on front (2) mounting points on pinch weld) FIG 2*
- 3) Bolt the top of the front (2) brackets on by inserting a 8mm x 40mm hex bolt, lock washer and flatwasher through bracket slot and into the factory threaded holes. **FIG 3**
- 4) Remove (2) rubber plugs on rear mounting positions.
- 5) Insert 8mm nut clips into rear hole mounting positions. **FIG 4**
- 6) Thread a 8mm x 40mm hex bolt and 5/16" flat washer through top bracket slot into nut clip. *Rear bracket will require **bracket plate** between bracket and sidewall. FIG 4*

07-08 Reg & Ext Cabs - Will not have factory threaded holes, use nut clips in holes at all bracket mounting locations.

STEP 3 *99-06 Crew Cabs: Mount brackets to pinch weld and body panel.



- 1) Locate tabs on the pinchweld. Some may have have factory punched oblong holes in them. The front (2) tabs will line up with the factory threaded holes in the panel. The tabs will have to be drilled to allow for a bolt hole. Oblong holes may be too narrow for supplied 8mm bolt and therefore must be widened with drill.
- 2) Bolt the bracket to pinchweld hole using an 8mmx40mm hex bolt, flat washer and 8mm flange nut. *Hand tighten at this time.*
- 3) Bolt the top of the front (2) brackets on by inserting a 8mm x 40mm hex bolt, lock washer and flatwasher through bracket slot and into the factory threaded holes.
- 4) The top of the rear two brackets will have to be installed with self tapping bolt and lock washer. Use the small hole next to the vertical oblong hole at top of bracket. Start with drill and then hand tighten to make snug.

STEP 4 *99-08 Reg & Extended cabs: Mount brackets to pinch weld and body panel.



- 1) Locate tabs on the pinchweld. Choose mounting points and drill 5/16" hole in center of tabs.
- 2) Bolt the bracket to pinchweld hole using an 8mmx40mm hex bolt, flat washer and 8mm flange nut. *Hand tighten at this time.*
- 4) The top of the brackets will have to be installed with self tapping bolt and lock washer. Use the small hole next to the vertical oblong hole at top of bracket. Start with drill and then hand tighten to make snug.

MOUNTING BRACKET TO TRUCK

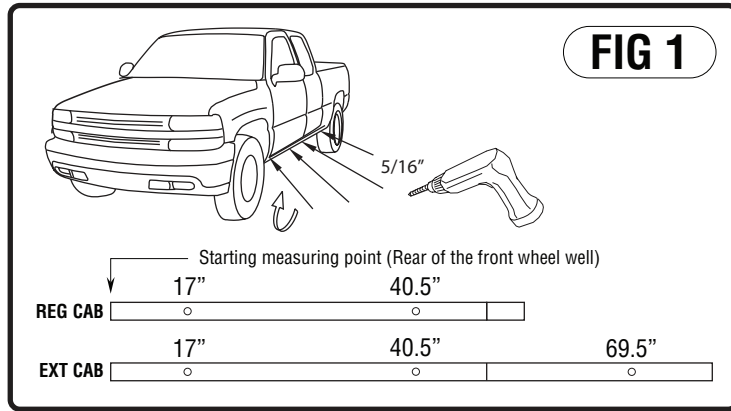

Use self tapping bolt here if no holes in body panel.

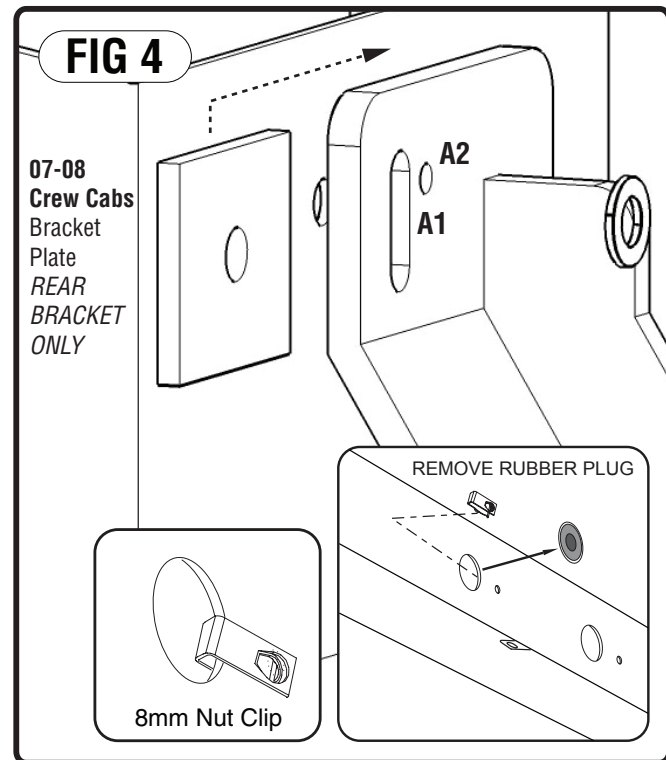
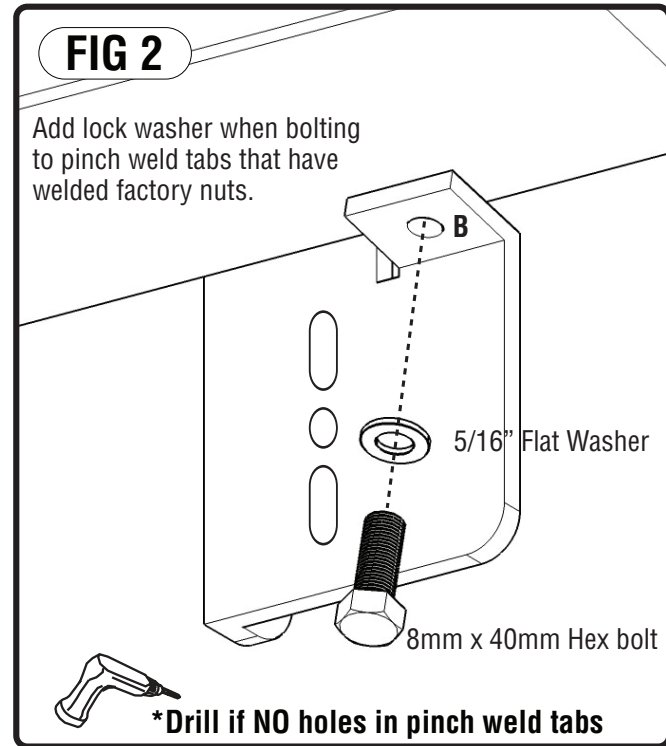
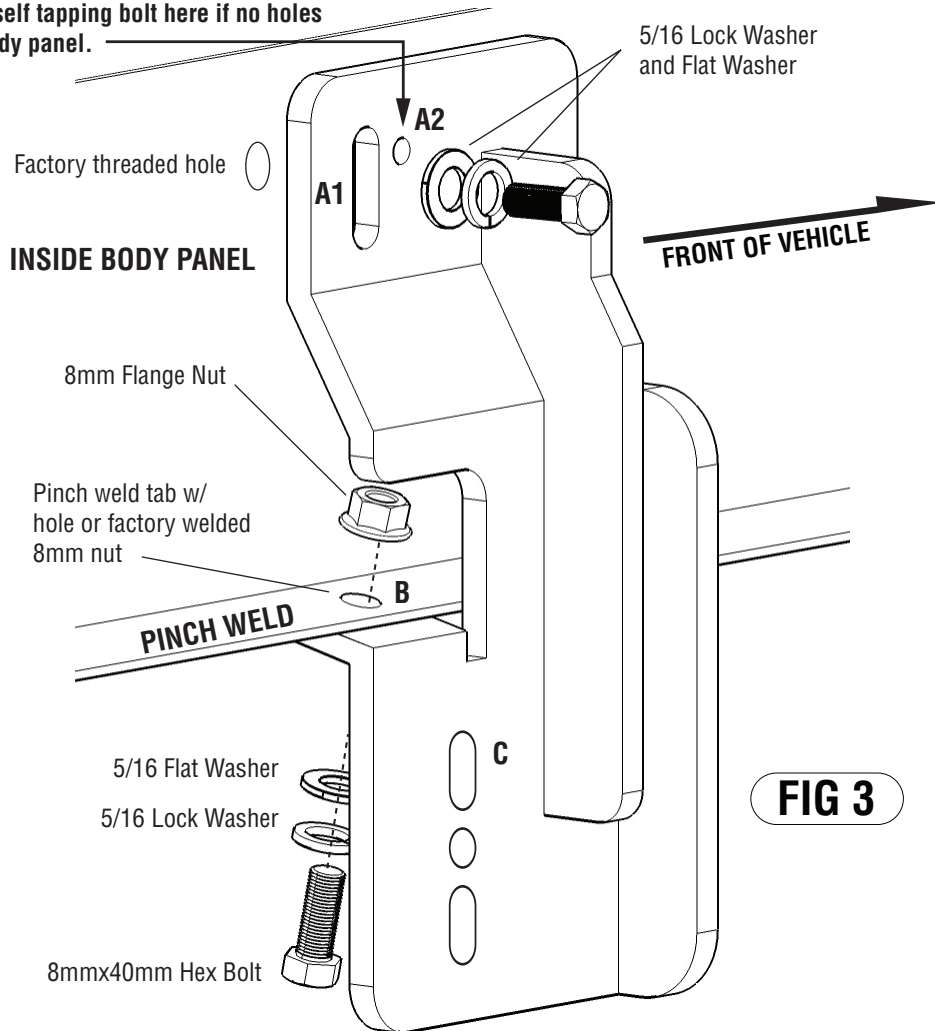

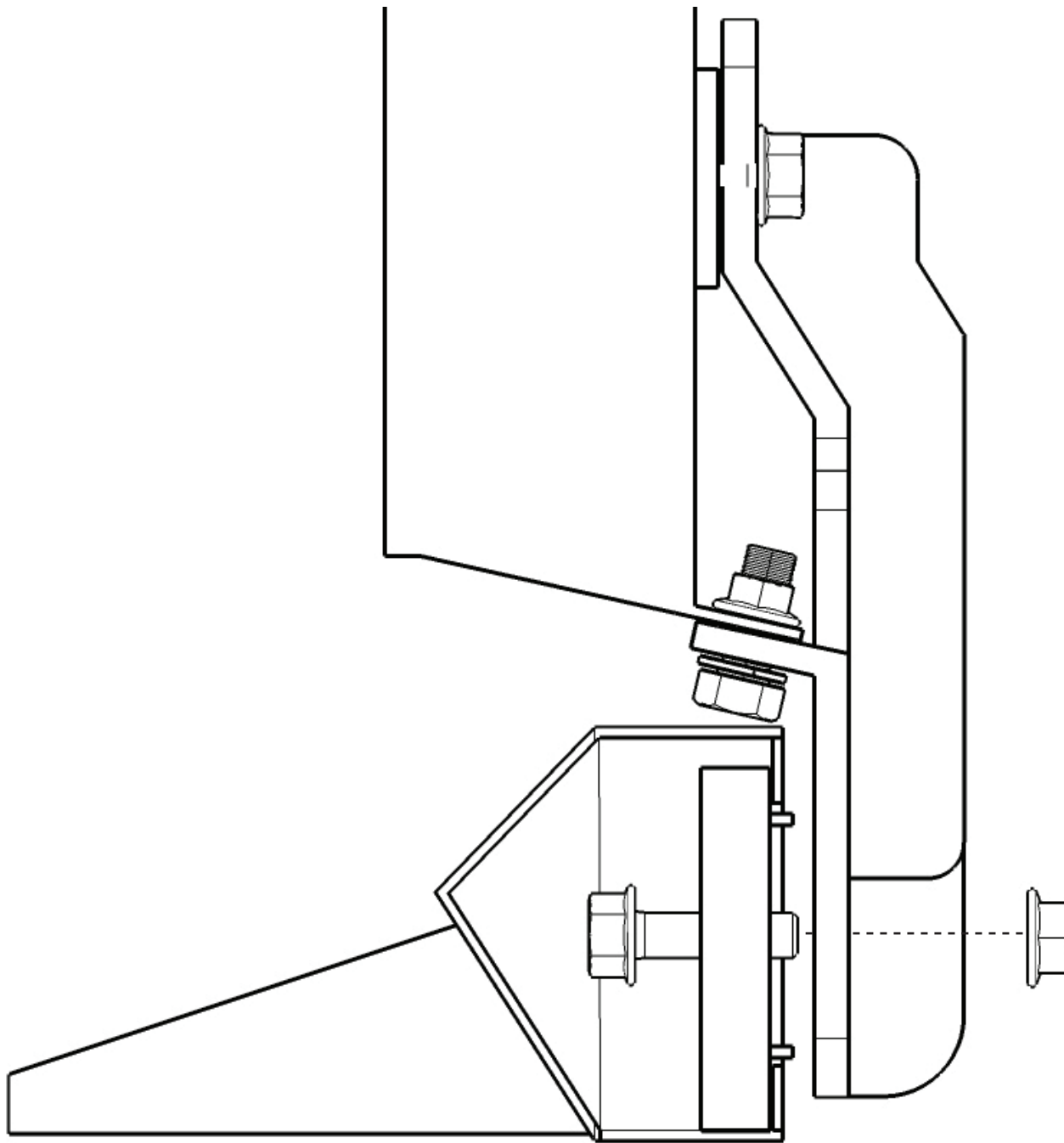

HD STEP INSTALL

1. Install 5/16" hardware and "bracket clamp" to each bracket through hole "C". Having a second person or jack stands will be helpful on install.
2. CAREFULLY place HD STEP over bracket clamps and align so that clamp tabs are in between step channel. Begin to hand tighten 5/16" flange nuts while making sure bracket clamp tabs are aligning to the bracket holes.
3. Once you have all clamps hand tightened to brackets, this should allow the HD STEP to slide forward and back to allow for final alignment to vehicle.
4. Once satisfied with alignment, tighten all 5/16" flange nuts for final install.