



09-10 F-150 Super Cab and Super Crew

51-466,468

TUBE STEP INSTALLATION SHEET

- STEP 1** REMOVE ALL PARTS FROM THE BRACKET BOX AND CHECK FOR CORRECT QUANTITY AND ANY DAMAGED PARTS.
- STEP 2** INSTALL THE FRONT BRACKET BY INSERTING THE NUT CLIPS INTO THE BODY PANEL. REMOVE THE TAPE IN FRONT OF THE HOLES AND INSERT IN THE FRAME LOCKER AS SHOWN IN ILLUSTRATION. BOLT UP THE BRACKET USING THE HARDWARE DESCRIBED IN THE ILLUSTRATION. HAND TIGHTEN AT THIS TIME ALLOWING FOR FINAL ADJUSTMENTS.
- STEP 3** INSTALL THE REAR BRACKET BY REMOVING THE TAPE ON THE REAR HOLE ON THE INNER BODY PANEL (LAST REAR BOLT LOCATION SHOULD HAVE NO TAPE COVERING HOLE). INSERT THE 3/8" FRAME LOCK BOLT AND 1/2" BOLT INTO REAR HOLES AS SHOWN IN ILLUSTRATION. HAND TIGHTEN AT THIS TIME TO ALLOW FOR FINAL ADJUSTMENT. DON NOT USE THE SELF TAPPING SCREWS AT THIS TIME.
- STEP 4** BOLT THE TUBE STEP TO THE BRACKETS AS SHOWN USING THE DESCRIBED HARDWARE. BOLT THE TUBE TO THE FRONT BRACKET FIRST.
- STEP 5** INSURE ALL PARTS ARE PROPERLY ALIGNED AND TIGHTEN ALL BOLTS. TIGHTEN THE TUBE STEP BOLTS FIRST TO 65 FT./LBS. TIGHTEN THE BRACKET BOLTS NEXT TO 35 FT./LBS.
- STEP 6** REPEAT STEPS 2 THROUGH 5 FOR INSTALLATION OF PASSENGER SIDE.

QTY	PARTS LIST	QTY	PARTS LIST
6	1/2" BOLTS	4	5/16" SERRATED FLANGE BOLTS
8	1/2" FLAT WASHERS	4	5/16" HEX BOLTS
6	1/2" LOCK WASHERS	4	5/16" FLAT WASHERS
4	3/8" FRAME LOCKS	4	5/16" SERRATED FLANGE NUTS
4	5/16" NUT CLIPS	2	1/2" NUT

MAINTENANCE AND CARE

Only use mild soap for regular cleaning. For heavy build up, a solution of ammonia and water can be used. Never use an abrasive material, i.e. steel wool, for cleaning purposes. Use terry cloth towels wiping in the direction of the tube at all times.

VIEW OF PASSENGER FRONT BRACKET

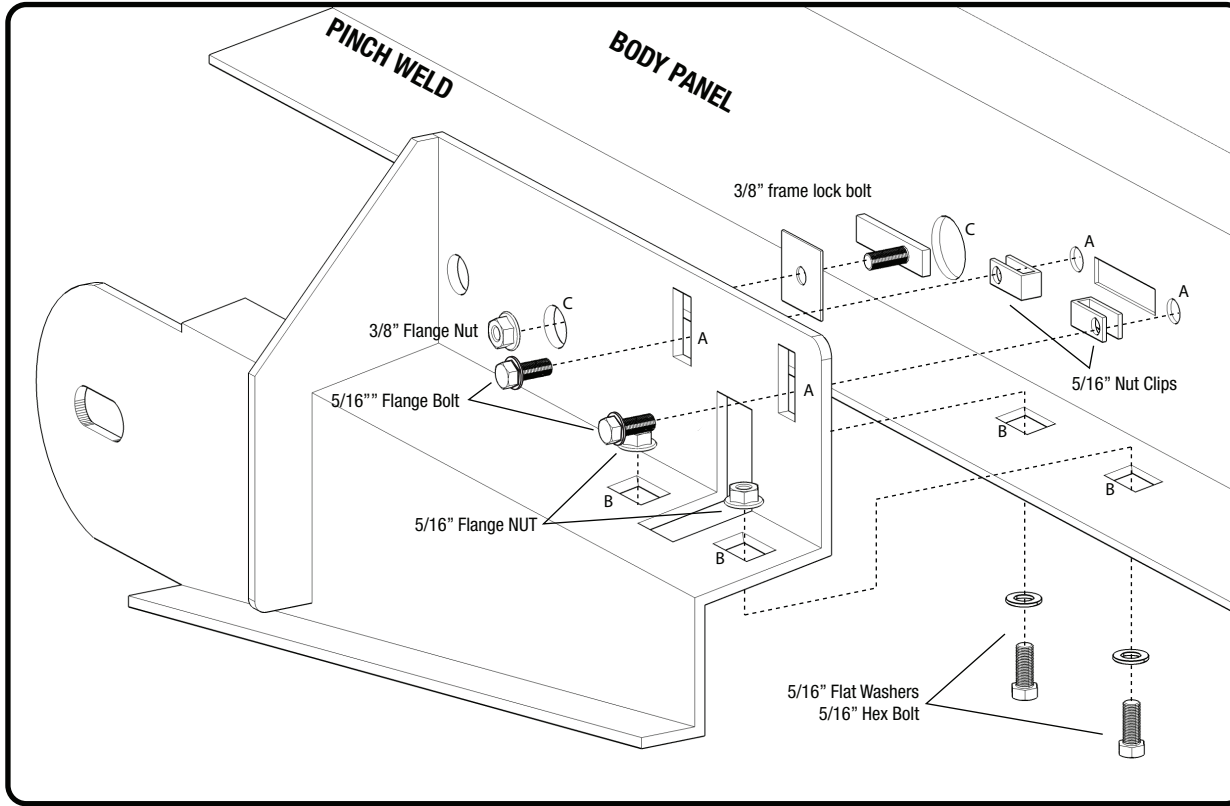

FRAME LOCK BOLT INSTALL

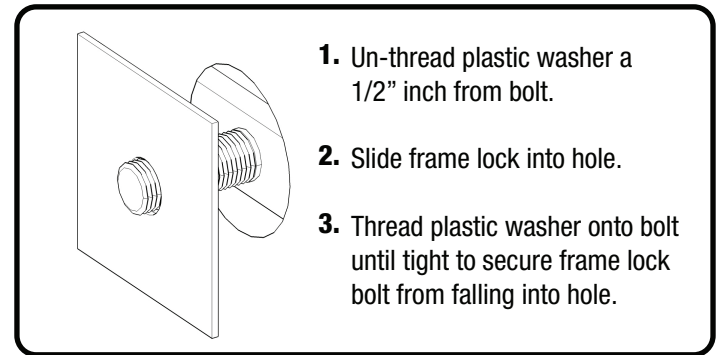

NUT CLIP INSTALL

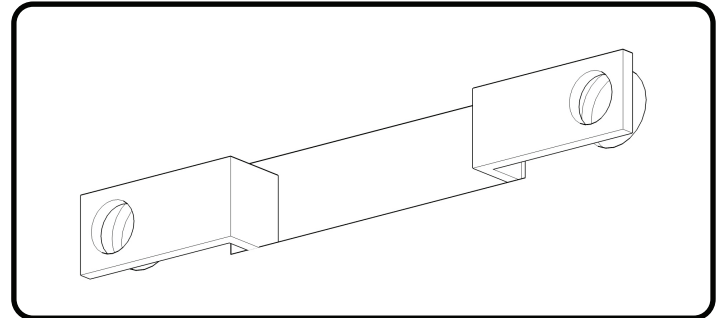

VIEW OF DRIVER REAR BRACKET

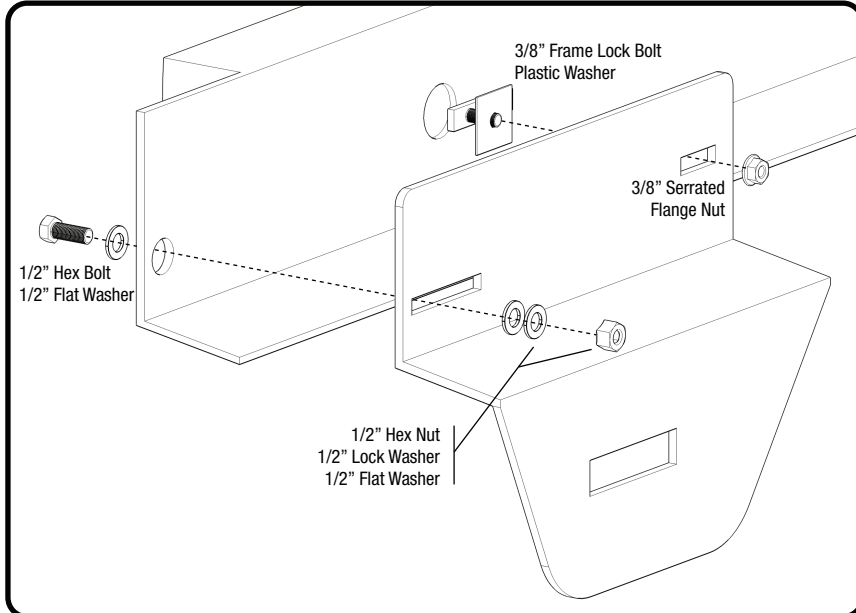

TUBE TO BRACKET INSTALL

