

PARTS LIST

QTY	PARTS	QTY	PARTS
12	5/16" X 1.25" Hex Bolt	6	Brackets
12	5/16" Flange Bolt	12	3/8" Flange Bolt
24	5/16" Flat Washer	6	Double Rail Tabs
12	5/16" Flange Nut	12	5/16" Nut Clip

BRACKET INSTALLATION

- 1) Remove contents from box and check for damaged parts. Verify all parts are present, making sure to read and understand instructions before install.
- 2) Locate factory holes on inside body panel and pinchweld. **Fig 1** Regular Cabs have 2 mount locations, Super Cabs and Crew Cabs have 3.
- 3) Install nut clip into factory location. **Fig 2**
- 4) Position the bracket to the pinch weld holes. Install 5/6" hex bolt and 5/16" flat washer through pinch weld and holes "B" on bracket. Thread 5/16" flange nut onto hex bolt and tighten. **Fig 3**
- 5) Install 5/16" flange bolt through holes "A" on bracket into nut clips and tighten. **Fig 3**
- 6) Repeat install on passenger side.

TUBE AND RAIL INSTALLATION *(Tubes and rails are not driver and passenger side specific. They fit both sides universally)*

- 1) Tube and rail come preassembled in box. Unassemble tube and rail before install. You may loosen hex bolt and slide rail from tube leaving hex bolt and rail tab on the tube brace.
- 2) Insert 3/8" hex bolt into hole "C" of front bracket and loosely thread rail-tab to bolt a few turns. Slide rail onto rail-tabs. *Hand tighten at this time.* **Fig 4**
- 3) Slide middle bracket rail-tabs into rail and then attach rail to REAR bracket with 3/8" hex bolt and rail-tab. **Fig 4**
Hand tighten at this time.
- 4) Hold middle rail-tabs with fingers to thread 3/8" hex bolt through bracket into tab and tighten. *Hand tighten at this time.*
- 5) With 3/8" hex bolt and rail-tab fixed to TUBE BRACE, side onto bottom side of rail at near the rear bracket. **Fig 5**
- 6) Attach front of tube to rail by sliding rail-tab in to position and threading 3/8" hex bolt through tube brace. *Hand tighten at this time.*
- 7) Push up on rail when making final adjustments. TIGHTEN ALL REMAINING BOLTS TO COMPLETE INSTALL. 40 FT LBS. MAX TORQ

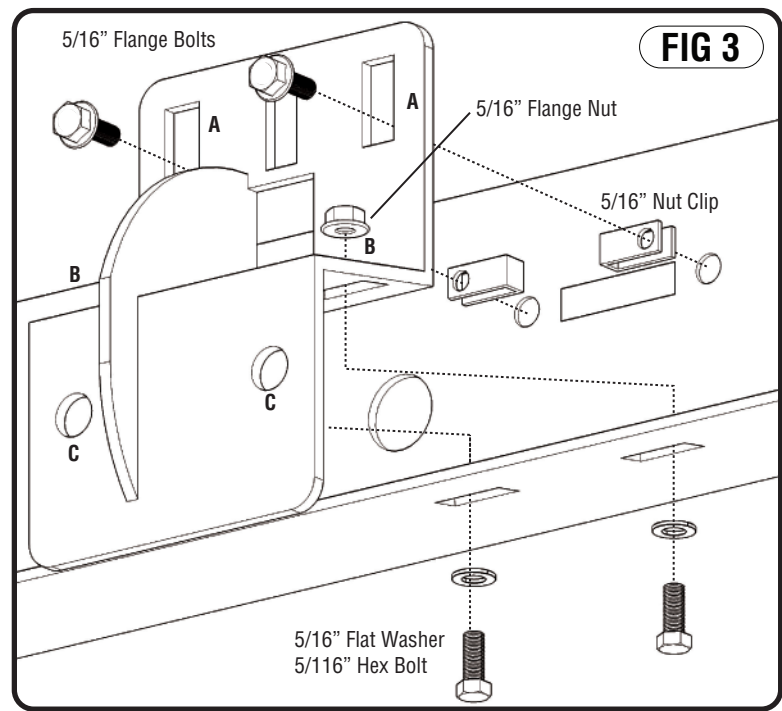
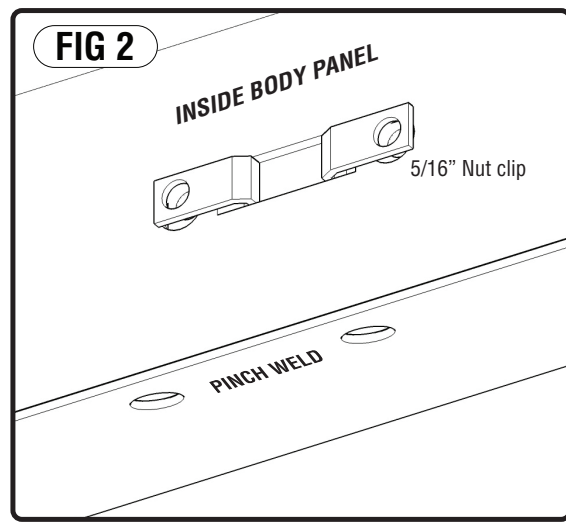
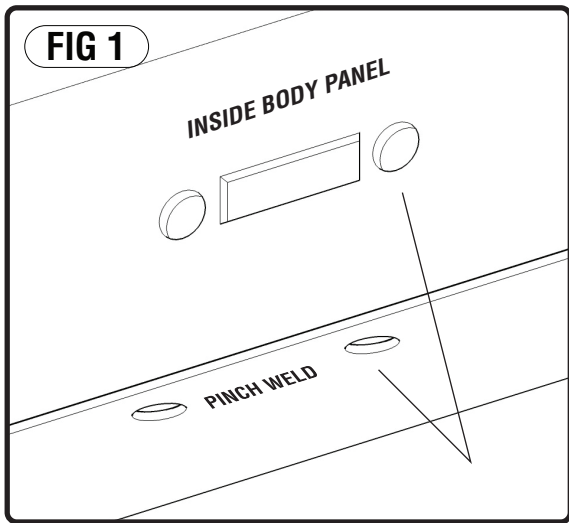

When making final adjustments, we recommend tube to be placed 2-3 inches from the rear of the FRONT wheel well.

Rail should be centered to tube. (1" past inner hole of tube or 5" from tube ends)

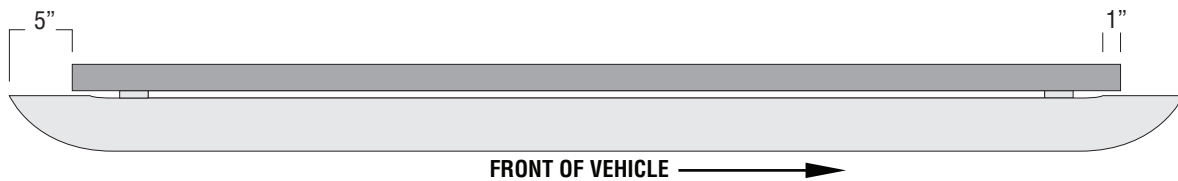

09 F-150 Middle bracket install: Use (1) nut clip and flange bolt for center hole mount.

