

IRON CROSS AUTOMOTIVE INC.

INSTALLATION INSTRUCTIONS FRONT WINCH BUMPER

20/22/24-425-08

11-14 FORD 250/350/450



PARTS LIST

14	1/2" Hex bolt
14	1/2" Hex Nut
28	1/2" Flat Washer
14	1/2" Lock washer
1	Driver bracket
1	Passenger bracket

STEP 1. BUMPER REMOVAL

A. DISCONNECT FACTORY FOG LAMP CONNECTORS AND ZIP-TIE TO FRAME

B. LOOSEN BOLTS HOLDING OEM BUMPER TO FRAME

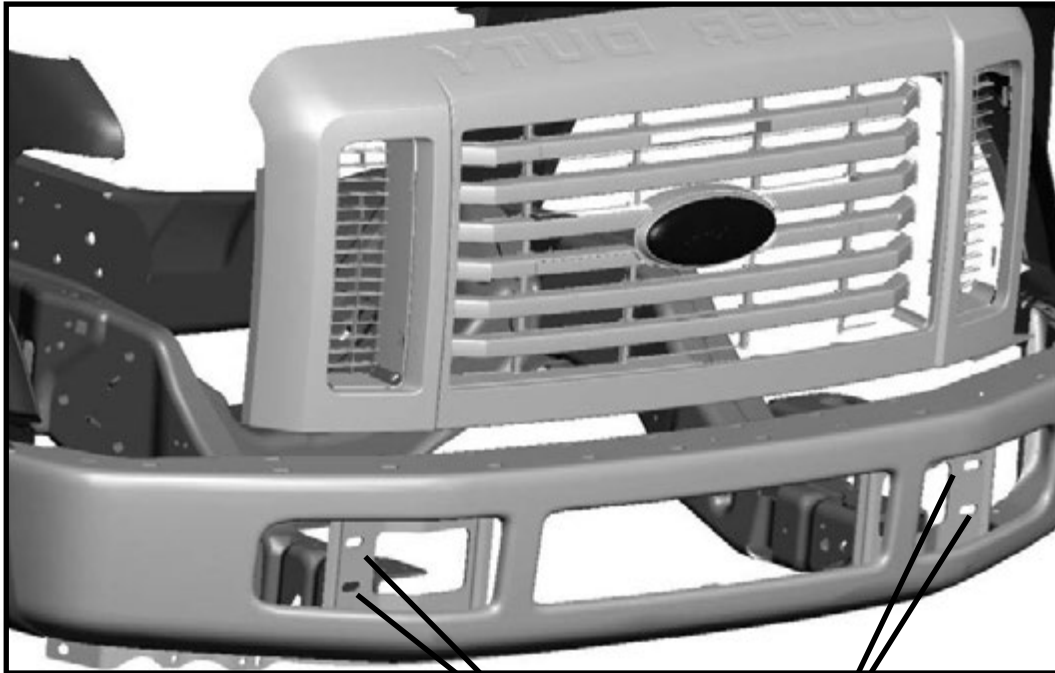

REMOVE BOLTS

C. REMOVE FASTNER HOLDING HOOD RELEASE LEVER TO OEM FRONT BUMPER.



D. REMOVE FRONT BUMPER REAR BRACE BOLTS

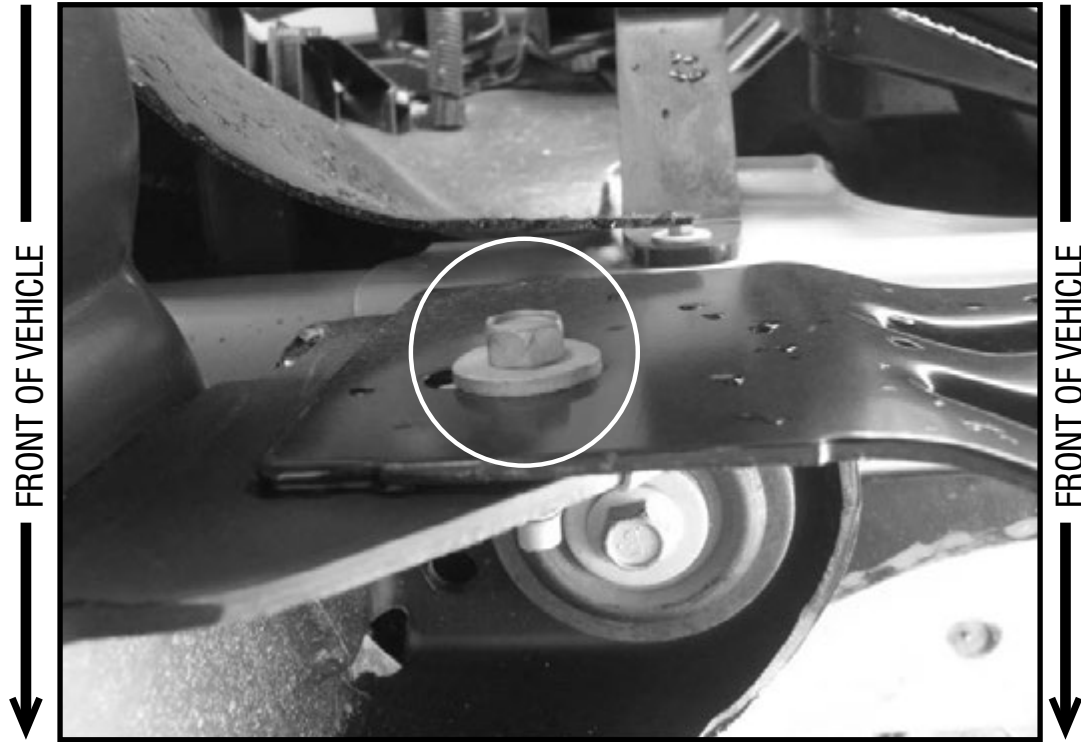

STEP 2. TOW HOOK REMOVAL

A. LOOSEN AND REMOVE (3) BOLTS.

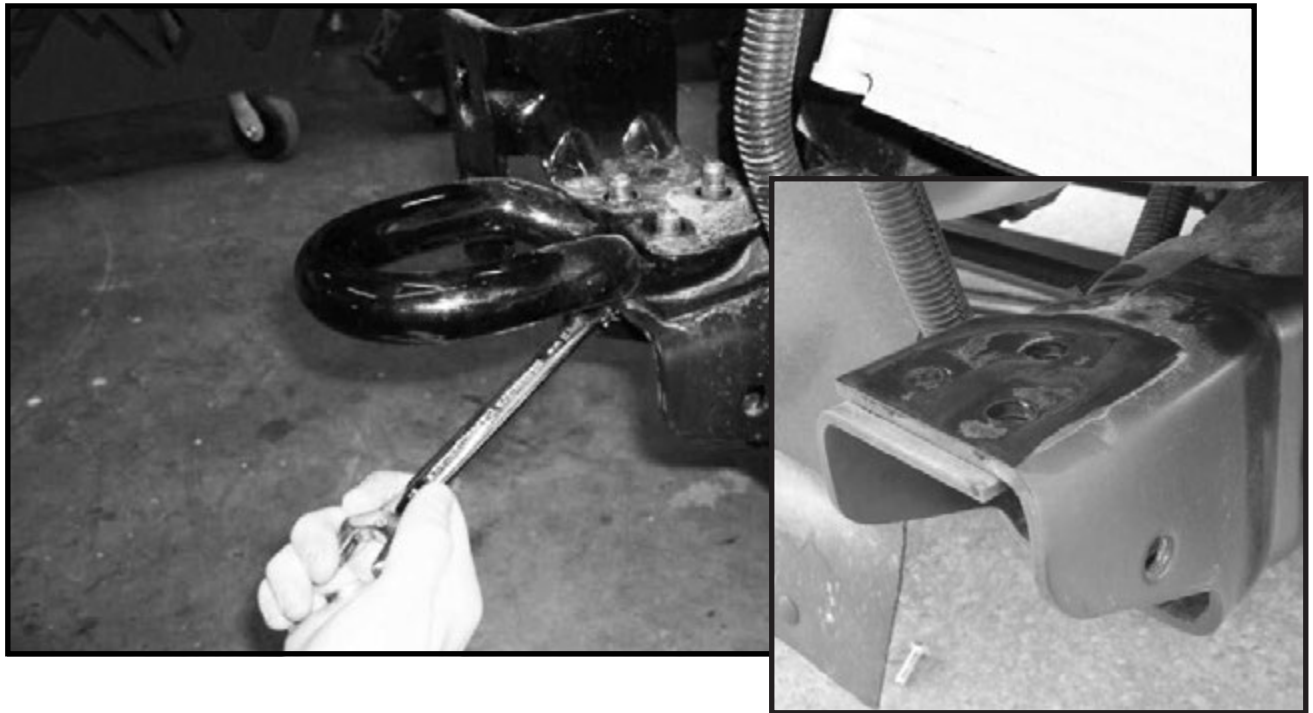

STEP 3. BUMPER BRACKET INSTALL



A. PLACE BUMPER BRACKET TO FRAME.



B. INSTALL HARDWARE AS SHOWN.

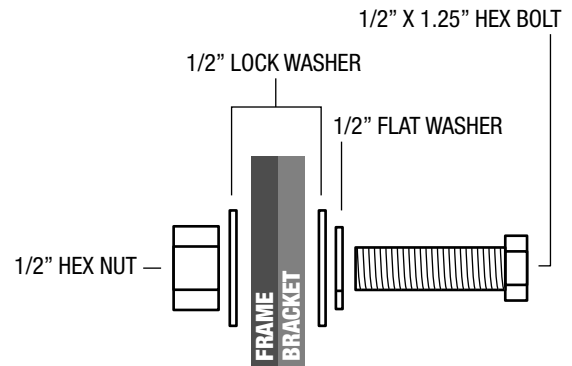

C. REPEAT INSTALLATION FOR PASSENGER SIDE. HAND TIGHTEN HARDWARE AT THIS TIME FOR ADJUSTMENT AT FINAL INSTALL.

STEP 4. BUMPER INSTALL



- A. ALIGN BUMPER MOUNTING HOLES (A,B,C) TO BUMPER BRACKET HOLES (A,B,C).
- B. INSTALL HARDWARE AS SHOWN. HAND TIGHTEN HARDWARE AND LEAVE LOOSE TO MAKE ANY ADJUSTMENTS.
- C. ONCE SATISFIED WITH ALIGNMENT, TIGHTEN BOLTS DOWN FOR FINAL INSTALL.



INSTALL HARDWARE AS SHOWN.

