

American Made = American Jobs

IRON CROSS AUTOMOTIVE INC.

21-515-88 88-98 Chevy/GMC 1500/2500/3500

21-515-99 99-06 Chevy/GMC 1500

21-515-07 07-13 Chevy/GMC 1500

21-525-03 03-06 Chevy/GMC 2500/3500

Installation Instructions

Tools Required

- Socket wrench with extension
- 3/4", 15MM, 18MM, & 22MM sockets
- 3/4", 15MM, 18MM, & 22MM box end wrench
- Regular screw driver
- Floor jack and wood block

Hardware

4	1/2" Hex Bolt	4	1/2" Lock Washer
8	1/2" Flat washers	4	1/2" Hex Nut
2	Tag Lights		

Vehicle Preparation

1. A) Remove license plate, and OEM license plate lights. If so equipped, unplug back-up sensors and seal OEM connector with tape; affix to frame.

B) Remove OEM bumper fasteners and OEM bumper. Set aside (**Fig 1**).

C) Remove OEM spare tire access cover from bumper. Set aside.

Inside view of passenger side.

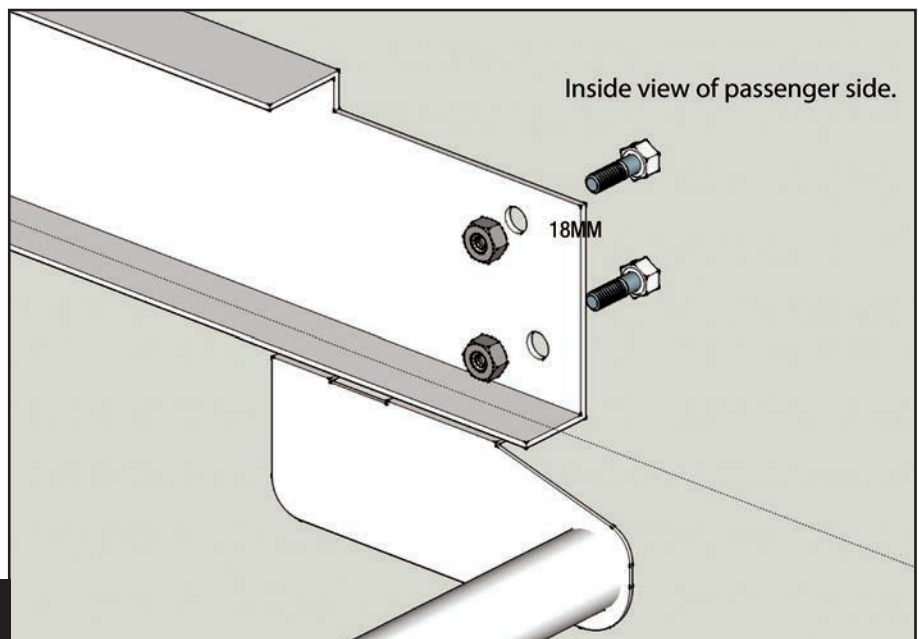

Fig 1



IRON CROSS AUTOMOTIVE

Bumper Install

- 2. A) Bolt bumper to frame using supplied hardware: bolts, washers, and nuts. Repeat for other side. Align spare tire access cover with guide tube (**Fig 2**).
- B) Align bumper front to back and tighten frame mount fasteners.
- C) Align bumper height side-to-side, verify tailgate clears while lowered, and tighten bumper mounting fasteners using 3/4" socket and wrench.
- D) Plug in license plate light harness and secure to frame rails.
- E) Re-install license plate.

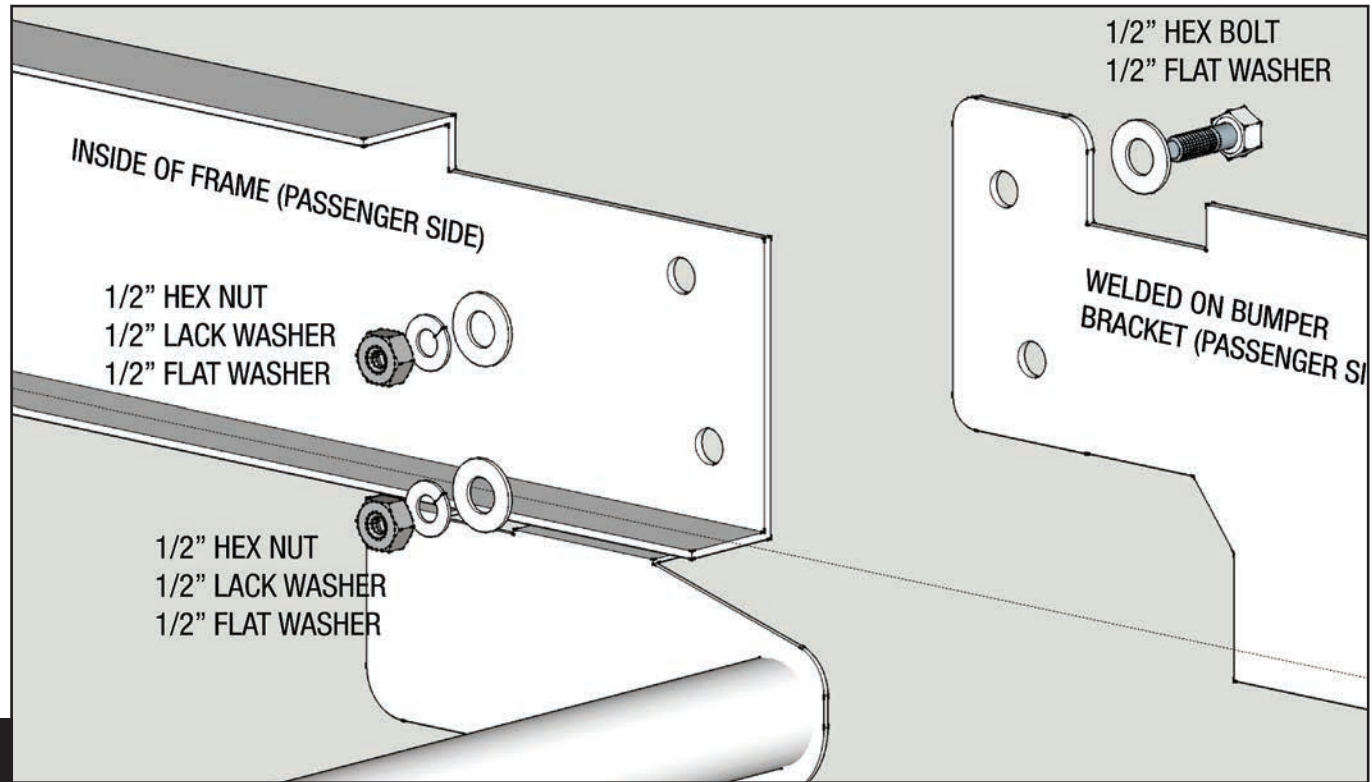

Fig 2



IRON CROSS AUTOMOTIVE

Tag Light Wiring

3. Factory tag lights must be cut and replaced with replacement tag lights (**Fig 3**).

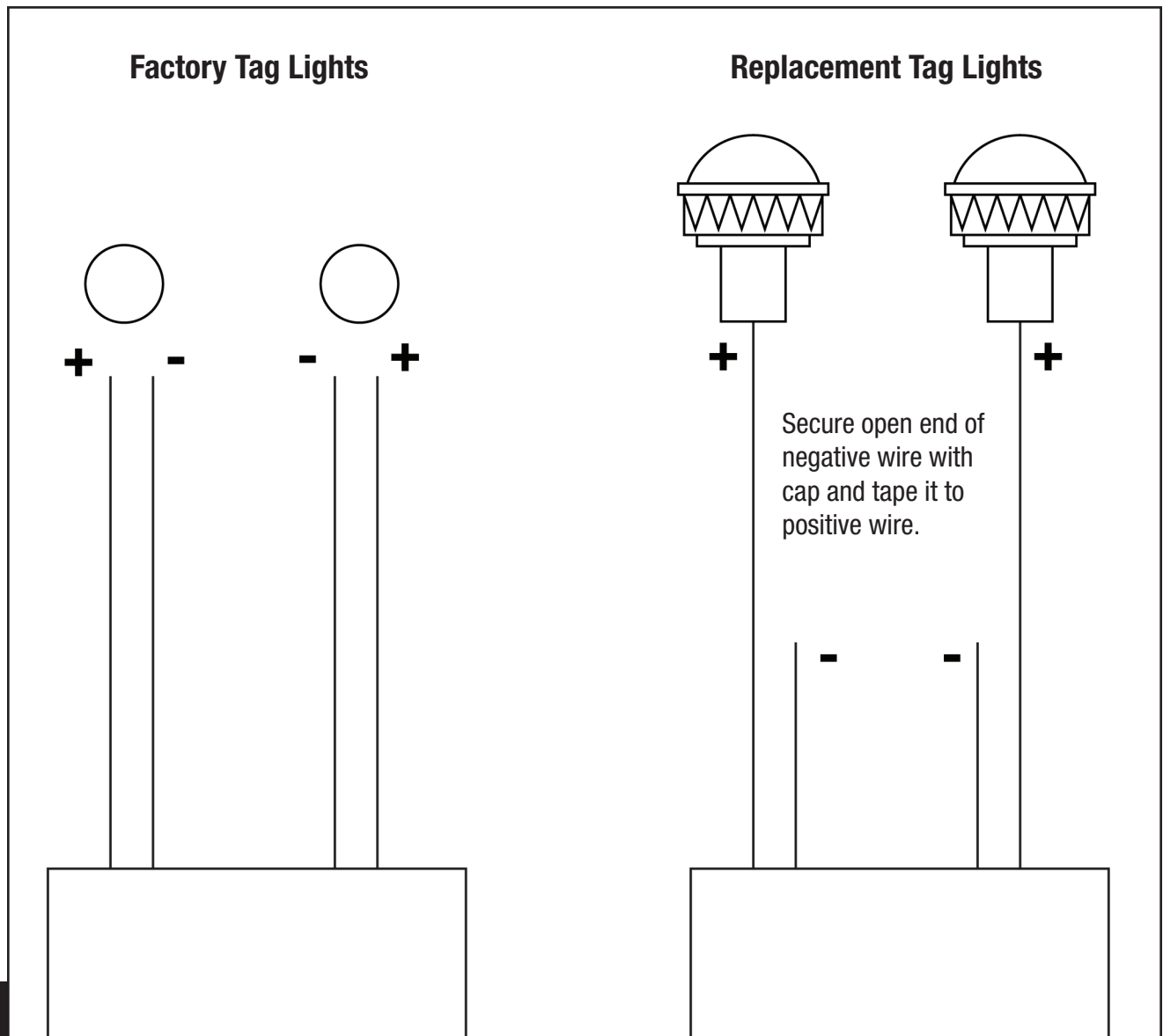

Fig 3



IRON CROSS AUTOMOTIVE