

American Made = American Jobs

IRON CROSS
AUTOMOTIVE INC.

07-13 Toyota Tundra
20-715-07

07-13 Toyota Tundra
30-715-07

Installation Instructions

Hardware	
12	½" Flat Washers
6	½" Lock Washers
6	½" Hex Bolts
6	½" Hex Nuts
1	Driver Side Bracket
1	Passenger Side Bracket

This product is for off road use only. All liability for installation and use rests with the owner.

Careless installation and operation can result in serious injury or equipment damage.

Stock Bumper Removal

A) Using a cross tip screw driver, remove the (3) screws from the bottom plastic mold of bumper. **Fig. 1**

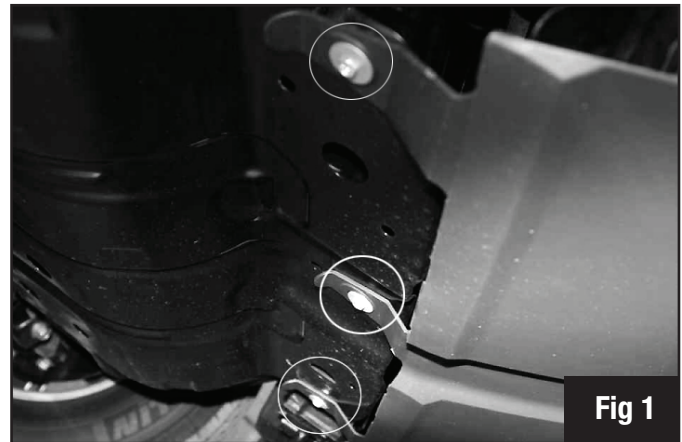

Stock Bumper Removal

B) Remove dart clip from inner fender lining from the frame on both sides. **Fig 2.**

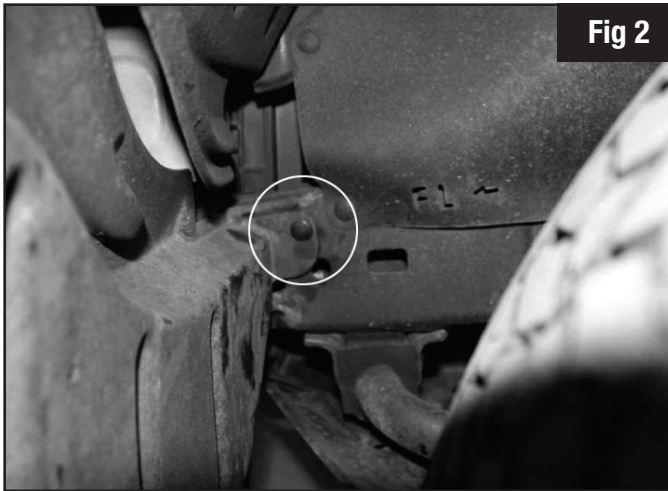

C) Disconnect the factory fog light harness from the fog lights and secure harness out of harms way and to the frame.

D) Remove the factory tow hooks (2 bolts per tow hook) using a 17MM socket and wrench.

E) Remove dart clips and plastic splash guard. See **Fig 6.**

F) Disconnect factory fog lamp connectors. **Fig 3.**



G) Remove the 2 Phillips head screws located in the inner fender well lining, per side. **Fig 4.**

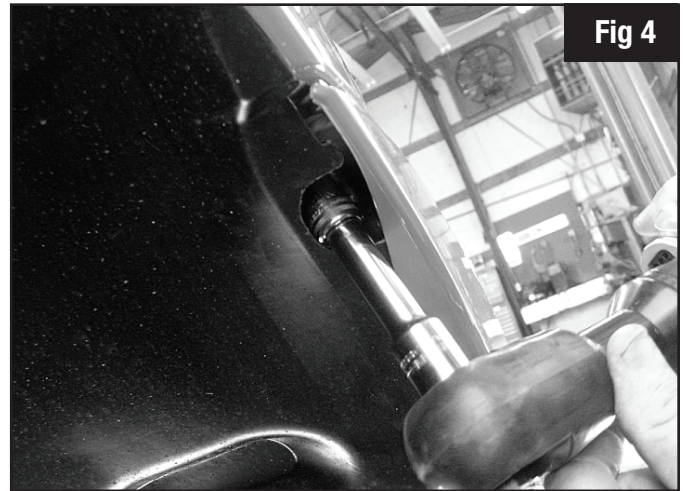

H) Remove dart clips from corner cap. **Fig 5.**



I) Remove corner cap. Do not break corner cap studs that fit in holes. **Fig 6.**

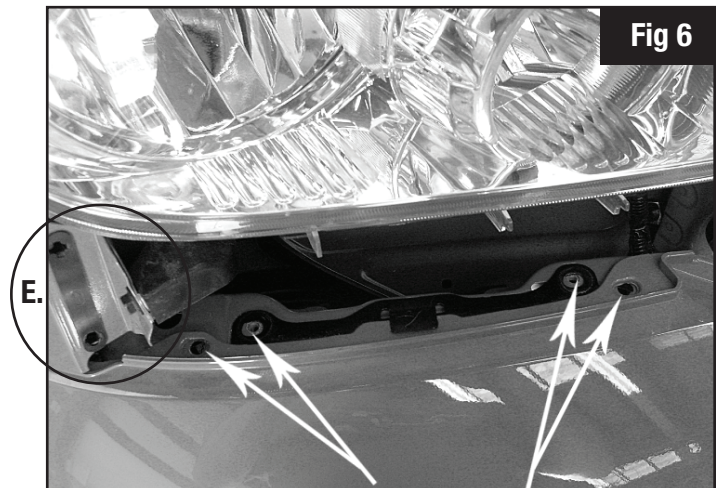

J) Remove bolts on bumper mold below the corner cap, (4) on each side. **Fig 6.**



Stock Bumper Removal Continued...

K) Remove (8) 10MM bolts from center of plastic bumper mold. **Fig 7.**

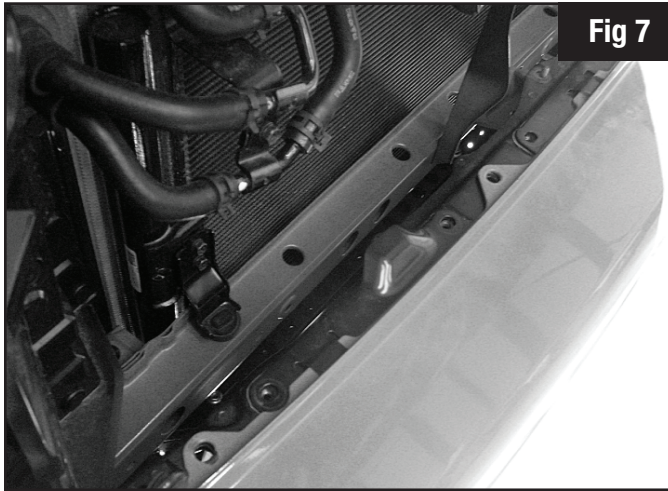

L) Remove the Phillips pop rivet holding the fascia to the inner fender, (1) per side.

M) Pull the edges of the plastic fascia from the truck and directly away from the front to snap free. Set mold aside.

N) Using a deep 14MM socket and breaker bar, loosen the (4) 14MM nuts located at the connection between the factory frame end and the bumper.



O) Remove and pull bumper directly away from truck.

****DO NOT perform this step for RS series bumpers. ****

P) Remove the two 10MM screws using a socket from the plastic spacer pieces located on the lower fender. With screws removed, pull bracket straight off the truck complete on opposite side. **Fig 9.**

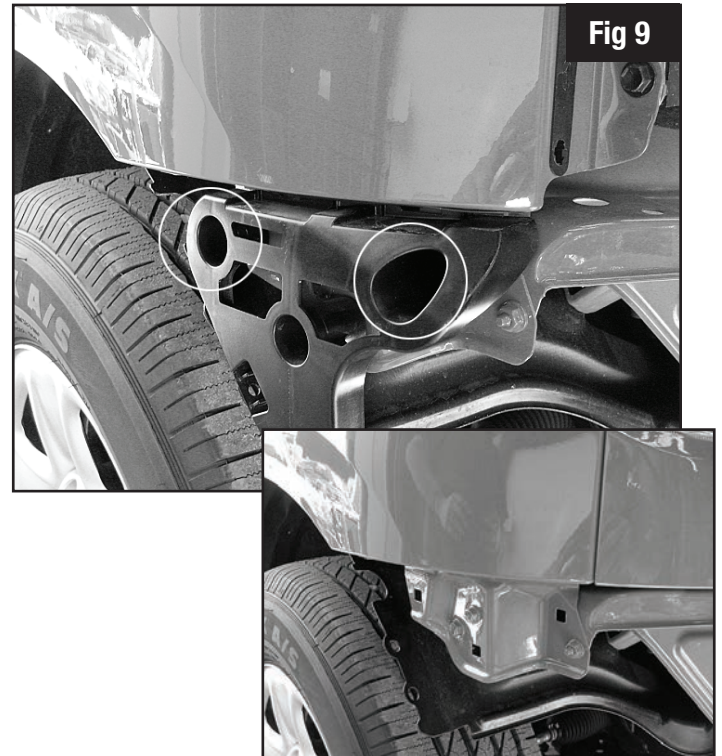

Q) Remove front upper center bumper retainer (cross member) and both right and left front bumper end retainers. **Fig 10.**

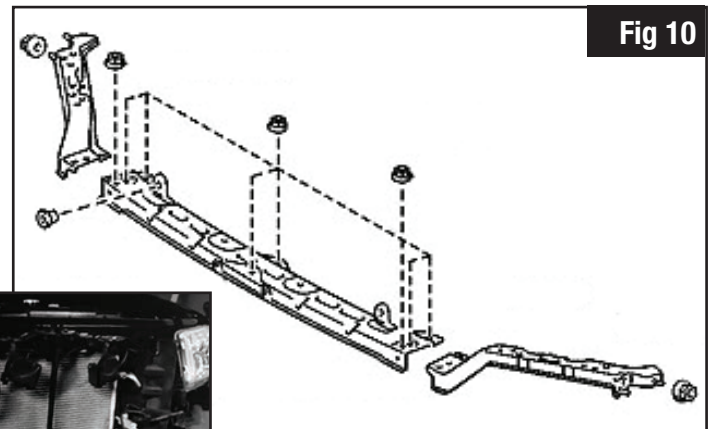

** Inset photo shows front upper center bumper retainer (cross member) and both right and left front bumper end retainers already removed.*

Bumper Installation

A) Using the OEM hardware, install the intermediate mounting brackets to the frame.

This requires the (4x) 14MM nuts and (2x) 17MM bolts previously used on the tow hook(s) per side. Do not tighten fully. Only finger tighten to allow for adjustment. **Fig 11 & Fig 12.**

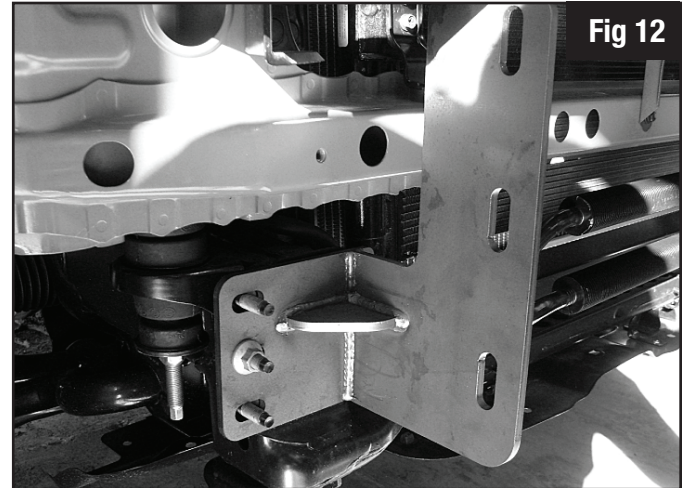
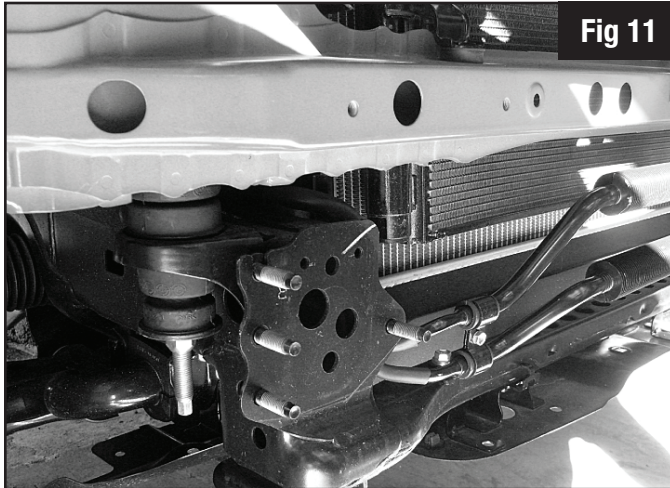

B) Carefully align bumper mount towers with intermediate mounts and slide bumper into place. Install the supplied 1/2" mounting bolts but do not tighten fully. It may be helpful to support bumper with a floor jack during install. Repeat for other side. This will require a minimum of two people to hold the bumper and a third person to install the supplied hardware.

C) Adjust the bumper to achieve accurate visual alignment as follows:

- 1) Adjust "castor" with mounting bracket bolts.
- 2) Adjust in/out, up/down, and left/right with the intermediate mounting bolts. Allow .5" gap from all painted surfaces for frame flex.
- 3) Tighten all fasteners - beginning with frame mounts. Then tighten all mount-to-bumper fasteners. **Fig 13.**

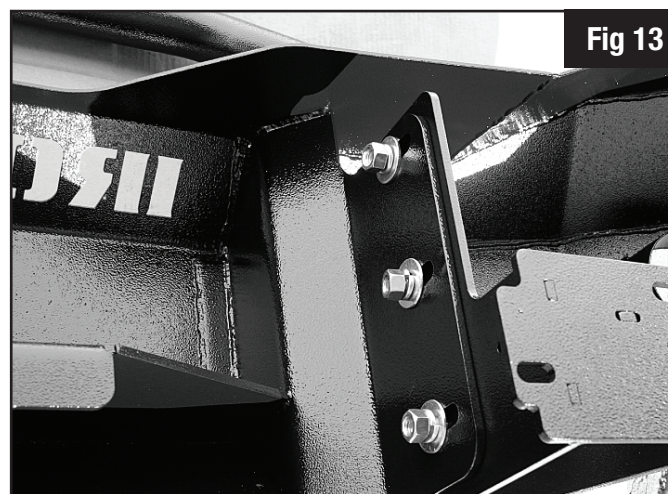

RS Series Bumper Installation

A) Reinstall factory front components that hold on the lower grill valance and plastic pieces beneath the headlights. Perform steps L-G, in that order.

Then reinstall bracket on the lower grill valance.

B) Using the OEM hardware attach your New Iron Cross brackets to the frame. Hand tighten at this time to allow for final adjustment. Brackets should have just over 28" of space between them. Fig 14.

C) Slide your new Iron Cross RS bumper between the brackets and attach with supplied 1/2" hardware. Adjust bumper up and down and in and out, leaving 1/2" between any factory panels. Tighten to 60 ft/lb.

D) Adjust the bumper side to side and tighten the nuts holding the brackets to the frame.

E) Reinstall inner wheel well splash guards and trim as necessary.

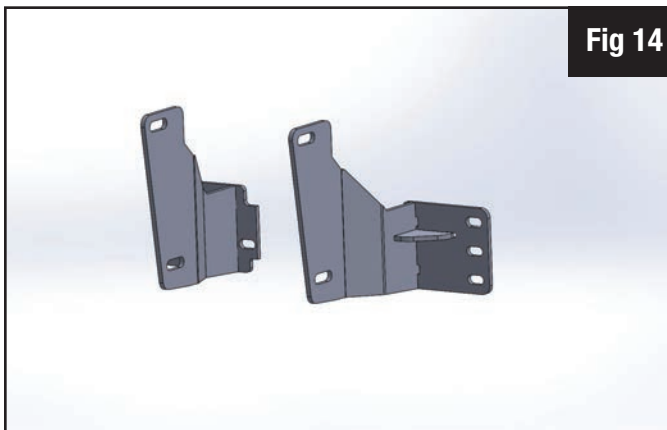

Fig 14

Aftermarket 4" lights are not supplied with bumper.

USE THE FOLLOWING DIAGRAM TO INSTALL AFTERMARKET 4" LIGHTS (SOLD SEPERATELY)

OEM Wiring Diagram

Driver Side Turn Indicator at Headlight
OEM (Running) Purple w/Silver White
OEM (Turn) Red w/SilverRed
OEM (Ground) White w/BlackGreen

Passenger Side Turn Indicator at Headlight
OEM (Running) Purple w/Silver White
OEM (Turn) Pink w/Silver Red
OEM (Ground) White w/Silver Green

Fog Lamp
OEM (Power) White w/Black Black
OEM (Ground) Blue Red

A. Tap into Factory Harness on each side of the truck to supply the Fog Lights. Cut wiring short if possible.

B. Route the supplied turn indicator harness under and behind the headlight.

