

American Made = American Jobs



**IRON CROSS**  
AUTOMOTIVE INC.

20/22/24-415-04

20/22/24-415-09

04-08 FORD F150

09-14 FORD F150

Front Winch Bumper

## Installation Instructions

Hardware	
24	1/2" Flat Washers
12	1/2" Lock Washers
12	1/2" Hex Bolts
12	1/2" Hex Nuts
1	Driver Side Bracket
1	Passenger Side Bracket
1	Bumper
1	1/4" - 20 Flange Bolt
1	1/4" - 20 Flange Nut

## Stock Bumper Removal

- A) Disconnect the factory fog light harness and tie up out of harm's way.
- B) Open Hood.
- C) Remove bolt holding hood release mechanism using a 10mm wrench.  
**Fig 1.**



Fig 1



IRON CROSS AUTOMOTIVE

# Stock Bumper Removal

D) Remove bolt connecting rubber splash guard from headlight. **Fig 2.**



E) Remove (3) bolts from headlight. **Fig 3.**

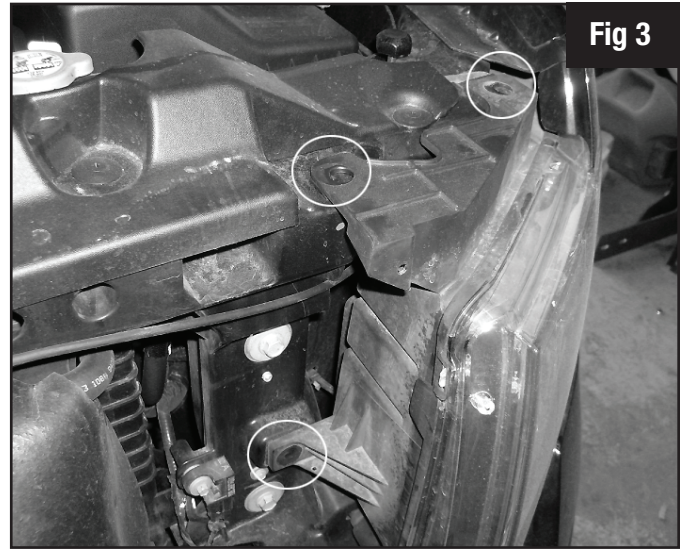

F) Remove headlight. Be careful not to break plastic plugs that fit into the quarter panel. Unplug connecting light harness. **Fig 4.**

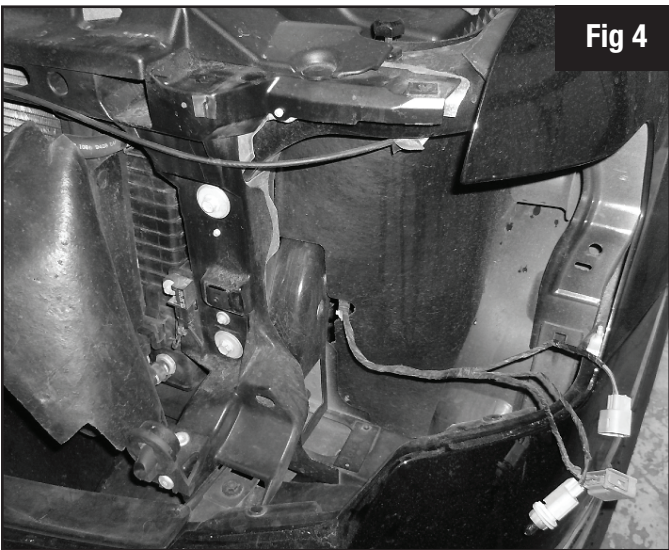

G) Remove (1) bolt from the bottom side and (3) bolts from the inside quarter panel. Use a small diameter extension to fit socket into narrow space. **Fig 5a & Fig 5b.**

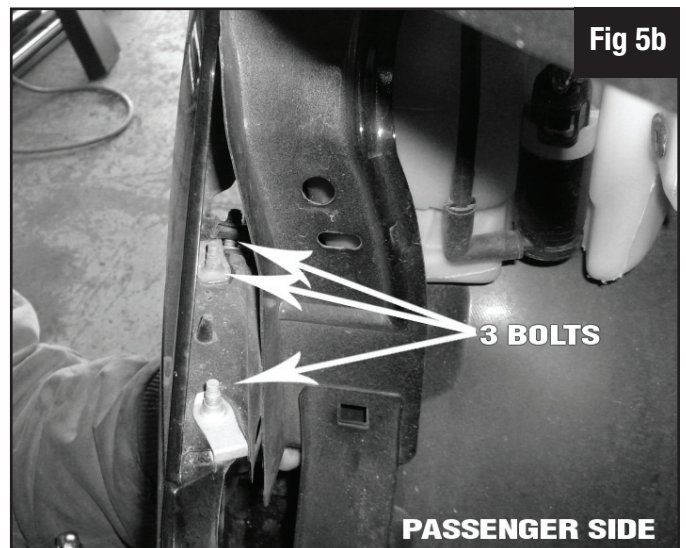
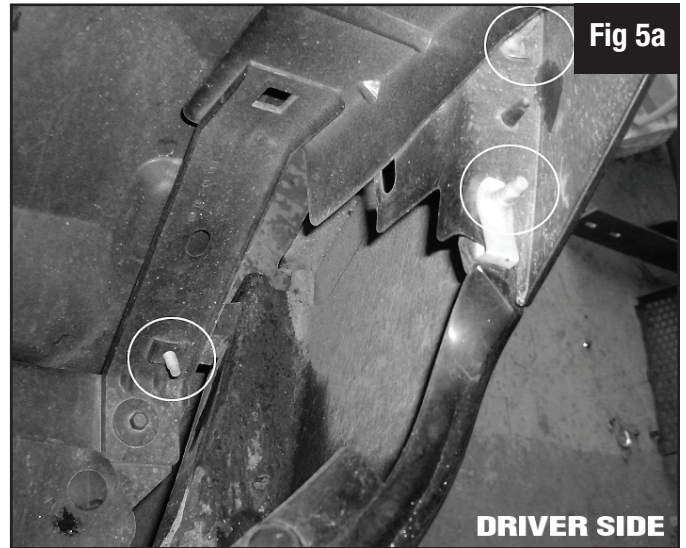

IRON CROSS AUTOMOTIVE

## Stock Bumper Removal Continued...

H) Remove bolts from each side connecting plastic bumper bracket. **NOTE:** there is a lip on the end of plastic bracket that you cannot see. Be careful once removing bumper that you do not break this plastic bracket. Tap will have to be pulled from bottom side to allow plastic bracket to release. **Fig 6.**

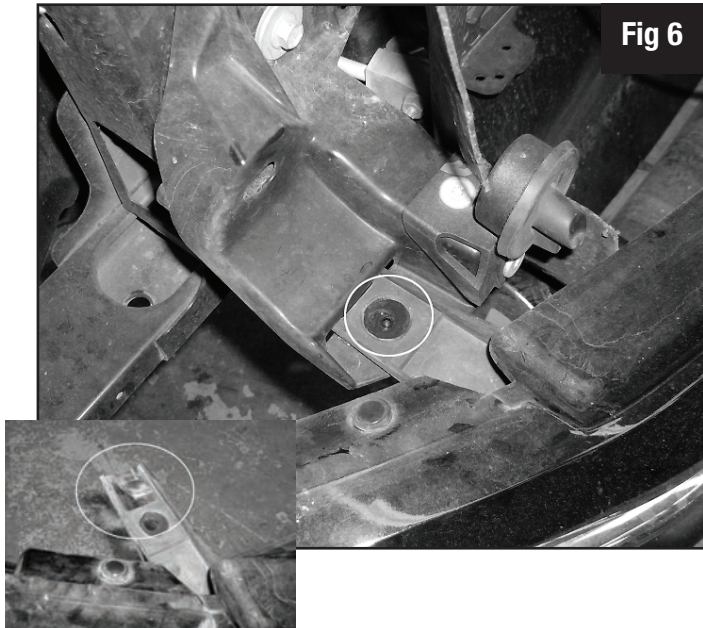

I) Remove (2) bolts from each side of frame holding bumper to frame. Be sure to place jacks or have a person hold bumper once these bolts have been removed. **Fig 7.**

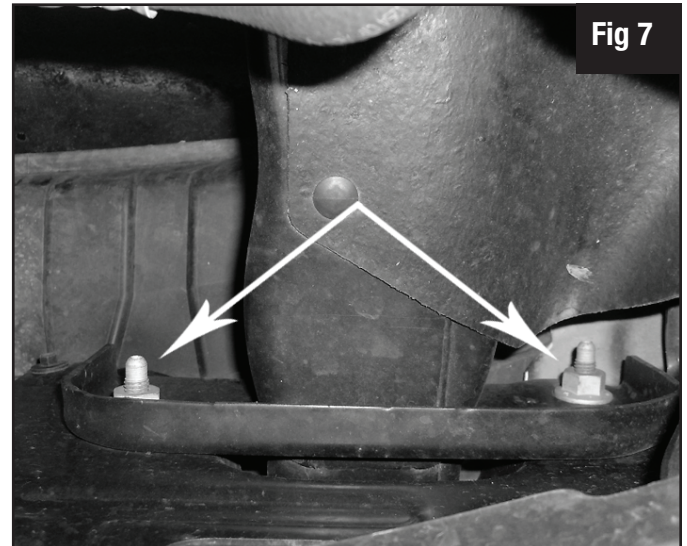

J) Remove bumper and place to side. Now your F-150 is ready for new bumper installation. **Fig 8.**

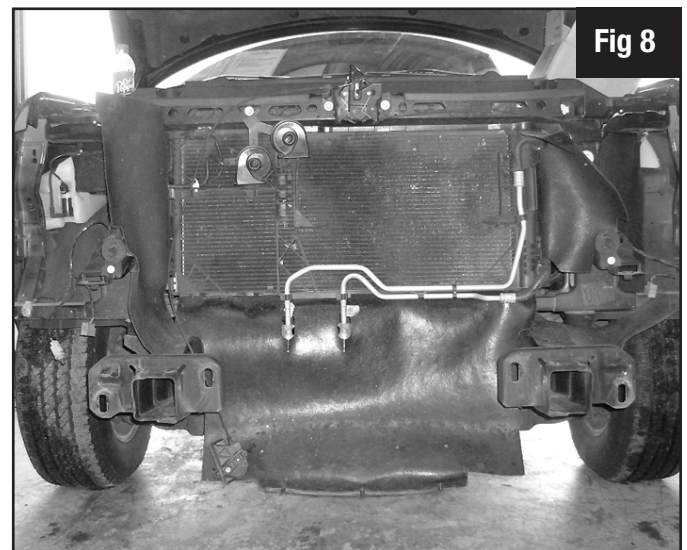

IRON CROSS AUTOMOTIVE

# Bracket Installation

**A)** Place bracket to frame mount. Use 1/2" hardware and fix bottom bracket holes to bottom side of frame. Loosely tighten to allow for final adjustment. Fig 9.

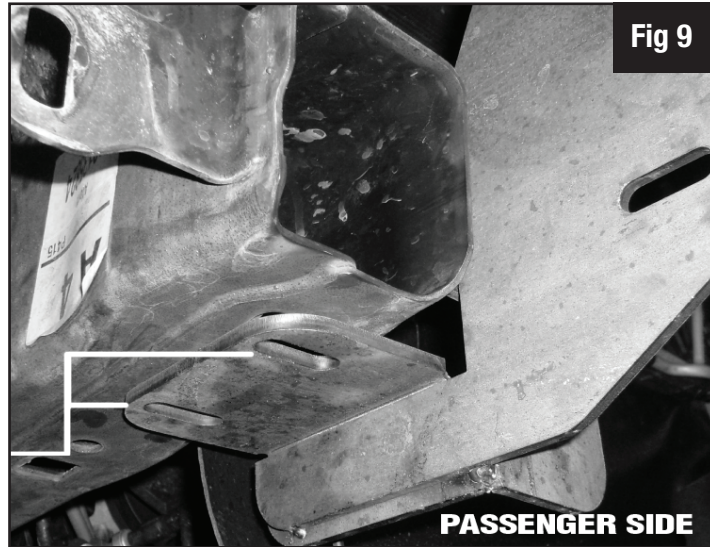

- 1/2" Hex Bolt
- 1/2" Flat Washers (x2)
- 1/2" Lock Washer
- 1/2" Hex Nut

**B)** Use 1/2" hardware and x top bracket holes to top of frame bumper mount. Loosely tighten to allow for adjustment. Fig 10.

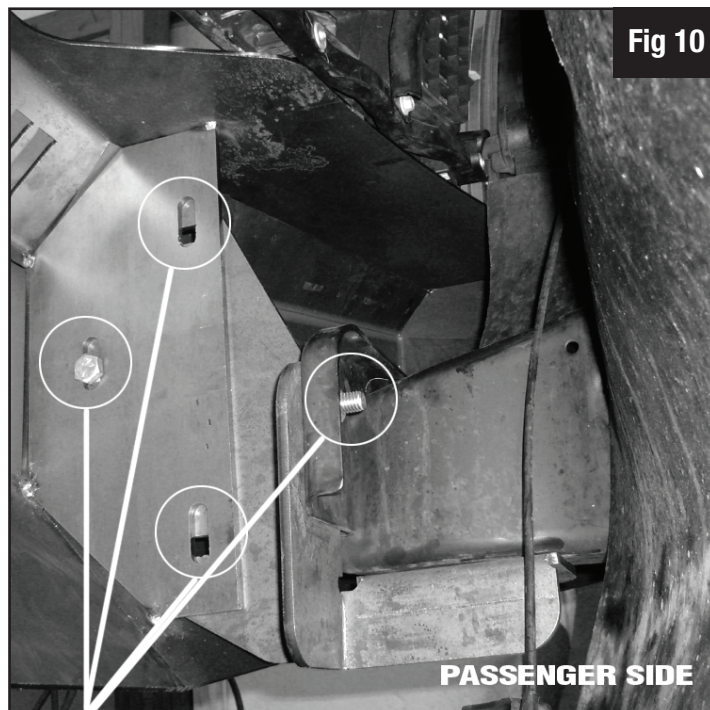

- 1/2" Hex Bolt
- 1/2" Flat Washers (x2)
- 1/2" Lock Washer
- 1/2" Hex Nut



**IRON CROSS AUTOMOTIVE**

# Bumper Installation

**A)** Carefully align bumper mount towers with intermediate mounts and slide bumper into place. Install the supplied 1/2" mounting bolts, but **DO NOT TIGHTEN FULLY**. It may be helpful to support bumper with a floor jack stand during install. Repeat for other side.

*This will at a minimum require two people to hold the bumper and a third person to install the supplied hardware.*

**B)** Adjust the bumper to achieve good visual alignment as follows:

1) Adjust "Caster" with mounting bracket bolts.

2) Adjust In/Out, Up/Down, and Left/Right with the intermediate mount bolts.

**C)** Allow 0.5" gap from all painted surfaces for frame flex.

**D)** Tighten all fasteners, beginning with frame mounts. Next, tighten all mounts to bumper fasteners.

**E)** Use 1/2" hardware and fix hood release latch to bumper. **Fig 11.**



**IRON CROSS AUTOMOTIVE**