

**Made in America**

**Lifetime Guarantee**



**Thank you for purchasing this instrument from Intellitronix. We value our customers!**

**INSTALLATION GUIDE**  
**LED Digital Gear Shift Indicator**  
**Part Number: GI001**

**\* Always disconnect the battery *before* attempting any electrical work on your vehicle.\***



## **KIT COMPONENTS**

3 – 10x32 x 3/4 Phillips head screws

2 – 10x32 Nylock nuts

1 – 10x32 x 3/8 screw

4 – nylon washers

1 – 3/8" long nylon spacer

1 – 3/8 lock washer

5 – Shift linkage parts

1 – Gear selector sender

1 – Connector – for shift sender

## **WIRING INSTRUCTIONS**

***Note: Automotive circuit connectors are the preferred method of connecting wires. However, you may solder if you prefer.***

**Ground – Black--This is the main ground for the display system. A wire should be run from this board to the vehicle engine block for the best ground.** Use 18 AWG or larger wire to ensure sufficient grounding. Proper vehicle grounding is extremely important for any gauges (or electronics) to operate correctly. The engine block should have heavy ground cables to the battery, frame, and firewall. Failure to properly ground the engine block, senders, or digital dash can cause incorrect or erratic operation.

**Power - Red** Connect to a switched +12V source such as the ignition switch.

**Dimmer - Purple** Connect to the parking lights to dim the LEDs 50% when the headlights are on. However, **do not** connect to the headlight rheostat control wire; the dimming feature will not work properly.

**Brake – Tan--**Connect to the parking brake wire from the dash to negative side of parking brake light switch. **NOTE--**If you are using a one wire switch you may need to switch to a two wire switch. This wire is an optional wire some vehicles may not require

**Check - Engine - Green/Yellow** - This will require checking the wiring diagram pertaining to the computer (ECM, PCM, ECU) that you are using. To activate the CEL, the green/yellow wire to the gauge gets grounded by the computer. In other words, this is a ground activated circuit. If your vehicle is not computer equipped then you may simply seal the end of the wire, and do not use

**Turn - Signals – Grey--**Two 18-gauge wires, one for each signal. Connect each wire to its corresponding indicator circuit. When looking from front of cluster RIGHT Grey wire is for right turn and LEFT Grey wire is for

**Brown - High Beam Indicator** – Power wire off high beam circuit to activate the Indicator when High beam is on.

### **Wiring Transmission Gear Position Sensor:**

After the sending unit has been installed and the black and violet wire have been fed through the firewall, attach the purple and black wire to the connector housing and add the lock

1 Insert the terminals into the connector housing. Match the violet and the black on the connector to the other connector to make the sender works correct.

2--Place lock on back to hold wires in place.

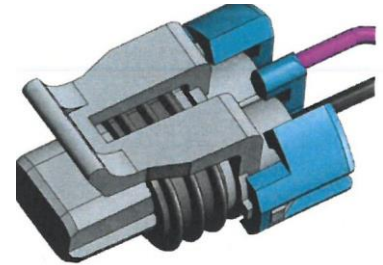
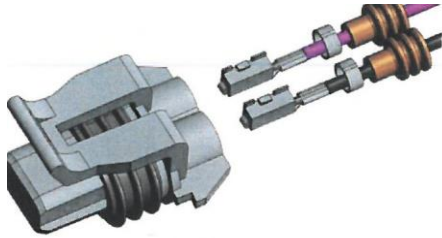

*MACHT COLORS ON CONNECTOR NOT DRAWING*

## **Gear Indicator Programming**

**Programming – Blue** - When the gear indicator has not been programmed for a specific car, you will see a question mark when you turn it on. To set it for the first time, or to reprogram it, perform the following steps:

1. Power off the gear indicator, then hold the blue programming wire to a good car ground, or to the bare ground wire from the gear indicator.
2. Power on the gear indicator while holding the programming wire to ground.
3. After you see a question mark, release the blue programming wire from ground.
4. Then ground the programming wire again. You will see gear letters appear one at a time.
5. When you see the gear letter that represents the gear your car is in right now, release the programming wire from ground. After a few seconds, you will see that letter blink, indicating that letter is saved for this gear position. (The first letter is “P”. Holding the wire at ground will go through all the letters/numbers and start over again at “P”.) If you make a mistake, you can redo a gear by holding the wire to ground until the correct letter appears, releasing the wire from ground, and waiting for it to blink.
6. Shift your car into the next gear.
7. Hold the programming wire on ground until you see the letter/number for this next gear.
8. Release the wire from ground and wait until the letter blinks.
9. Continue for all the gears.

Make sure the blue programming wire does not touch ground again (electrical tape, etc.). Power down the gear indicator and power it back on. Shift through all the gears and check the gear indicator functions as desired. You can always reprogram it starting with step one

## GEAR SHIFT LINKAGE ASSAMBLEY

We have provided you with linkage parts to install the sensor that provides signal to gauge. Pick location on Transmission pan rail to mount sensor bracket. Remove bolt out of pan to check length through sensor bracket and provided nylon spacer. If you don't have 3/8 of thread past spacer THEN REPLACE BOLT so it can be properly torque down to Transmission pan specifications.

The linkage should line up and not have a bind on it. After hooking linkage up run through the gears to check fitment for a bind before final hook up and programing You can softly modify linkage to fit and trim off any length that may be interfere with movement. REMEMBER MEASURE TWICE CUT ONCE!!

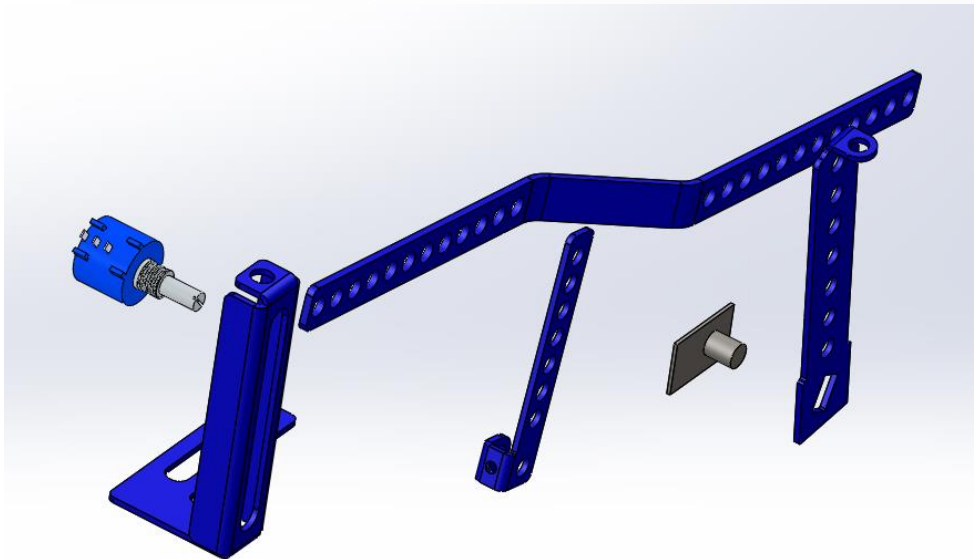
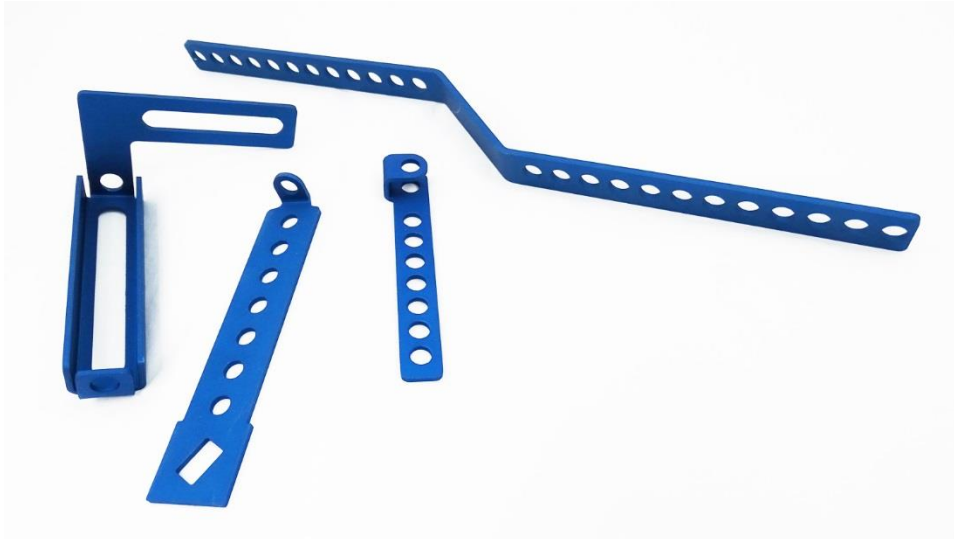

The examples below are for guiding you on your installation of your new Gear Shift Indicator.

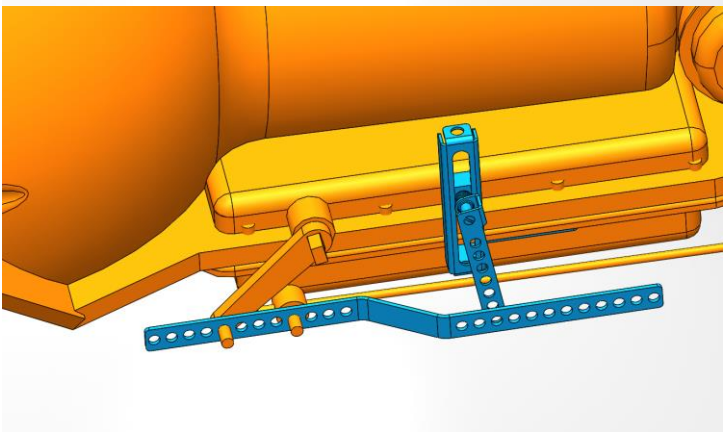
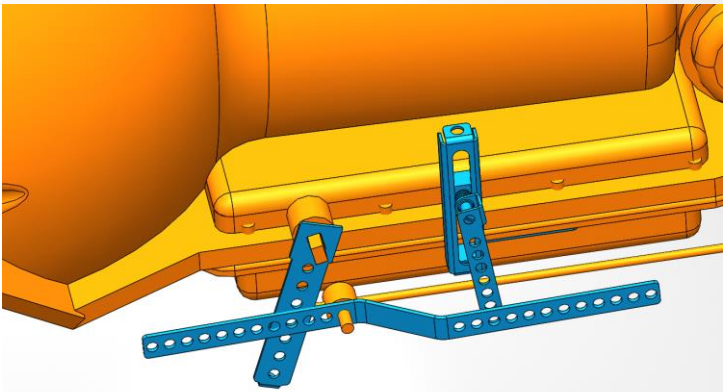
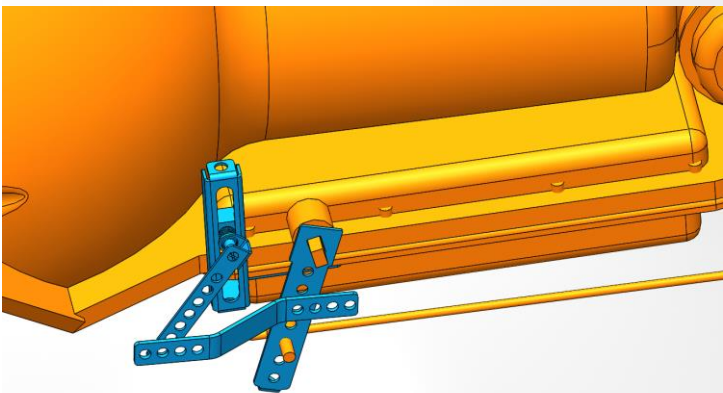
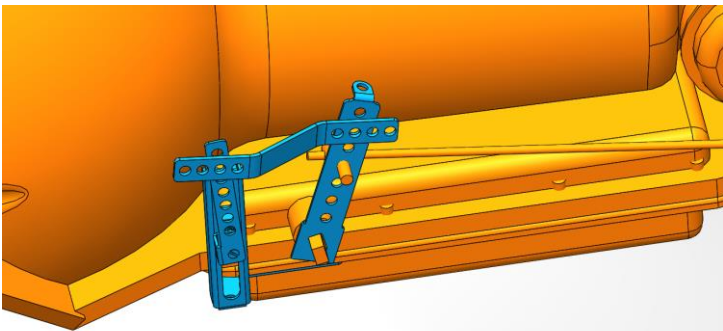

Check out the collection of custom gauges we offer.