



XA568/XA569 Installation Instructions

Before using this product, carefully read this instruction manual for proper use. Keep this instruction manual in a safe place.

If you are to give this product to a third person, provide him/her with this manual as well to ensure safe use.

The following symbols are used throughout this manual for your attention

Matters and precautions that require special attention are explained using symbols in this manual. Each symbol and its description are as follows.

 Warning	Failure to follow this warning can result in serious accidents including death or serious injury.
 Precautions	Failure to follow precautions can result in injury, damage to the product, vehicle, or load.
 Note	Things that you should know are described in this section.

Be sure to follow the instructions

Please be sure to follow the matters listed hereafter for safe usage of this product.

Warning

Warning when installing or using this product

Be sure to inspect that all screws, bolts, and nuts are securely tightened before driving the vehicle. If loose, tighten more. Loose screws, bolts, or nuts may result in rack or load to fall off due to wind pressure or vibrations involving the car behind or a person in an accident. Also, periodically inspect them and retighten any loose screws, bolts, or nuts.

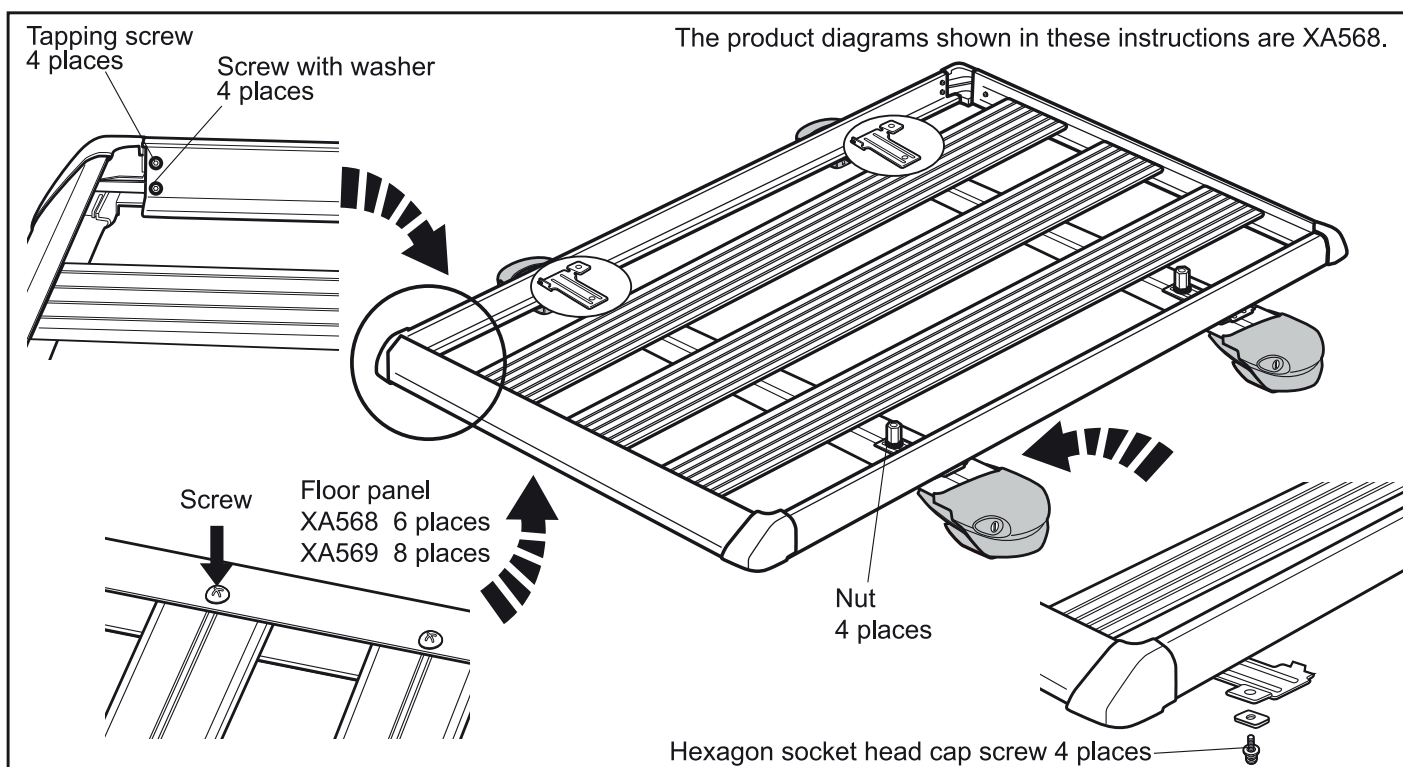

⚠ Warning

Warning when installing the product

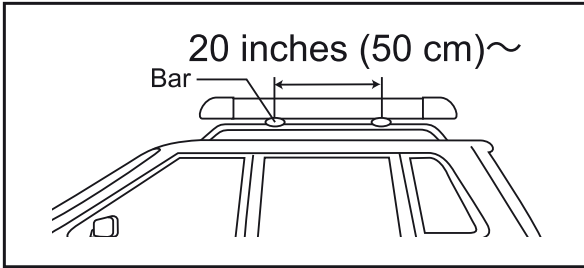

Secure 20 inches (50 cm) or more space between the front and rear bars.

When the cargo basket is installed with a short bar spread (less than 20 inches), excessive force is applied to the cargo basket causing the cargo basket or the load to fall off involving the car behind or a person in an accident.

When the bar spread is specified by vehicle model, install the bars in accordance to the specified dimensions.

Warning when using the product

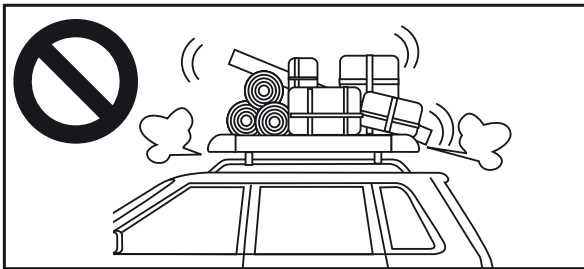

Do not exceed the maximum load capacity when loading. The maximum load capacity differs depending on the combination of the cargo basket and the vehicle model. Refer to the Fit Guide. Refer below for the method on calculating maximum load capacity.

When the load exceeds the maximum load capacity, excessive force is applied to the cargo basket which may cause the cargo basket or the load to fall off involving the car behind or a person in an accident.

How to calculate maximum load capacity

(When this cargo basket is the only product mounted on the carrier.)

Cargo basket's allowable load capacity XA568 / XA569
Within 110 lbs (50 kg)

=

Maximum load capacity per vehicle model

—

Weight of cargo basket
XA568 14 lbs (6.7 kg)
XA569 17.4 lbs (7.9 kg)

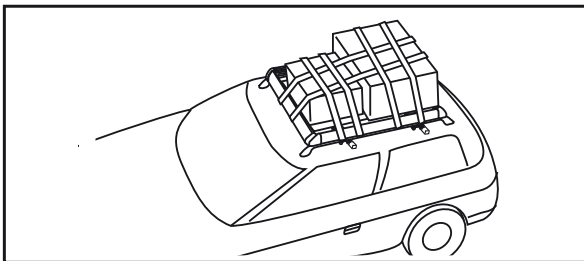

Be sure to securely fix the load with a belt, net, and/or rope. Travelling at high speeds or carrying a load weighing 22 lbs (10 kg) or more results in excessive force being applied to the load due to wind pressure and when starting or stopping the car. Always use a belt.

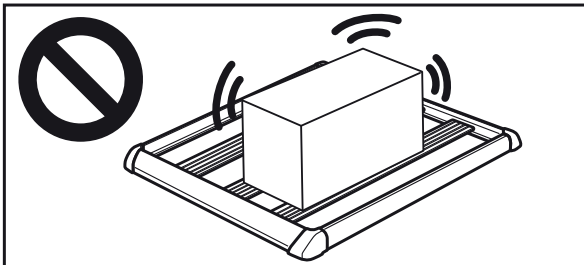

If the load is not securely fixed, the load may fall off involving the car behind or a person in an accident.

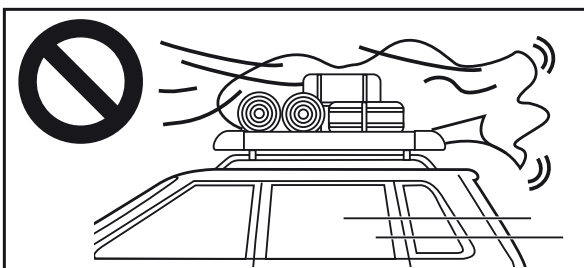

In order to prevent the water proof sheet or similar sheet from flapping, securely fix the sheet, with a belt, net, and/or rope before travelling.

Travelling with these sheets flapping may cause the load, the cargo basket, or the carrier to fall off by wind pressure involving the car behind or a person in an accident.

Warning

Warning when using the product

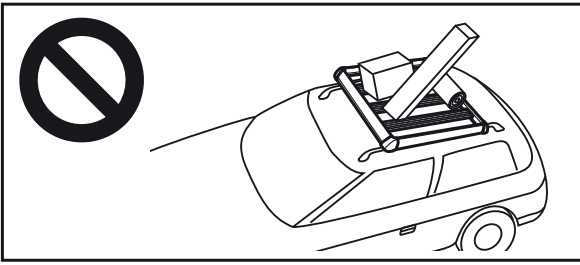

Load the cargo so that it is evenly distributed and level. Do not stack the cargo high or have it leaning to one side or slanting.

If the cargo weight is not evenly distributed or the cargo is not level, it may fall off by wind pressure during travel involving the car behind or a person in an accident.

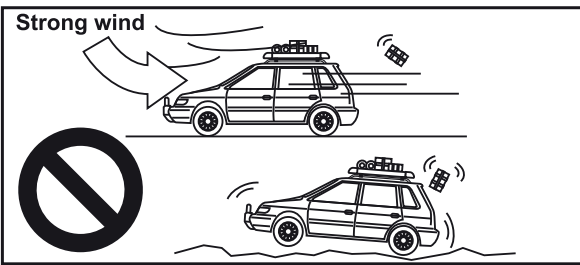

Obey all posted speed limits. Drive slower under strong winds or on rough roads.

Driving continuously at a speed exceeding the legally permitted speed or in the strong wind as well as driving on rough terrain may cause the cargo basket, carrier or load to fall off due to loose nuts, screws, or bolts involving the car behind or a person in an accident.

Precautions

Precautions when using the product

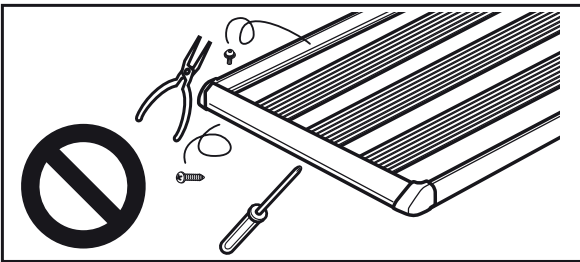

Do not alter this product.

A modified product may not securely attach to the vehicle and cause the cargo basket or load to fall off involving the car behind or a person in an accident.

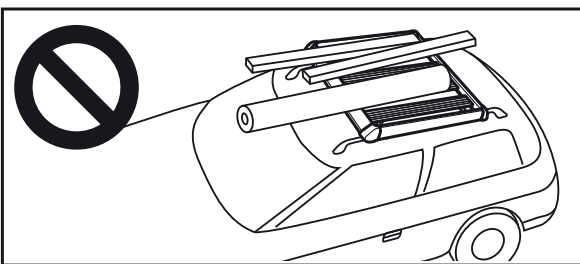

Do not load the cargo so that it protrudes from the cargo basket.

Loading the cargo protruding from the cargo basket may apply excess force to the front/rear and/or side panel causing deformation or damage.

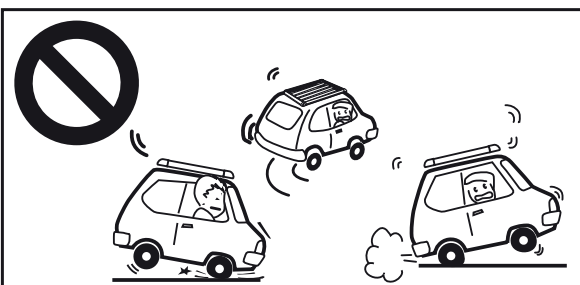

Avoid sudden starts, stops and sharp turns as the cargo basket and the cargo raises the center of gravity of the vehicle high.

Be sure to check that the carrier and load are secure after driving under adverse traveling conditions.

Making sudden starts or stops, or sharp turns when the cargo is loaded may shift the carrier or the attachment from the installed position causing damage to the vehicle, product, or cargo.

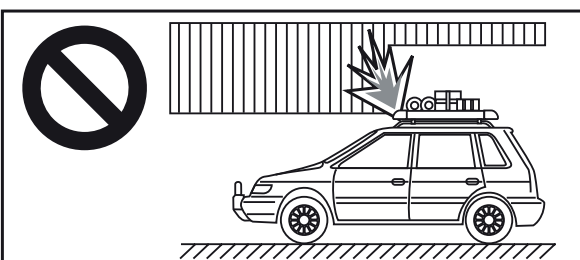

Installing the cargo basket to the vehicle increases the vehicle height, so pay full attention to obstacles above the vehicle when driving.

Should the cargo basket or the cargo be impacted, be sure to check the cargo basket, carrier, and cargo.

Check the product contents



No.	Parts	Q'ty	
		XA568	XA569
①	Front/Rear panels (same)	2	2
②	Side panels (same)	2	2
③	Floor panels	3	4
④	Installation parts	4	4
⑤	Square head bolts	4	4
⑥	Spacers	4	4
⑦	Nuts	4	4
⑧	Spring Washers	4	4
⑨	Rubber caps	4	4
⑩	Nut plates	4	4
⑪	Hexagon socket head cap screws	4	4
⑫	Tapping screws (Large) (For fixing floor panels)	6	8
⑬	Tapping screws (Small)	4	4
⑭	Screws with washers	4	4
⑮	Rubber sheets	6	8
⑯	Wrench (10 mm)	1	1
⑰	Hex Wrench (B=4)	1	1
⑱	Installation instructions	1	1

Prepare Necessary Tools

A Phillips screwdriver is required for assembling this product.

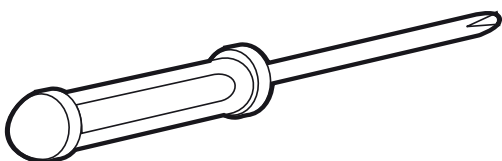

Note

Prepare a Phillips screwdriver which fits the plus-shaped groove.

Confirmation Before Use

This product can be attached not only to the INNO aero bar but also to the factory crossbar whose T-slot fits the dimensions below.

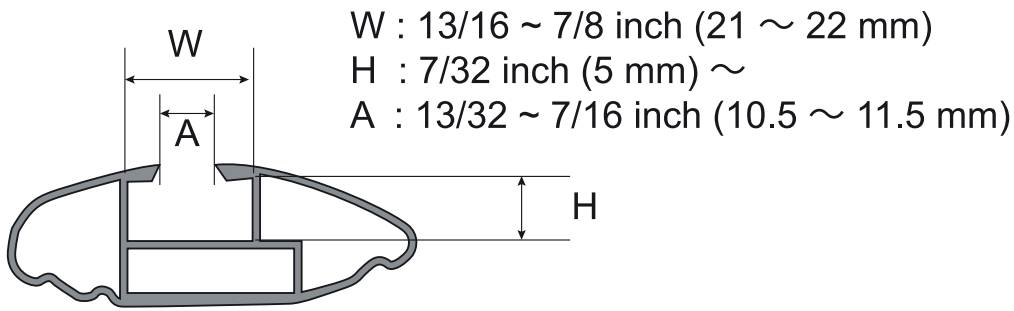

Installing Procedure

Installing T-slot base systems

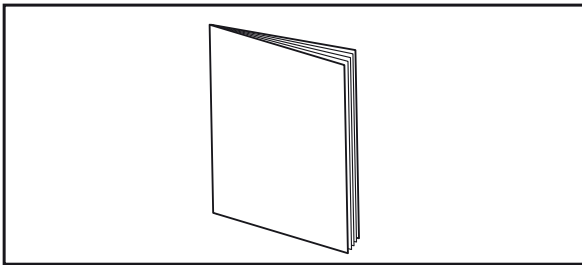

Correctly install the base carrier in accordance with the installation instructions.

Precautions

Confirm the stability and strength of the base carrier onto which this product is to be installed, and attach it securely.

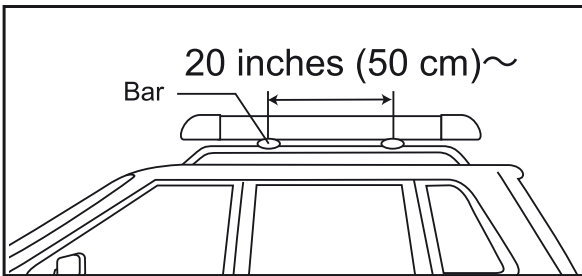

Secure 20 inches (50 cm) or more space between the front and rear bars.

When the bar spread is specified by vehicle model, install the bars in accordance to the specified dimensions.

Assemble the cargo basket

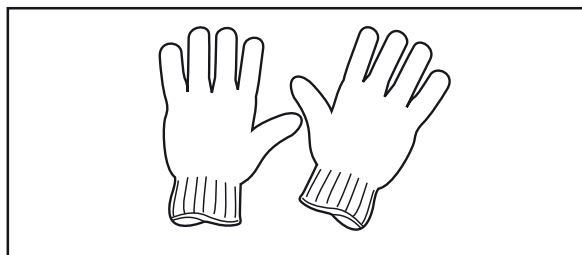

Precautions

Always wear gloves when assembling the cargo basket. The aluminum edges may injure your hand or fingers.

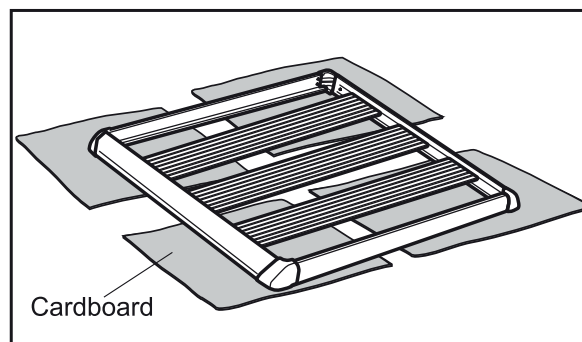

Note

Conduct assembly work on a sheet of cardboard laid out on a flat surface. Assembling directly on the ground damages the product.

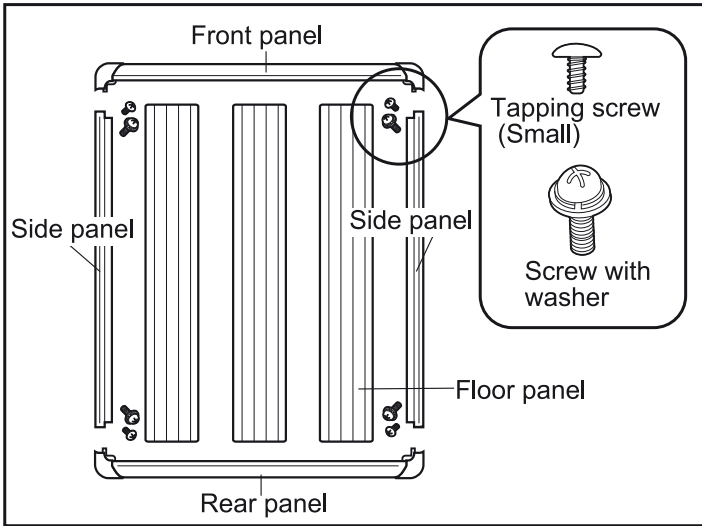

1 First, check the quantity of the product body and parts, then place the front and rear panels, the floor panels, the side panels, and screws as shown in the figure.

(XA568 Floor panels 3 places
XA569 Floor panels 4 places)

Note

Place the floor panels with the non-slip face up and the face with the concave center down.

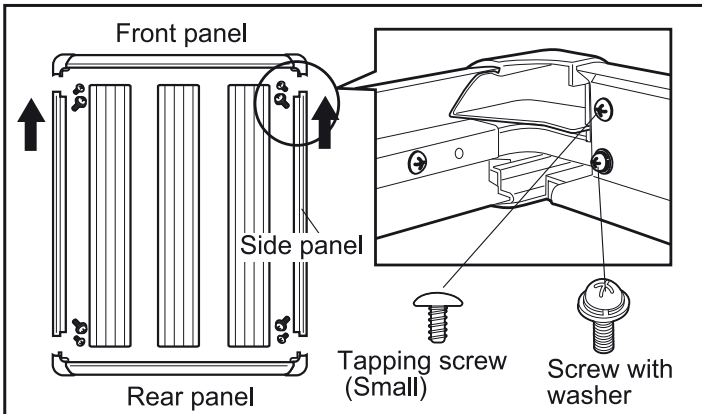

2 Assemble the front panel and the side panels. Insert the side panels into the front panel and fix the upper side with tapping screws (small) and the lower side with screws with washers.

(At this point, fix the side panels to the front panel just in 2 places (left and right).)

Precautions

When fixing the side panels to the front panel, over tightening the tapping screws (small) at upper side damages the screws, and the screws will not be able to be tightened further. Do not over tighten the screws.

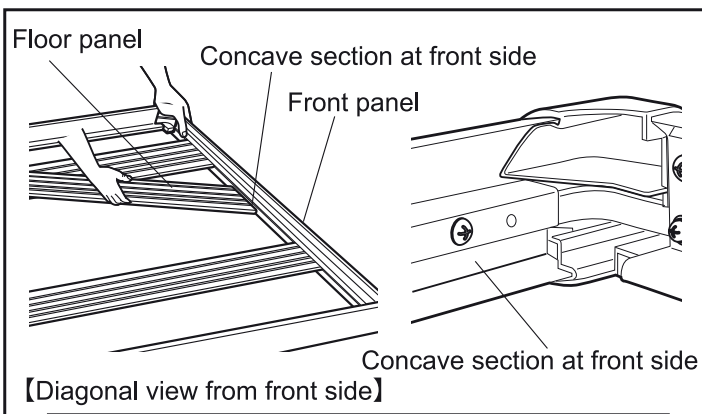
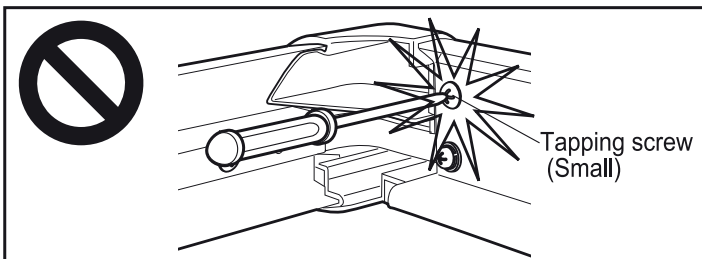

3 Temporarily place the floor panels. Place the floor panels over the concave section located inside the front panel.

(XA568 3 places
XA569 4 places)

Note

Place the floor panels with the non-slip face up and the face with the concave center down.

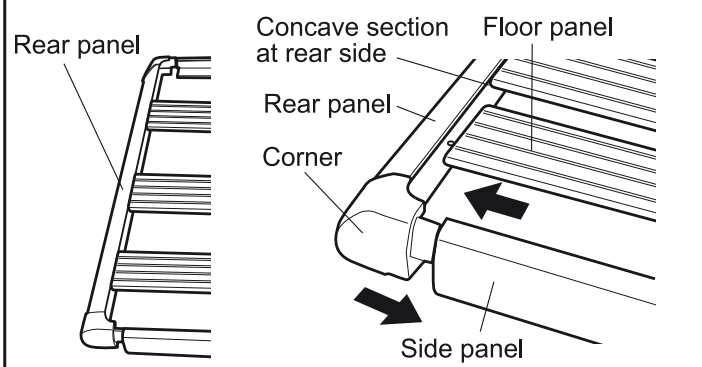

Place the floor panels over the concave section located inside the rear panel, and insert the rear panel into the side panels while holding the corner of the rear panel so as to prevent the floor panel from being dropped.

(Insert the rear panel to the side panels on left and right sides (2 places).)

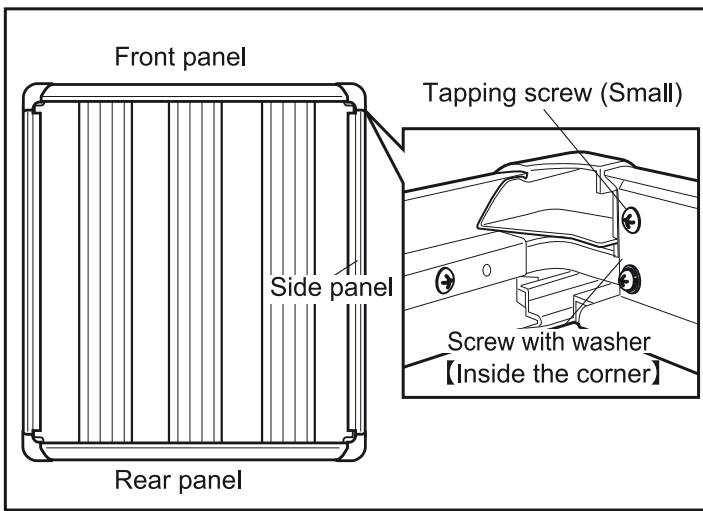

Fix the rear panel and the side panels in the same manner as done for the front panel using the tapping screws (small) for upper side and screws with washers for lower side.

(Conduct this procedure at left and right sides of the rear panel (2 places).)

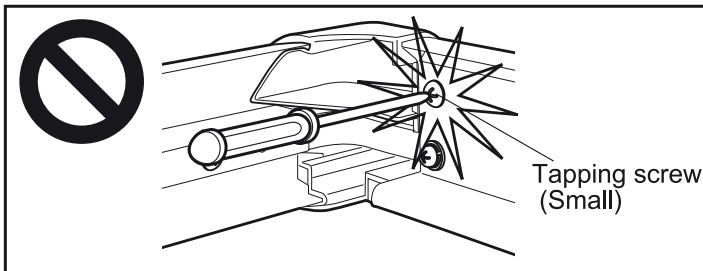

⚠ Precautions

When fixing the side panels to the rear panel, over tightening the tapping screws (small) at upper side damages the screws, and the screws will not be able to be tightened further. Do not over tighten the screws. (Common for the front and the rear. There are 4 places in total, 2 places on both left and right sides.)

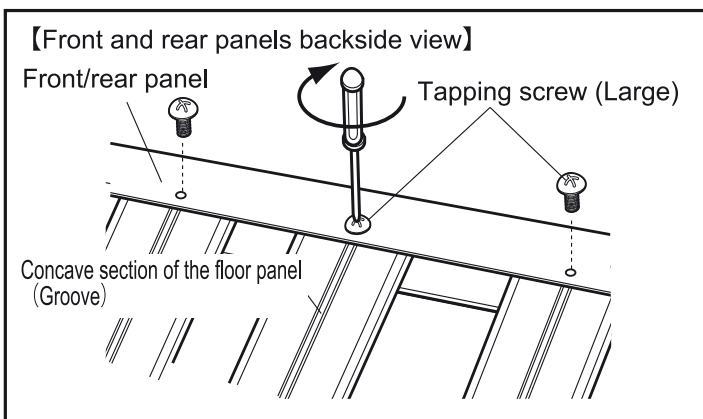

4 Turn the body over, align the concave section (groove) of the floor panel with the screw holes of the front and rear panels, and fix them with tapping screws (large) .

(XA568 Front/rear panels 6 places
XA569 Front/rear panels 8 places)

⚠ Precautions

Tighten tapping screws (large) straight.

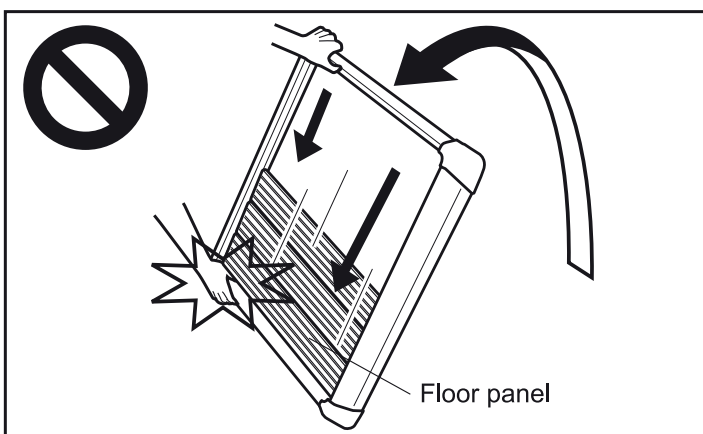

⚠ Precautions

Do not turn the body over in the direction shown in the figure on the left, or your hand may be caught. Turn the body over in the longitudinal direction of the floor panel.

Mount the cargo basket to the aero base

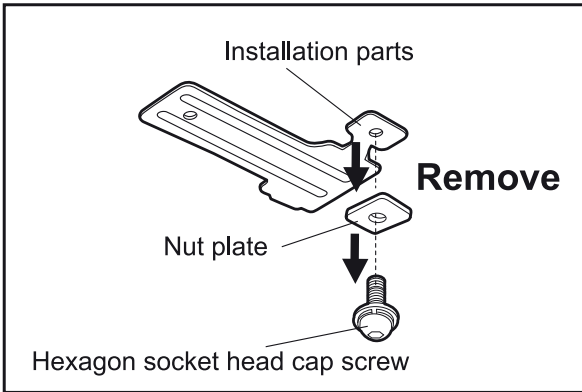

Conduct all work in the 4 locations, front, rear, right, and left sides.

1 Remove the hexagon socket head cap screw and the nut plate from the installation part.

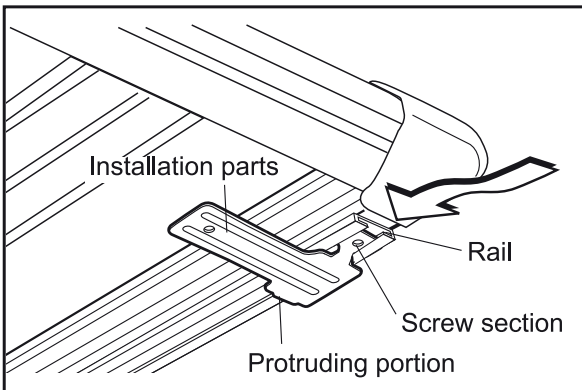

2 Insert the protruding portion and the screw section into the rail of the side panel so that the installation part faces inside the side panel.

(Conduct this work in 2 places of the side panels on right and left sides (4 places in total).)

⚠ Precautions

Insert the protruding portion of the installation part into the rail. The side of the screw section cannot be inserted.

⚠ Precautions

Insert the installation part facing inside the side panel. Inserting it facing outside the side panel causes deformation.

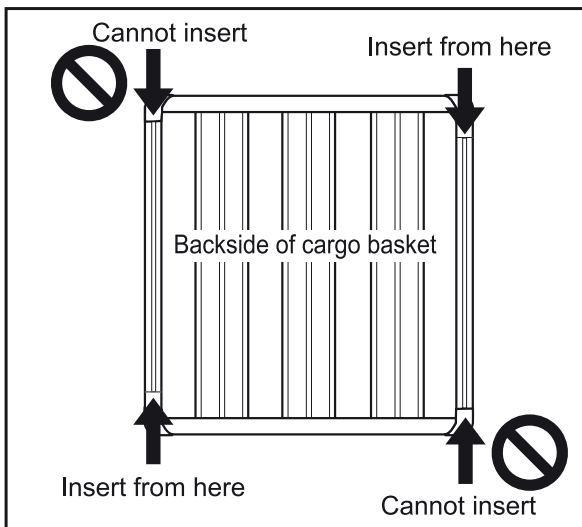

3 Decide the cargo basket position and adjust the position by sliding to the position where the installation part comes on the bar.

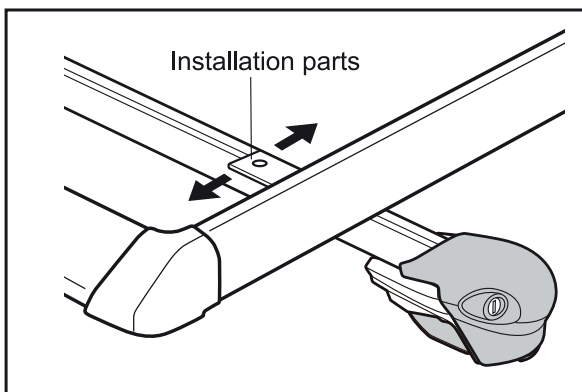

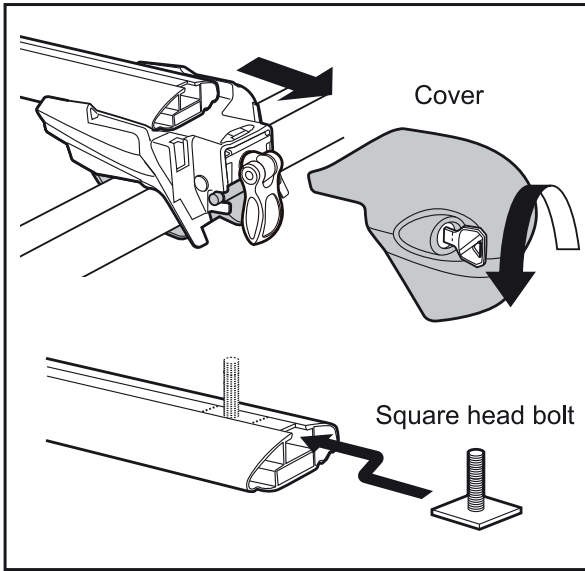

4 When the base has a cover, remove it. Set the square bolt to the T slot, install the cover, and lock it if available.

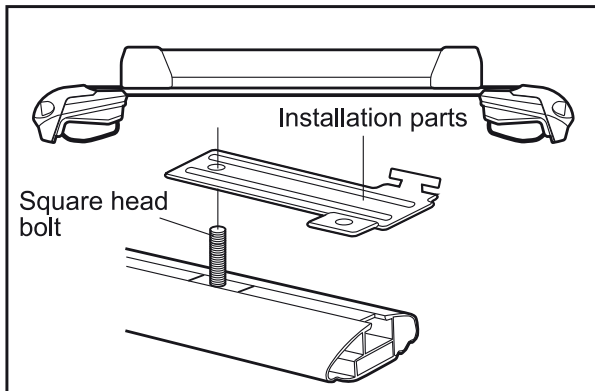

5-A When the side panel of the cargo basket cannot be placed on the base cover, lift the rack and slide the square bolt to pass through the installation part hole.

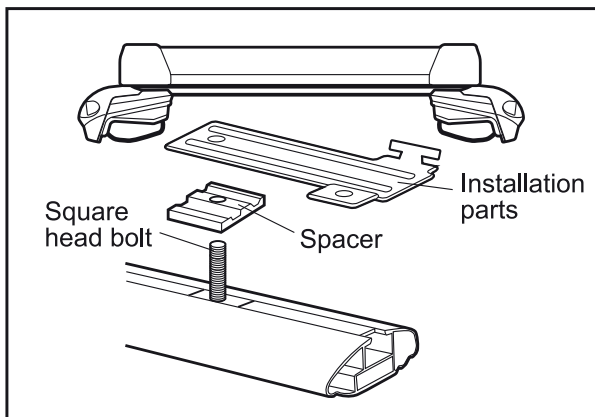

5-B When the side panel of the cargo basket can be placed on the base cover, lift the cargo basket and slide the square bolt to pass through the spacer and installation part holes with the spacer rubber part facing down. At this point, line up the convex and concave sections of the spacer and the installation part.

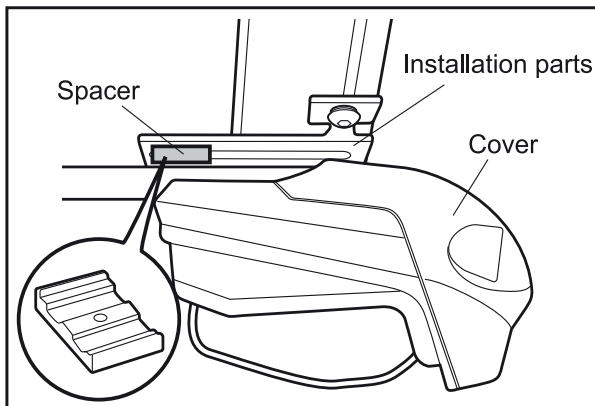

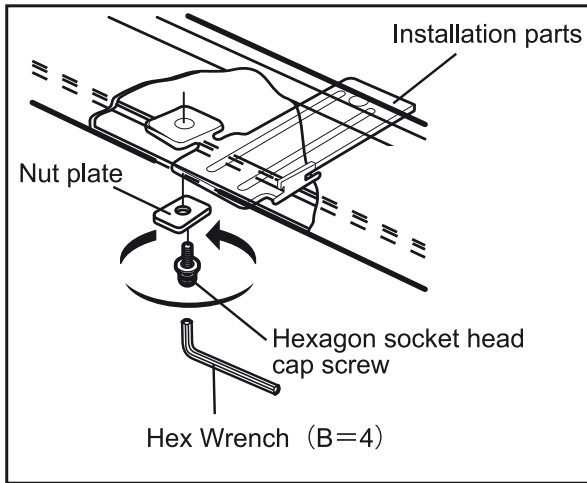

6 Using the installation part, nut plate and the hexagon socket head cap screw, tighten them. However, over tightening may result in deformation of the cargo basket.

⚠ Precautions

Insert the nut plate carefully.
The nut plate has different length and width.
If inserted wrong direction it may cause deformation of the nut plate or side panel.

⚠ Precautions

Tighten the hexagon socket head cap screw until the spring washer is flat. Tighten further to the extent that the nut plate of the cargo basket does not deform. Standard of tightening torque is 4 [N · m] (3 ft.lb).

👉 Note

When the hexagon wrench does not fit due to interference by the cover, lift the cargo basket once and tighten.

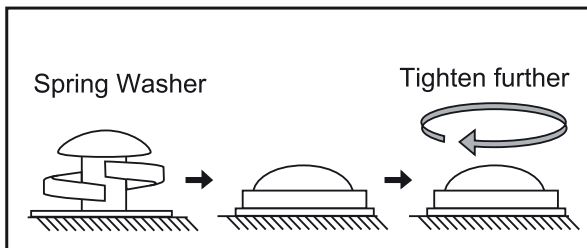

7 Apply a rubber sheet to the backside of the floor panel where the floor panel and bar interfere.

👉 Note

Without the rubber sheet, the bar may be damaged or cause rattling sounds.
When re-installing, install the aero base to the same place.

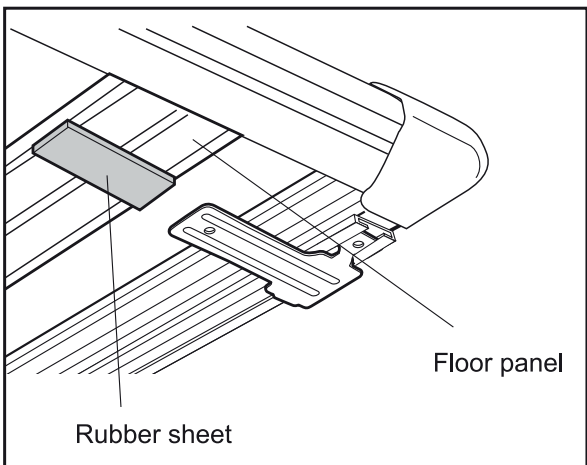

8 Pass the spring washer through the square bolt, set the nut, and tighten with the included wrench.

⚠ Precautions

Tighten the nut until the spring washer is flat.
Standard of tightening torque is 4 [N · m] (3 ft.lb).

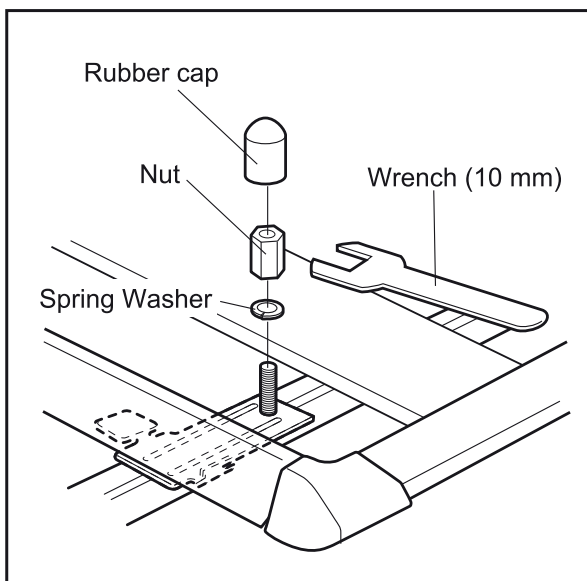

9 Insert the rubber cap to the nut as far as it goes.

How to Use

Load the cargo

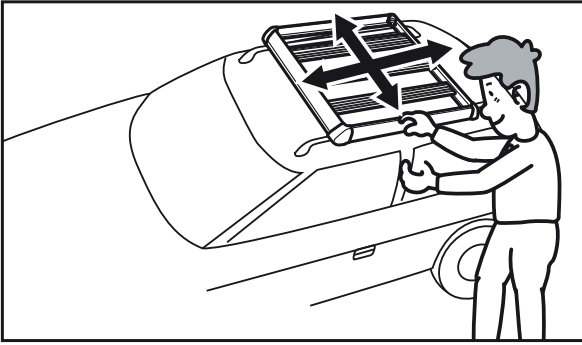

- 1 Before loading the cargo and driving the car, be sure to shake the cargo basket to the front, rear, left, right, up and down to check for rattling caused by loose nuts, screws, or bolts and confirm that the cargo basket is securely fixed to the bar.

Confirm that the cargo weight does not exceed the maximum load capacity.

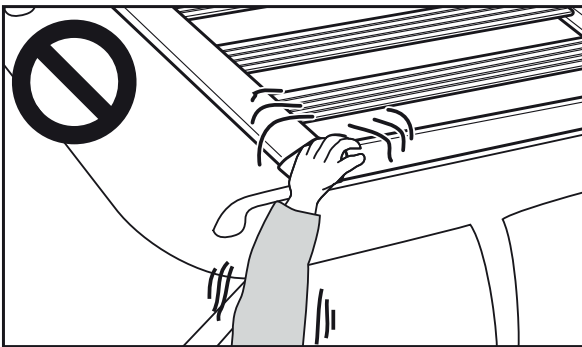

Precautions

Do not attach the net hook or apply excessive force to the corner plastic part.

Note

Scratches on the panel caused by the cargo may become noticeable.

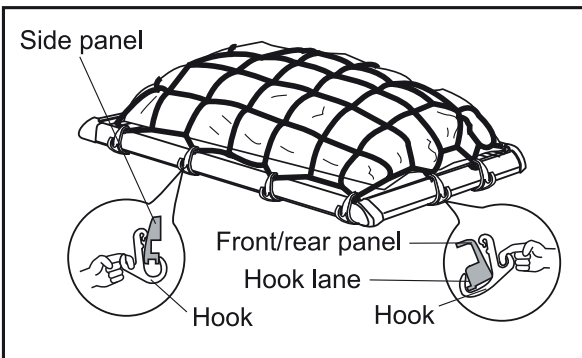

Precautions

Do not attach the net hook to the floor panel.

Note

Attach the net hook for fixing the cargo to the entire lower side of the side panel or hook it deeply between the front/rear panel and the floor panel.

Daily Maintenance

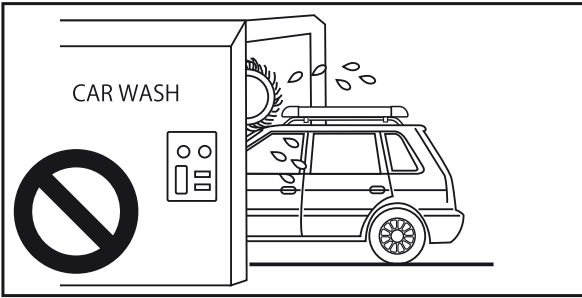

Warning

Remove the carrier before using an automatic car wash. Should the car mistakenly be washed by an automatic car wash with the carrier attached, be sure to inspect the carrier.

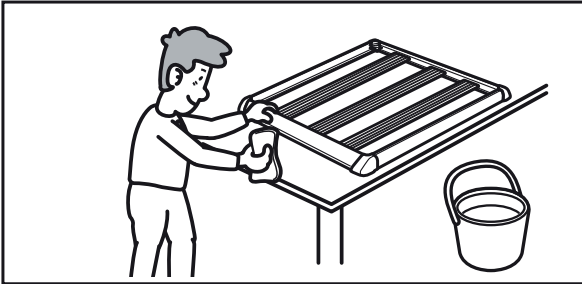

- 1 Wipe off dirt with a well-wrung towel, or a neutral detergent solution.

Note

Blue or green smudges may appear on the Cargo basket if it has not been washed for a long period of time. These smudges are not the result of material deterioration but are caused by dirt adhering to the surface.

Wipe clean using water or a neutral detergent.

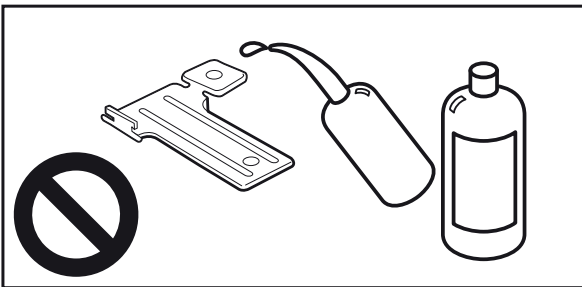

Note

Do not apply oil or thinner (including paint) to this product.

Care and storage

Inspecting the parts

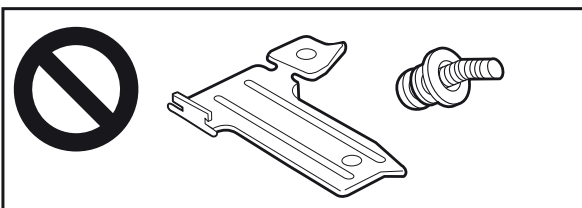

- 1 Clean the parts, and inspect each of the parts for abnormalities.

Storage

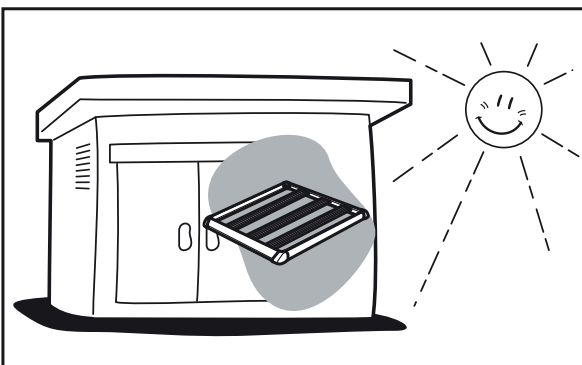

- 1 Store in a covered, dry location away from sunlight.

Precautions

When not in use, remove the cargo basket from the vehicle and store in a safe place to avoid rust or deterioration caused by rain or UV.

Put small parts such as bolts and nuts in a plastic bag and store with attachment.

Repair parts

Please specify part name when ordering repair parts.

Note

Specifications and appearance of the carrier system and genuine replacement parts are subject to change without prior notice in the interest of product improvement.

