

Installation Instructions

Before using the Mounting hooks, carefully read the installation instructions as well as the installation instructions for basic carrier systems, and follow all usage instructions. After reading the installation instructions, keep it in a safe place along with the installation instructions for basic carrier systems. If you are to give the mounting hooks to a third person, provide the installation instructions to ensure safe installation and usage.

WARNING

Install hooks correctly at specified positions according to the installation instructions herein and the installation instructions for the applicable carrier system. Installation positions of hooks depend on the vehicle type. If hooks are not installed at specified positions, the carrier may fall and cause accidents.

If inappropriate hooks are used, the carrier / attachment may fall and cause accidents. Before driving the vehicle, rock the stays and bars in all directions to ensure that there is no looseness. Retighten any loose knobs or bolts.

Do not use these hooks for attachments of non-specified types. The carrier may fall and cause accidents.

Observe the specified loading conditions. Failure to observe the loading condition may cause the carrier to break or loosen and fall, resulting in accidents.

For INNO dedicated ski & snowboard carriers, read the carrier installation instructions to determine proper mounting locations.

The TR Mounting hooks include the parts listed below. Verify that all of these parts are included in the carrier system you have purchased.

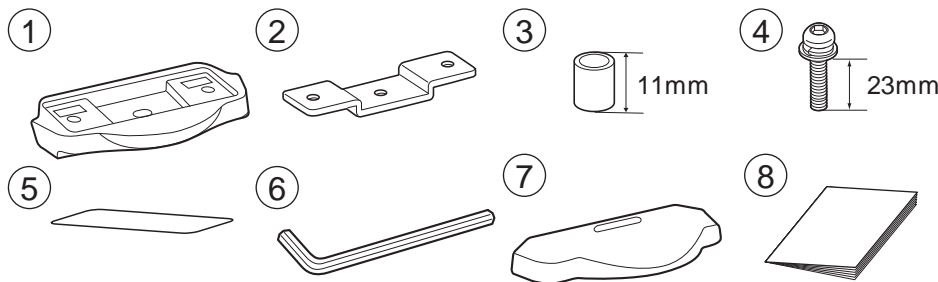

No.	Part	Qty
	Cushion base 514	4
	Base bracket	4
	Spacer [11mm]	4
	Bolt [M6x23mm]	4
	Protection sheet	8
	Hex Wrench [B=4]	1
	Base Cover	4
	Installation Instructions	1

NOTE

The specifications or external appearance of this product or any of the genuine spare parts may be changed for improvement without prior notification.

Manufacturer	Vehicle model	Vehicle type	Model year	Loading conditions	
				Maximum Load Capacity	Bike
MAZDA	CX-7		2007 - 2012	140 lbs (64 kg) (Load + Base rack + Attachments)	3
	CX-9		2007 -		

Vehicle preparations

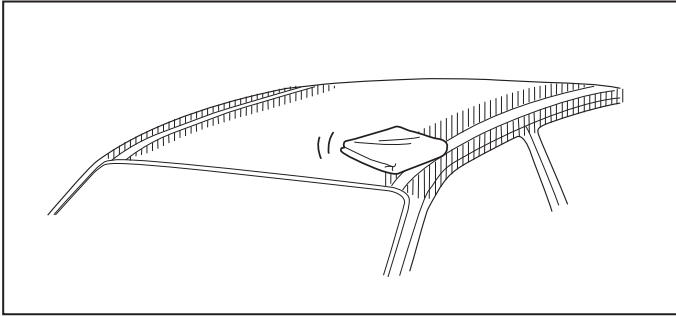

1 Cleaning the installation area on the vehicle

Wipe dirt and oil off the roof and moldings using diluted mild detergent, and then dry the wiped area.

*Shaded area in the figure.

NOTE

Do not use organic solvents such as thinner or benzene to clean dirt and oil.

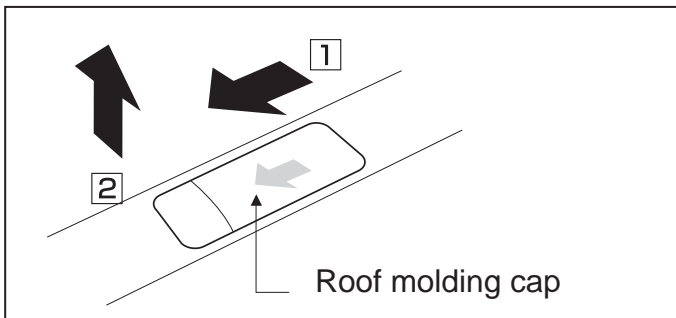

2 Removing the caps of the roof molding

Slide the roof molding cap to the direction 1, and then lift it up to the direction 2.

NOTE

Keep the removed roof molding caps in a safe place. They will be reused when the carriers are taken off.

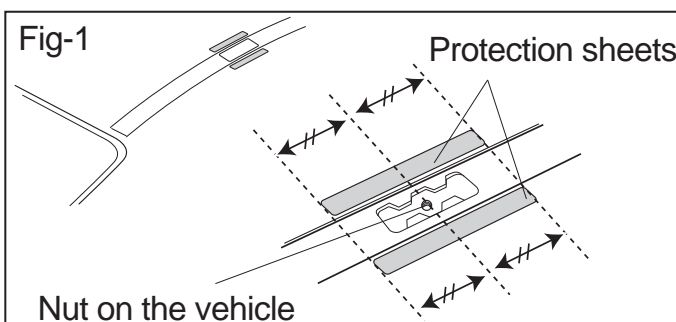

3 Applying the protection sheets

Apply the protection sheets to the area of roof molding on the roof.

Apply each protection sheet aligning its center to the nut on the vehicle as shown in the Fig-1, and also place one edge of the protection sheet along with the end of radius curve on the roof molding (see Fig-2).

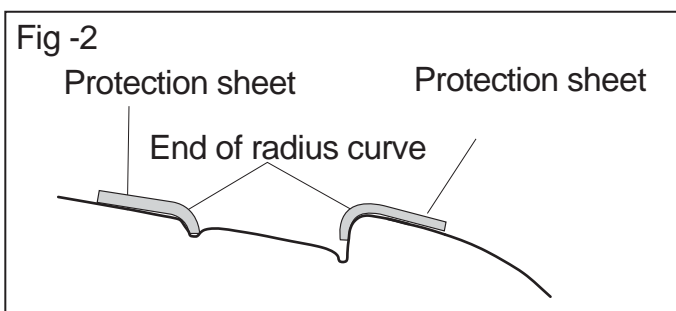

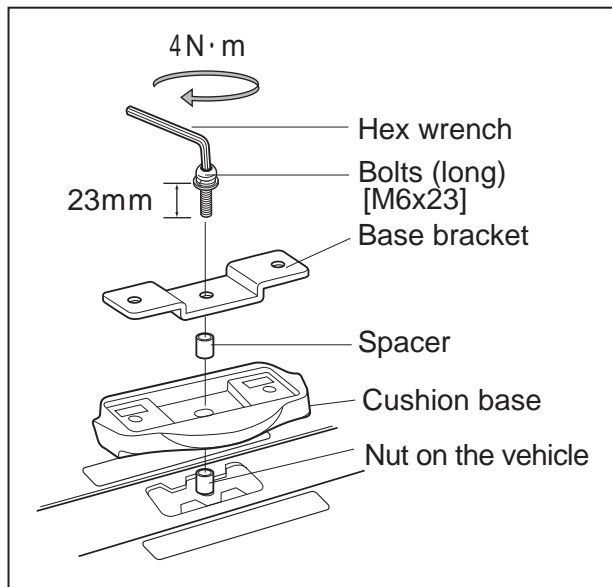

4 Attaching the base brackets

Attach them to the nut on the vehicle as shown in the figure. Secure them with the long bolt [M6x23] (included) using the Hex wrench (included) until the bolts are firmly tightened while holding both together parallel to the roof molding.

Reference

All base brackets (4 pcs.) are identical. The bracket is symmetrical with respect to the side-to-side axis; its installation orientation does not matter.

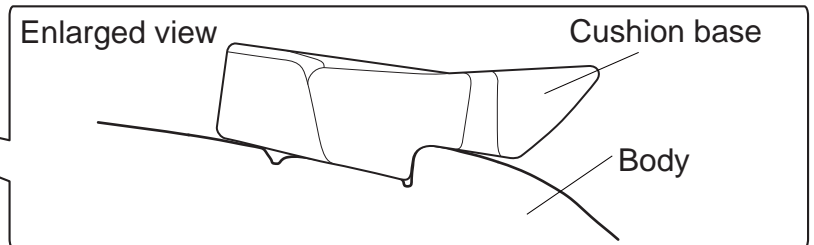
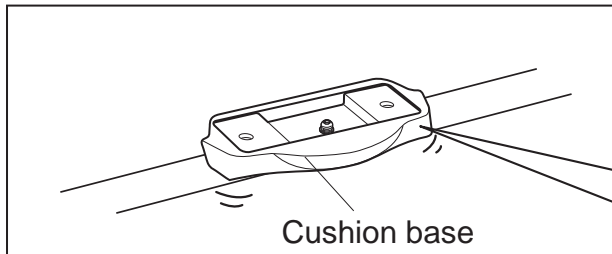

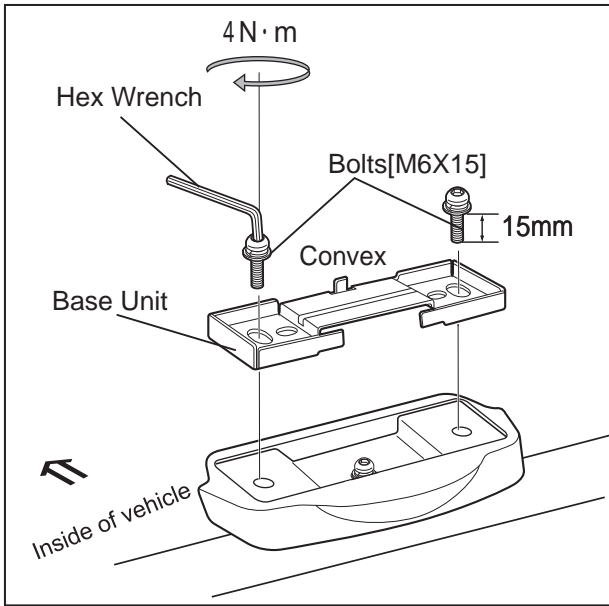

- 1 Place the base unit on the installed cushion base/base bracket. Then using the Hex wrench (included), tighten while alternating between the right and left bolts (short) [M6x15] (supplied with the carrier) until the bolts are firmly tightened. Place the base unit in a way that the convex section is on the inner side of the vehicle.

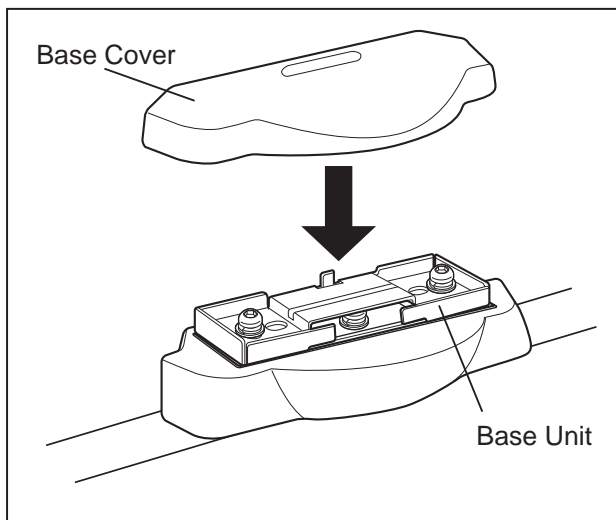

After removing the stay and the bar, leaving only the base unit on the vehicle, apply the base cover to the base unit.