

Installation Instructions

Before using the Mounting hooks, carefully read the installation instructions as well as the installation instructions for basic carrier systems, and follow all usage instructions. After reading the installation instructions, keep it in a safe place along with the installation instructions for basic carrier systems. If you are to give the mounting hooks to a third person, provide the installation instructions to ensure safe installation and usage.

For INNO dedicated ski & snowboard carriers, read the carrier installation instructions to determine proper mounting locations.

The TR Mounting hooks include the parts listed below. Verify that all of these parts are included in the carrier system you have purchased.

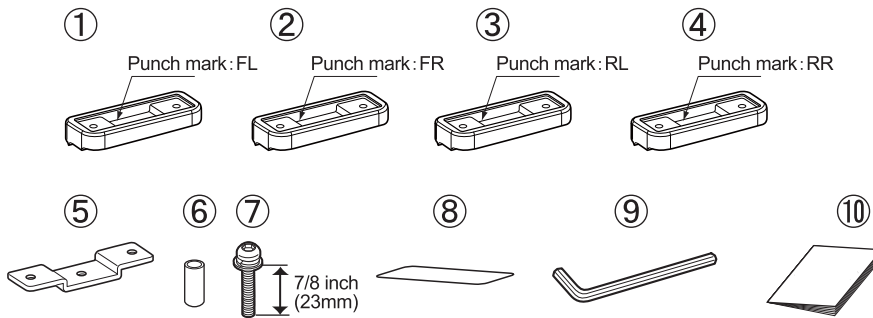

NOTE

The specifications or external appearance of this product or any of the genuine spare parts may be changed for improvement without prior notification.

No.	Part	Qty
①	Cushion base FL	1
②	Cushion base FR	1
③	Cushion base RL	1
④	Cushion base RR	1
⑤	Base bracket	4
⑥	Spacer	4
⑦	Bolt [M6x23]	4
⑧	Protection sheet	8
⑨	Hex Wrench [B=4]	1
⑩	Installation Instructions	1

Manufacturer	Vehicle model	Vehicle type	Model year	Loading conditions	
				Maximum Load Capacity	Bike
MAZDA	PROTAGE5		2002 - 2003	140 lbs (64 kg) (Load + Base rack + Attachments)	3

Vehicle preparations

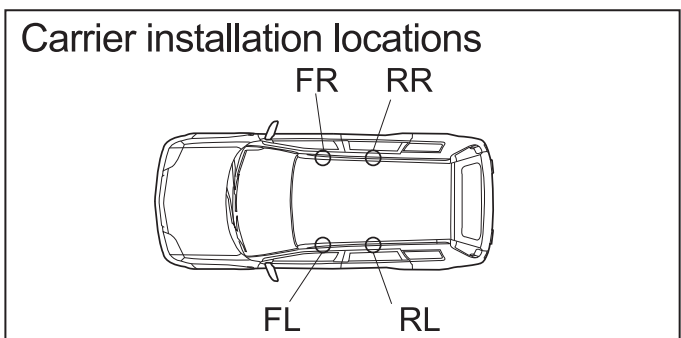
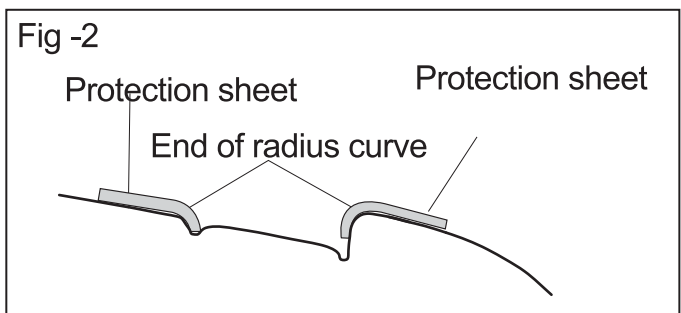
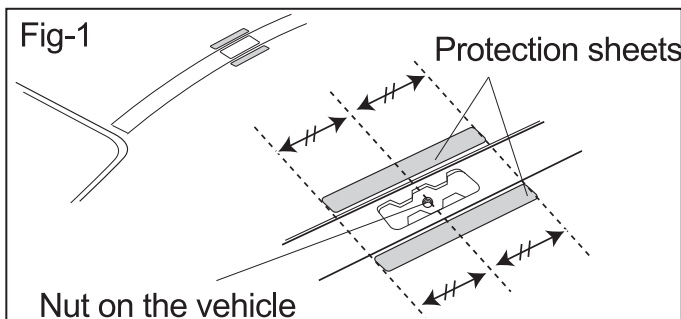
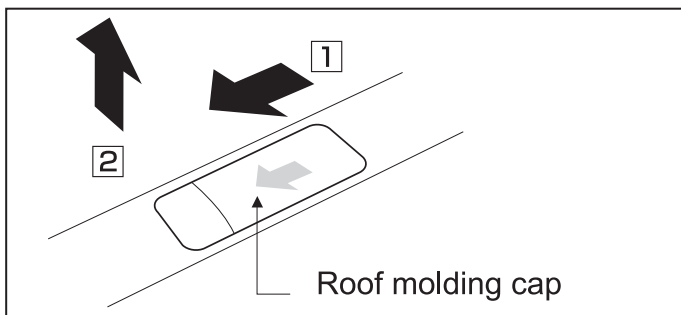
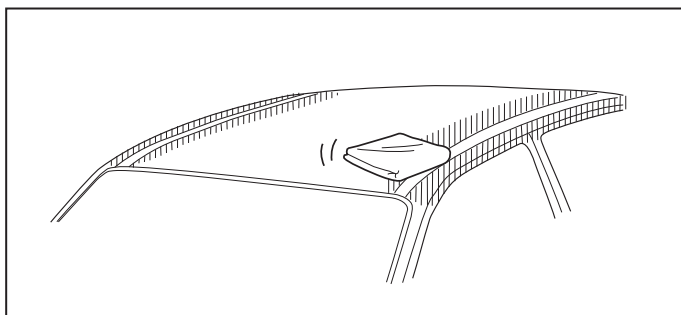

1 Cleaning the installation area on the vehicle

1

Wipe dirt and oil off the roof and moldings using diluted mild detergent, and then dry the wiped area.

*Shaded area in the figure.

NOTE

● Do not use organic solvents such as thinner or benzene to clean dirt and oil.

2

2 Removing the caps of the roof molding

Slide the roof molding cap to the direction 1, and then lift it up to the direction 2.

NOTE

● Keep the removed roof molding caps in a safe place. They will be reused when the carriers are taken off.

3

3 Applying the protection sheets

Apply the protection sheets to the area of roof molding on the roof. Apply each protection sheet aligning its center to the nut on the vehicle as shown in the Fig-1, and also place one edge of the protection sheet along with the end of radius curve on the roof molding (see Fig-2).

4

Attach the cushion bases to 4 locations on the vehicle where the carriers are to be installed.

NOTE

● There are 4 different kinds of cushion bases. Check the punch marks.

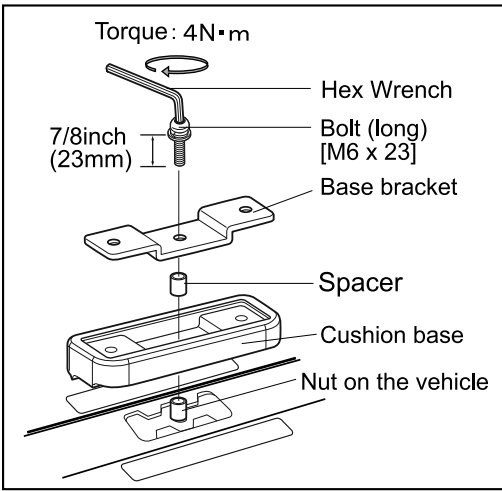

5 Attach them to the nut on the vehicle as shown in the figure. All base brackets (4 pcs.) are identical. The bracket is symmetrical with respect to the side-to-side axis; its installation orientation does not matter.

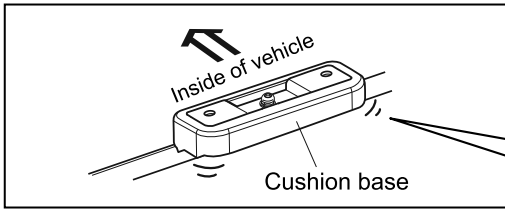

⚠ Caution

Fix the cushion base pressing it toward inside of the vehicle.

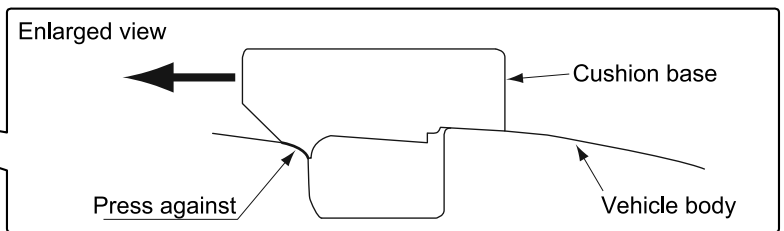

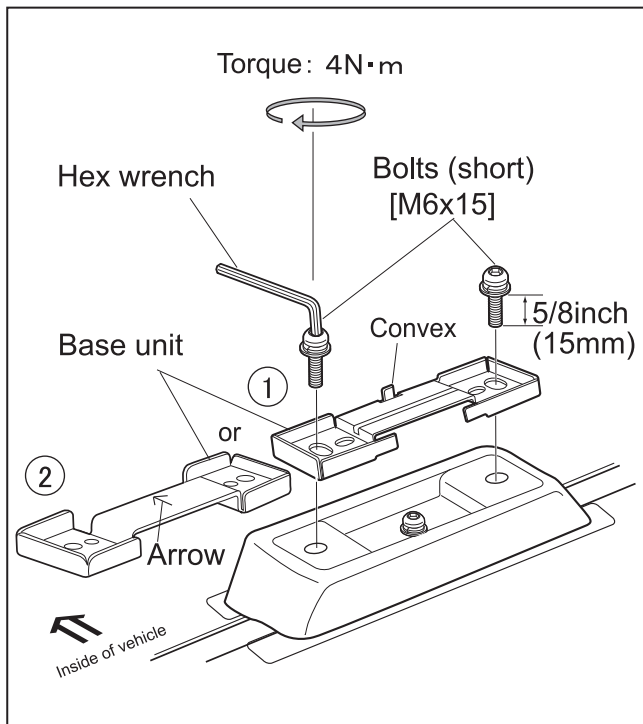

1 Place the base unit on the installed cushion base/base bracket, and using the Hex wrench, tighten alternately the right and left bolts (short) [M6 x 15] until the bolts are firmly tightened.

Base Unit ①

Place the base unit in a way that the convex section is on the inside of the vehicle.

Base Unit ②

The base unit must be placed as the arrow on the unit faces toward inside of the vehicle center.