

Installation Instructions

Before using the Mounting hooks, carefully read the installation instructions as well as the installation instructions for basic carrier systems, and follow all usage instructions. After reading the installation instructions, keep it in a safe place along with the installation instructions for basic carrier systems. If you are to give the mounting hooks to a third person, provide the installation instructions to ensure safe installation and usage.

WARNING

Install hooks correctly at specified positions according to the installation instructions herein and the installation instructions for the applicable carrier system. Installation positions of hooks depend on the vehicle type. If hooks are not installed at specified positions, the carrier may fall and cause accidents.

If inappropriate hooks are used, the carrier / attachment may fall and cause accidents.

Before driving the vehicle, rock the stays and bars in all directions to ensure that there is no looseness. Retighten any loose knobs or bolts.

Do not use these hooks for attachments of non-specified types.
The carrier may fall and cause accidents.

Observe the specified loading conditions.

Failure to observe the loading condition may cause the carrier to break or loosen and fall, resulting in accidents.

For INNO dedicated ski & snowboard carriers, read the carrier installation instructions to determine proper mounting locations.

The TR Mounting hooks include the parts listed below. Verify that all of these parts are included in the carrier system you have purchased.

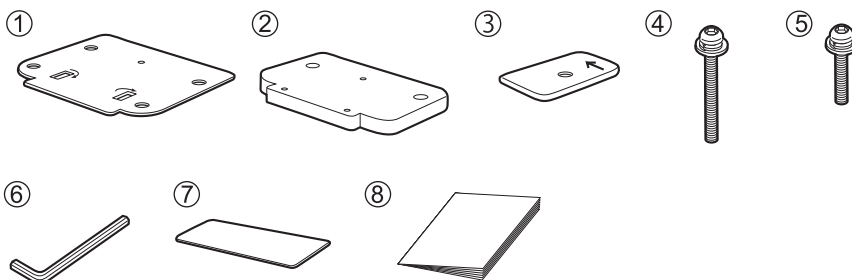

No.	Part	Qty
①	Base Plate	4
②	Plastic Plate	8
③	Nut Plate	8
④	Bolt (long) [M6x35]	8
⑤	Bolt (medium) [M6x15]	8
⑥	Hex Wrench [B=4]	1
⑦	Base Sheet	4
⑧	Installation Instructions	1

NOTE

The specifications or external appearance of this product or any of the genuine spare parts may be changed for improvement without prior notification.

Manufacturer	Vehicle model	Vehicle type	Model year	Loading conditions	
				Maximum Load Capacity	Bike
BUICK	RAINIER	w/factory rack	2005 - 2005	100 lbs (45 kg) (Load + Base rack + Attachments)	2
CHEVROLET	TRAILBLAZER		2002 - 2009		
GMC	ENVOY		2002 - 2009		
ISUZU	ASCENDER		2003 - 2008		
OLDSMOBILE	BRAVADA		2002 - 2004		

Vehicle preparations

1 Clean the roof rail of the vehicle.

Parts preparations

2 Slide all the 2 genuine cross bars to the aftermost position of the vehicle.

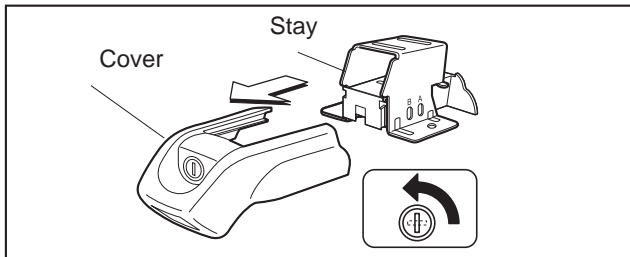

1 Unlock the key of your Basic Stay TR and remove the covers from the stays.

Installing System Carrier (IN-TR)

Follow the instructions below for the appropriate fit hook for your vehicle.

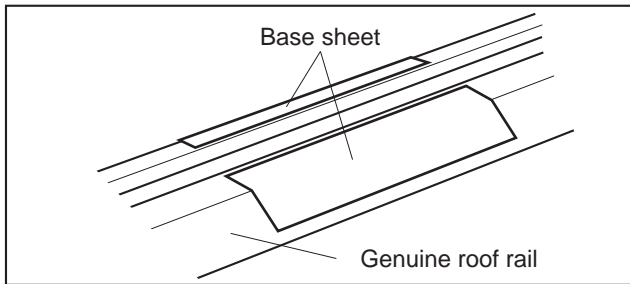

1 Prepare the bar set (sold separately).
After determining the mounting positions, paste the base sheets on the mounting positions of the genuine roof rail.
Determine the mounting positions in order for the load not to touch the rear gate when opening and closing.

Reference

This product is mountable at any positions on the genuine roof rail. However, be sure to keep at least 600mm between the front and the rear carriers.

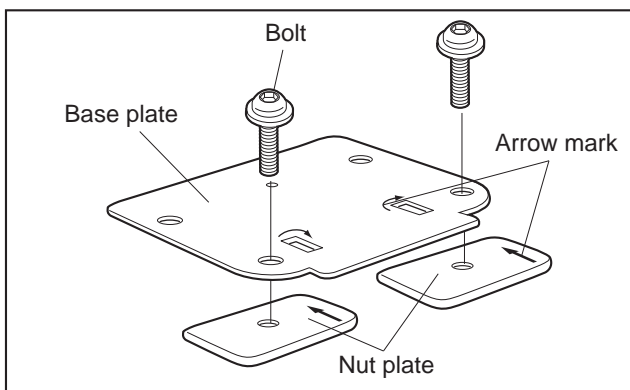

2 Loosely screw together the nut plate and the base plate using the bolt [M6x15mm].
Be sure that the arrow marks on the base plate and the nut plate are facing up.

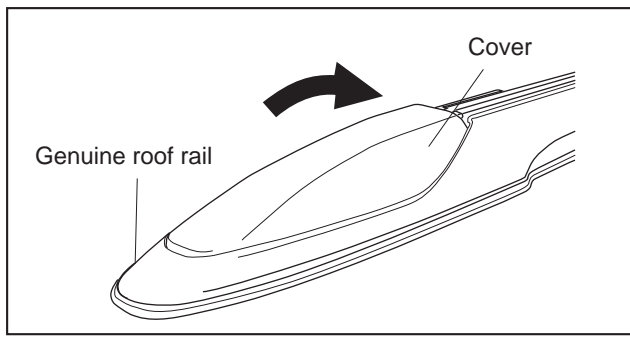

3 Open the cover on the front of the roof rail.

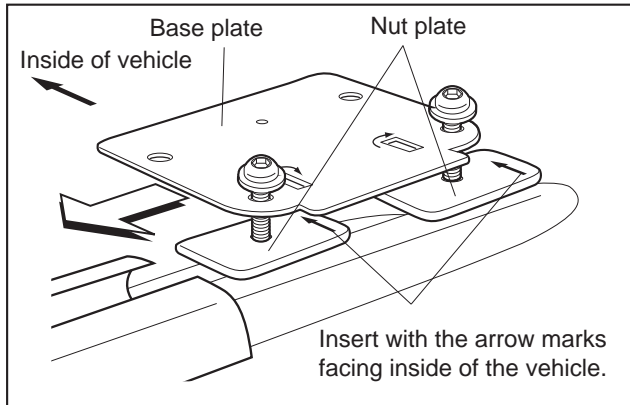

4 From the front of the roof rail, slide the loosely assembled base plate and insert the nut plate into the groove of the roof rail as illustrated. Be sure to insert the nut plate with the arrow marks facing the inside of the vehicle.

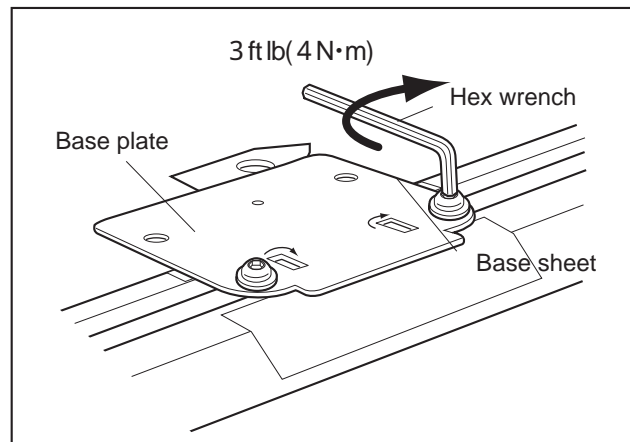

5 While slightly raising the base plate, slide it to the position where the base sheet is attached, and tighten it with the included hex wrench until it is firmly fixed.

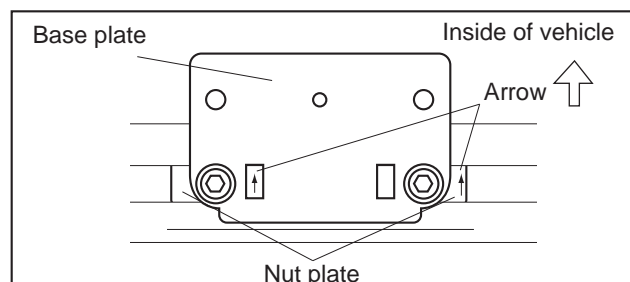

6 Seeing from above, verify that the arrows are facing toward inside of the vehicle.

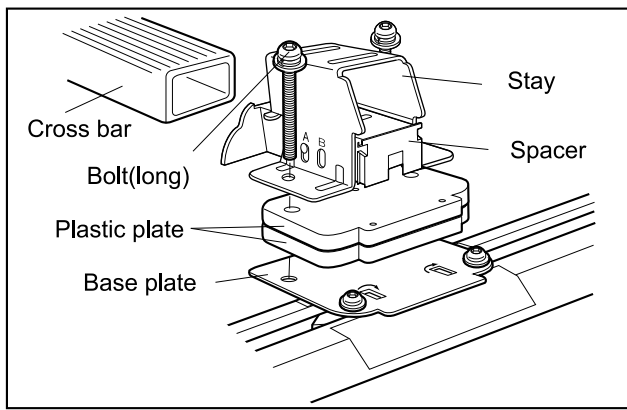

- 7** Place 2 plastic plates on the base plate. Place the stay upon the layers of plastic plates and base plate and loosely fix all of them together using 2 long bolts [M6x35mm] as illustrated. Place the cross bar through this assembled stay. Verify that the flat surface of the plastic plate is facing up and that the screw holes are aligned on the 2 plates.

Reference

- The surface of the cross bar with 8 grooves must face up.

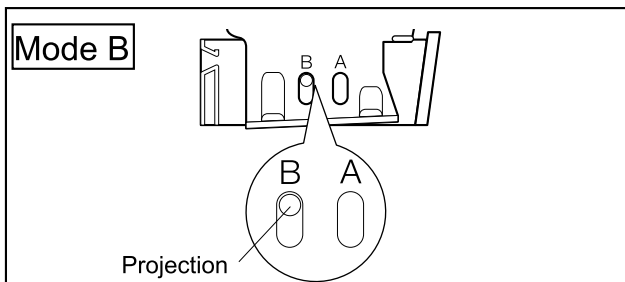

Slide the spacer so that the projection is positioned at the B mode.

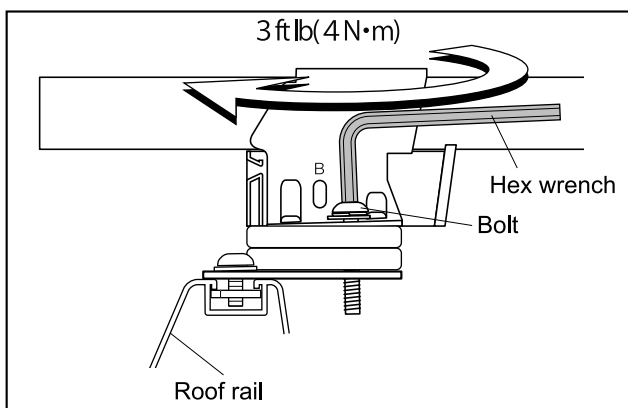

- 8** Tighten the left and right bolts alternately with the included hex wrench until they are firmly fixed, and fix the stay to the roof rail.

Reference

- Tighten bolts loosely with hands first, and tighten further using the Hex wrench.

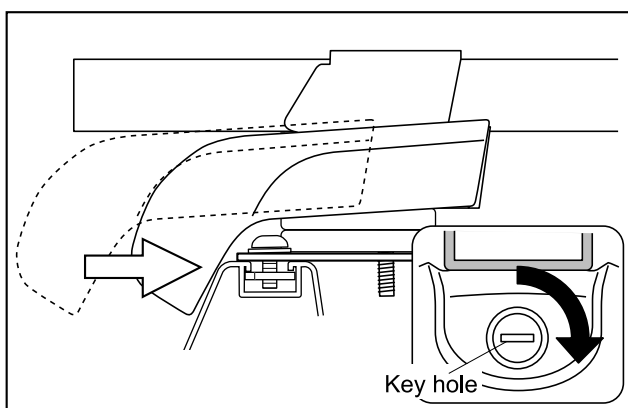

- 9** Close the cover.

- 10** Insert key and turn right to lock.

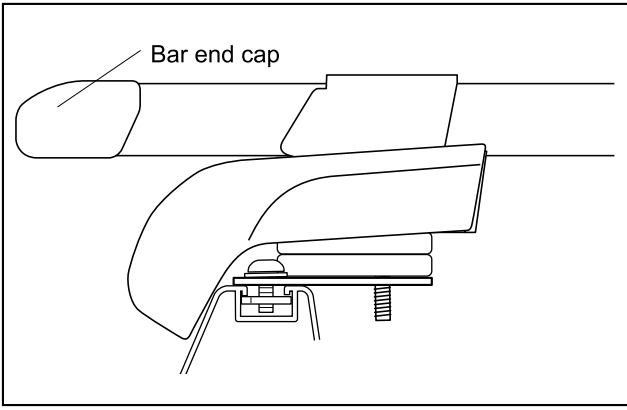

11 Place the bar end cap (supplied in the bar set).

12 Repeat the procedure to install all 4 stays.

After installation

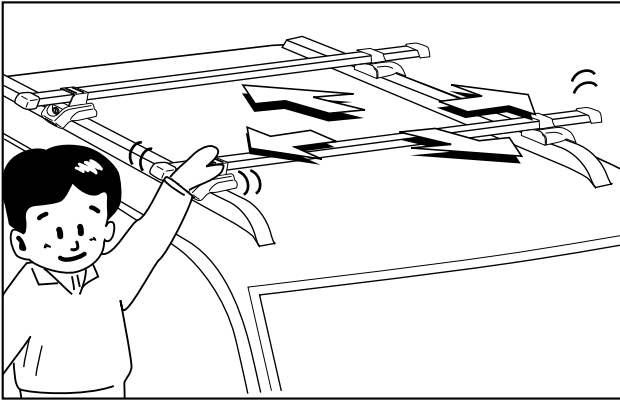

Warning

● Before driving, shake the installed stays and bars in order to check that all 16 bolts are securely tightened. If loosely screwed bolts are found, tighten them immediately. Loose bolts may lead to separation of stays, attachments and the load due to wind pressure and vibration while driving, resulting in serious injuries and/or accidents.

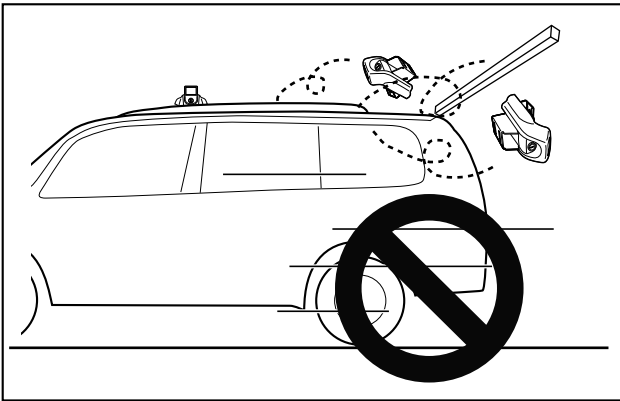

Warning

● Always use the key lock to secure the carrier. The locks are an extra safety measure preventing racks from coming loose which may result in serious injuries and/or accidents.

