



IN-AD IN-SD IN-MD Basic Carrier System Installation Instructions

US

Care and Storage

- 1 Wash any mud off the carrier system. Use a damp towel to wipe away dust and dirt. Do not use any thinner or solvents to clean any part of the carrier system.
- 2 After cleaning carrier, check for any of the following:
 - 1) Worn screw threads
 - 2) Key deformation
 - 3) Holder deformation
 - 4) Cracks in any of the components of the carrier system.
- 3 Store all components of the carrier system together in one place to prevent any component from being lost. Avoid storage in areas subject to direct sunlight, high temperature or excessive humidity.

Information on genuine repair parts

The following genuine repair parts are available for the carrier system. Specify the part number when ordering any part from the store where you purchased your system.

Note

- The specifications and external appearance of the carrier system and genuine repair parts are subject to change without prior notice in the interest of product improvement.

IN-AD

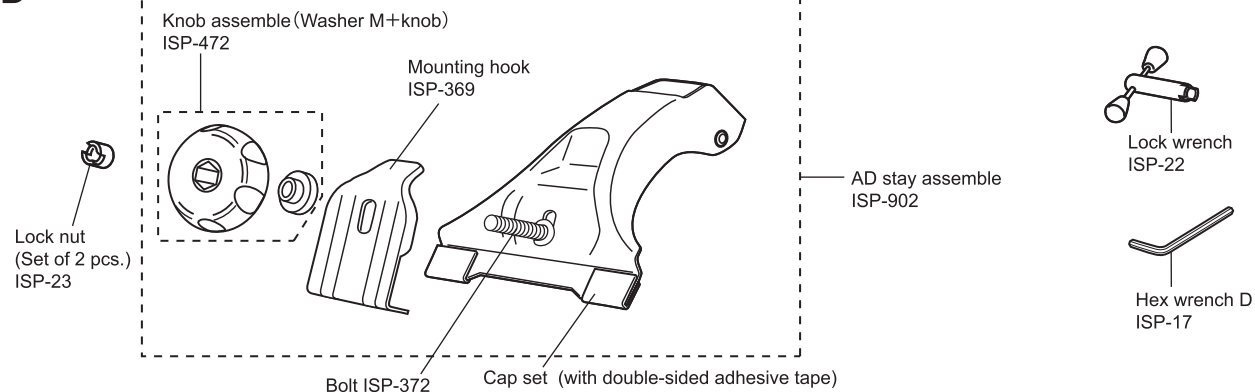

IN-SD

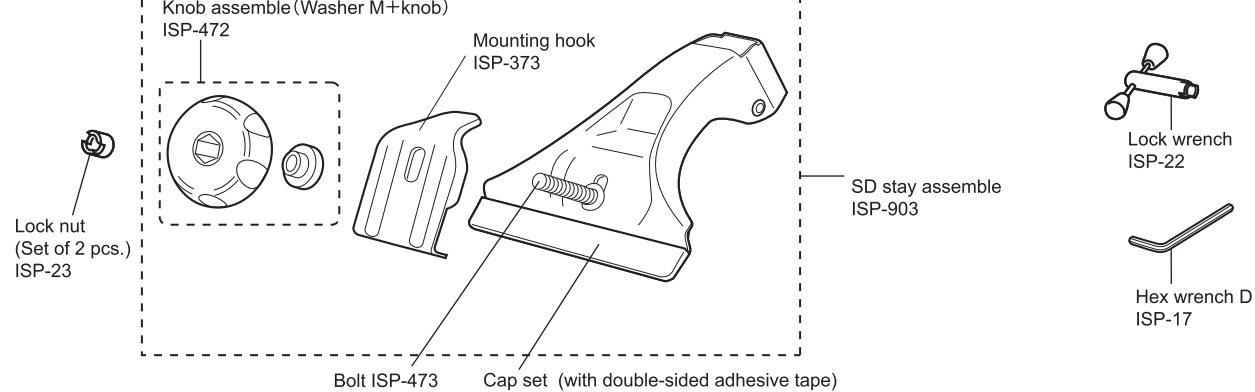

IN-MD

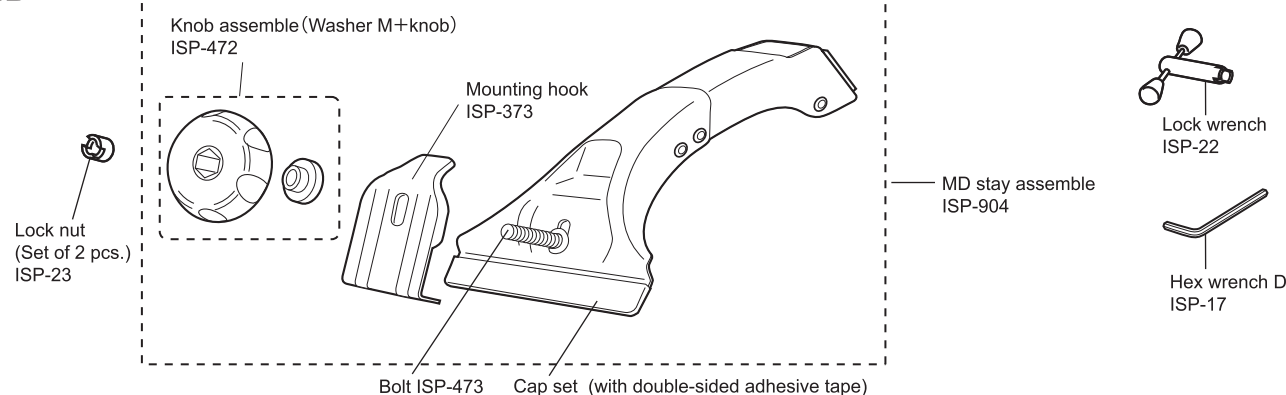

IN-AD IN-SD IN-MD Basic Carrier System Installation Instructions

US

The following Installation Instructions explain how to properly install and use IN-AD, IN-SD, IN-MD carrier system stays. After reading this manual, keep it in a safe place along with the instructions for other components in your Inno carrier system.

The IN-AD Basic Carrier System includes the parts, components and items shown below. Verify that all of these parts, components and items are included in the carrier system you have purchased.

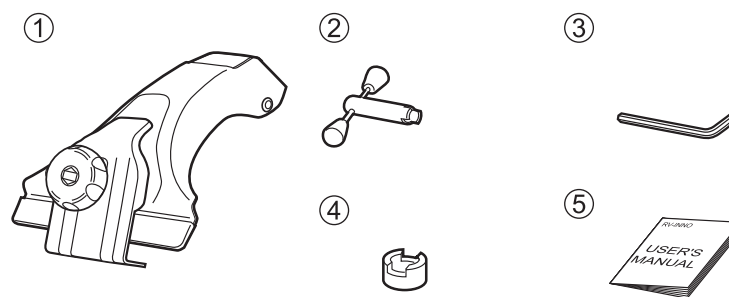

No.	Contents	#OF PIECES
①	BASIC STAY	4
②	LOCK WRENCH	1
③	HEX WRENCH	1
④	LOCK NUT	4
⑤	INSTALLATION INSTRUCTION	1

The IN-SD Basic Carrier System includes the parts, components and items shown below. Verify that all of these parts, components and items are included in the carrier system you have purchased. In the event any of these parts, components or items is missing, contact our service center as listed at the end of this manual.

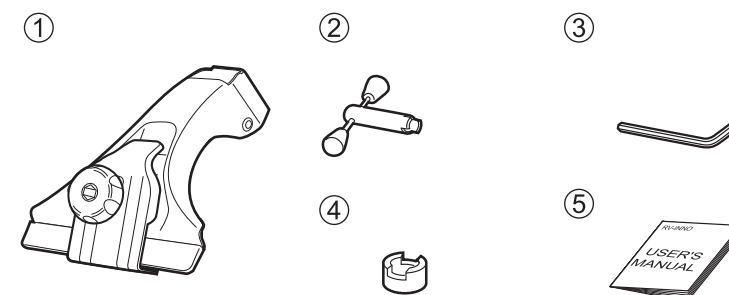

No.	Contents	#OF PIECES
①	BASIC STAY	4
②	LOCK WRENCH	1
③	HEX WRENCH	1
④	LOCK NUT	4
⑤	INSTALLATION INSTRUCTION	1

The IN-MD Basic Carrier System includes the parts, components and items shown below. Verify that all of these parts, components and items are included in the carrier system you have purchased. In the event any of these parts, components or items is missing, contact our service center as listed at the end of this manual.

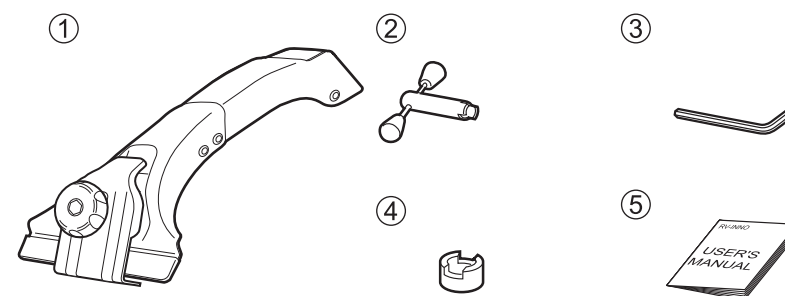

No.	Contents	#OF PIECES
①	BASIC STAY	4
②	LOCK WRENCH	1
③	HEX WRENCH	1
④	LOCK NUT	4
⑤	INSTALLATION INSTRUCTION	1

1 Loosen width-adjust screw on stay using hex wrench. Pass a bar through stay.

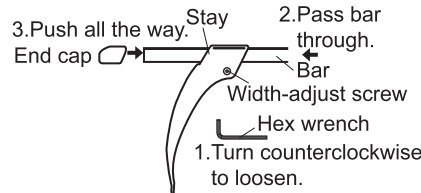

2 Install end cap onto bar and push it all the way. Do not apply too much force, as end cap may deform.

Note
Stay set doesn't include bar. Purchase a pair of basic bar of appropriate size by referring Fitting guide available at store.

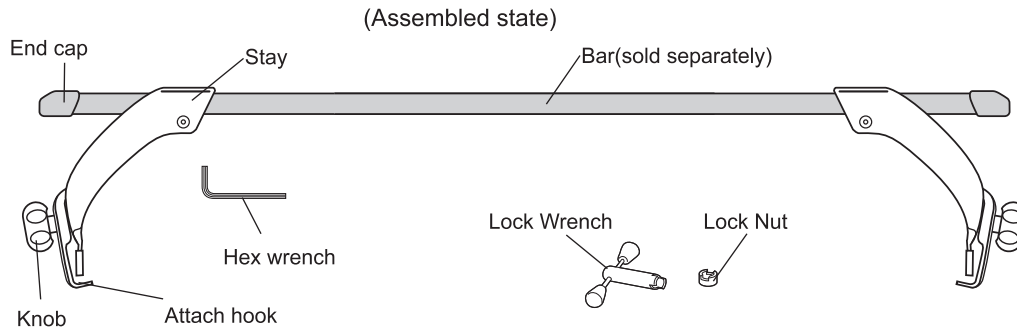

3 ① Place pre-assembled carriers on roof at desired positions.

② Distance between front and rear carriers should be at least 60 cm (23.6"). Distance may depend on load. Read instructions for each attachment.

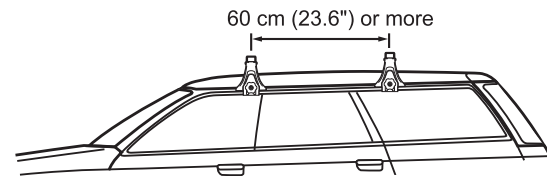

4 Insert stay into gutter, attach hook onto gutter, and tighten knob loosely over washer M.

CAUTION
Orient washer M correctly.

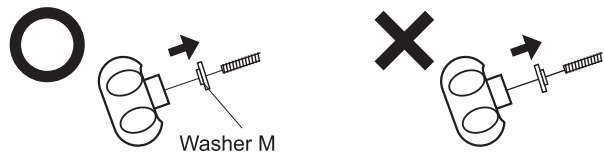

※Pay attention to knob/washer orientations.

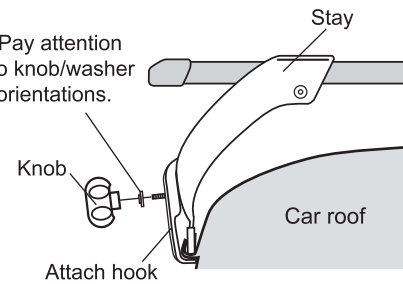

5 Adjust right and left bar ends to uniform length and securely tighten width-adjust screws on right and left stays using hex wrench.

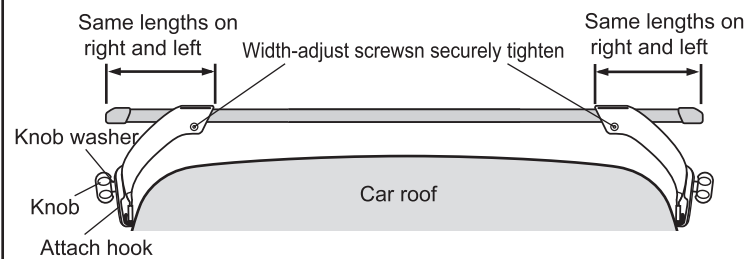

6 Securely tighten hook via knob.

CAUTION
● Carrier system may come off if not tightened securely.
● Do not apply grease or lubricant to bolt. Carrier may be damaged due to overtightening or come off due to loose bolt.

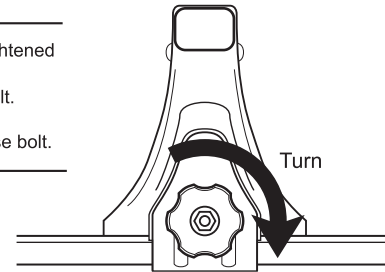

How to use lock wrench/nut

- With carrier installed, check if knob is securely tightened.
- Loosely install lock nut onto bolt by hand. Pay attention to orientation of nut.
- Apply lock wrench to nut and turn clockwise to tighten securely.
- Verify knob does not turn by hand.

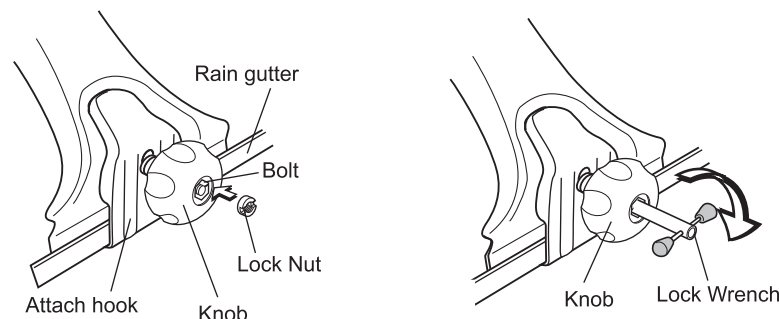

Before using the Carrier System, carefully read these guidelines as well as the installation and usage instructions for all the components that make up the carrier system. After reading these guidelines, keep them in a safe place with the instructions for the rest of the carrier system. If you give the Carrier System to a third person, provide this manual to ensure safe installation and usage.

⚠ Precautions

	<p>The carrier system's compatibility with an automobile is determined by the type of stay used. Moreover, certain automobiles require the use of a carrier base and mounting hooks. Be sure to consult the FIT GUIDE, which is available at your dealer.</p>	<p>Other manufacturer's attachment systems</p>	<p>This Carrier System is specially designed for INNO attachments only. Do not use the system in combination with any other manufacturers' products.</p>
	<p>The mounting position, loadable cargo and maximum carrier capacity vary by vehicle type. Be sure to read "Mounting Methods by Vehicle Type" in the Installation Instructions for the Mounting Hooks.</p>		<p>When using the Carrier System, avoid driving at excessively high speeds. Do not make hard starts, unnecessarily sharp turns, abrupt maneuvers or emergency braking. In case you have to perform a sharp turn, abrupt maneuver or emergency braking, always check afterwards to see that the carrier system and cargo remain secure.</p>
	<p>Do not attempt to modify the carrier system.</p>		<p>Always check to see that the carrier and cargo are secured in place after driving continuously at high speeds, in adverse weather conditions, or when driving over rough roads.</p>
	<p>Always use the key lock to secure the carrier. Failure to do so may allow the carrier to come off, resulting in an accident.</p>		<p>Check the fastening knobs and bolts, width-adjustment screws and any other mounting hardware on a periodic basis to see that they are securely tightened.</p>
	<p>Exercise caution when opening or closing the sunroof, hatch or tailgate. Failure to do so may cause the sunroof, hatch, gate or rear spoiler to hit the carrier and/or cargo.</p>		<p>Always remove the carrier system before running your car through a car wash.</p>
	<p>Do not concentrate the cargo in one area. Doing so may damage the carrier and/or cargo.</p>		<p>Mount the carrier system to your vehicle in a well-lit, open space on flat, stable ground.</p>