

FUTURA *AUTO*

Operating manual

Translation of the original instructions

D449934XA

vers. 2.0

CE

EN



INDEX

USE OF THE MANUAL.....	1
GENERAL WARNINGS.....	4
1 MACHINE DESCRIPTION	5
1.1 MAIN OPERATING PARTS	6
1.2 SAFETY	7
1.3 TECHNICAL DATA.....	8
1.4 ACCESSORIES PROVIDED.....	9
2 HANDLING.....	10
2.1 PACKING.....	10
2.2 UNPACKING.....	10
2.3 HANDLING THE MACHINE	10
3 MACHINE INSTALLATION AND PREPARATION.....	11
3.1 CHECKING FOR DAMAGE.....	11
3.2 ENVIRONMENTAL CONDITIONS.....	11
3.3 POSITIONING	11
3.4 SEPARATE PARTS	12
3.4.1 Tablet stand and tablet.....	12
3.4.2 Power pack and lead	13
3.4.3 Fixing bracket	13
3.5 WORK STATION DESCRIPTION	14
4 TABLET REGULATION AND USE	15
4.1 CHOICE OF LANGUAGE.....	15
5 CLAMPS	16
5.1 CLAMP FOR FLAT KEYS WITH STANDARD CUTS - 01VA.....	16
5.1.1 Use of the shoulder gauge.....	17
5.1.2 STOP positions (key stop)	17
5.2 CLAMP FOR TRACK KEYS - 01RA.....	19
5.2.1 FITTING THE KEY	19
5.3 REMOVING / FITTING CLAMPS 01VA AND 01RA.....	21
5.4 REMOVING/FITTING THE 106/107 JAWS ON CLAMP 01RA	21
5.4.1 FITTING OPTIONAL JAWS INTO THE 01RA CLAMP	22
5.5 USING TRACER 07T.....	23
5.6 TRACER 06T.....	23
6 CLEANING	24
7 MAINTENANCE	25
7.1 OPERATIONS	25
7.2 ACCESS TO REAR COMPARTMENT	25
7.3 CYLINDRICAL CUTTER AND/OR TRACER POINT REPLACEMENT	26
7.4 TRACER 07T REPLACEMENT.....	26

7.5	CHECKING AND REPLACING FUSE	27
7.6	BATTERY REPLACEMENT.....	28
7.7	ACCESS TO THE UPPER COMPARTMENT.....	29
7.8	REPLACING THE ELECTRICAL CONTACT BRUSH	30
7.9	REPLACING THE ELECTRICAL CONTACT BRUSH SET	30
8	DISPOSAL	31
9	ASSISTENZA.....	32
9.1	HOW TO REQUEST SERVICE	32
10	SOFTWARE OPERATING GUIDE.....	33
11	ELECTRICAL DIAGRAMS	35

USE OF THE MANUAL

This manual has been drawn up by the Manufacturer and is an integral part of the machine literature. The manual gives information that is obligatory for the operator to know and which makes it possible to use the machine safely.

User's Manual

This user's manual is provided because it is essential for proper use and maintenance of the machine. The manual must be kept carefully throughout the life of the machine, including the decommissioning stage. Keep in a dry place close to the machine where it is always to hand for the operator.



IT IS OBLIGATORY to read the manual carefully before using the machine.

Readers' characteristics

This manual must be read and its contents acquired by those who will use it.

Manufacturer's ID

FUTURA AUTO has an ID plate located on the back of the machine, showing the serial number.

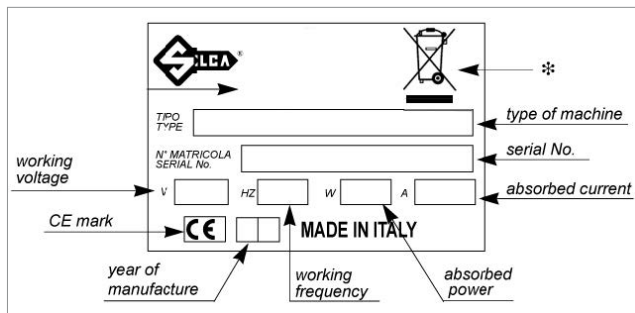

Fig. 1 - Silca

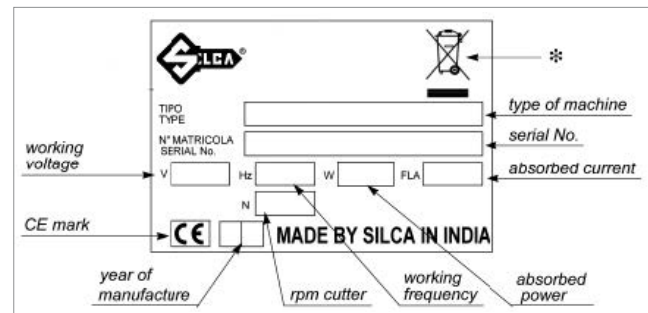

Fig. 2 - Minda Silca

(*) see chap. 8 DISPOSAL.

How to apply for after-sales service

Silca provides purchasers of FUTURA AUTO with After-Sales Service.

For the total safety of the operator and machine, any operation not described in the manual must be carried out by the manufacturer or in the special Service Centers recommended by Silca.

At the end of the manual there is a list of manufacturers' and authorized Service Centre addresses.

The warranty card attached to the machine covers free repairs or replacement of faulty parts for 24 months from the date of purchase*. All operations must be agreed by the user with Silca or the Service Center.

* Damage caused by negligence or wrong use of the machine by the user will null the warranty.

TERMINOLOGY

For those inexperienced in the subject of keys and key cutting, below is an illustration of the most frequently used terms:

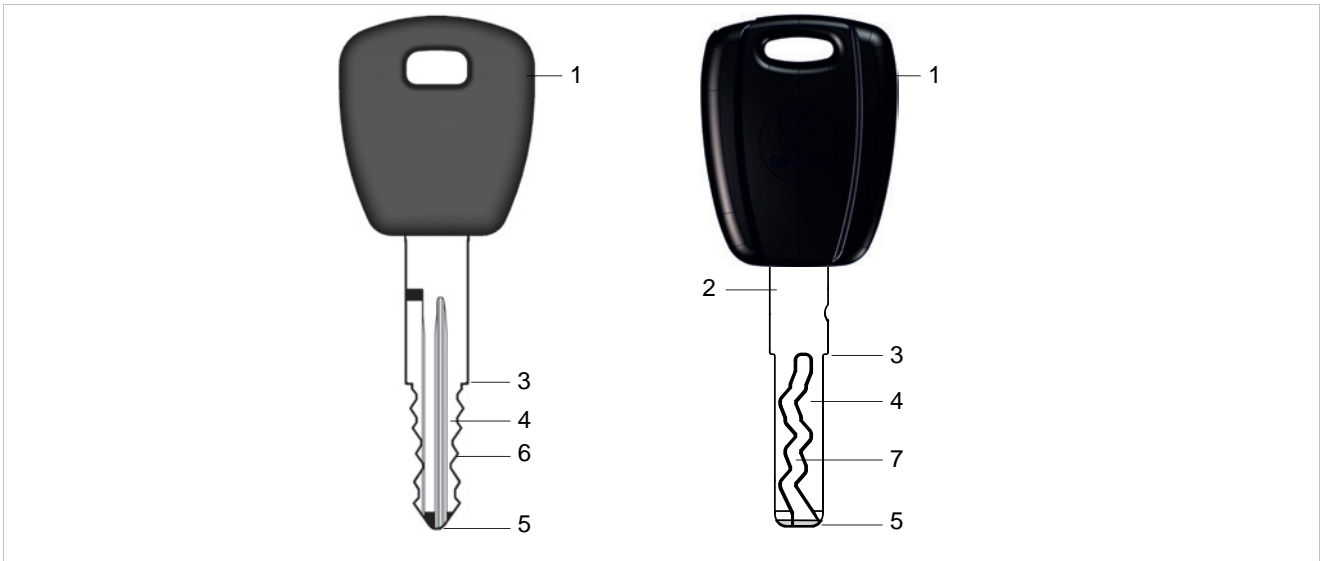

Fig. 3



- | | |
|------------------|---------------------|
| 1) Head | 5) Tip |
| 2) Neck | 6) STANDARD cutting |
| 3) Shoulder stop | 7) TRACK cutting |
| 4) Blade | |

ATTENTION: anodised aluminium keys, plastic keys or any other key without electrical conductivity CANNOT BE decoded and cut!

GRAPHICS IN THE MANUAL

	
<p>Pay attention</p>	<p>Obligation to read the manual</p>

GRAPHICS ON THE FUTURA AUTO KEY-CUTTING MACHINE

		
<p>Do not clean with compressed air</p>	<p>Obligation to read the manual</p>	<p>Adhesive label Mass - RPM</p>

GENERAL WARNINGS

FUTURA AUTO is designed to the principles of European Standards (CE).

Right from the design stage solutions have been adopted to eliminate hazards for the operator in all the stages of use: handling, regulation, use and maintenance.

The materials used in manufacture and the components employed in using FUTURA AUTO are not dangerous and ensure that the machine complies to current standards.

Silca S.p.A. has also experimented and applied numerous technical solutions that allow the key-cutting machine to optimize the quality of the cut keys.

To guarantee maintaining these results over time, please follow the instructions below:

- **Observe the procedures described in this manual;**
- **Always use Original Silca Tools as they are designed to make the best of Futura AUTO and provide quality key-cutting;**
- **Use Silca/Ilco key blanks, made with top quality materials;**
- **Have the key-cutting machine checked periodically by an authorized Silca After-Sales Service Center;**
- **Always use Silca Original Spare Parts. Beware of imitations!**

NORMAL USE

FUTURA AUTO is a key-cutting machine and must be installed and used according to the rules and specifications established by the manufacturer.

The key-cutting machine must be used only by skilled personnel (professional use).

The FUTURA AUTO key-cutting machine is designed for use on business or industrial premises (e.g. hardware shops, key cutting centers, etc...).

Any other use different from that indicated in this manual will cause the forfeiture of all customers' rights to make claims on Silca S.p.A. and may be an unknown source of hazard for the operator or third parties.



ATTENTION: Negligent use or failure by the operator to observe the instructions in this manual are not covered by the warranty and the manufacturer declines any responsibility in such cases.

ATTENTION: Anodised aluminium keys, plastic keys or any other key without electrical conductivity CANNOT BE decoded and cut!

RESIDUAL RISKS

No further risks will arise when properly using the FUTURA AUTO machine.

SAFETY REGULATIONS

- **Always disconnect the machine when it is not in use or when performing maintenance operations.**
- **Check the electrical wiring periodically; replace any wires that show signs of wear.**
- **Always work with dry hands free of grease or oil.**
- **Never tug on the electricity supply lead and make sure it is not in contact with oil or other liquids, sharp objects or heat. Never remove the grounding pin from the plug. Check that the ground wire is connected properly.**
- **Do not use the machine in dangerous environments (wet or damp).**
- **All visitors, especially children, must stay at a safe distance from the machine and must never come into contact with the electric wiring. This equipment should not be used where children may be present.**

1 MACHINE DESCRIPTION

FUTURA AUTO is an electronic machine operating on 3 axes with controlled movement. Accurately studied, it adds a high degree of cutting precision to operating speed and ease of use.

FUTURA AUTO operates only when connected to a TABLET containing a Silca program.

FUTURA AUTO uses the tracer to decode vehicle keys with standard cuts and track type cuts.

It can cut keys (in ferrous materials in general, brass, silver nickel, etc.) having:

- **STANDARD cuts**
- **TRACK cuts**
- **Special cuts (e.g. Ford Tibbe - with optional accessory)**
- **Cuts on tubular keys (with optional accessory)**

FUTURA AUTO is used to cut the following types of keys:



Fig. 4



Fig. 5

ATTENTION: Anodised aluminium keys, plastic keys or any other key without electrical conductivity CANNOT BE decoded and cut!

1.1 MAIN OPERATING PARTS

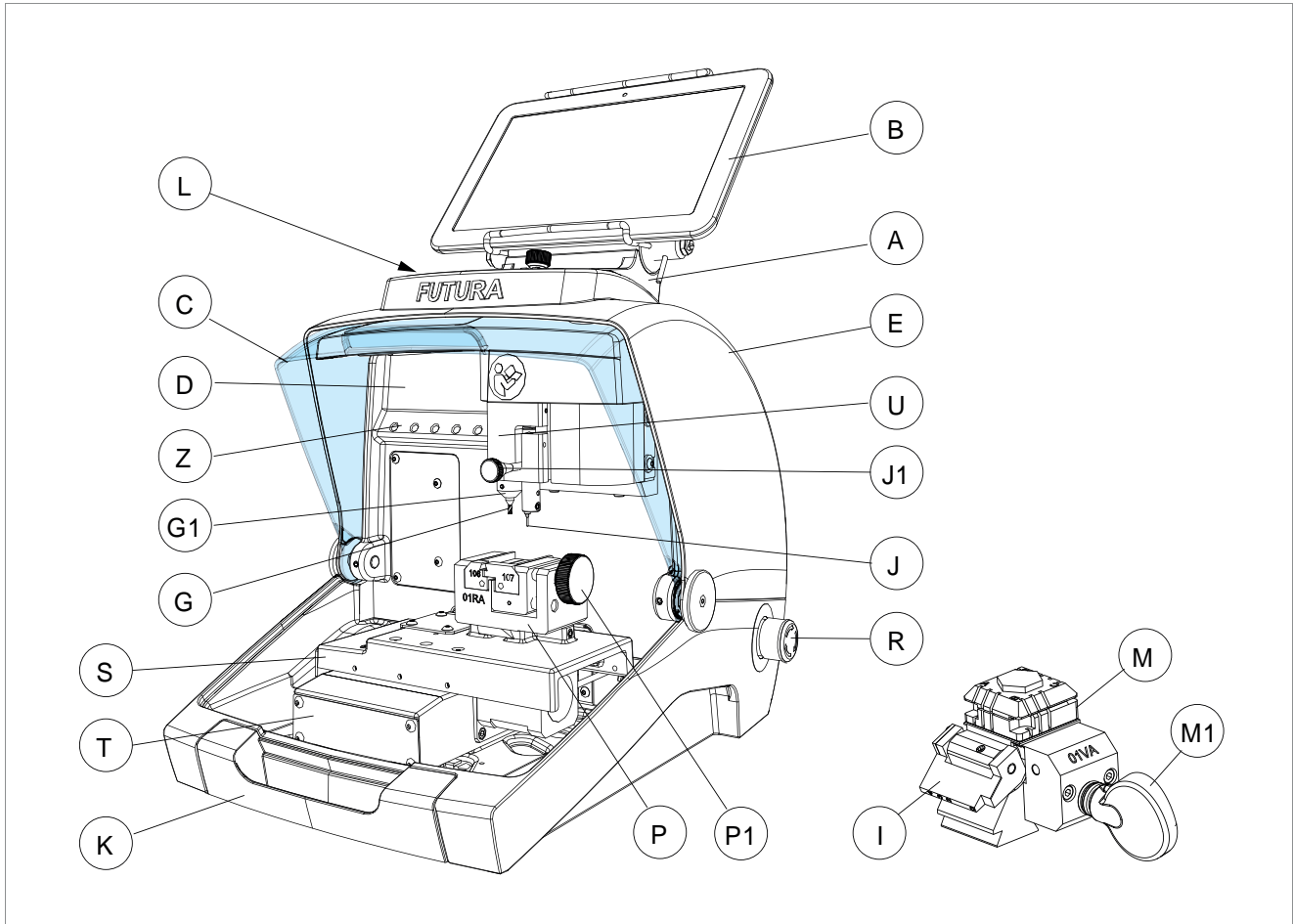

Fig. 6

- A - Tablet stand
- B - Tablet
- C - Safety shield
- D - Lamp
- E - Cover
- G - Cutter
- G1 - Cutter shaft
- I - Gauge (01VA clamp)
- J - Tracer 07T
- J1 - Tracer movement lever
- L - Tool compartment
- K - Swarf collection tray
- M - Clamp 01VA (Standard cuts)
- M1 - Clamp knob (01VA)
- P - Clamp 01RA (Track cuts)
- P1 - Clamp knob (01RA)
- R - ON/Emergency push button
- S - X axis carriage
- T - Y axis carriage
- U - Z axis carriage
- V - Ethernet port
- W - Power pack
- W1 - Power pack connector
- Y - USB port for Tablet charge
- Y1 - USB port standard
- Z - Tool holder

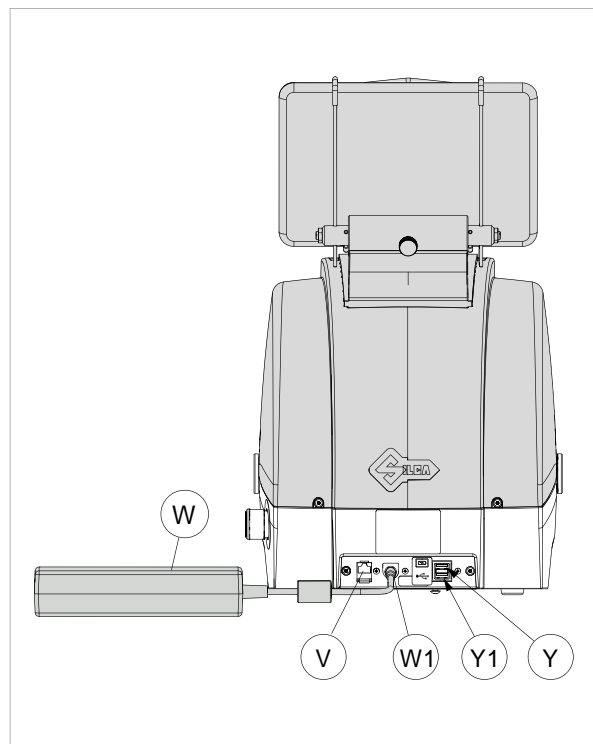

Fig. 7

1.2 SAFETY

FUTURA AUTO is entirely built in compliance to the Machine Directives. The operations for which it has been designed are easily carried out with no risk to the operator.

The adoption of general safety precautions and observation of the instructions provided by the manufacturer in this manual eliminate all human error, unless deliberate.

FUTURA AUTO is designed with features which make it completely safe.

- **Safety shield**

The protective shield is designed to cover the working parts as completely as possible, ensuring operator safety.

The shield (C) must be raised in order to fit keys for cutting or carry out other operations (Fig. 8).

Raising the shield by means of a microswitch will deactivate the operating and movement functions, including the cutter, and failed shield closing will be notified with a special message on the tablet.

To re-activate the work cycle, lower the shield and follow the instructions on the tablet.

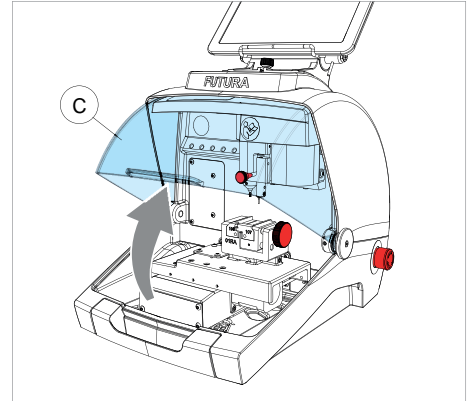

Fig. 8

- **Emergency stop**

Use the red emergency button (R) (Fig. 6), located on the right-hand side of the machine to stop the machine immediately in the event of serious malfunctioning or a hazard for the operator.

When the cause of the emergency has been eliminated, turn the button 45° clockwise to deactivate it.













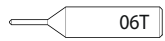
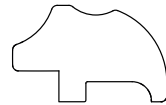

NOTE: the operator is responsible for keeping the area around the button clear so that it can be reached as quickly as possible.

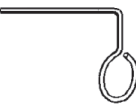
1.3 TECHNICAL DATA

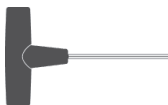
Electricity supply:	Machine: 24V d.c.- 5,5 Amp. - 130W Power pack: 90/264V a.c. - 50/60Hz - 220W MEANWELL GST220A24-R7B
Cutter motor:	24V d.c.
Cylindrical cutters:	01LW - 02LW - 06LW : carbide, coated 12L : in HSS Super Rapid steel
Tool speed:	Fresino cilindrico: 12100 rpm
Movement:	on 3 axes (with special bushes) driven by step motors (on rectified roller guides).
Clamp 01VA : (for standard cuts)	removable, with 4 universal sides for holding flat vehicle keys
Clamp 01RA : (for Track cuts)	removable and provided with interchangeable jaws (106-107)
Runs:	X axis: 30 mm Y axis: 50 mm Z axis: 27 mm
Dimensions:	width: 318 mm depth: 413 mm height with tablet and stand: 522 mm (without tablet and stand 340 mm)
Mass:	Kg. 20
Noise level:	sound pressure Lp(A) = - brass flat keys: 72.0 dB(A) - steel flat keys: 74.5 dB(A) - brass track keys: 74.0 dB(A) - steel track keys: 75.0 dB(A)

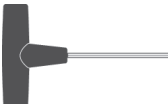
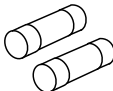
1.4 ACCESSORIES PROVIDED

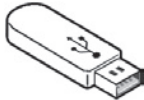
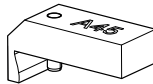
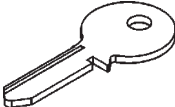
FUTURA AUTO comes with a set of accessories for its operation and maintenance (tools, hex wrenches...) supplied in a special tool kit comprising:

cutter 01LW 	cutter 02LW 	cutter 06LW 
cutter 12L 	tracer point 06T 	stop bar 01RA 
stop bar 	ø 1,2 mm steel pin 	ø 1,7 mm steel pin 
tip stop (Stop 4) 	"T" allen key 2,5 mm 	Allen keys set 1,5 ÷ 5 mm 
universal adapter 	"T" allen key 3 mm 	fuses 4 Amp.- delayed 
stylus touch pen 	USB pen (FAT32 format) 	adapter A45 Futura Auto 
template Z3 (regulating key) 	brush 	

Cutters and tracers on machine:

tracer point 07T



Separately:

fixing bracket:

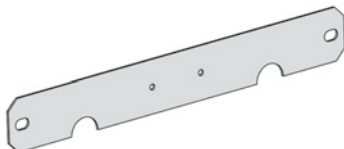

2 HANDLING

The FUTURA AUTO key-cutting machine is easy to handle and there are no special hazards involved in moving it.

The packed machine can be carried manually by one person.

2.1 PACKING

The packing for the FUTURA AUTO key-cutting machine ensures safe handling of the machine and all its components.

Packing comprises expanded plastic material wrapped around the machine.

The robust cardboard box in which it is placed and the nylon wrapping protect the machine even when stored for a long period.

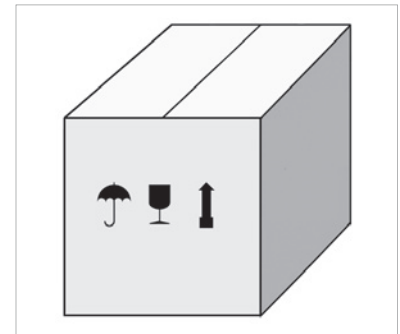

Fig. 9



Keep dry



Handle with care



Up

The symbols on the outside of the cardboard box give indications for transport.



ATTENTION: keep the complete packing for future machine transfers.

2.2 UNPACKING

To remove the machine from its packing:

- 1) Cut the strapping with scissors and remove.
- 2) Open the box carefully without damaging it.
- 3) Free the machine from the protective shells.
- 4) Check the contents of the packing, comprised of:
 - FUTURA AUTO key-cutting machine
 - clamp 01VA
 - documentation comprising: user's manual, spare parts sheet, specialist guide and warranty
 - tablet
 - tablet stand
 - power lead
 - power pack
 - tool kit
 - fixing bracket

2.3 HANDLING THE MACHINE

Once removed from its packing place FUTURA AUTO directly on the work bench; one person can easily perform this operation.



ATTENTION: lift the machine by holding onto the base. Never lift the machine by gripping the clamps, levers or other parts.

3 MACHINE INSTALLATION AND PREPARATION

Installation is the customer's task and does not require any special skills.

The key-cutting machine is supplied ready for use and does not need calibration except for the tools to be used and any additional jaws that are included with the machine; however, the operator is required to make certain checks and prepare the machine for use.

NOTE: the machine is shipped with a steel rod installed in the cutter shaft to prevent the allen screw from backing out during transit. REMOVE THE ROD AND INSTALL THE PROPER CUTTER PRIOR TO ATTEMPTING TO CUT A KEY!

3.1 CHECKING FOR DAMAGE

FUTURA AUTO is a solid compact machine and will not break if handling, unpacking and installation are carried out to the instructions in this manual. However, it is good practice to check that the machine has not been damaged.

3.2 ENVIRONMENTAL CONDITIONS

To make the most of the key-cutting machine, bear in mind the following environmental parameters: it is advisable for the area to be dry with good air circulation.

The optimum environmental conditions for machine operation are:

- temperature 10° C to 40°C;
- relative humidity: approx 60%.

3.3 POSITIONING

- 1) Place the key-cutting machine on a solid horizontal work bench suitable for the weight of the machine (20 Kg). The work bench should be approximately 100-120 cm high to facilitate access to the working parts. We recommend leaving at least 30 cm clearance behind and around the machine to ensure good ventilation and facilitate handling (Fig. 10).
- 2) Make sure machine voltage is suitable for the mains supply and that the latter is earthed with a differential switch.
- 3) Connect the power lead (power pack) to the machine (chap.3.4.2).

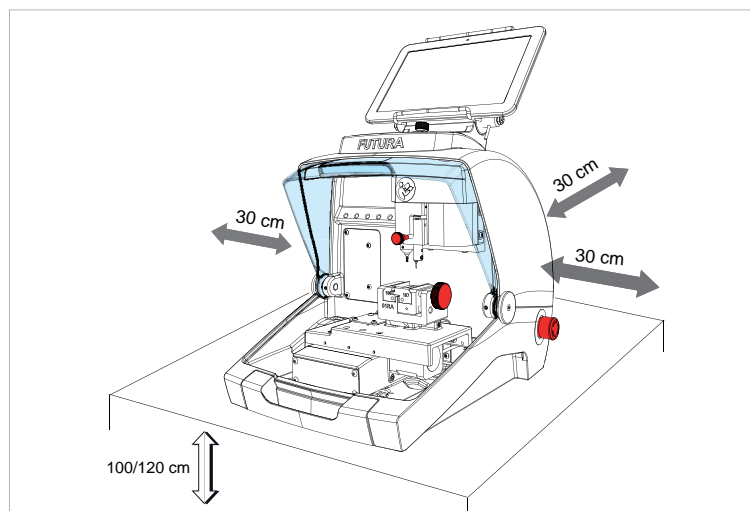

Fig. 10

3.4 SEPARATE PARTS

The machine packing also contains the following components, separately packed:

3.4.1 Tablet stand and tablet

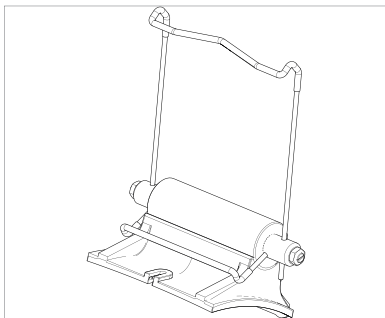

Fig. 11

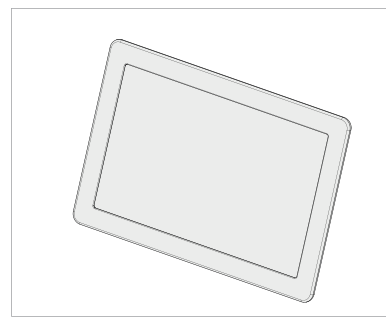

Fig. 12

These items are separate from the machine and must be unpacked and installed by the operator in the way described below:

- 1) Remove the 2 items from their packing.
- 2) Loosen the knob on top of the machine cover (Fig. 13).
- 3) Install the tablet stand so that the special profile fits into the slot on the machine cover (Fig. 14).
- 4) Screw down and tighten the knob to secure the tablet stand to the cover (Fig. 15).
- 5) Fit the tablet into its stand (Fig. 16).



Fig. 13

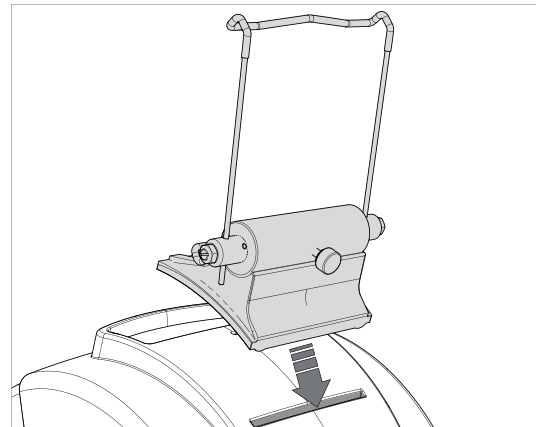

Fig. 14

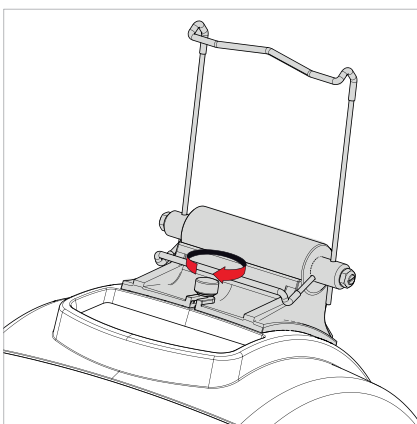

Fig. 15

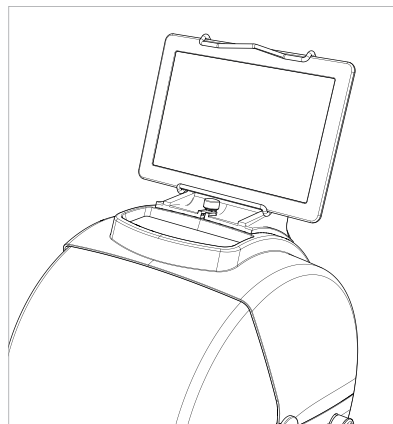

Fig. 16

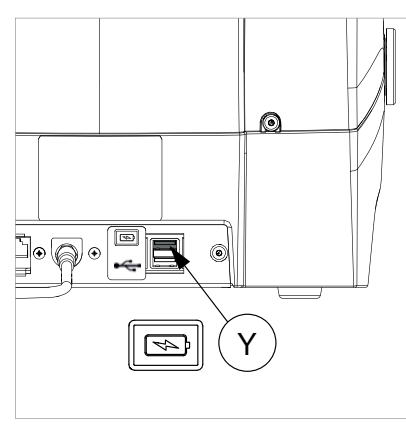

Fig. 17

- 6) Connect the tablet USB/Micro USB cable to the USB tablet port (Y) located on the back of Futura AUTO.

3.4.2 Power pack and lead

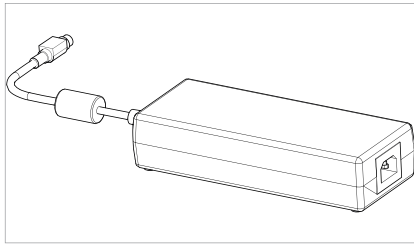

Fig. 18

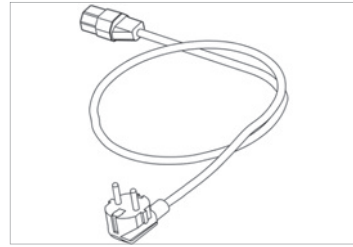

Fig. 19

Connect FUTURA AUTO to the power pack (W) and connect the latter to the power supply with the power lead (W2).

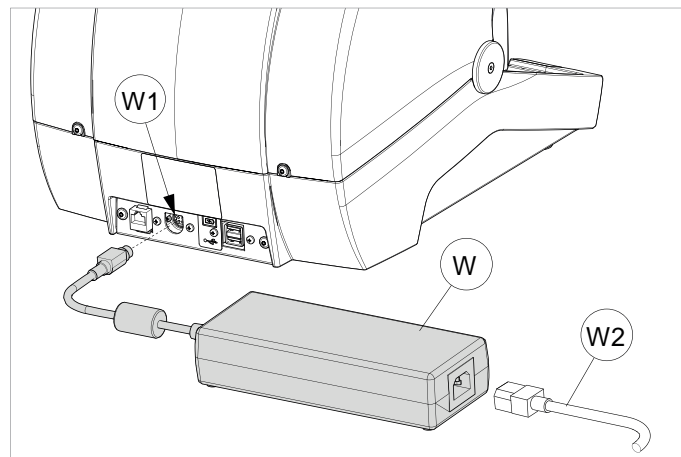

Fig. 20

3.4.3 Fixing bracket

If the key-cutting machine is transported and used on a vehicle, e.g. a van, it must be prepared as follows:

- 1) Turn off the machine and detach the power lead.
- 2) Remove the tablet holder and tablet.
- 3) Turn the key-cutting machine onto its back.
- 4) Connect the fixing bracket to the machine and secure with the 2 screws.
- 5) Return the machine to its upright position on the work top.

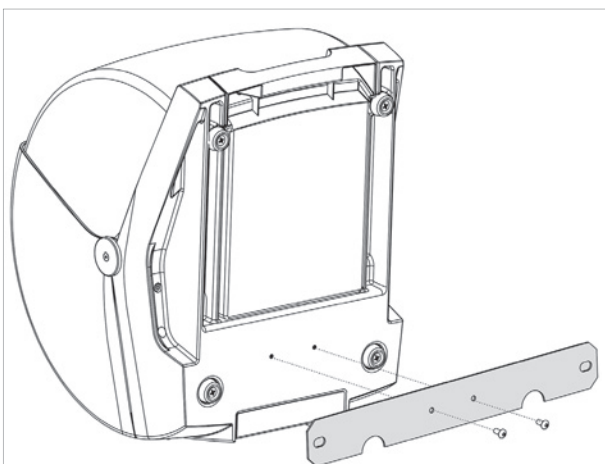

Fig. 21

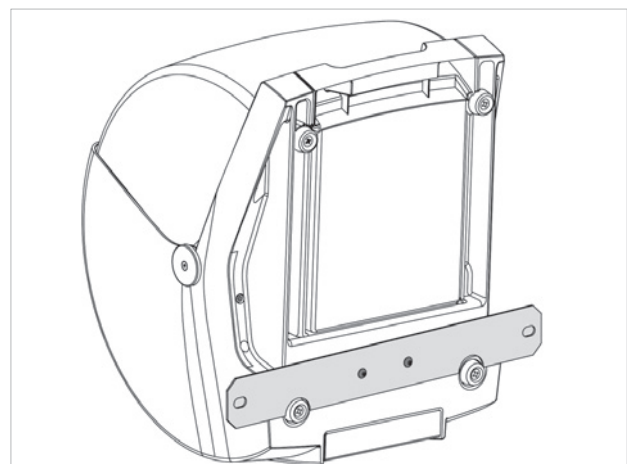

Fig. 22

3.5 WORK STATION DESCRIPTION

One operator is enough to operate the machine, which has the following operating parts:

- **General ON/OFF/emergency button (R)** located on the right-hand side of the machine
- **Clamp 01RA holding clamp for keys with track cuts (P)**
- **Clamp 01VA holding clamp for keys with standard cuts (M)**
- **Tablet (B)**
- **Tablet ON button (B1)**
- **Safety shield (C)**
- **Cutter (G)**

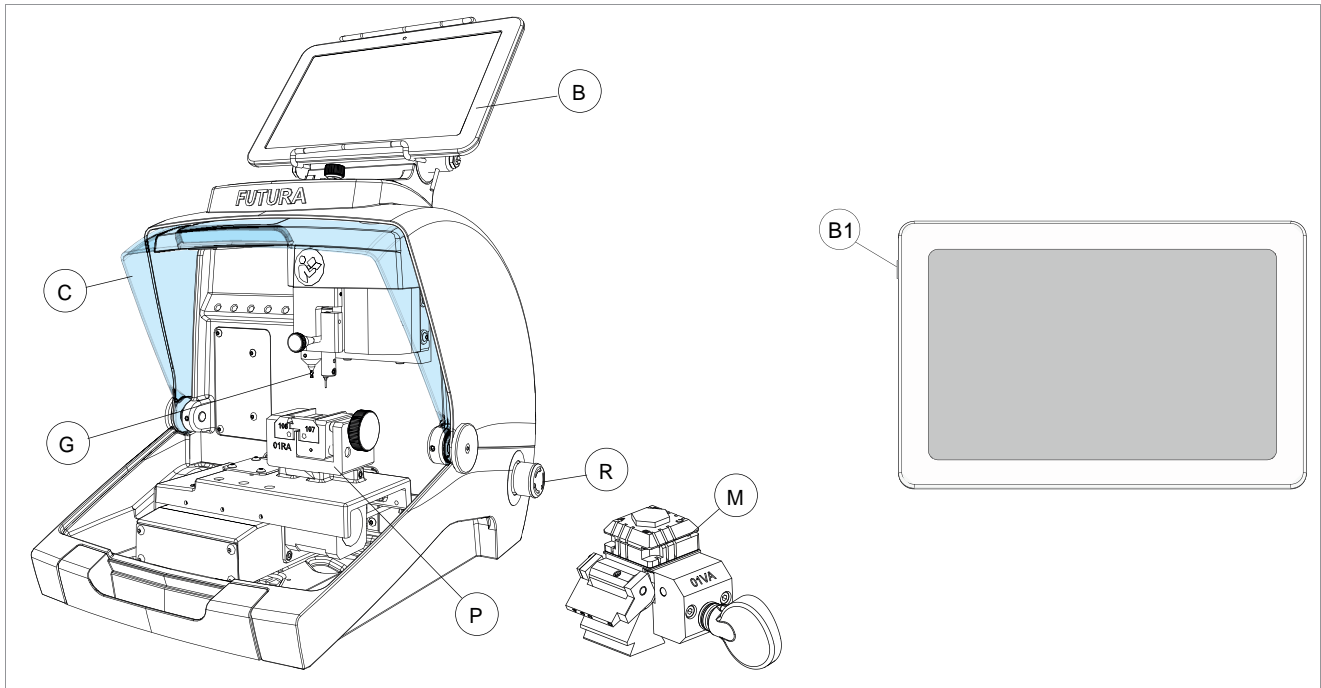

Fig. 23

MACHINE POWER ON

Rotate the red button (R) to turn on the machine.

4 TABLET REGULATION AND USE

- 1) Connect the tablet to a power source by means of its power pack in order to charge it (3 hours for the first charge). The tablet can also be charged connected to the specific USB port (Y) on the back of the machine (Fig. 17, pag.12).
- 2) Turn on the tablet by holding down the push button (B1) (Fig. 23) holding it down for a few seconds.

REGULATING TABLET INCLINATION

- 1) Loosen the knob (B2).
- 2) Incline the stand as required.
- 3) Tighten the knob (B2).

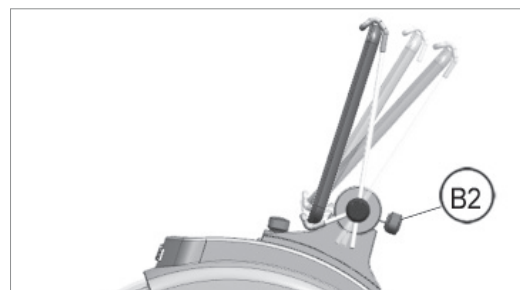
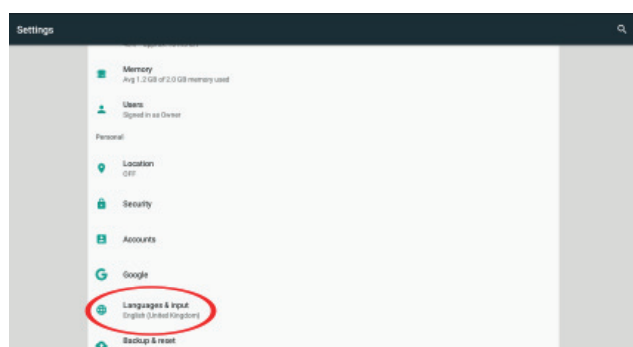



Fig. 24

4.1 CHOICE OF LANGUAGE



- 1) Select "Settings" .



- 2) Scroll the page.
- 3) Select Language & Input and then Language.
- 4) Select the required language, hold down and drag to position 1.
- 5) Select Silca Keyboard (if desired)
- 6) To quit 

- **For all software functionalities on board the Silca key-cutting machine, see the SOFTWARE OPERATING GUIDE on your tablet (Ch.10).**
- Further instructions are given in the quick guide for the tablet.

5 CLAMPS

5.1 CLAMP FOR FLAT KEYS WITH STANDARD CUTS - 01VA

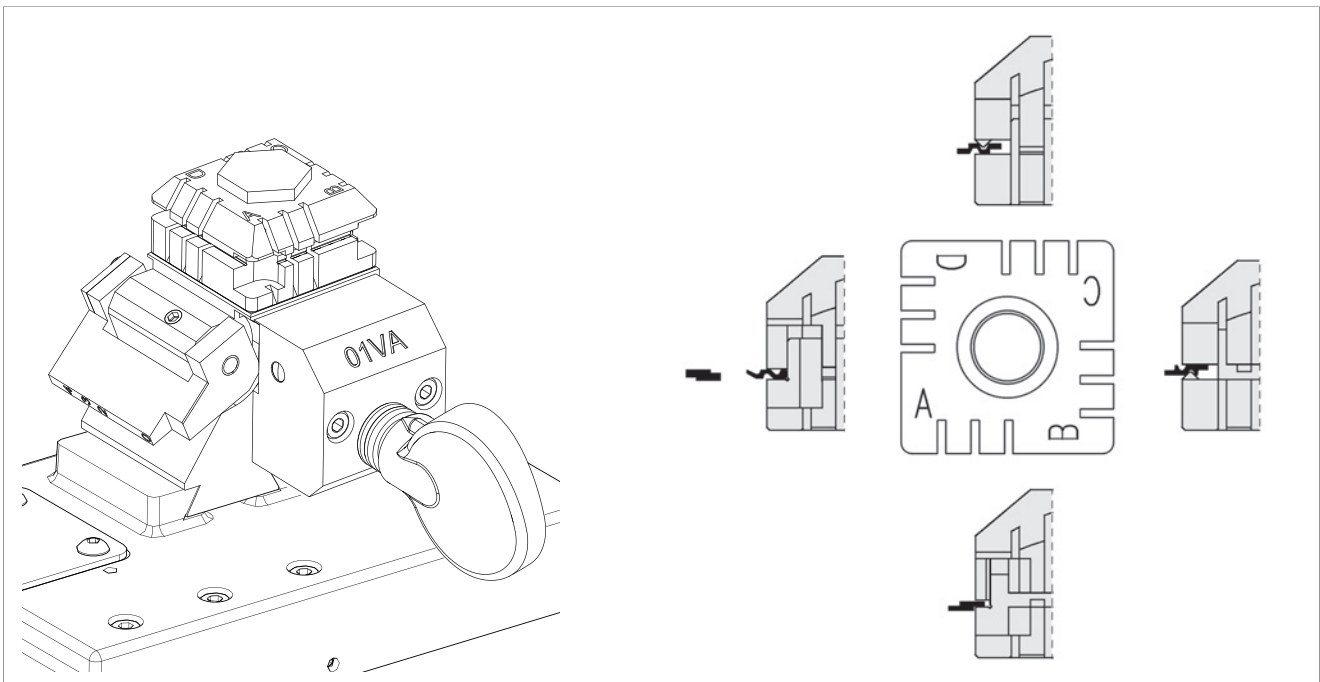

Fig. 25 - clamp 01VA

The use of one of the clamp sides is required, according to the type of key to be decoded and/or cut by copying or by code (Fig. 25). Positioning the correct side to be used is quick and easy. With the clamp jaws slightly open, turn the clamp by hand to position it as required, facilitated by a new special alignment system (Fig. 26).

The 4-sided clamp is used to secure keys firmly up against the back and on the profile.

- To copy keys (these can be locked on any of the clamp sides A, B, C or D), the user will decide which side is the most suitable.
- To decode a key you **MUST** use the clamp designated by the software.
- For code key-cutting the choice of clamp to use is established by the software.

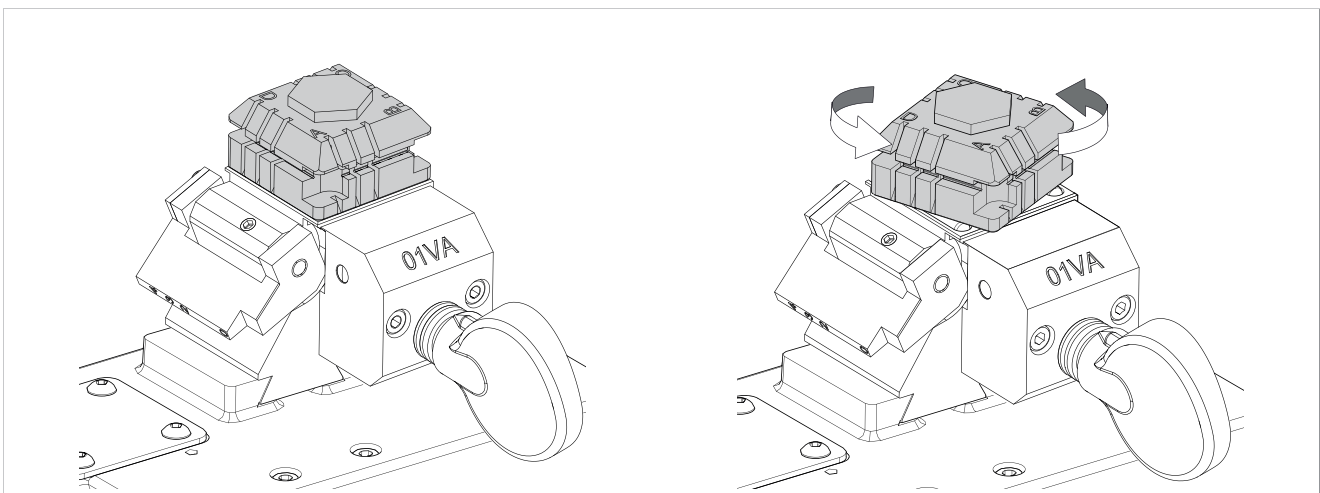

Fig. 26 - CLAMP ROTATION

5.1.1 Use of the shoulder gauge

The gauge is used to position flat vehicle keys with stop (Stop 0) (chap.5.1.2).

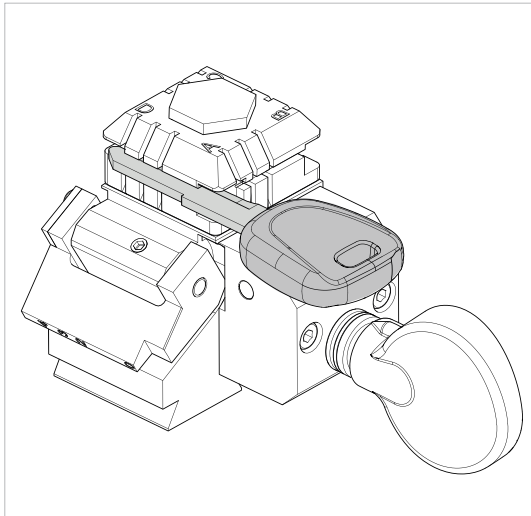

Fig. 27

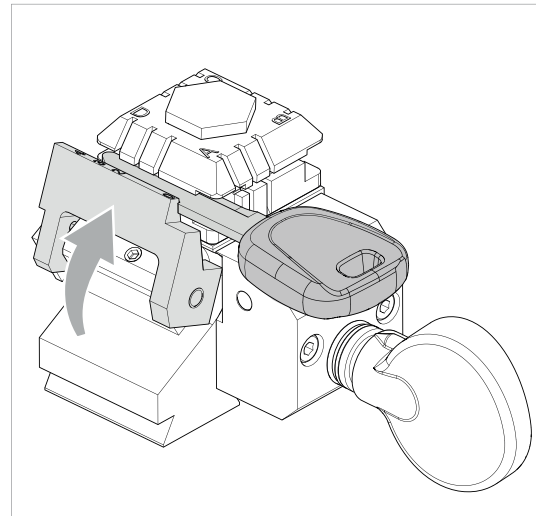

Fig. 28

Fit the sample key into the clamp with the stop up against the gauge (Fig. 28).

NOTE: *there is no need to lower the gauge manually.*

5.1.2 STOP positions (key stop)

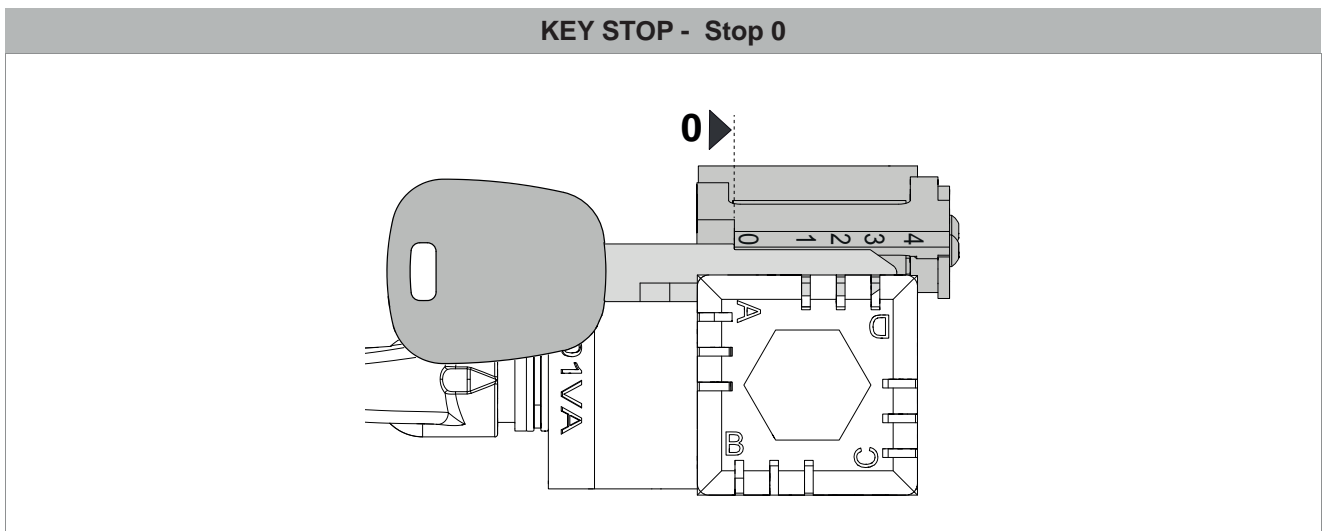

Fig. 29 - Stop 0

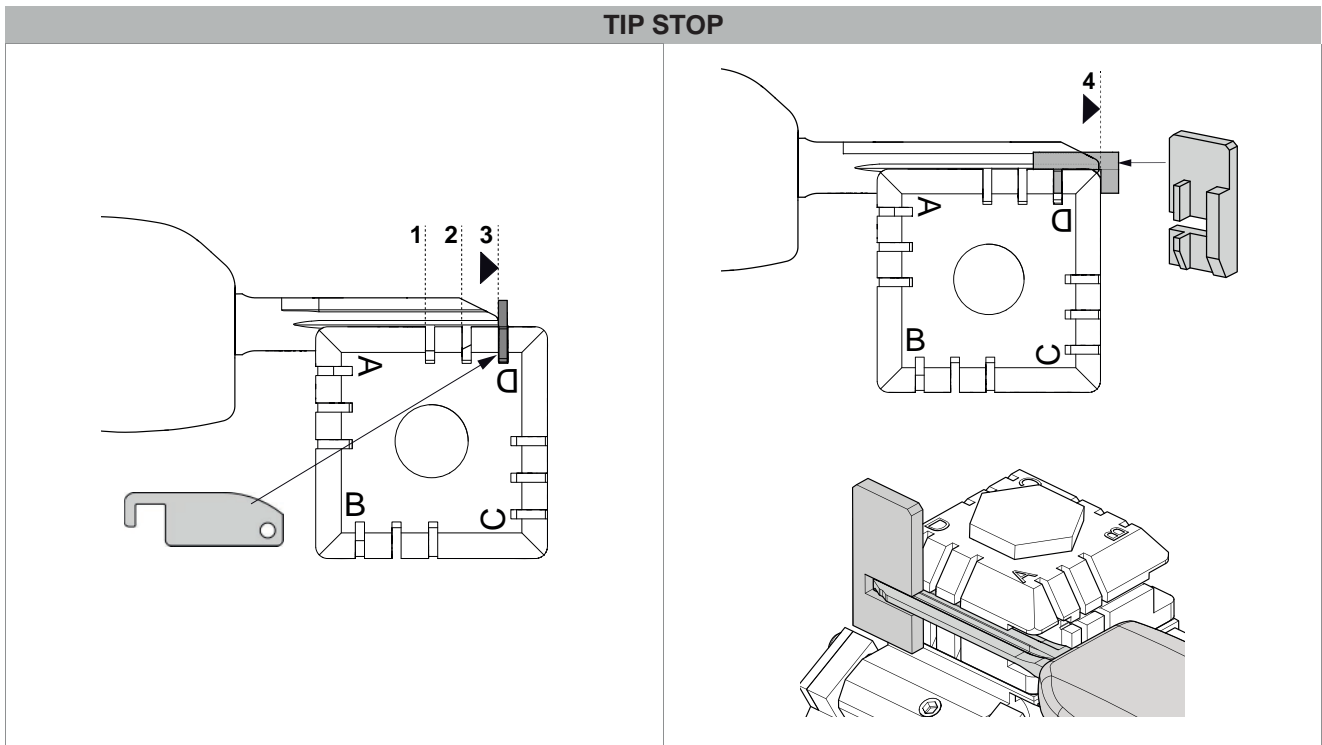

Fig. 30: Stop 1 - 2 - 3

Fig. 31: Stop 4

According to the length of the stem the following accessories are provided to install keys with tip stops (chap.1.4):

- **Stop bar (Fig. 30)**

For keys that need Stop 1, 2 or 3. Insert the bar into the grooves provided.

- **Tip Stop “Stop 4” (Fig. 31)**

For long keys that need Stop 4. Install as per Fig. 31.



ATTENTION: stop bar and tip stop must be removed before decoding or cutting operations.



ATTENTION: it is not necessary to apply force to close the clamp properly.

5.2 CLAMP FOR TRACK KEYS - 01RA

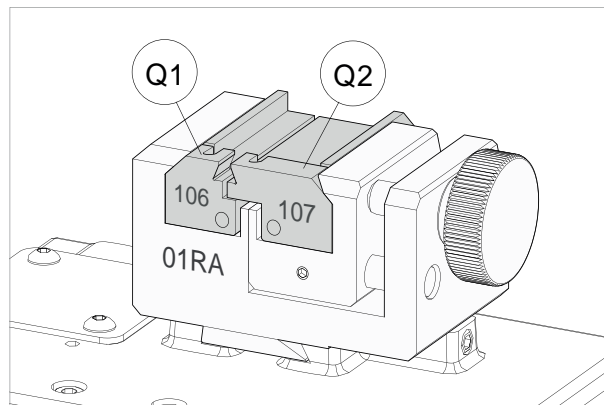

Fig. 32

According to the type of key to be decoded and/or cut, follow the instructions in the Silca tablet program regarding:

- **clamp**
- **use of jaws (Q1) and (Q2)**
- **clamp stop (Fig. 33 and Fig. 38)**

5.2.1 FITTING THE KEY

The clamp is designed to hold vehicle keys with track-type cuts and stop or tip reference.

- **KEYS WITH STOPS**

Position the key with the stops up against the special stop bar (Stop "0") (Fig. 33).

NOTE: if the stop bar is used, remove it before proceeding with decoding or cutting.

- 1) Insert the bar into the groove on the clamp and slide it to the left.
- 2) Insert the key to be cut, making sure it sits flat on the surface, and take the stop up against the bar (Fig. 33).
- 3) Tighten the knob (M) to secure the key.
- 4) Remove the bar.

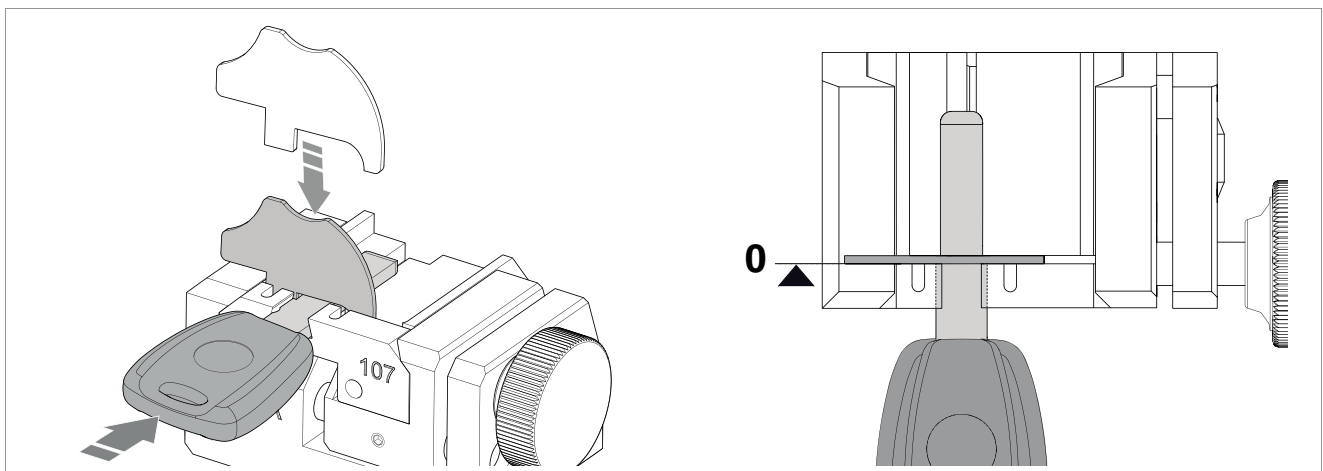

Fig. 33 - KEYS WITH STOPS

• **KEYS WITH STOP (eg. HU66...)**

To correctly align keys with stop (Stop 0) the A45 adapter (supplied) is required to be positioned in the 107 or 106 jaw (according to the type of the profile).

Insert the bar into the groove on the clamp and slide it to the left.

Insert the key to be cut, making sure it sits flat on the surface, and take the stop up against the bar (Fig. 37).

Tighten the knob (M) to secure the key; remove the bar.

ATTENTION: remove the stop bar before proceeding with decoding or cutting.

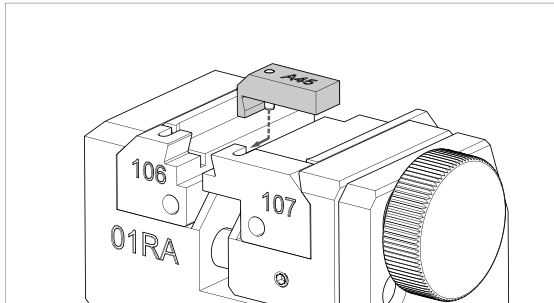

Fig. 34

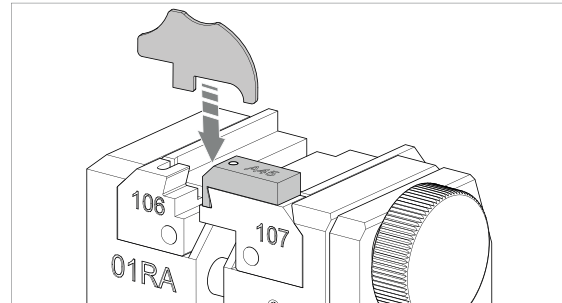

Fig. 35

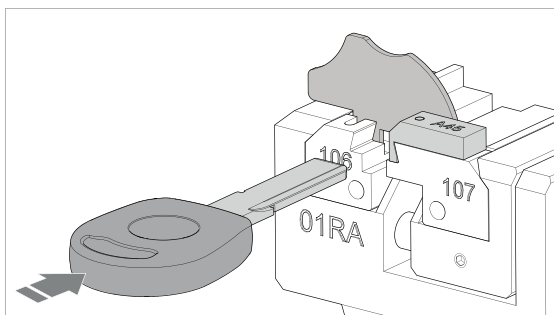

Fig. 36

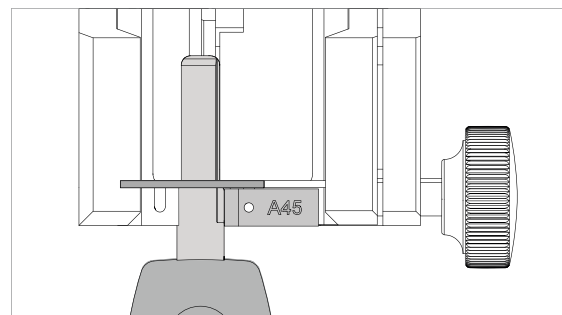

Fig. 37

• **KEYS WITH TIP REFERENCE**

Position the key as wished, bearing in mind that cutting (existing or to be done) must begin beyond the locking line/zone (Fig. 38).

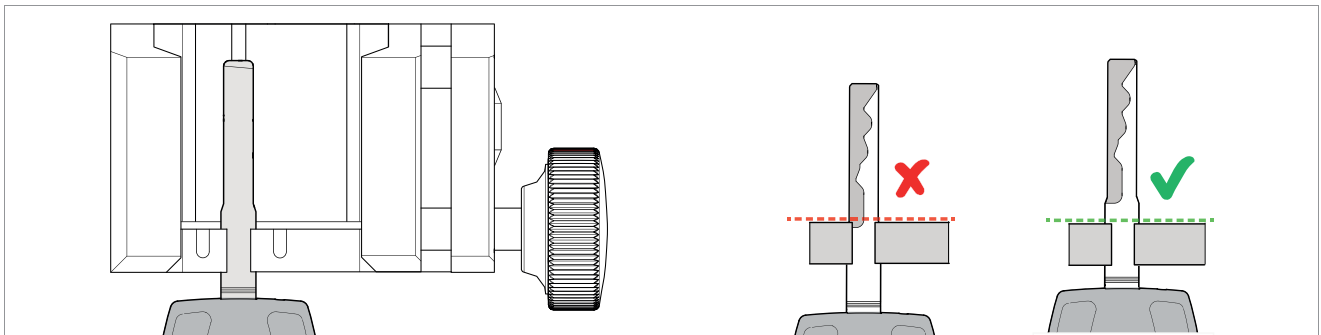

Fig. 38 - KEYS WITH TIP REFERENCE

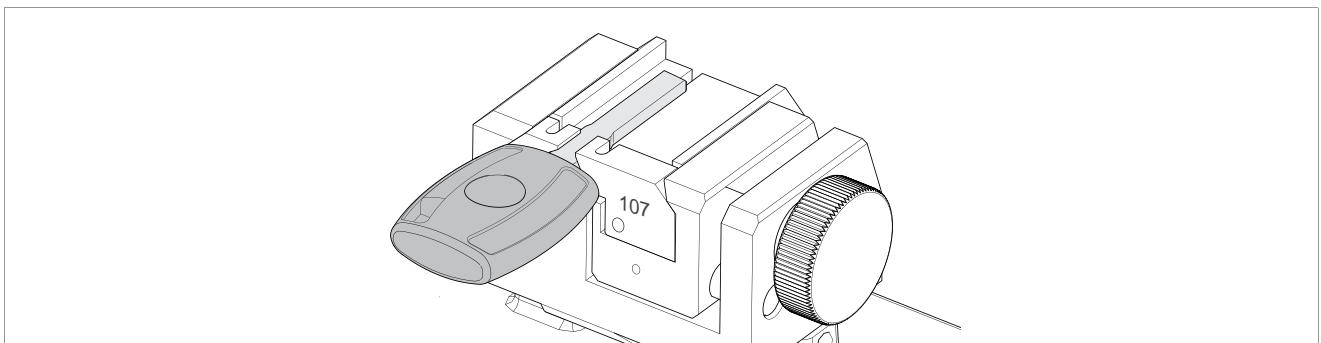

Fig. 39

5.3 REMOVING / FITTING CLAMPS 01VA AND 01RA

- 1) Raise the safety shield.
- 2) Loosen the grub screw (P2) and remove the clamp by pulling it towards the operator.
- 3) Carefully clean the clamp support seat.
- 4) Clean the clamp before fitting into the support.
- 5) Fit the clamp into the special dovetail and take up against the stop pin.
- 6) Tighten the grub screw (P2) to secure the clamp.

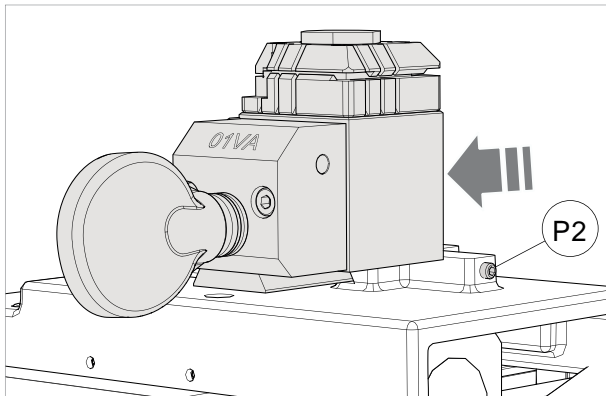

Fig. 40 - clamp 01VA

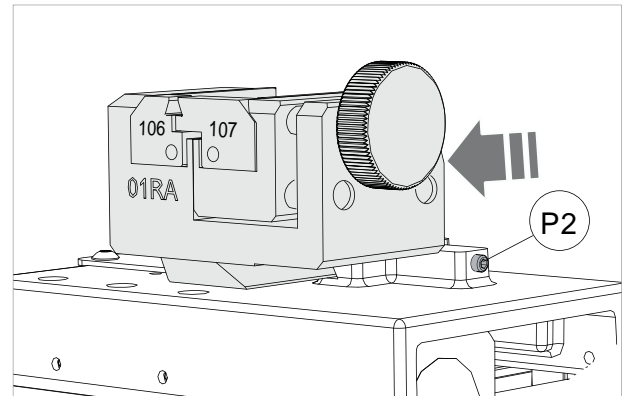

Fig. 41 - clamp 01RA

5.4 REMOVING/FITTING THE 106/107 JAWS ON CLAMP 01RA

- 1) Raise the safety shield.
- 2) Loosen the knob (P1) by a couple of turns (Fig. 42).
- 3) Use your fingers to pull the jaw to be removed out towards the operator (Fig. 43).
- 4) Carefully clean the seat of the jaw on the clamp.
- 5) Clean the jaw before fitting into the clamp.
- 6) Fit the jaw up against the stop pin.

NOTE: *there is only one way to fit the jaw into the clamp.*

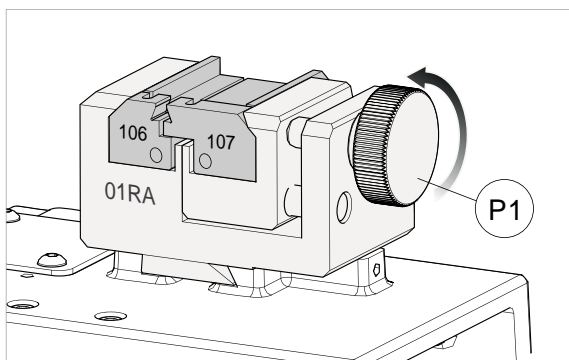

Fig. 42

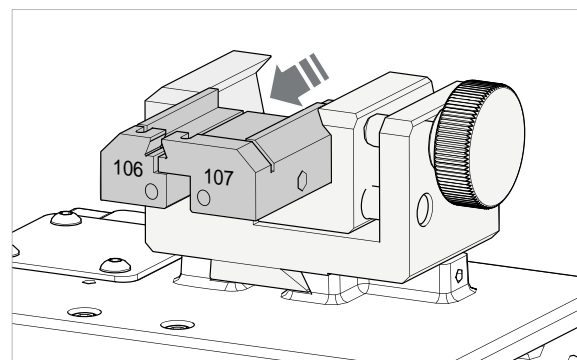

Fig. 43

5.4.1 FITTING OPTIONAL JAWS INTO THE 01RA CLAMP

- 1) Raise the safety shield.
- 2) Loosen and remove the knob (P1) (Fig. 44).
- 3) Use your fingers to pull the jaw to be removed out towards the operator (Fig. 45).
- 4) Carefully clean the seat of the jaw on the clamp.
- 5) Clean the new optional jaw before fitting it into the clamp.
- 6) Fit the jaw up against the stop pin (Fig. 46).
- 7) Insert the knob (P1) into its specific hole (Fig. 47).

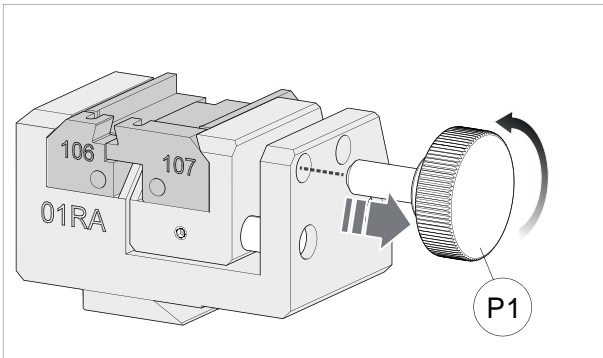

Fig. 44

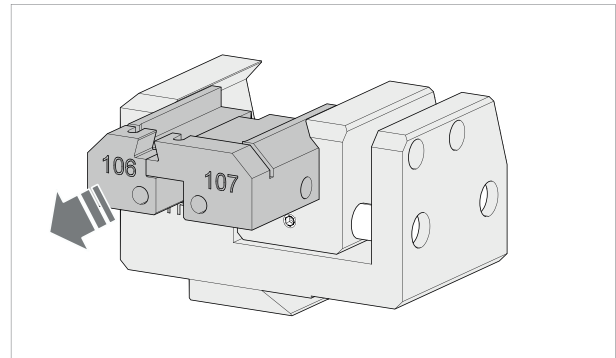

Fig. 45

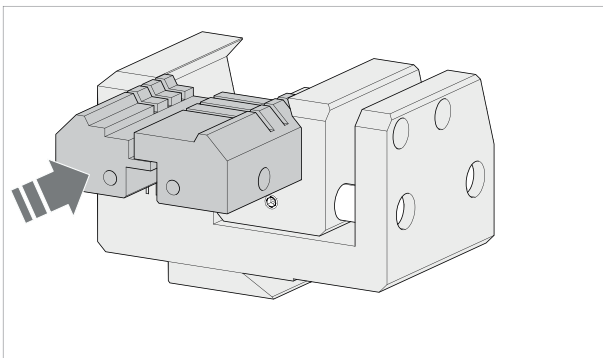

Fig. 46

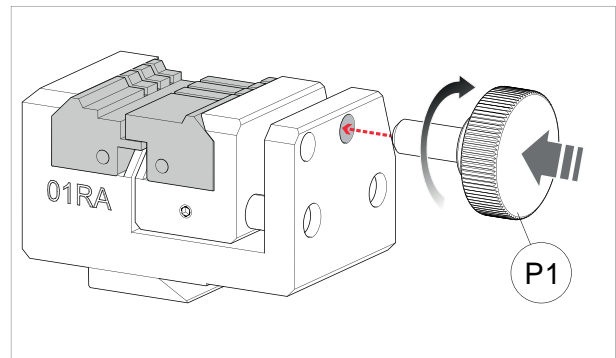

Fig. 47

5.5 USING TRACER 07T

The tracer 07T is used to read/decode flat keys and track keys.

This tracer may or may not be required according to the type of key to be decoded and the dimensions involved.

ATTENTION: Anodised aluminium keys, plastic keys or any other key without electrical conductivity CANNOT BE decoded and cut!

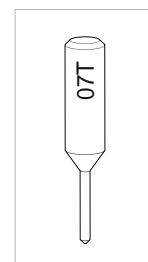

Fig. 48

- **ACTIVATING THE TRACER 07T (Fig. 49)**

- To use the tracer: move the lever (J1) to the left and lower the tracer.
- When the tracer is lowered, turn the lever knob clockwise.

- **EXCLUDING THE TRACER 07T (Fig. 50)**

- Turn the lever knob counterclockwise to unlock the tracer.
- Take the tracer to the idle position: raise the lever (J1) and move to the right.

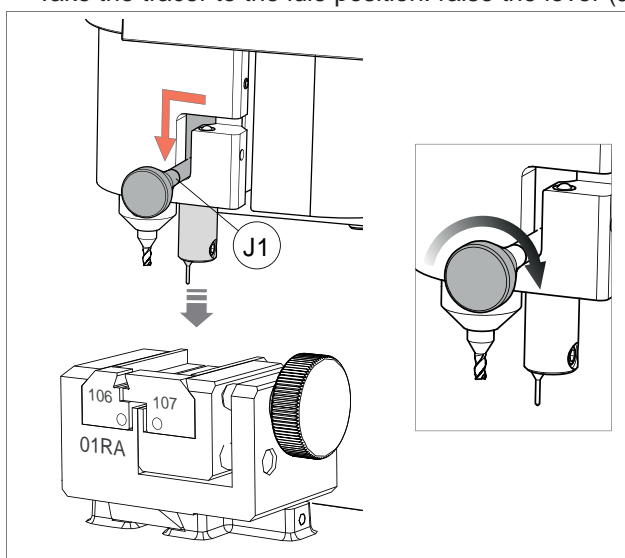

Fig. 49

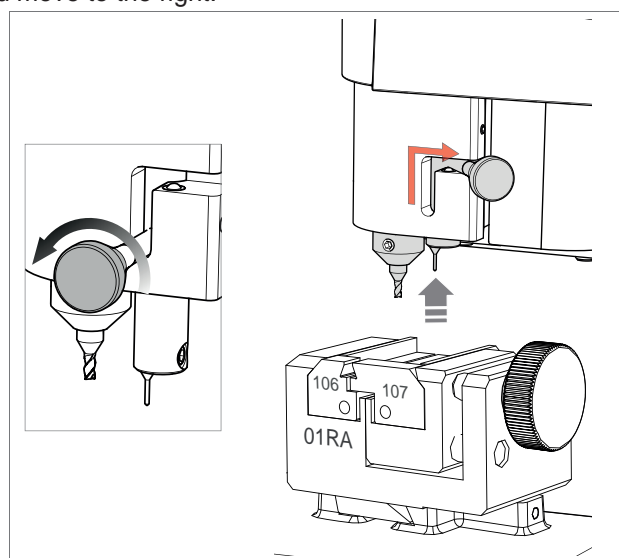

Fig. 50

5.6 TRACER 06T

Some applications may require the use of the 06T tracer. The 06T tracer (when required) should be placed into the cutter shaft (Fig. 52).

Note: fit the new tracer pushing all the way upwards.

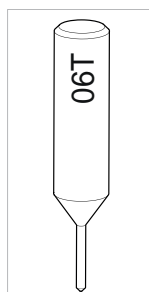

Fig. 51

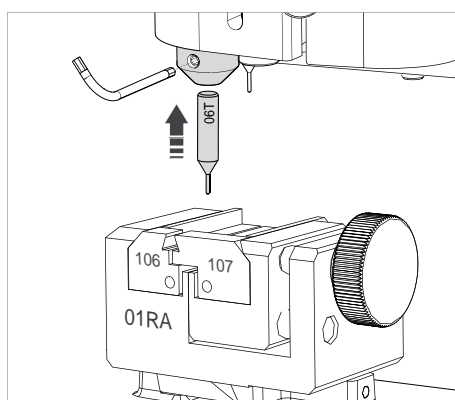

Fig. 52

NOTE: for cutting and/or decoding operations with the tracer point 06T, the tracer 07T must be in the idle position (Fig. 50). REPLACE THE 06T TRACER WITH THE REQUIRED CUTTER PRIOR TO ATTEMPTING TO CUT A KEY.

6 CLEANING

- **Keep the operational parts of the machine as clean as possible by brushing away the chippings in areas where they accumulate during cutting operations.**
- **Under no circumstances should compressed air be used to clear the work zone of chippings as this will blow them onto the moving parts.**
- **Never use oily products or thinners for cleaning painted surfaces, clamps, electrical or electronic connections.**
- **Make sure the key to be decoded is clean.**

7 MAINTENANCE

⚠ ATTENTION: for repairs or replacement of parts for maintenance, the 'CE' mark is guaranteed only if original spare parts provided by the manufacturer are used.

The FUTURA AUTO key-cutting machine does not need special maintenance, but it is good practice to check and if necessary replace parts subject to wear: cutter, tracer point, belt.

Replacement operations are simple and can be performed by the operator.

⚠ ATTENTION: DO NOT USE COMPRESSED AIR!

⚠ ATTENTION: to maintain machine efficiency we recommend using protective oil such as WD40 or similar to apply to the burnished mechanical parts. Make sure the oil does not come into contact with the electronic parts.

Before performing any type of maintenance (checks or replacements) read the warnings below:

- Do not perform any maintenance operations with the machine on.
- Always disconnect the power lead.
- Follow the instructions in the manual carefully.
- Use original spare parts (see provided spare parts sheet).

7.1 OPERATIONS

- Access to rear compartment
- Cylindrical cutter and/or tracer point replacement
- Tracer replacement
- Checking and replacing fuse
- Battery replacement
- Access to upper compartment
- Replacing the electrical contact brush
- Replacing the electrical contact brush set

7.2 ACCESS TO REAR COMPARTMENT

- 1) Turn off the key-cutting machine and disconnect the power lead.
- 2) Remove the tablet.
- 3) Loosen the 2 screws (E1) and the 2 screws (E2).
- 4) Rotate the cover towards the front of the machine.

ATTENTION to the tablet USB cable.

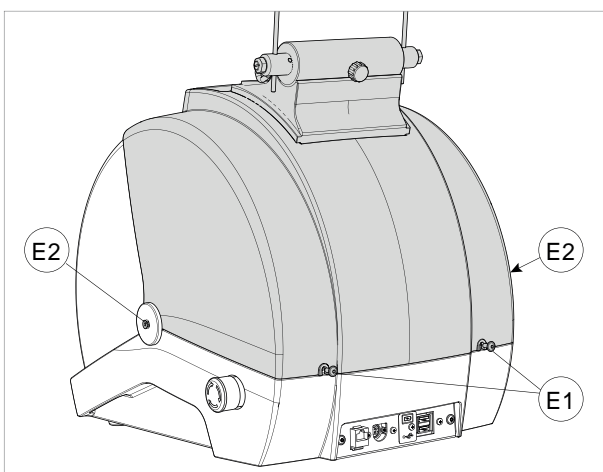

Fig. 53

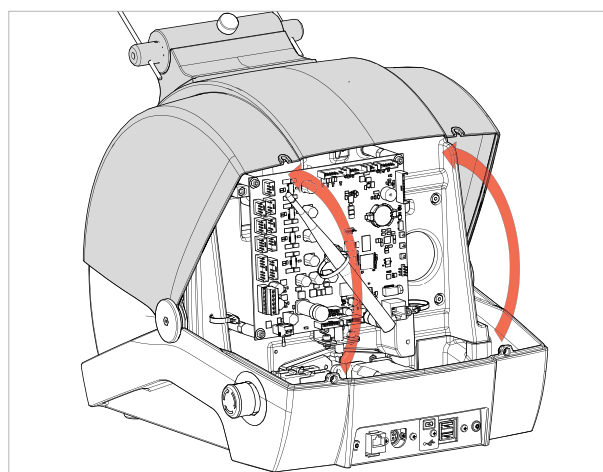

Fig. 54

7.3 CYLINDRICAL CUTTER AND/OR TRACER POINT REPLACEMENT

- 1) Raise the safety shield.
- 2) Rotate the cutter shaft (G1) by hand and take the grub screw (G2) to the front of the machine.
- 3) Use a hex key to loosen the grub screw (G2) and remove the tool.
- 4) Fit the new tool, pushing all the way upwards.
- 5) Tighten the grub screw (G2) to secure the tool.

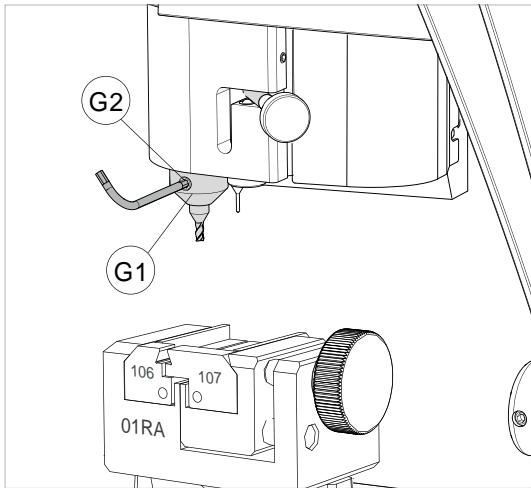

Fig. 55

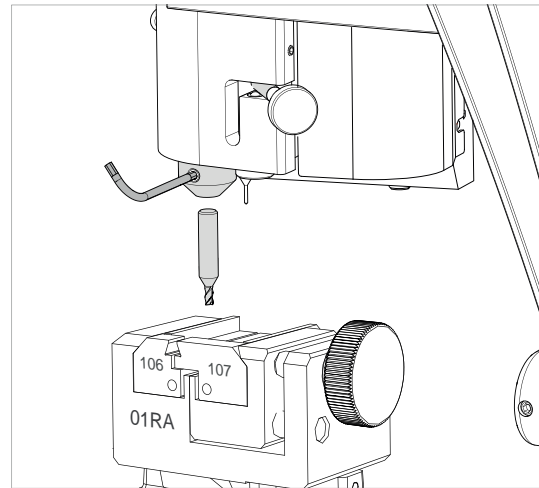

Fig. 56

NOTE: the machine is shipped with a steel rod installed in the cutter shaft to prevent the allen screw from backing out during transit. REMOVE THE ROD AND INSTALL THE PROPER CUTTER PRIOR TO ATTEMPTING TO CUT A KEY!

7.4 TRACER 07T REPLACEMENT

- 1) Raise the safety shield.
- 2) Move the lever (J1) to the left to lower the tracer.
- 3) Use a hex key to loosen the grub screw (J2) and remove the tracer.
- 4) Fit the new tracer, pushing all the way upwards.
- 5) Tighten the grub screw (J2) to secure the tracer.

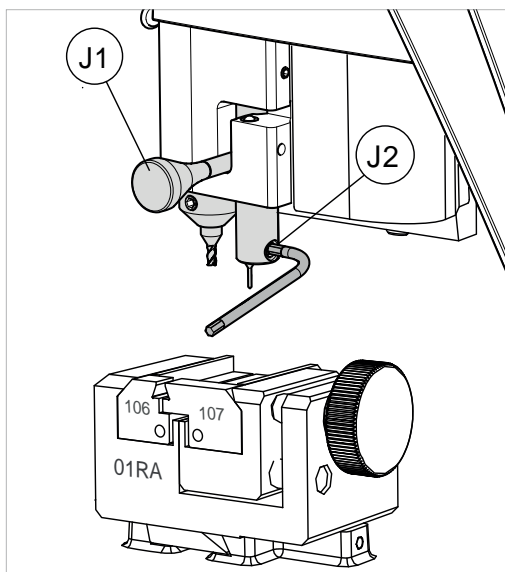

Fig. 57

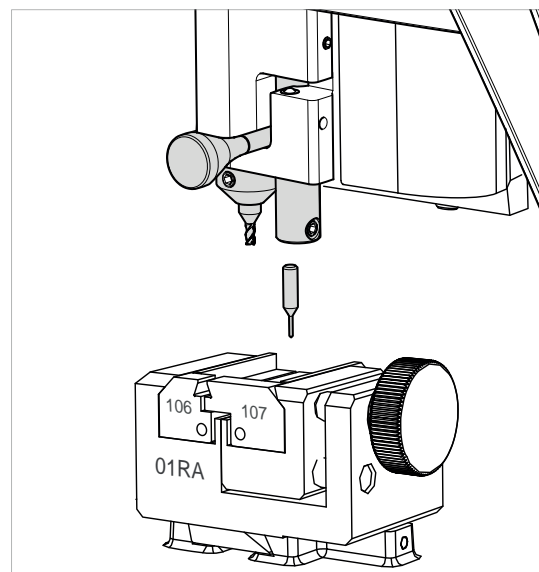

Fig. 58

7.5 CHECKING AND REPLACING FUSE

Fuses should be checked with a tester (ohmmeter, multimeter, etc.) as they may appear to be in good condition even when they are electrically faulty. Fuses must always be replaced with the same amperage and type (rapid or delayed), as indicated in this manual.

FUTURA AUTO has 1 fuse:

4 Amps delayed

Protects the cutters motors and their electronic controls (24 d.c.)

Follow the instructions below to check and, if necessary, replace:

- 1) Turn off the key-cutting machine and unplug.
- 1) Access the rear compartment (chap.7.2).
- 2) Remove the fuse from its seat (Fig. 59) and replace if necessary.

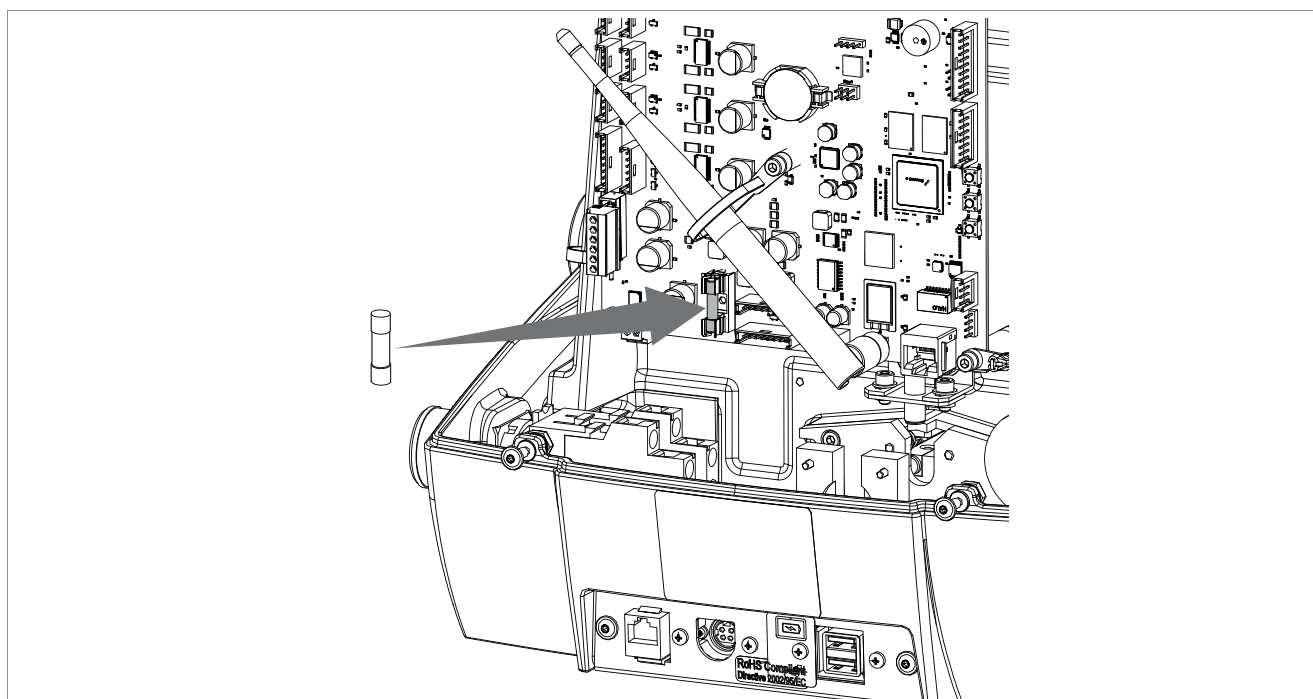

Fig. 59

7.6 BATTERY REPLACEMENT



ATTENTION: only specialised personnel can change the battery.

- 1) Turn the machine off and unplug it from its power supply cable.
- 2) Access the rear compartment (chap.7.2).
- 3) Use insulated screwdriver to remove the fl at battery.
- 4) Insert the new battery into its seat, paying attention to the poles.



ATTENTION: use the same type of lithium battery CR2032 3 Volt.

DANGER OF EXPLOSION IF THE BATTERY IS REPLACED WITH ONE OF THE WRONG TYPE.

- 5) Follow the instructions in Chap. 8 DISPOSAL to dispose of spent batteries.

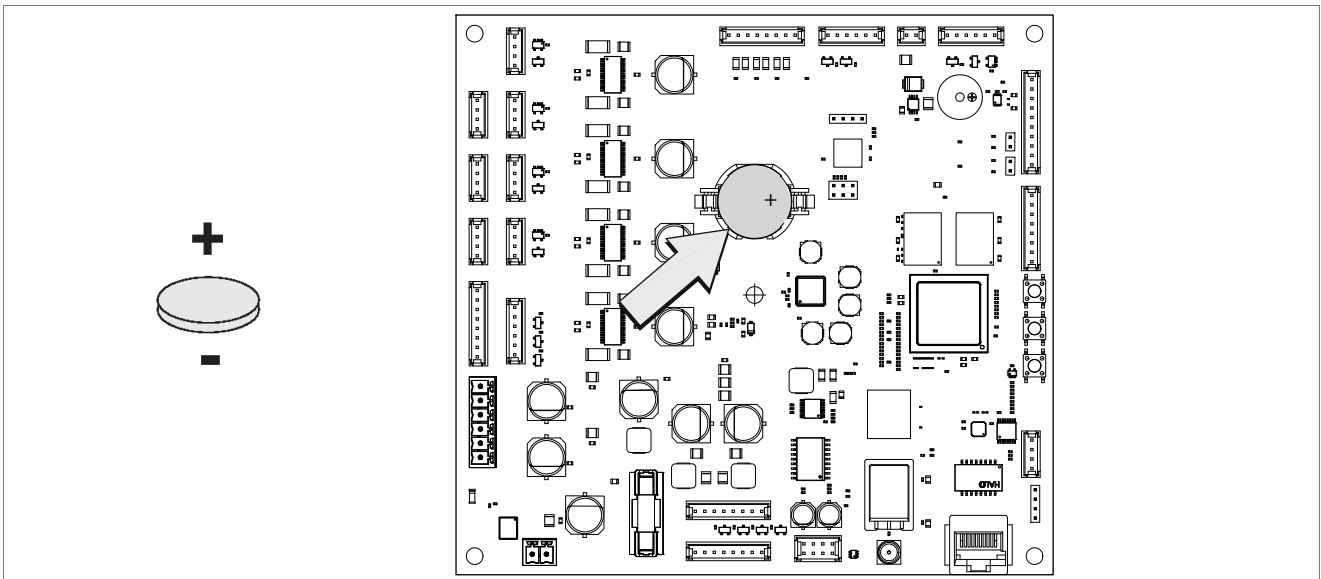

Fig. 60

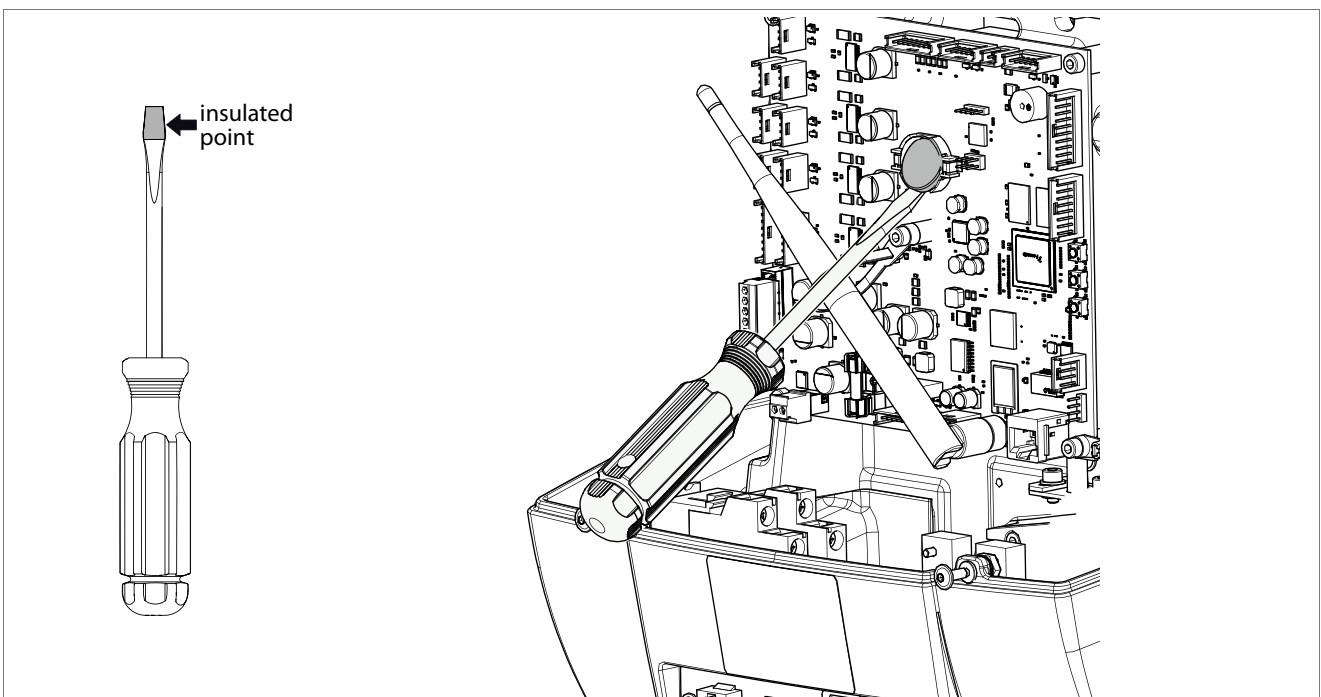

Fig. 61

7.7 ACCESS TO THE UPPER COMPARTMENT

- 1) Turn the machine off and unplug it from its power supply cable.
- 2) Remove the tablet and its holder.
- 3) Loosen the 2 rear screws (E1).
- 4) Loosen the 2 side screws (E2) and remove the 2 washers (E3).
- 5) Remove the top cover (E).
- 6) Remove the protective shield (C). Take care not to lose the 4 curved spring washers (T).
- 7) Loosen the grub screw (H1) and move the pawl (H2) outwards (Fig. 64) so that part of the gasket (H) can slide out.
- 8) Loosen the 2 screws (K1) and move the belt cover (K).

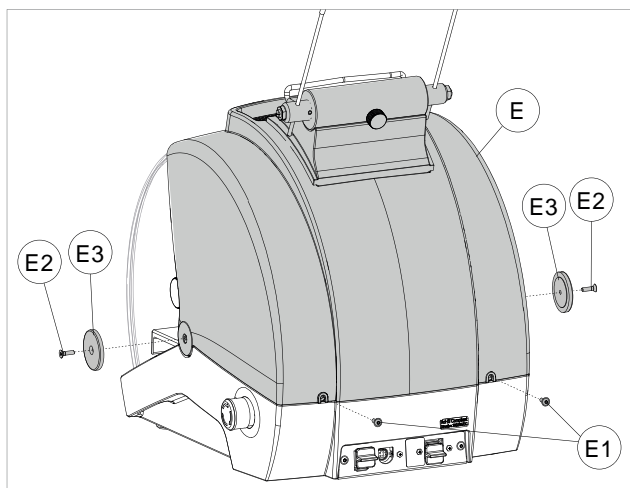

Fig. 62

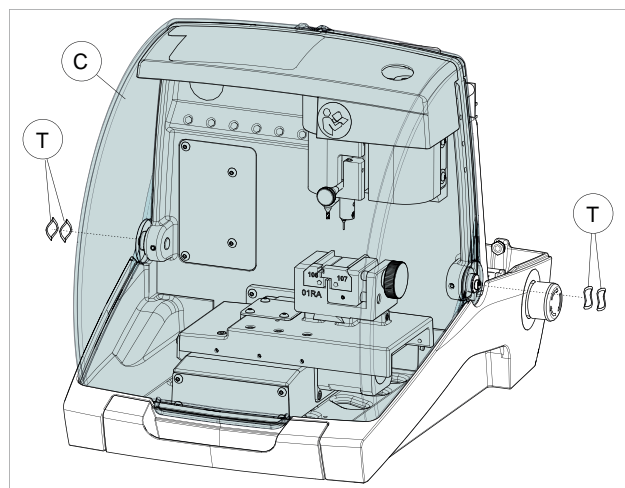

Fig. 63

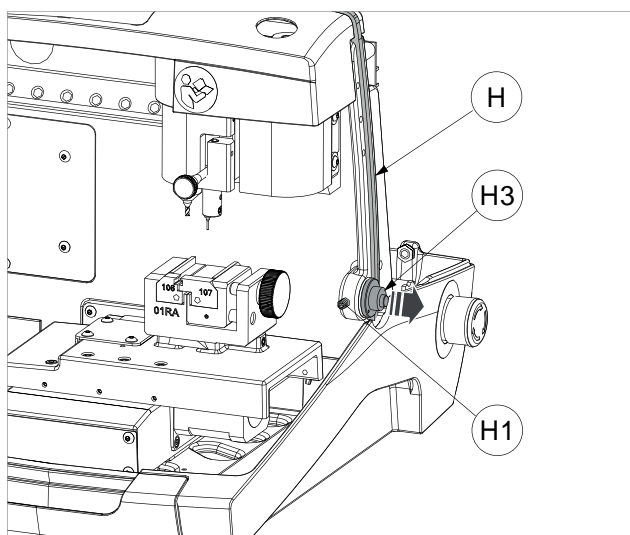

Fig. 64

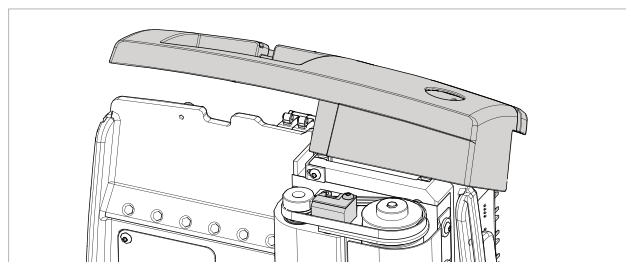
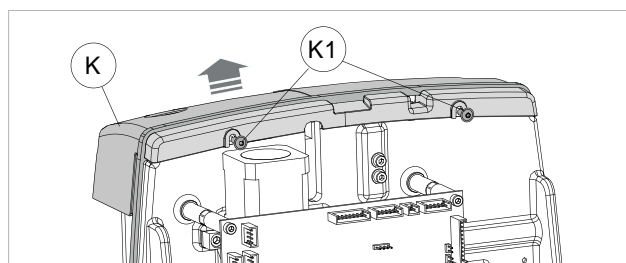

Fig. 65

7.8 REPLACING THE ELECTRICAL CONTACT BRUSH

- 1) Turn the machine off and unplug it from its power supply cable.
- 2) Access the upper compartment (cap.7.7).
- 3) Loosen the screw (V1) and remove the electrical contact plate (V) and brush (S).
- 4) Fit a new brush.
- 5) Replace the plate and tighten the screw (V1).

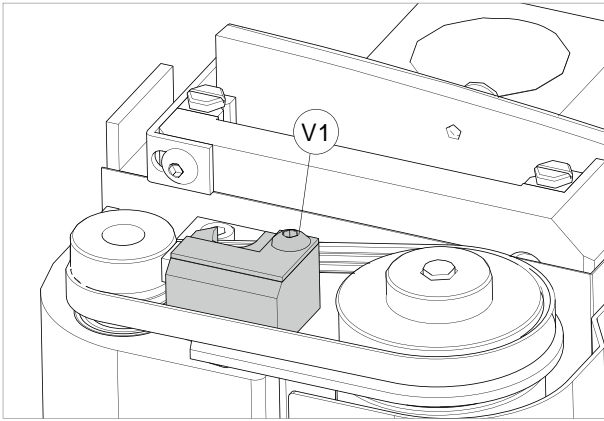

Fig. 66

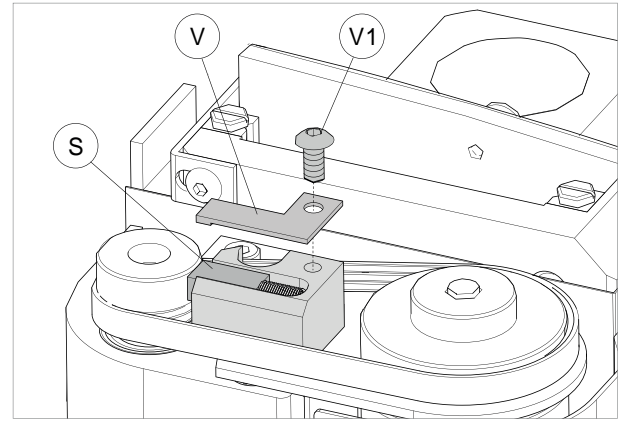

Fig. 67

7.9 REPLACING THE ELECTRICAL CONTACT BRUSH SET

- 1) Loosen the screw (S1) and remove the set.
- 2) Fit a new set and tighten the screw (S1).

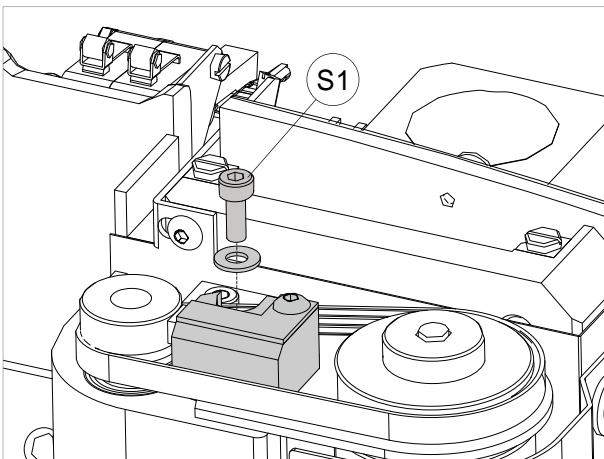

Fig. 68

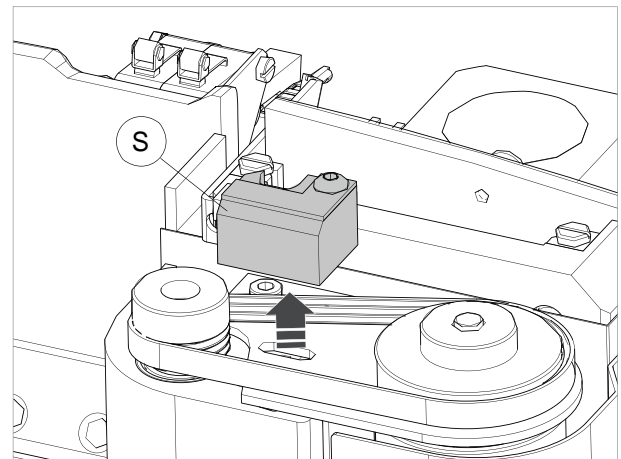

Fig. 69

8 DISPOSAL

For correct disposal please refer to current standards.

INFORMATION FOR USERS OF PROFESSIONAL EQUIPMENT



From “Actuation of Directive 2012/19/EU regarding Waste Electrical and Electronic Equipment (WEEE)”

The symbol of a crossed waste bin found on equipment or its packing indicates that at the end of the product’s useful life it must be collected separately from other waste so that it can be properly treated and recycled.

In particular, separate collection of this professional equipment when no longer in use is organised and managed:

- a) directly by the user when the equipment was placed on the market before 31 December 2010 and the user personally decides to eliminate it without replacing it with new equivalent equipment designed for the same use;
- b) by the manufacturer, that is to say the subject which was the first to introduce and market new equipment that replaces previous equipment, when the user decides to eliminate equipment placed on the market before 31 December 2010 at the end of its useful life and replace it with an equivalent product designed for the same use. In this latter case the user may ask the manufacturer to collect the existing equipment;
- c) by the manufacturer, that is to say the subject which was the first to introduce and market new equipment that replaces previous equipment, if it was placed on the market after 31 December 2010;

With reference to portable batteries/accumulators, when such products are no longer in use the user shall take them to suitable authorised waste treatment facilities.

Suitable separate collection for the purpose of forwarding discarded equipment and batteries/accumulators for recycling, treatment or disposal in an environmentally friendly way helps to avoid possible negative effects on the environment and human health and encourages re-use and/or recycling of the materials making up the equipment.

To remove batteries/accumulators, consult the manufacturer’s specific instructions: (see relevant chapter in the users’ manual)

The sanctions currently provided for by law shall apply to users who dispose of equipment, batteries and accumulators in unauthorised ways.

9 ASSISTANCE

Silca provides full assistance to purchasers of the key-cutting machine. To ensure complete safety for the operator, any job not specified in this manual should be carried out by the manufacturer or in the special Service Centres recommended by Silca.

At the end of the manual there is a list of manufacturers' and authorized Service Centre addresses.

9.1 HOW TO REQUEST SERVICE

The guarantee attached to the key-cutting machines ensures free repairs or replacements of faulty parts within 24 months of purchase. All other service calls must be arranged by the customer with Silca or with a Silca service center.

10 SOFTWARE OPERATING GUIDE

The FUTURA AUTO SOFTWARE OPERATING GUIDE is on the Tablet.
Go to the “Options” > “Info” menu and tap on the appropriate icon (Fig. 70).

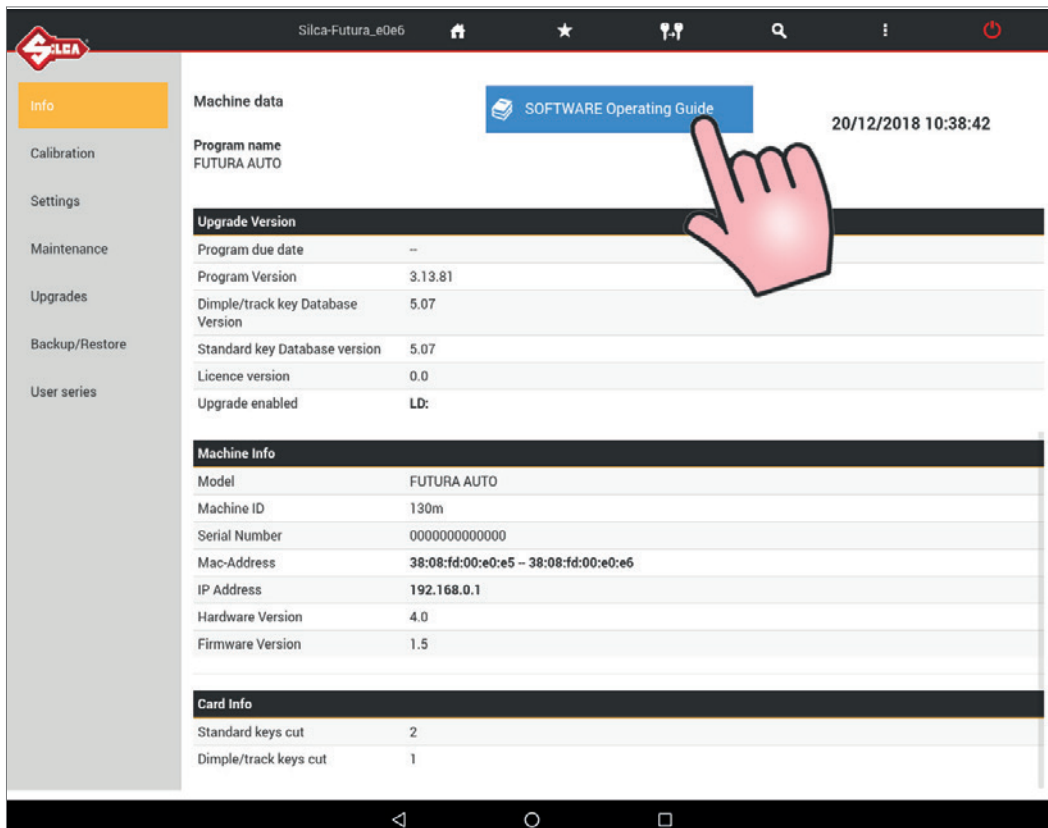
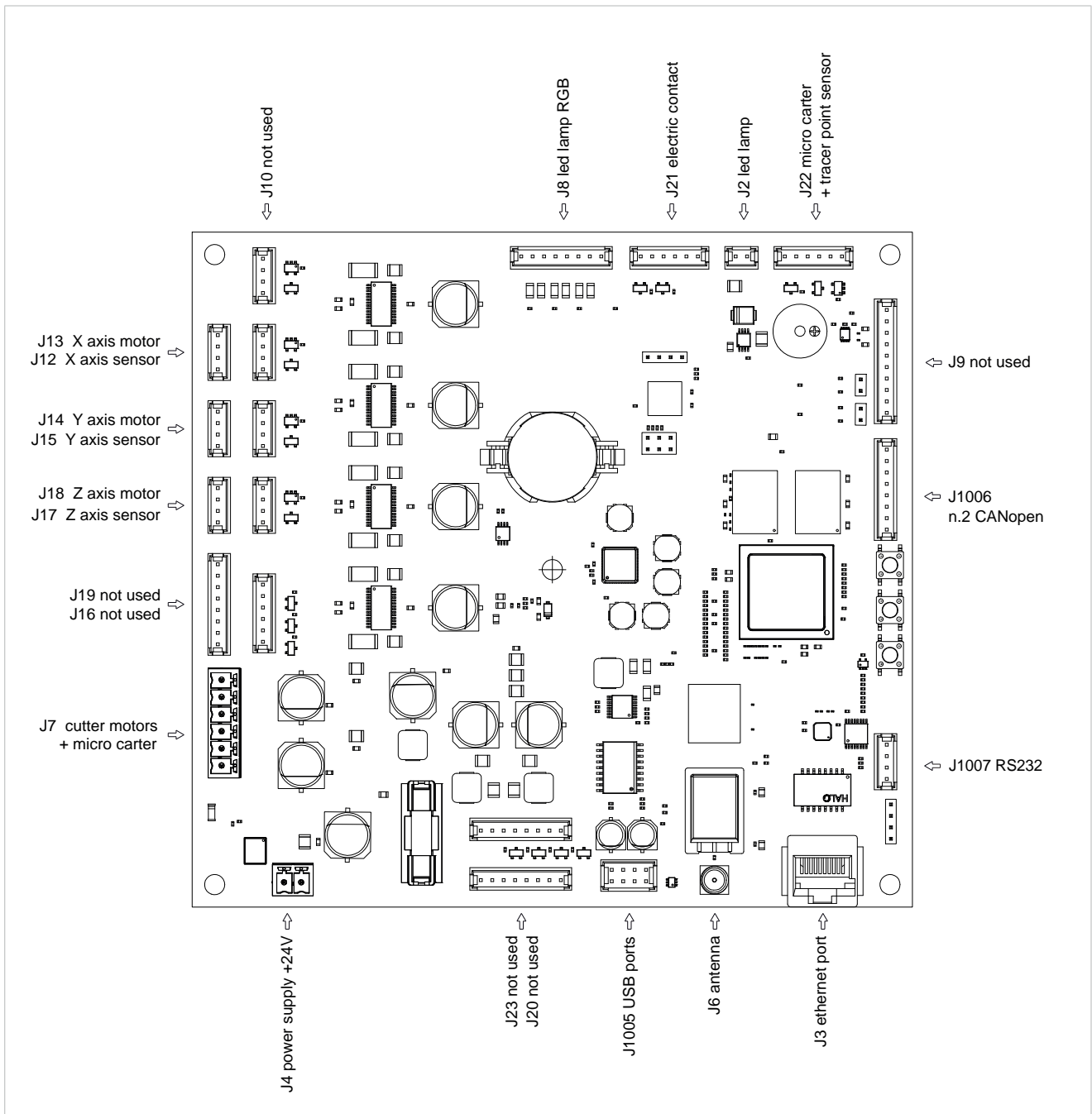
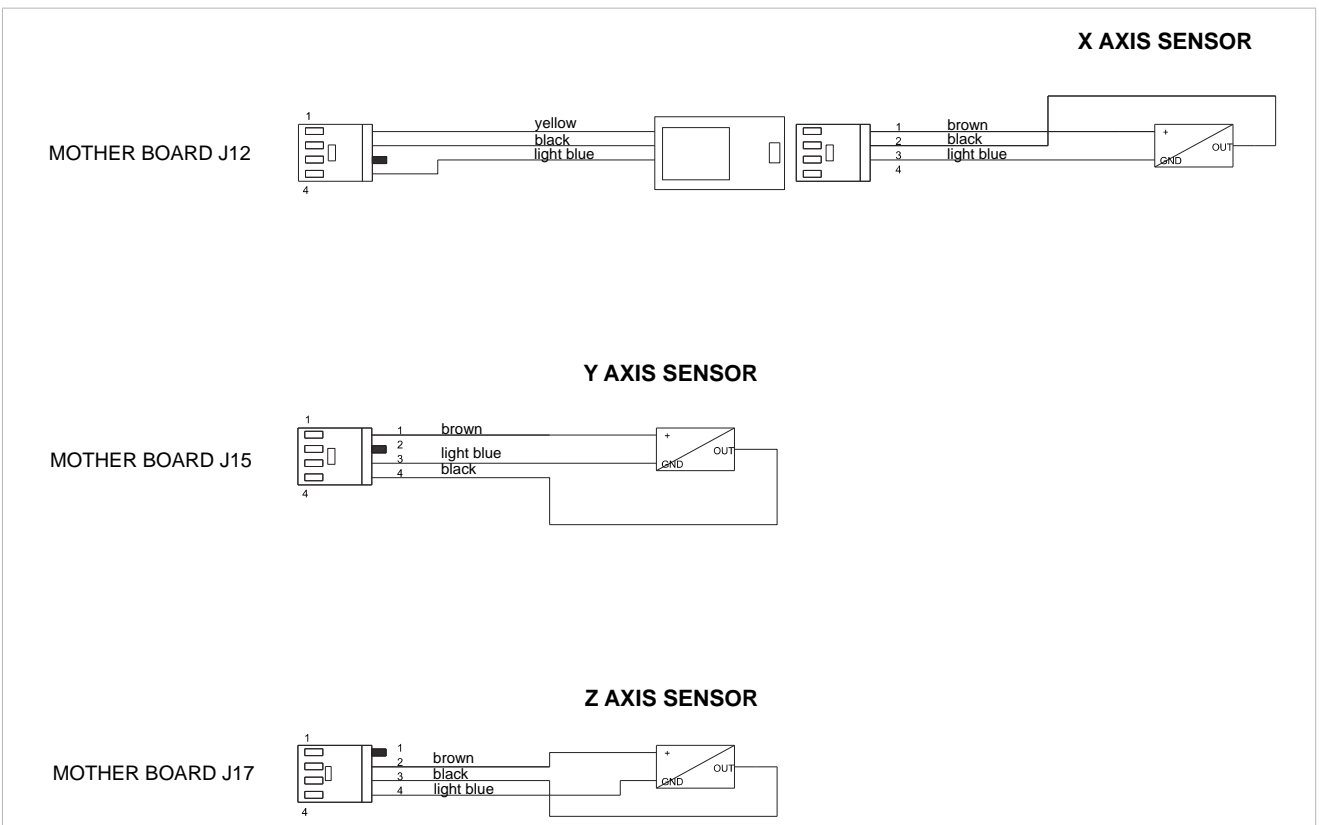
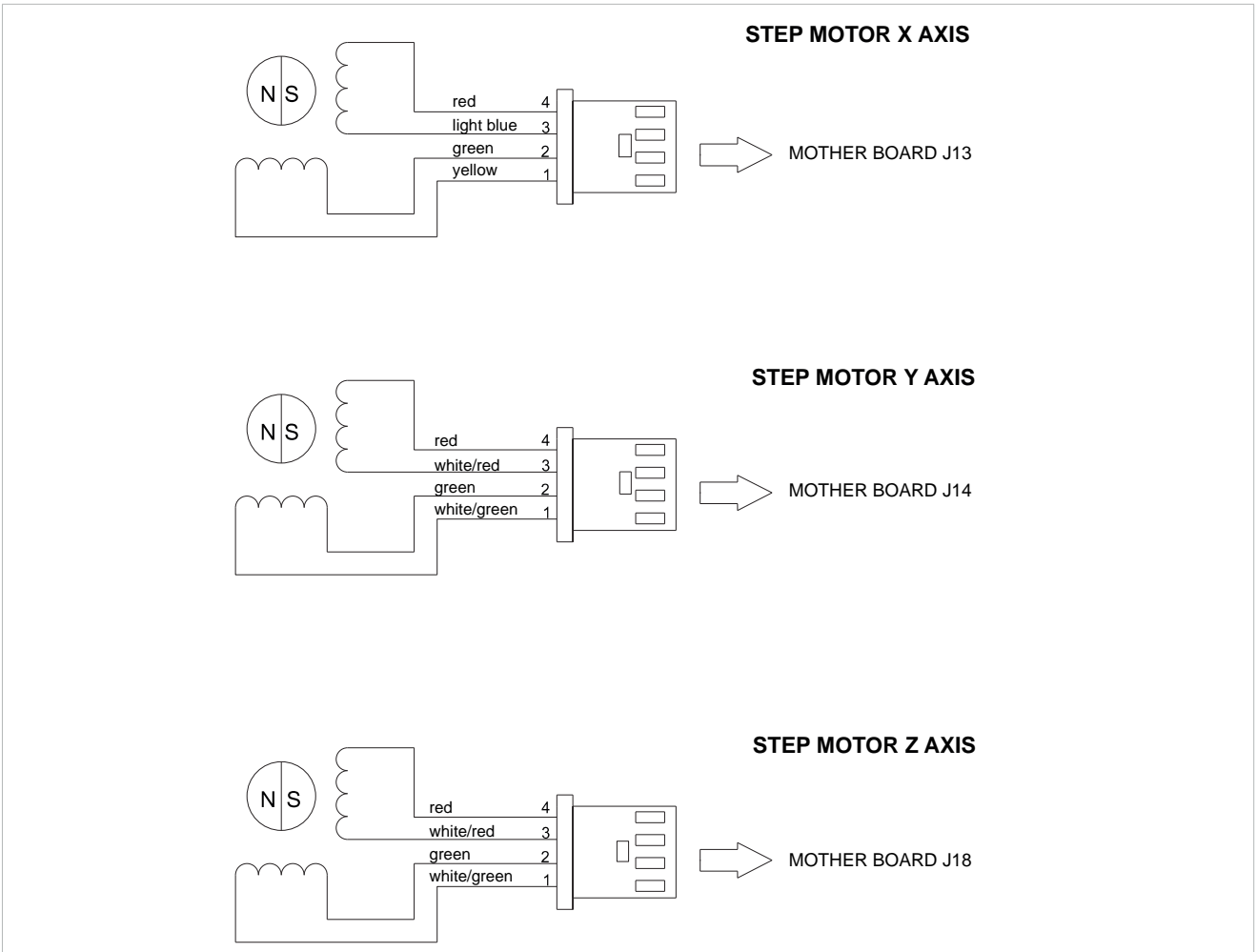
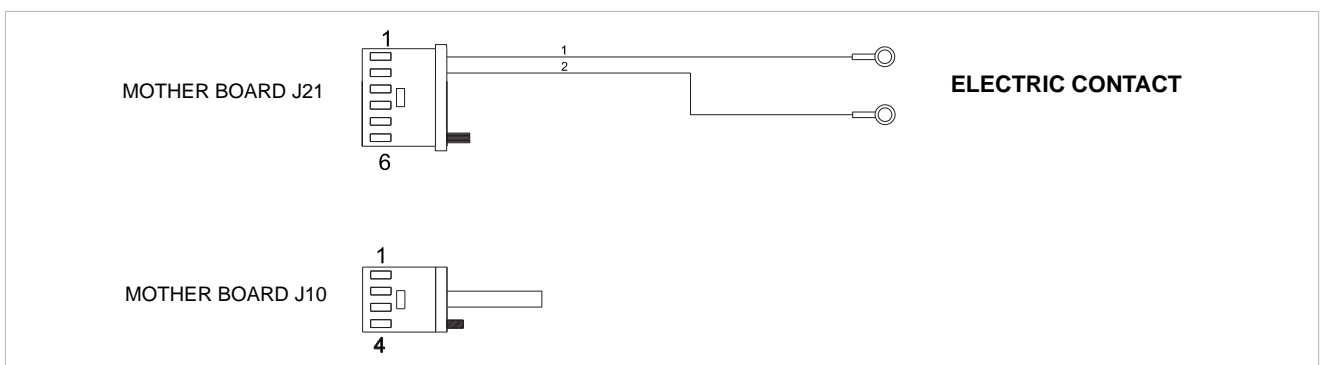
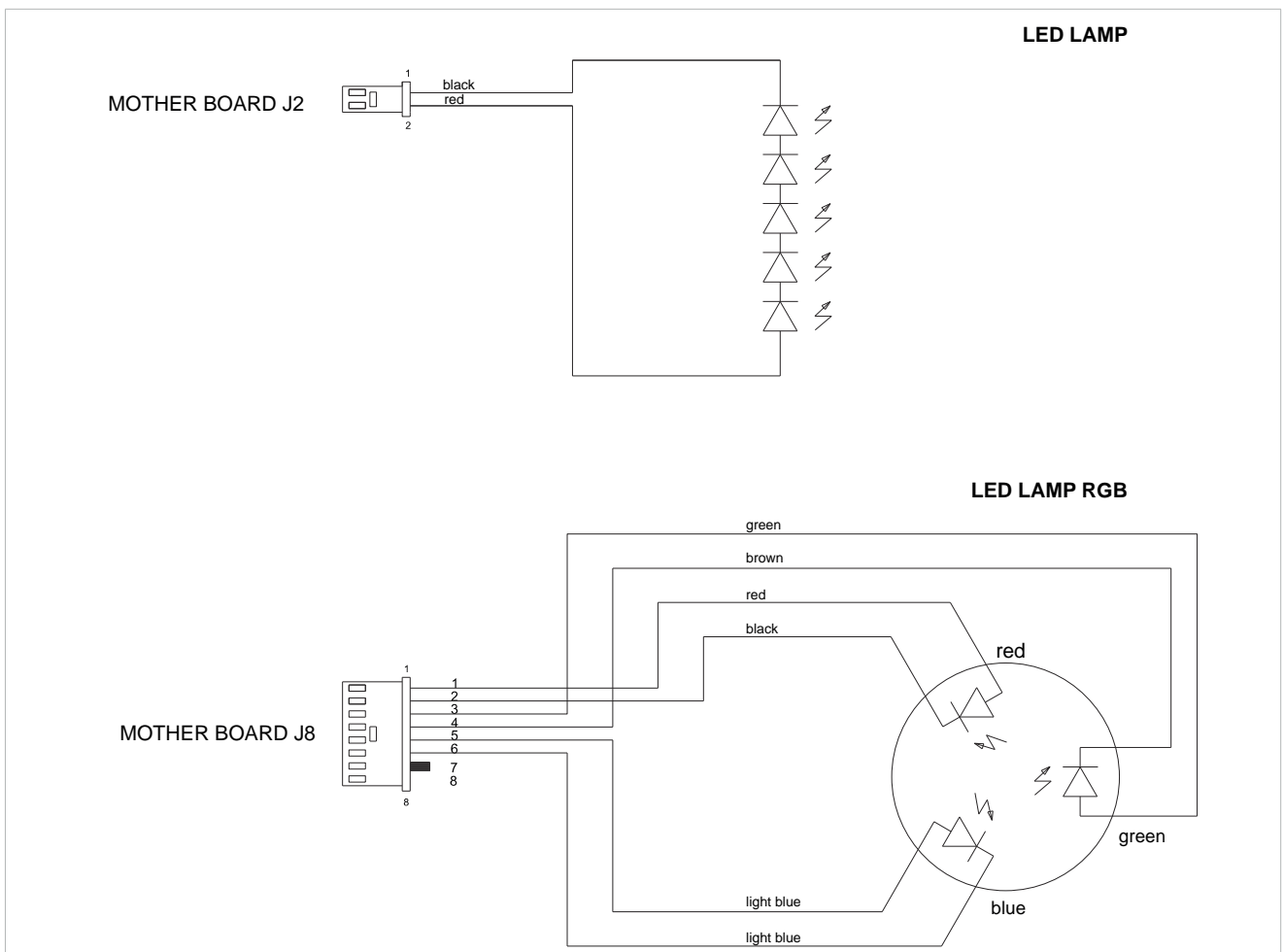
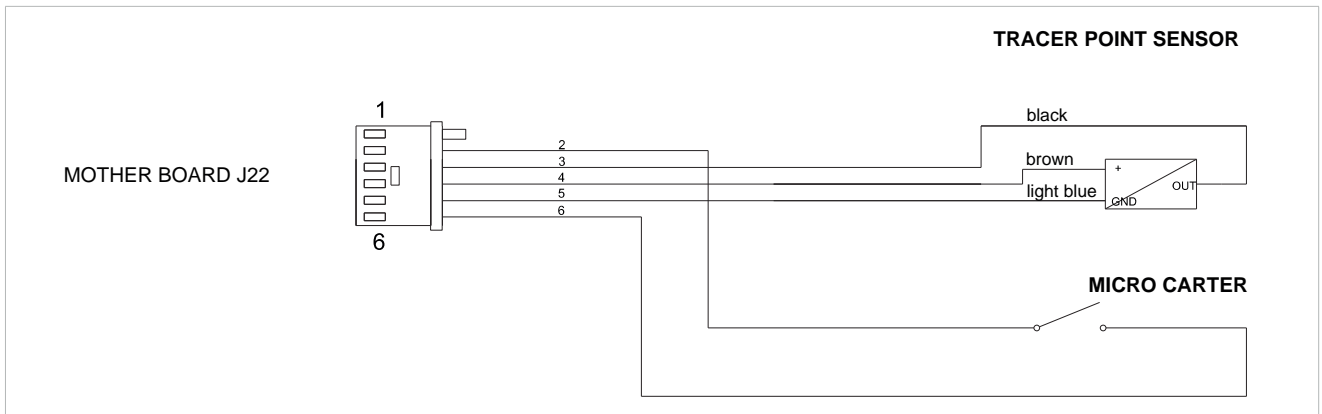

Fig. 70

11 ELECTRICAL DIAGRAMS







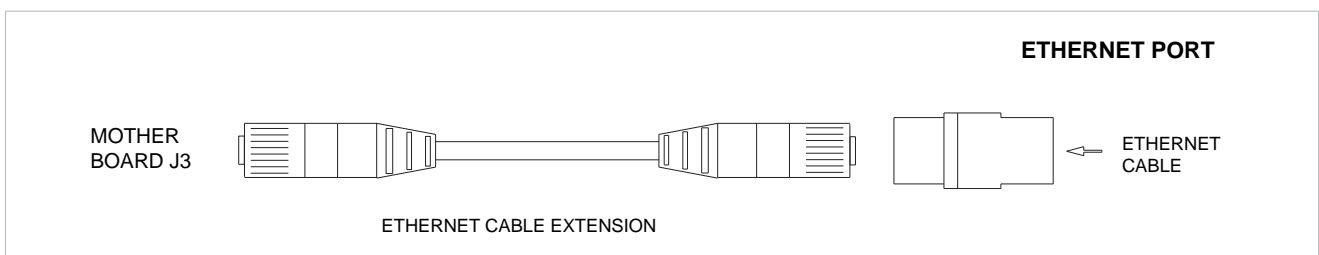
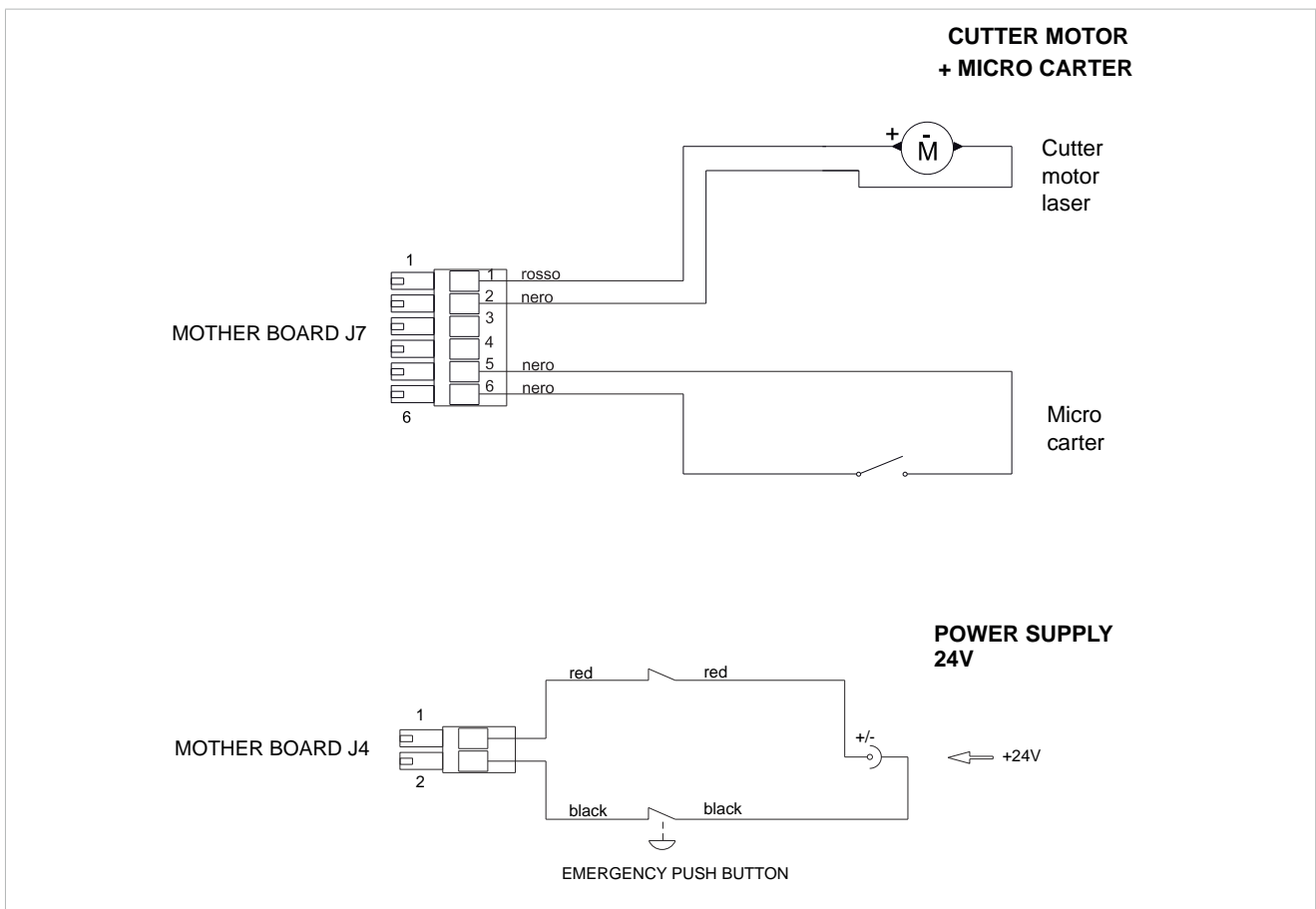
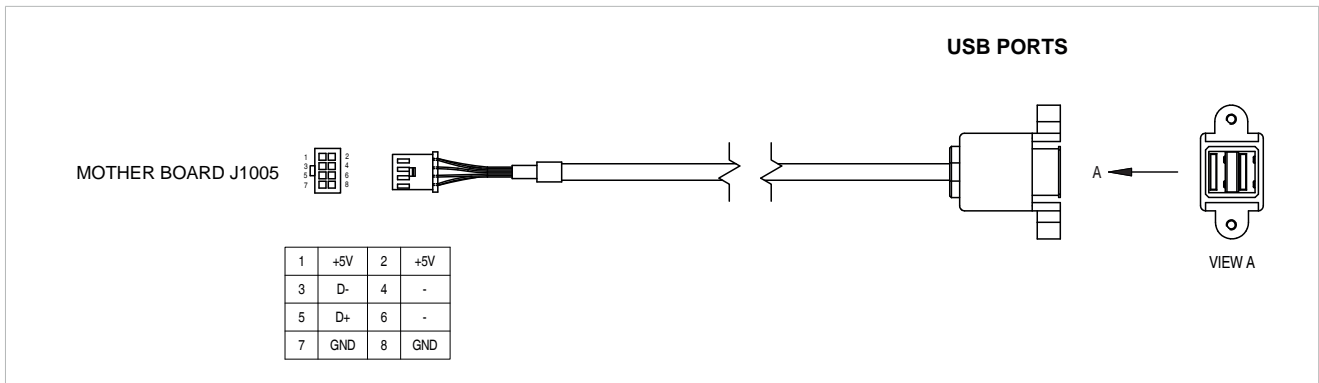

J2	Led lamp
J3	Ethernet port
J4	Power feeder +24V
J5	USB port
J6	Antenna
J7	Cutter motor + micro carter
J8	Led lamp RGB
J9	not used
J10	not used
J12	X axis sensor
J13	X axis motor
J14	Y axis motor
J15	Y axis sensor
J16	not used
J17	Z axis sensor
J18	Z axis motor
J19	not used
J20	not used
J21	Electric contact
J22	Micro carter + tracer point sensor
J23	not used
J1005	USB ports
J1006	n.2 CANopen
J1007	RS232