



SOFTWARE OPERATING MANUAL

FUTURA
FUTURA *PRO*



INDEX

| | | |
|---------|---|----|
| 1 | FUTURA MODELS - GENERAL INFORMATION | 5 |
| • | PROGRAM START | 6 |
| • | CHOICE OF KEYBOARD | 8 |
| • | CHANGE PROGRAM LANGUAGE | 8 |
| • | MEASURING UNITS..... | 8 |
| • | DROP-DOWN MENU | 9 |
| 2 | SEARCHES | 10 |
| 2.1 | STANDARD keys | 10 |
| 2.2 | VEHICLE keys..... | 10 |
| 2.3 | DIMPLE / TRACK keys | 10 |
| 2.4 | FULL KEY SEARCHING | 10 |
| 2.5 | TRASPONDER GUIDE | 10 |
| 2.6 | DATA CARD/SERIE info..... | 14 |
| 2.7 | Using a CUTTING DATA CARD | 16 |
| 2.8 | CUTTING STANDARD flat keys (cylinder and vehicle)..... | 24 |
| 2.9 | Cutting DIMPLE/TRACK/TUBULAR keys and CUTTING SPEED | 25 |
| 3 | COPY BY ORIGINAL..... | 26 |
| 4 | FAVORITE'S | 28 |
| 5 | QUEUE OF JOBS..... | 29 |
| 5.1 | “STANDARD” QUEUE OF JOBS | 29 |
| 5.2 | “OEM” QUEUE OF JOBS (only with OEM CLIENT function enabled)..... | 30 |
| 5.2.1 | OEM CLIENT function activation | 30 |
| 6 | ENGRAVING..... | 32 |
| 7 | OPTIONS..... | 42 |
| 7.1 | INFO | 42 |
| 7.2 | CALIBRATION..... | 43 |
| 7.2.1 | STANDARD key clamp calibration | 43 |
| 7.2.2 | DIMPLE/TRACK keys clamp calibration | 45 |
| 7.2.3 | MOBILE TRACER 01T calibration | 46 |
| 7.2.4 | STANDARD key Adapter calibration | 47 |
| 7.2.5 | DIMPLE/TRACK keys Adapters calibration..... | 47 |
| 7.3 | SETTINGS | 48 |
| 7.3.1 | Zero-point Calibration (STANDARD key) | 48 |
| 7.3.2 | Zero-point Calibration (DIMPLE/TRACK key) | 50 |
| 7.3.3 | Options..... | 52 |
| 7.3.3.a | General..... | 52 |
| 7.3.3.b | Preferences STANDARD key | 54 |
| 7.3.3.c | Preferences DIMPLE/TRACK key | 55 |
| 7.3.4 | USE | 56 |
| 7.3.4.a | ACCESS POINT mode (Wi-Fi connection between machine and Tablet) | 56 |
| 7.3.4.b | ETHERNET with connection to LAN and router | 58 |
| 7.3.4.c | TETHERING USB mode..... | 59 |
| 7.3.4.d | LOCAL NETWORK mode..... | 61 |
| 7.4 | MACHINE MAINTENANCE..... | 65 |
| 8 | MACHINE UPDATE and REGISTRATION | 69 |
| 8.1 | MACHINE REGISTRATION | 69 |
| 8.2 | MACHINE SOFTWARE UPDATE | 75 |
| 8.2.1 | Update by TABLET..... | 75 |
| 8.2.2 | Update by USB PEN | 77 |
| 8.2.3 | Update with LOCAL NETWORK connected to the internet..... | 78 |
| 8.2.4 | Update with SRS Program (Silca Remote Service) | 80 |
| 8.3 | APP UPDATE (Silca.apk and SilcaKeyboard.apk)..... | 82 |
| 9 | BACKUP / RECOVERY | 85 |
| 10 | USER SERIES..... | 86 |
| 11 | CODE MAKER..... | 90 |
| 12 | TRASPONDER GUIDE..... | 91 |

| | | |
|------|--|-----|
| 13 | "TOKEN" AND "UTP" (Unlimited Token Plan) | 93 |
| 13.1 | TOKEN APPLICATION ON THE MACHINE | 95 |
| 13.2 | COPY BY ORIGINAL AND DATA CARD CUTTING FLOW (on Token version) | 95 |
| 14 | CHANGING TABLETS | 99 |
| 15 | FUTURA PROCEDURE TO CLEAR CACHE | 102 |

1 FUTURA MODELS - GENERAL INFORMATION

- **Futura PRO / Futura**

A machine for cutting/decoding keys with standard, laser and dimple cuts and cutting by "Copy by original" of cylinder and automobile keys with standard cuts.

- **Futura PRO NA / Futura NA**

A machine (for the North American market) for cutting/decoding keys with standard, laser and dimple cuts and cutting by "Copy by original" of cylinder and automobile keys with standard cuts.

- **Futura PRO JAPAN / Futura JAPAN**

A cutting machine (for the Japanese market) for cutting/decoding keys with standard, laser and dimple cuts and cutting by "Copy by original" of cylinder and automobile keys with standard cuts.

- **Futura PRO AUTOMOTIVE / Futura AUTOMOTIVE**

Cutting machine for cutting/decoding vehicle keys (cars, motor bikes, trucks, bicycles and relative accessories, etc.) with standard and laser cuts. Cutting by "Copy by original" of vehicle keys with standard cuts.

- **Futura PRO TOKEN / Futura TOKEN (Ch.13)**

"Pay per use" key-cutting machine run on tokens.

Note: please check with Silca whether the token option is available on the version you require.

- **FUTURA PRO ENGRAVING (Ch.6)**

Cutting machine for:

- cutting/decoding keys with the following types of cuts: standard, laser and dimple, or cut by 'Copy from original' for cylinder and vehicle keys with standard cuts.
- engraving on keys (head or neck) or medals, by the special accessories provided.

• PROGRAM START



To start the program tap the icon on the Tablet screen.

If the program does not start check the network settings/use (see Ch.7.3.4).

FUTURA PRO



1- Search

Menu used to select a category of Series Searches.

2 - Copy by Original

Menu used to make a copy of a key by means of a laser reader (standard edge cut keys only).

3 - Favourites

Menu used to access a series of searches previously set up as favourites.

4 - Queue of jobs

Menu used to run the job queue previously created by the search menu or optional OEM Client menu (optional - Ch.5.2).

5 - Options

Menu used to set up the machine.

6

The name of the machine model being used is shown.

7 - Upgrades

Menu used to update machine software.

8 - Info

Menu showing machine details.

9 - Engraving

Menu used to engrave keys (head or neck) and medals.

FUTURA

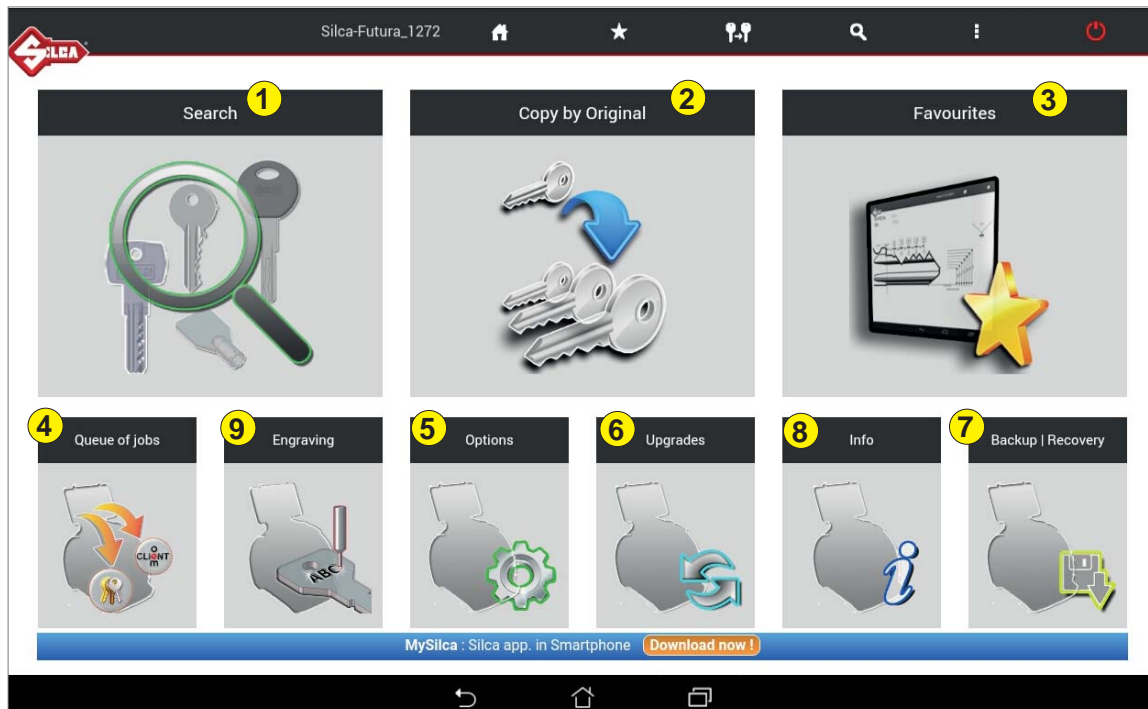

1- Search

Menu used to select a category of Series Searches.

2 - Copy by Original

Menu used to make a copy of a key by means of a laser reader (standard edge cut keys only).

3 - Favourites

Menu used to access a series of searches previously set up as favourites.

4 - Queue of jobs

Menu used to run the job queue previously created by the search menu or optional OEM Client menu (optional - Ch.5.2).

5 - Options

Menu used to set up the machine.

6 - Upgrades

Menu used to update machine software.

7 - Backup | Recovery

Menu used to save machine data and restore them when necessary.





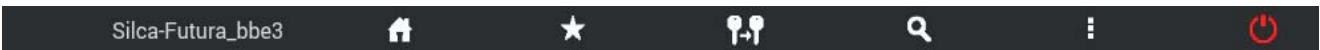

8 - Info

Menu showing machine details.

9 - Engraving

Menu used to engrave keys (head or neck) and medals.



- Silca-Futura_bbe3** **Machine ID:** shows the name of the FUTURA PRO machine.
-  **Initial menu:** tap the symbol to go back to the initial menu.
-  **Favourites:** tap the symbol to view the data cards/series saved in the favorites menu.
-  **Copy by Original:** tap the symbol for direct access to the “Copy by Original” menu.
-  **Search menu:** tap the symbol for direct access to the “Search” menu.
-  **Information:** tap the symbol to view information about the FUTURA PRO machine
-  **Turn off machine:** tap the symbol to turn off the FUTURA PRO machine without affecting the software; wait until the green light goes out and then turn off the machine with the ON/Emergency push button.

• **CHOICE OF KEYBOARD**

When the FUTURA program is started you are required to choose the type of keyboard you will use for entering data.

SILCA Keyboard: smaller keyboard specially designed for the FUTURA program.

ASUS Keyboard: standard Android Tablet keyboard.



If you have chosen the Silca keyboard you can go back to Android by hitting the key on the Silca keyboard.



• **CHANGE PROGRAM LANGUAGE**

The default program language is English. To change language go to the **Options** menu (Ch.7), select **Settings** -> **Options** -> **General** -> **Language** and choose the language you require.

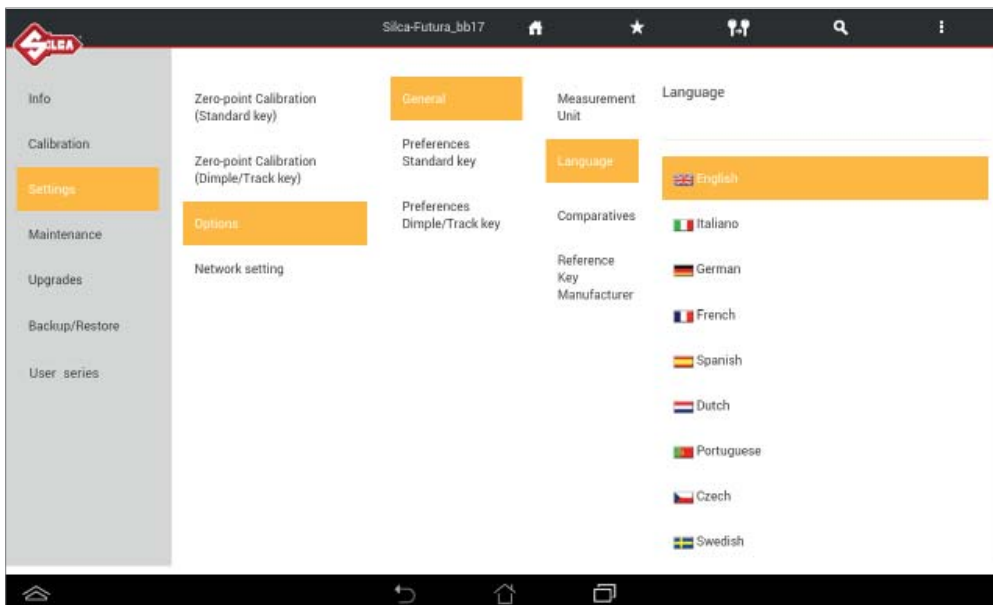

• **MEASURING UNITS**

All the values given in the program for the technical measurements of keys and clamps are expressed in hundredths of a millimetre (default) or thousandths of an inch, according to the measuring unit chosen from the “Options” menu.

• DROP-DOWN MENU

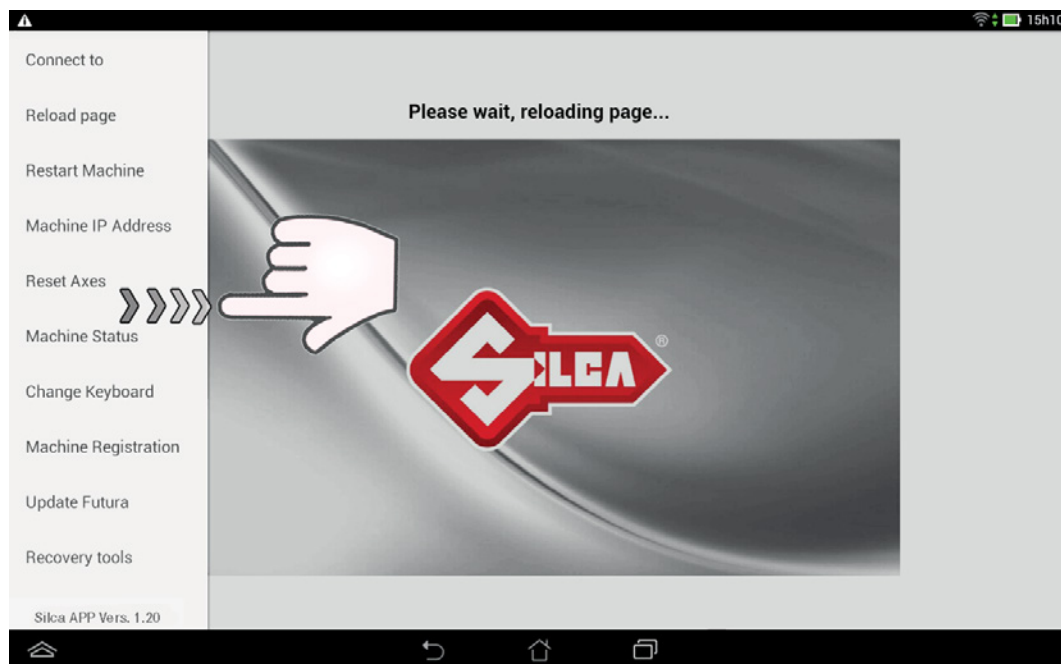

To view this menu on the Tablet scroll from left to right to open the list:

Connect to: used to find the Futura / Futura Pro machine, if there is a LAN connection or Wi-Fi ACCESS POINT.

Reload page: used to reload the page if it is not properly viewed/activated.

Restart Machine: used to restart the machine.

Machine IP address: used to enter the Futura / Futura Pro IP address manually (default is 192.168.0.1).

Reset Axes: used to clear the axes on the machine.

Machine Status: used to see connection status between the machine and Tablet.

Change Keyboard: used to select and set the type of keyboard to be used (Silca or ASUS keyboard)

Machine Registration: used to register the machine when the Tablet is connected to a Wi-Fi network with internet access.

Update FUTURA: used to download new updates for the machine:

- by tablet connected to a Wi-Fi network with access to the internet (Ch.8.2.1).
- by USB PEN DRIVE and PC with access to the internet (Ch.8.2.2).

Recovery tools: this function is protected by a password and is for the exclusive use of Silca personnel.

In addition, the Silca App version installed on the Tablet is shown below.

2 SEARCHES

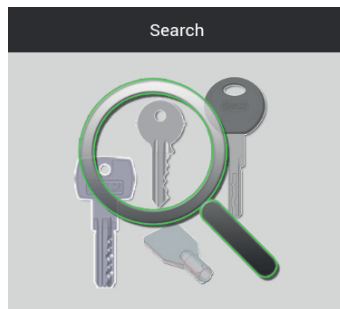

When the Searches menu is opened, the following window appears:

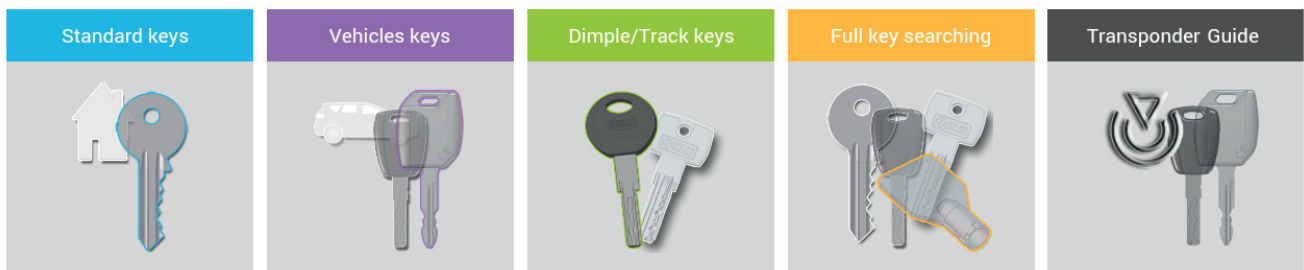

2.1 STANDARD keys

Menu used to make a search restricted to the category flat keys only (e.g.: CS207 - YA31 - UL050 ...). **(FUTURA Automotive / FUTURA PRO Automotive versions are excluded).**

2.2 VEHICLE keys

This menu is used to restrict a search to the category of standard edge cut and track vehicle keys only (e.g.: HU66P - GT15R - YM28T2 ...)

2.3 DIMPLE / TRACK keys

This menu is used to restrict a search to the dimple/track category of keys (e.g. CS48 - IE15 - AB48 ...). **(FUTURA Automotive / FUTURA PRO Automotive versions are excluded).**

2.4 FULL KEY SEARCHING

This menu is used to make extended searches not restricted to categories. **(FUTURA Automotive / FUTURA PRO Automotive versions are excluded).**

2.5 TRASPONDER GUIDE

The Transponder Guide contains all the transponder key copying solutions provided by Silca (Ch.11).

See example of STANDARD keys search flow:

When you enter the STANDARD keys category the following window appears for you to enter the search parameters.

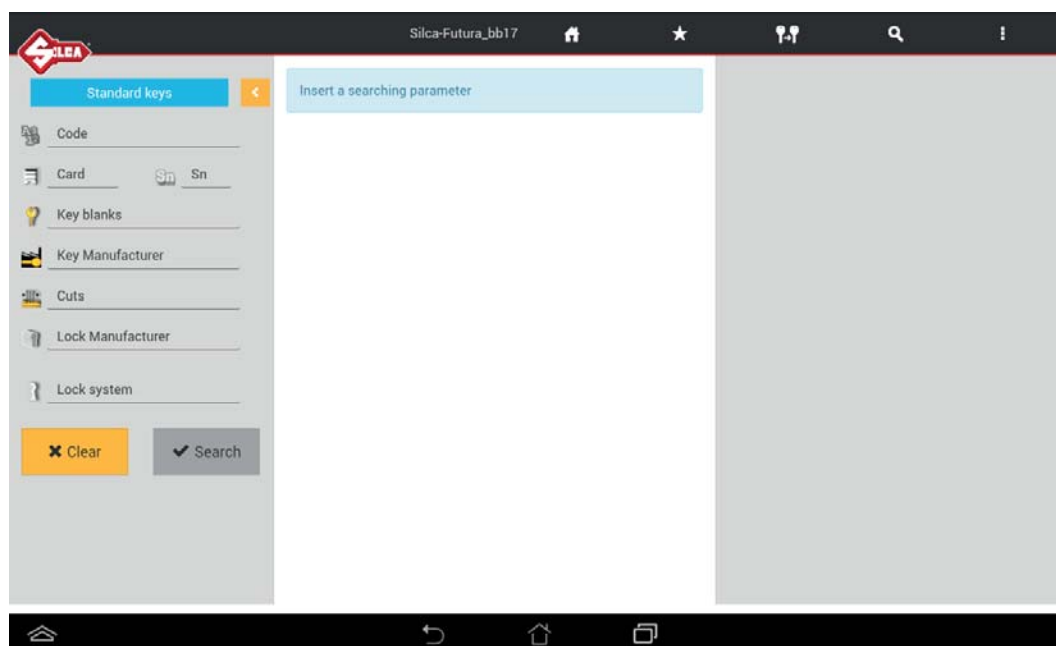
**SEARCH Parameters**

Code: enter the indirect key-cutting code.

Card / Sn: enter the card number or serial number assigned by Silca.

Key blanks: enter the Silca/Ilco key blank code or comparative.

Key manufacturer: enter name of key manufacturer.

Cuts: enter number of cuts for the key to be included in the search.

Lock Manufacturer: enter the brand of lock to be included in the search.

Lock system: enter the name of the lock system.

Press “**Clear**” to delete the entered fields.

After entering one or more parameters, tap the “**Search**” button to start the search. This operation will show the data relating to the lock systems found and information about the Silca/Ilco key blank, if applicable.

Tap  on the left-hand side of the page to re-open the Search Parameters window.

See example of VEHICLE keys search flow:

When you enter the VEHICLE keys category the following window appears for you to enter the search parameters.

Tap “VEHICLE MAKE”; a guided procedure appears to simplify your search.

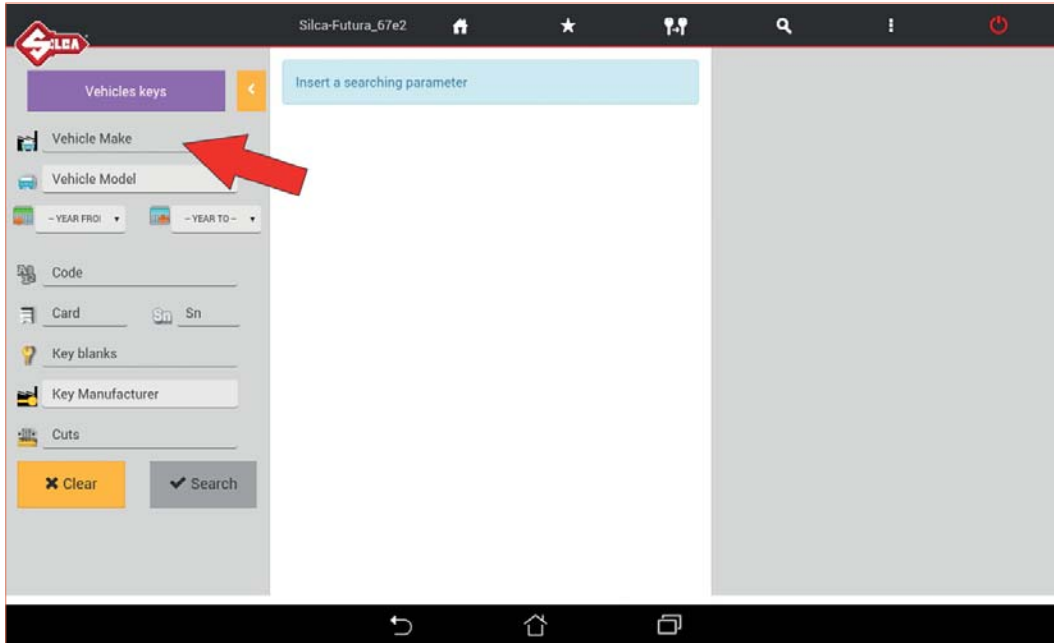

Enter the first letters of the MAKE and select the one you require.

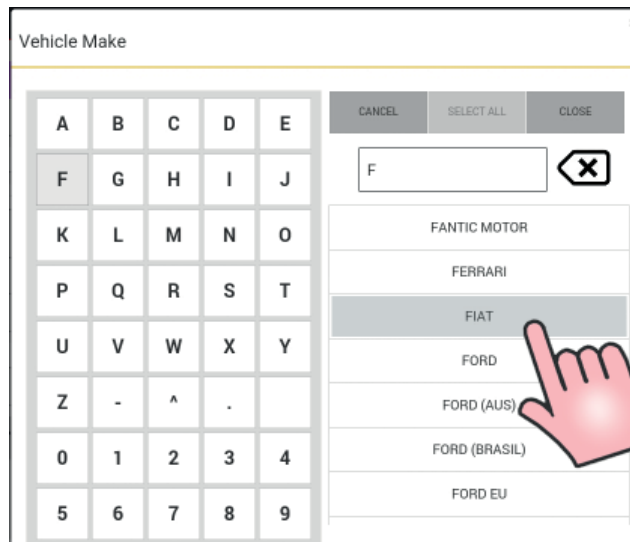

Enter the first letters of the VEHICLE MODEL and select the one you require.

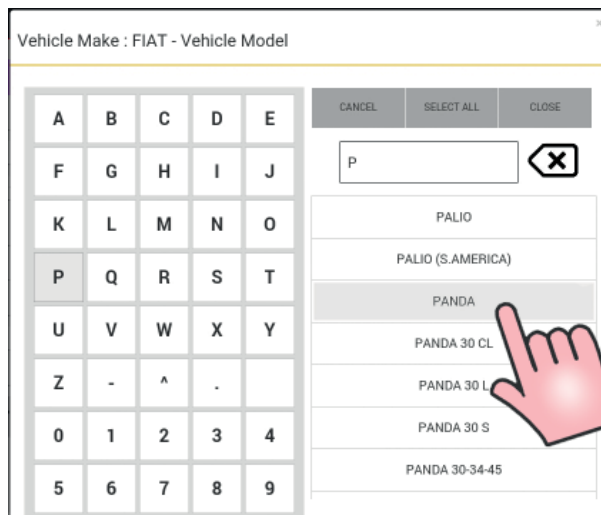

Select the YEAR.



Select the CARD key to access the cutting data card.

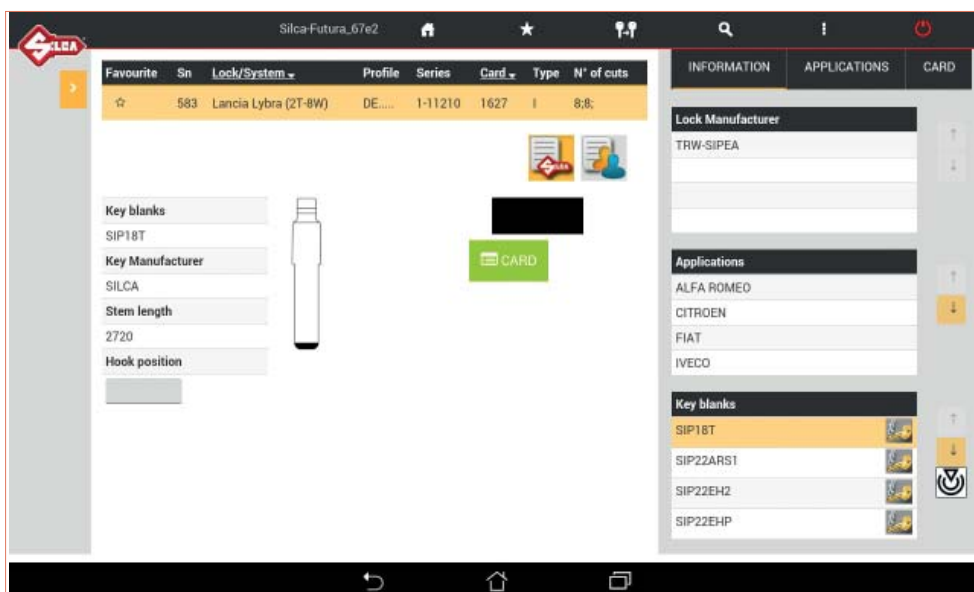

2.6 DATA CARD/SERIE info

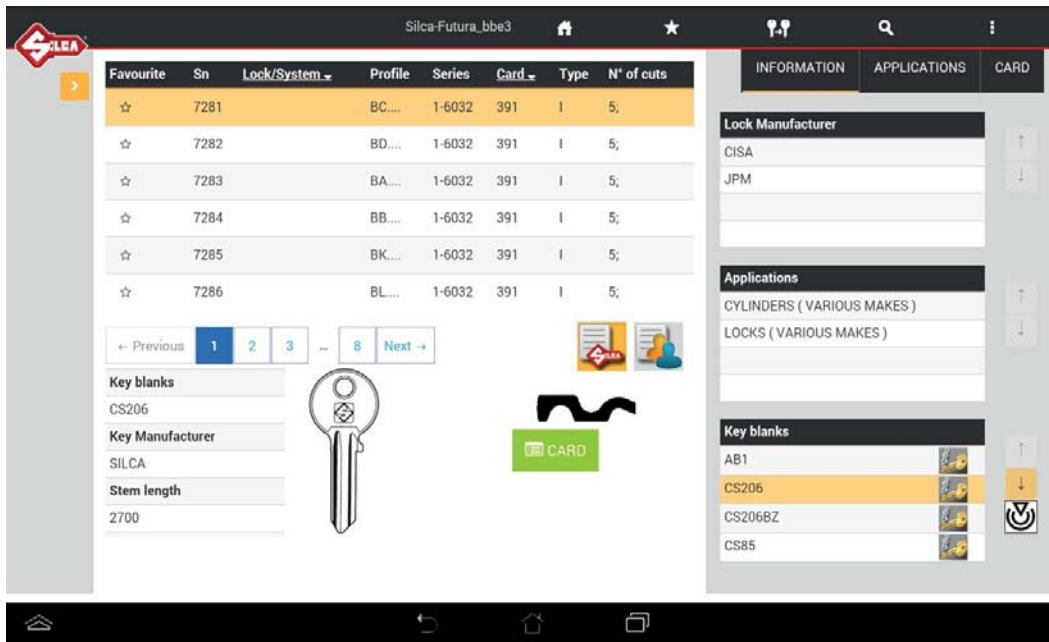

To access the cutting card select the relevant line and tap the “OPEN CUTTING CARD” button.

In the section of the window showing the search results

| Favourite | Sn | Lock/System | Profile | Series | Card | Type | N° of cuts |
|-----------|----|-------------|---------|--------|------|------|------------|
|-----------|----|-------------|---------|--------|------|------|------------|

- Order searches by tapping the arrow next to the relative fields.
- Select a series from those shown, or search for it on the next pages:
- Tap this icon to access the “Transponder Guide” (for vehicle keys).
- Select the “Silca” or “User” series:
 - “Silca” is the default icon for viewing Silca series.
 - tap “User” to view the existing user series (Ch.10) associated to the selected card.
- Tap the special field to enter the Hook position: it is automatically saved when the keyboard is turned off.

There are “3 folders” on the right of the screen:

INFORMATION: shows information about the lock make, applications and Silca/Ilo key blank. Info about a key can be viewed by tapping the field relating to the key blank.

APPLICATIONS: shows the applications for which this key blank is used: locks, cylinders, vehicle model, etc.

| INFORMATION | APPLICATIONS | CARD |
|------------------|--------------|------|
| Cylinders | | |
| ABUS | | |
| EC 75/30 | AB62 | |
| EC 75/40 | AB62 | |

CARD: shows information relating to accessories needed for cutting keys with the Futura / Futura Pro key-cutting machine.

| INFORMATION | APPLICATIONS | CARD |
|------------------|--------------|-----------|
| Clamp | | |
| 1 | 01R | D942570ZR |
| Right Jaw | | |
| 1 | 02J | D743254ZB |

KEY BLANK

To gain access to additional information regarding the Silca key blank simply tap on the following icon 

- List of other Silca key blanks that can be used
- List of comparative key blanks
- List of Brand names linked to the Silca key blank.

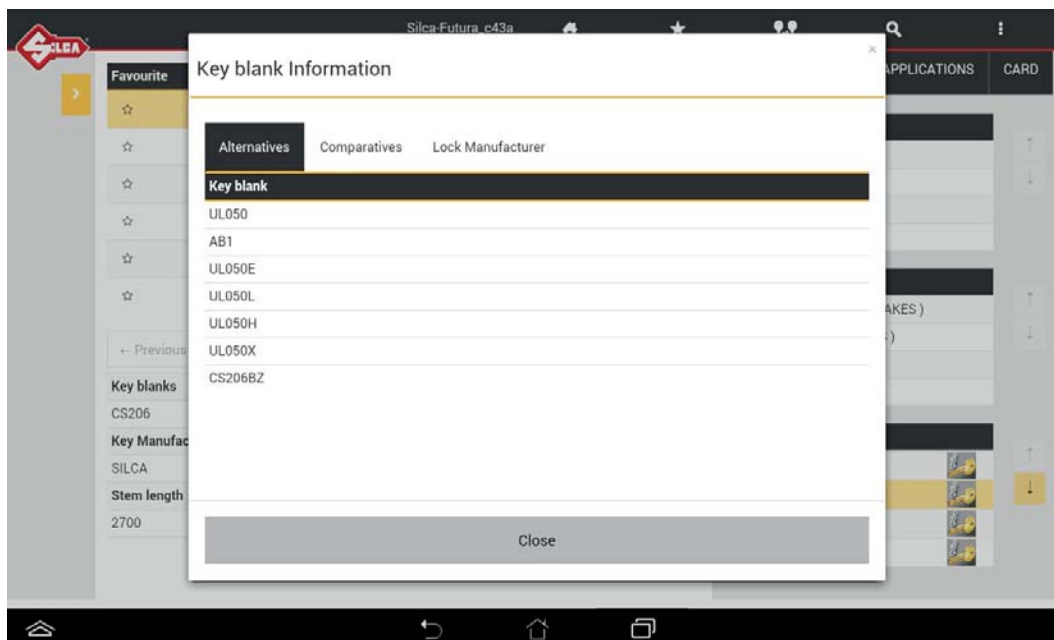

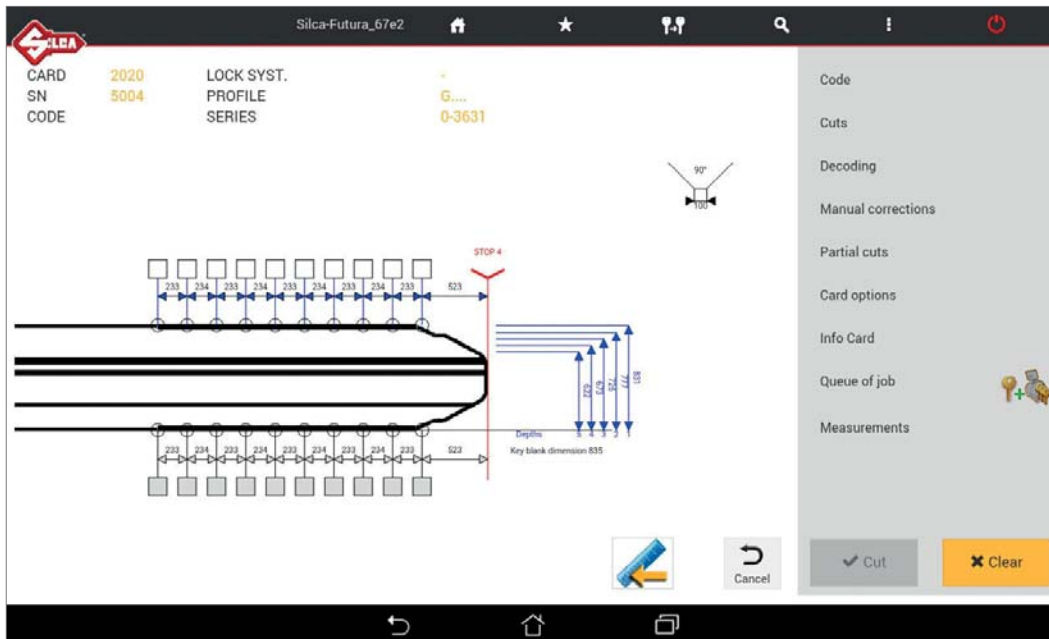

2.7 Using a CUTTING DATA CARD

Example:



The screen shows all the technical details relating to the selected cutting card (e.g. **Card, SN, Profile, Series, Spaces, Depth, Cutting angle**).

Tap the  Cancel key to go back to the previous screen.

Tap  to edit the way to view depths on the card:

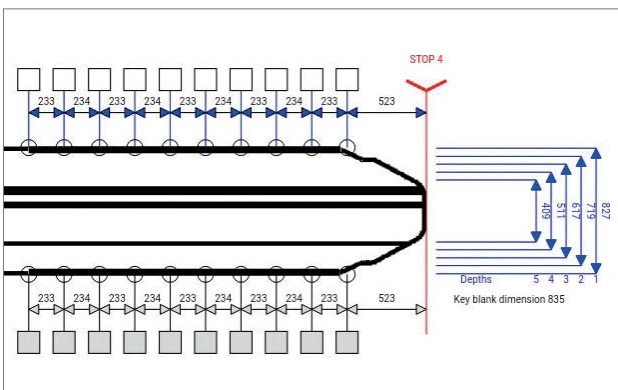

Fig. 1

Depths referring to the “key axis”

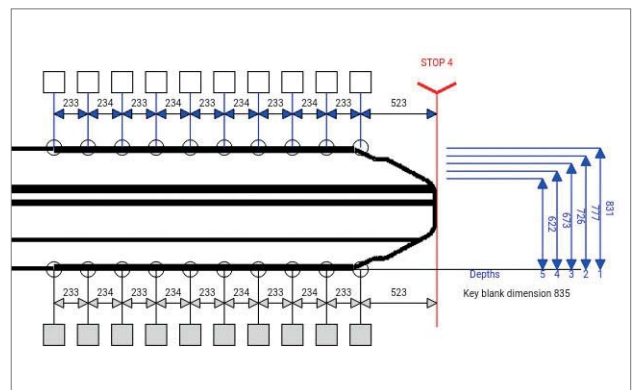

Fig. 2

Depths referring to “key back”
(i.e. the plate/bottom of the clamp)

Note: this function is only available for two sided symmetrical keys (standard and vehicles).

The list on the right contains the functions listed below:

- **CODE:** enter the indirect code for cutting the key.
- **CUTS:** this function is used to enter direct cuts.

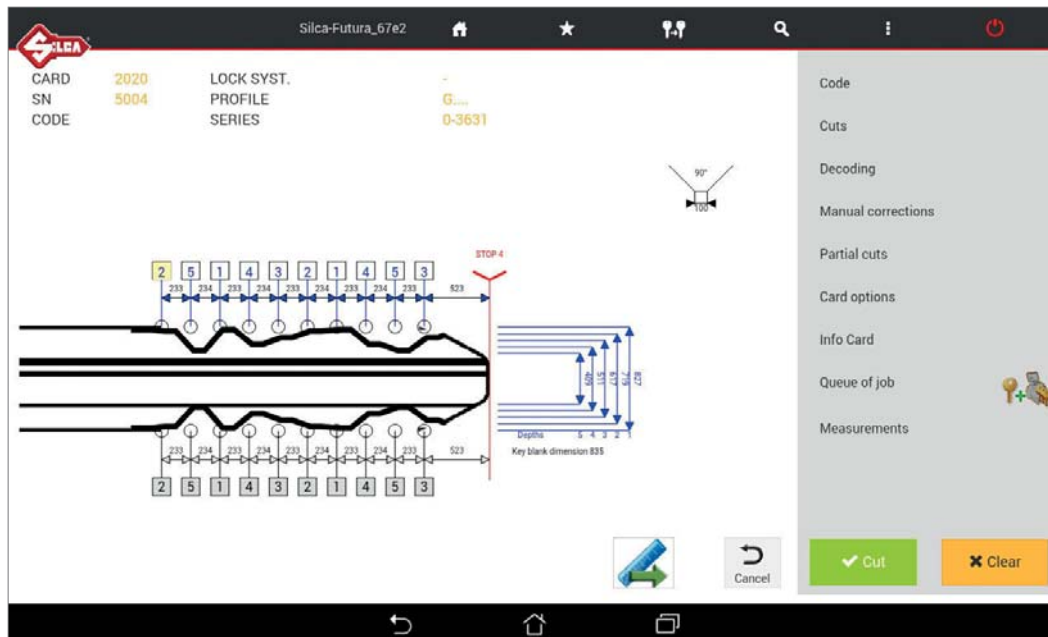

- **QUEUE OF JOB:** If the cut is filled and correct you can save your job in “Queue of Job” by tapping the following icon  (the job can then be done afterwards).

Tap on “Queue of Job” to display the list of jobs available.

- **DECODING:** used to decode the cuts on the original key.

ATTENTION: make sure the key to be decoded is clean.

ATTENTION: anodised aluminium dimple/laser keys, plastic keys or any other key without electrical conductivity **CANNOT BE** decoded! For these types of keys digit the cuts directly or enter the indirect code if the SSN in use allows it.

Tap “Decoding”: information appears regarding the position of the key in the clamp.

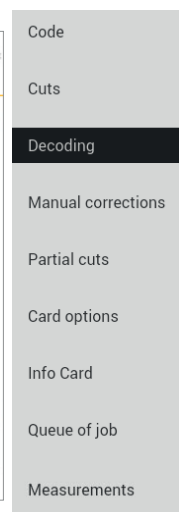
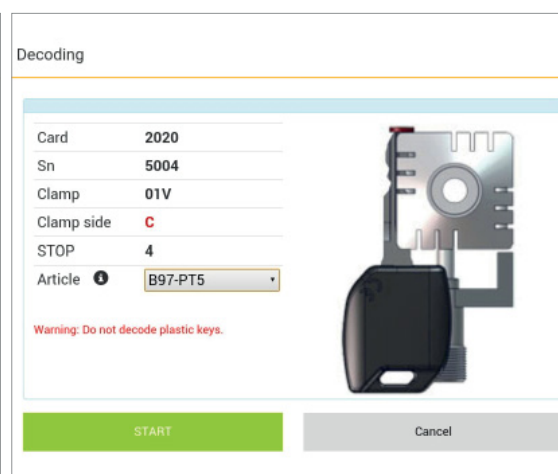
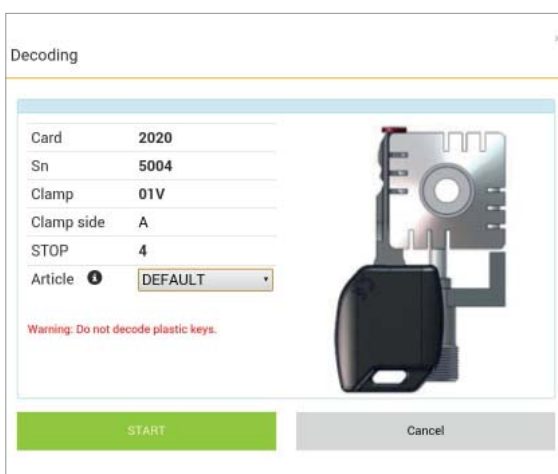

SELECT ARTICLE: to solve installation difficulties encountered with symmetrical vehicle keys on side A or B of the standard clamp, the user may select the key blank before decoding the key. In this way the machine will indicate the best side of the clamp (C or D) on which to fit the key and can run the decoding operation successfully.

To continue tap START and perform the operations described on the screen. At the end of the operation tap OK.

To view the decoded measurements and the measurements read on the key, tap “Decoded Values” on the bottom of the screen.

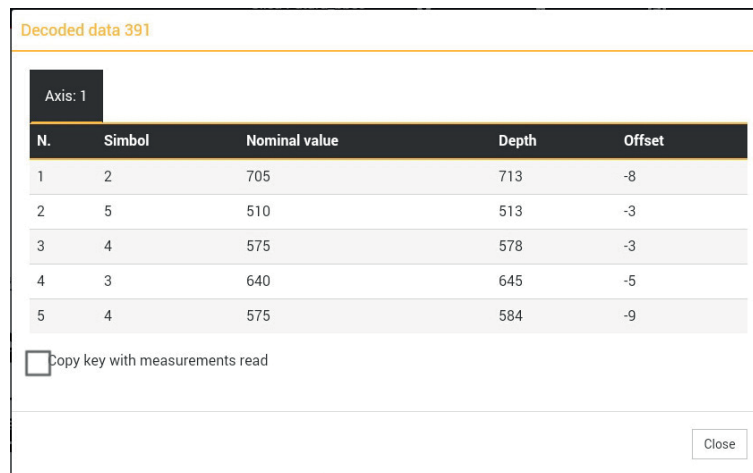

Decoded data 391

Axis: 1

| N. | Simbol | Nominal value | Depth | Offset |
|----|--------|---------------|-------|--------|
| 1 | 2 | 705 | 713 | -8 |
| 2 | 5 | 510 | 513 | -3 |
| 3 | 4 | 575 | 578 | -3 |
| 4 | 3 | 640 | 645 | -5 |
| 5 | 4 | 575 | 584 | -9 |

Copy key with measurements read

Close

Then tap “CUT” to cut the key using the combination provided by the previous operation.

Copy key with measurements read: after decoding a key the cuts can be verified and compared to the keys original cuts. If the cuts “Offset” values are significant, it’s possible to cut the key by using the measurements just read (not the keys original cuts nominal values that are in the card) by inserting a check “flag” in the appropriate box.

NOTE: when decoding standard keys, you must use the clamp side designated by the software as well as the stop position designated in order to decode the key properly. Use of other clamp positions or stop positions will result in a misread key. Once decoded, should you receive the message “key blank not allowed” or “bad permutation”, the key may not have been positioned properly. As a result the software will not recognize the key blank or the depths read will not correspond with any of the codes in the code series database. If you are sure that the proper card and key blank were used, reposition your key and try again.

- **MANUAL CORRECTIONS:** to enter manual adjustments in the relative fields for X axis and Y axis, activate the “Use corrections” flag, tap “Save” and then “Close”.

Adjustments: from -30 to +30 hundredths of mm (+/- 118 thousandths of an inch)

Close the window after it has shown an OK message.

An icon  indicates when the manual adjustment is active.

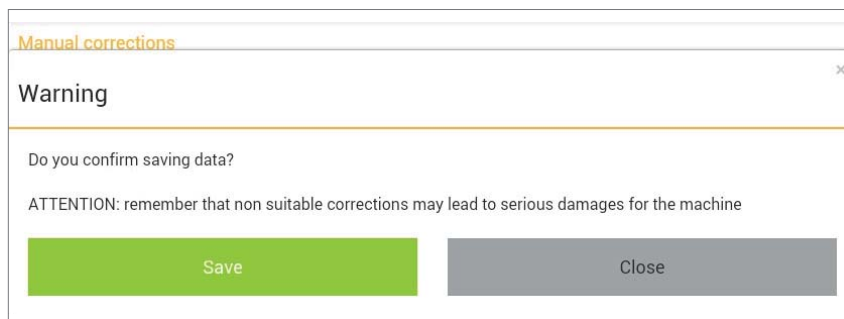
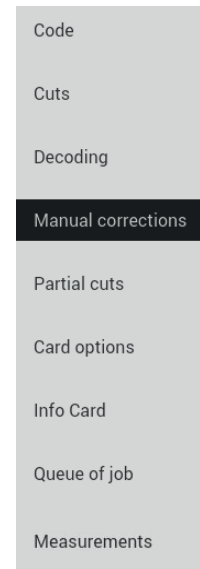
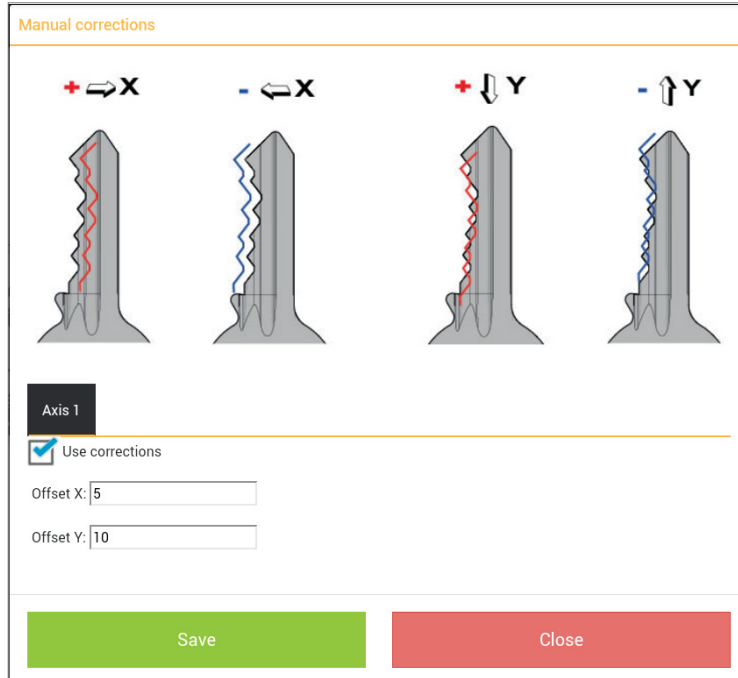

Confirm with “Save”.

- **PARTIAL CUTS:** used to make a search for correspondence with the code table (if applicable): enter the known cuts and tap “Search”.

Partial Cuts

Symbols

| Axis | Permutation |
|------|-------------|
| 1 | 5 2 3 |

| Code | Quantity | Axis 1 |
|-------|----------|---------------|
| BC782 | 1 | 5; 2; 3; 1; 1 |
| BC783 | 1 | 5; 2; 3; 1; 2 |
| BC784 | 1 | 5; 2; 3; 1; 3 |
| BC785 | 1 | 5; 2; 3; 1; 4 |

- Code
- Cuts
- Decoding
- Manual corrections
- Partial cuts**
- Card options
- Info Card
- Queue of job
- Measurements

Cutting tree: function accessible only from “Partial cuts” and enabled only for Data cards/Series with code tables available. Tap the “Cutting Tree” key to continue.

Cutting Tree

N° key blanks required: **4**
Codes selected: **Key n° 1**

| Code | Cuts |
|-----------------|-------|
| Key n° 1 | |
| BC782 | 52311 |
| BC783 | 52312 |
| BC784 | 52313 |
| BC785 | 52314 |
| BC789 | 52324 |
| BC790 | 52325 |
| BC795 | 52335 |
| BC796 | 52336 |
| BC802 | 52346 |
| BC803 | 52347 |
| BC853 | 52357 |
| BC858 | 52367 |
| Key n° 2 | |
| BC786 | 52321 |

- The list of keys shown in the cutting tree coincides with the list of keys shown in the “Partial cuts” window; however, here the keys are listed according to Groups, Code and Cuts in order to reduce to a minimum the number of key blanks to be used.
- The box at the top of the screen shows the maximum number of key blanks to be used for all the possible cut combinations listed.
- Each Group needs a new key blank to cover all the cut combinations it lists (work down from top). Select the group and/or single code and tap the QUEUE key to place them in the job queue.
- Tap Close, OK, and then Queue of Job.
- The jobs must be carried out in progressive order, starting from the key with the shallowest cuts to those with deeper cuts.

• CARD OPTIONS

Card options

Axis 1

Cut Type M_NORMALE_FLAT_LFD ▾

Cutter 01F ▾

Clamp 01V ▾

Key blank dimension 840

Ok

- Code
- Cuts
- Decoding
- Manual corrections
- Partial cuts
- Card options**
- Info Card
- Queue of job
- Measurements

Cut type: alternative cutting methods can be chosen from Flat, Track, Normal, Normal Easy;



NORMAL (M_NORMALE_FLAT_LFD)

For conventional car and door keys.



FLAT (M_PIANO_FLAT_LFD)

Mainly used for car keys where the cut edges are rounded to facilitate the movement of the blades when the key is put into the lock.



LASER (M_LASER_FLAT_LFD)

Conjunction of the cutting angles is determined automatically by the machine, allowing cuts to be made with variable angles; this facilitates the smooth entry of the key into the lock, prolonging the working life of the key.



NORMAL EASY (M_EASY_FLAT_LFD)

Concerns traditional automotive and door lock keys, the edges of the cuts are removed (when possible) by a defined value of around 30 hundredths of a millimeter. Likewise even for the keys tip.

Key blank dimension: used with the “Use any clamp” function.

Depth removal step (for DIMPLE keys only): this value indicates the amount of material trimmed by the cutter at each passage (example expressed in hundredths of a millimetre).

With keys that have SYMMETRIC CUTS the following window would appear:

Card options

Axis 1

| | |
|---------------------|------------------|
| Cut Type | M_LASER_FLAT_LFD |
| Cutter | 01F |
| Clamp | 01V |
| Key blank dimension | 810 |

Ok

- Code
- Cuts
- Decoding
- Manual corrections
- Partial cuts
- Card options**
- Info Card
- Queue of job
- Measurements

- **INFO CARD:** views information about the clamp, side and stop to be used, cutter and key blank.

Tap the relevant icons ⓘ to see images and part code.

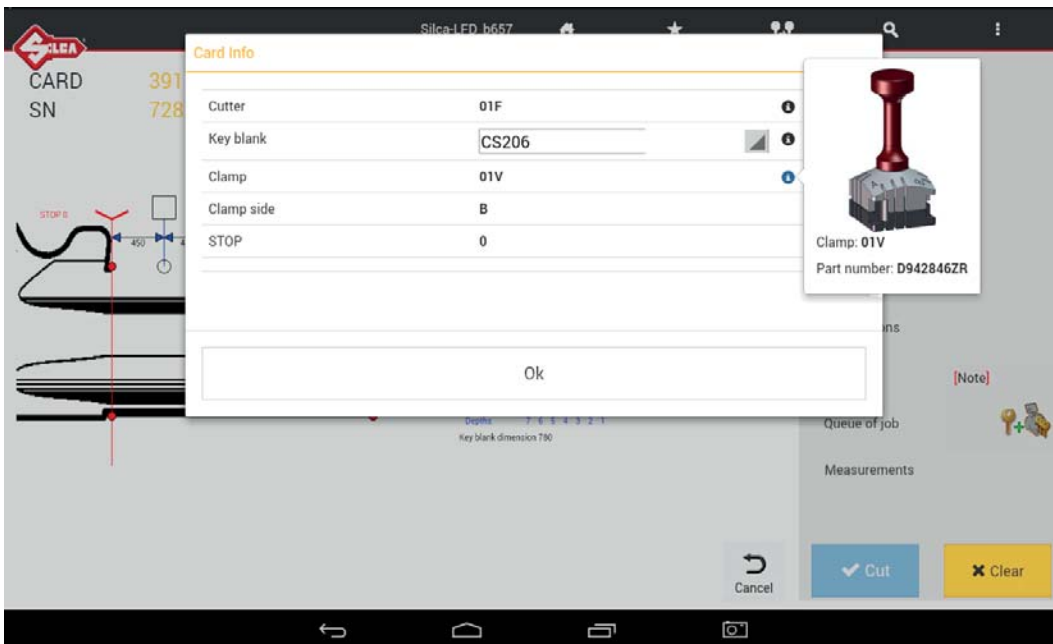

- Code
- Cuts
- Decoding
- Manual corrections
- Partial cuts
- Card options
- Info Card**
- Queue of job
- Measurements

- **[Note]:** tap “Note” (when shown) to view data card notes, i.e. further specific information relating to the position of the key or an accessory, etc.

- **MEASUREMENTS:** view information regarding the measurements of SPACES and DEPTH on the card.

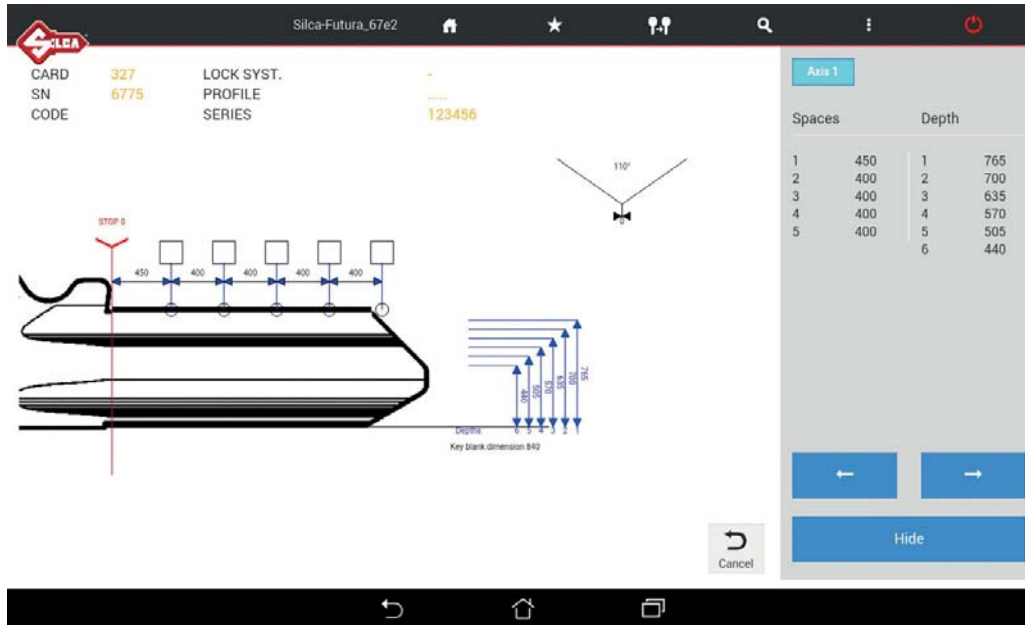

- Code
- Cuts
- Decoding
- Manual corrections
- Partial cuts
- Card options
- Info Card
- Queue of job
- Measurements**

2.8 CUTTING STANDARD flat keys (cylinder and vehicle)

To make a cut on the key, tap CUT  : information is shown about the position of the key in the clamp.

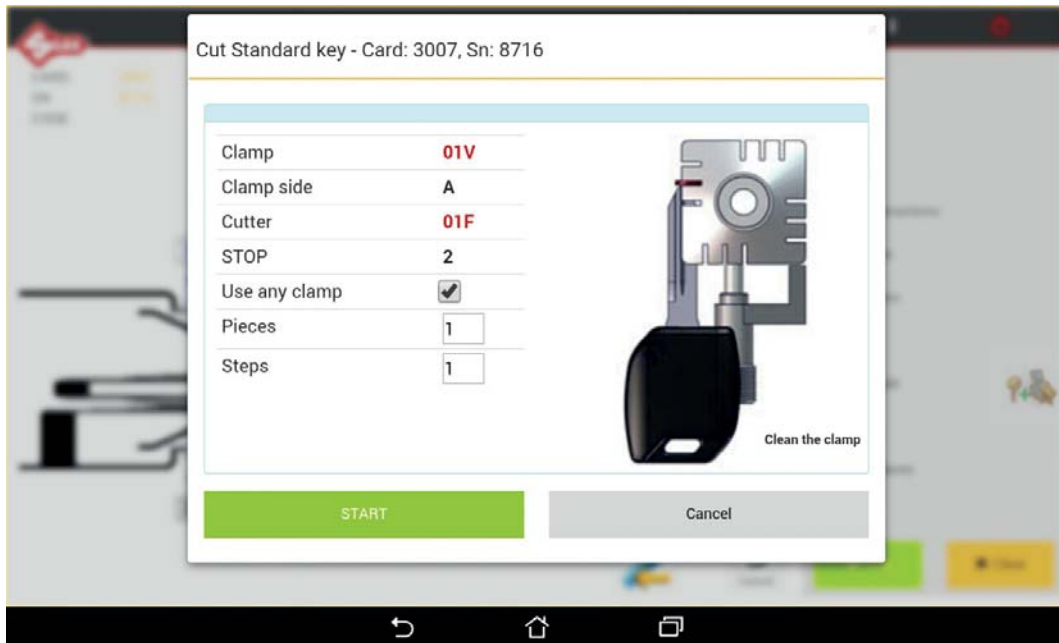

The following can be set:

Use any clamp: if this function is enabled the key to be cut can be positioned on a clamp side different from default. The function is used to acquire the measurement of the key blank (stem width) in order to adapt cuts to the key blank being used. It is applied automatically only to keys with double symmetrical sides.

ATTENTION: option valid for **CUTTING** only (NOT DECODING).

NOTE: activating the "Use any clamp" allows the user to clamp the key in any jaw position (i.e. clamping the keys profile on side C or D) when cutting a key by code. Regardless of the jaw position used, the stop position designated by the software must be used. This function is only available when cutting two symmetrical sided standard keys. When this function is enabled cuts cannot be repeated on a key already cut.

Pieces: indicates how many keys you wish to cut.

Steps: used to edit the default number of passes during key cutting (max +2). The value is memorised once it has been edited.

2.9 Cutting DIMPLE/TRACK/TUBULAR keys and CUTTING SPEED

To make a cut on the key, tap CUT  : information is shown about the position of the key in the clamp.

1) For DIMPLE keys

Cutting speed change (relates to carriage advancement).

NOTE: the default value set by Silca is 100.

To change the Silca settings, tap the required value:

- With a value of 110 (the carriages will advance at a speed 10% higher than the default setting).
- With a value of 90 or 80 (the carriages will advance 10% or 20% more slowly than the default setting).

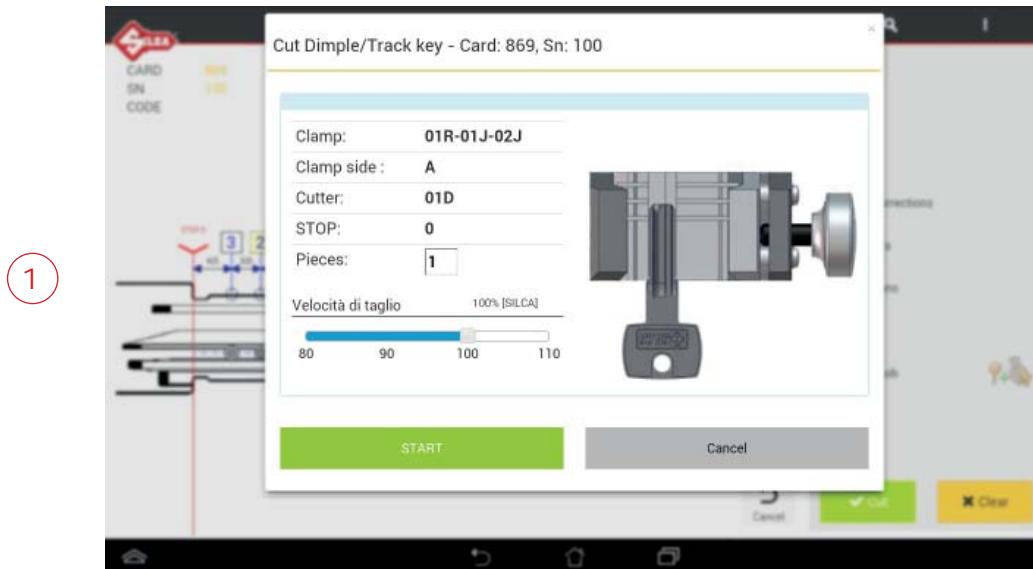

2) For TRACK keys

Steps: used to edit the default number of passes during key cutting. The value is memorised once it has been edited.

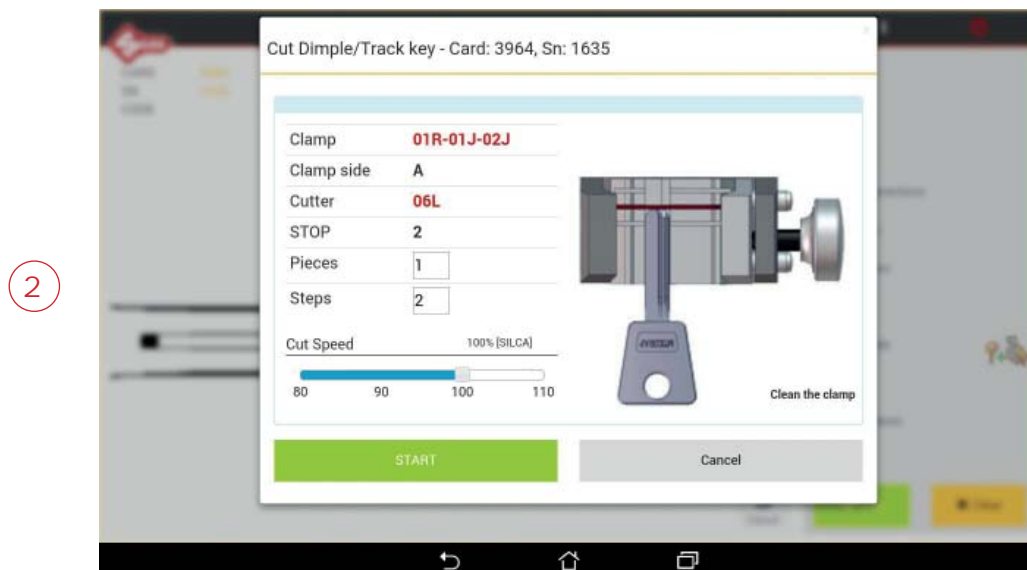

The following can be set:

Pieces: indicates how many keys you wish to cut.

Press START to begin the procedure.

3 COPY BY ORIGINAL

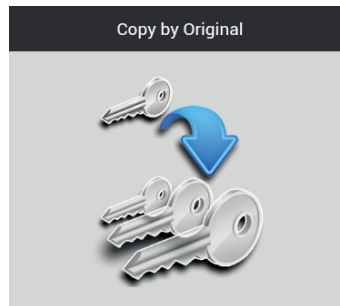

Tap **“Copy by Original”** to start the procedure for copying an original key using the laser reader as an optic reader device.

This operation can be used only for the types of keys cut on clamp 01V.

The “Copy” procedure is divided into two steps: first load the original key to be read into the clamp 01V, once the key has been read, remove the original and load the key blank to be cut.

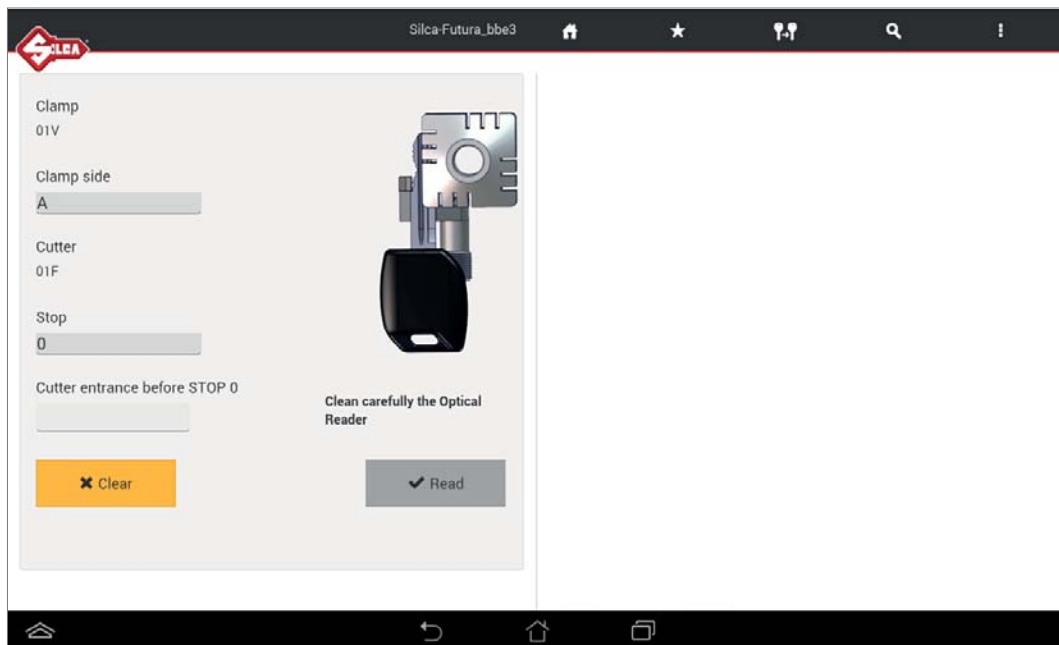

In the Left-hand Part of the screen:

- Select the clamp side (A-B-C-D) to be used for reading and cutting the key.
- Select the type of Stop involved (0-1-2-3-4)
 - in the case of Stop 0 the gauge is used to align the key stop
 - with Stops (1-2-3-4) a bar is used to align the stop with the key tip.
- The Distance field is used when the stop selected is 1-2-3-4 and there is an indication of the point at which the optic reader will start reading the original key. Normally this point equals Stop 0 which refers to the position of the gauge/key stop.

Range [0 / -400 hundredths of mm] => insert only NEGATIVE value.

NOTE: *clean the optic reader carefully with the brush provided before starting the “Copy by Original” procedure.*

When the key has been read, the following can be set:

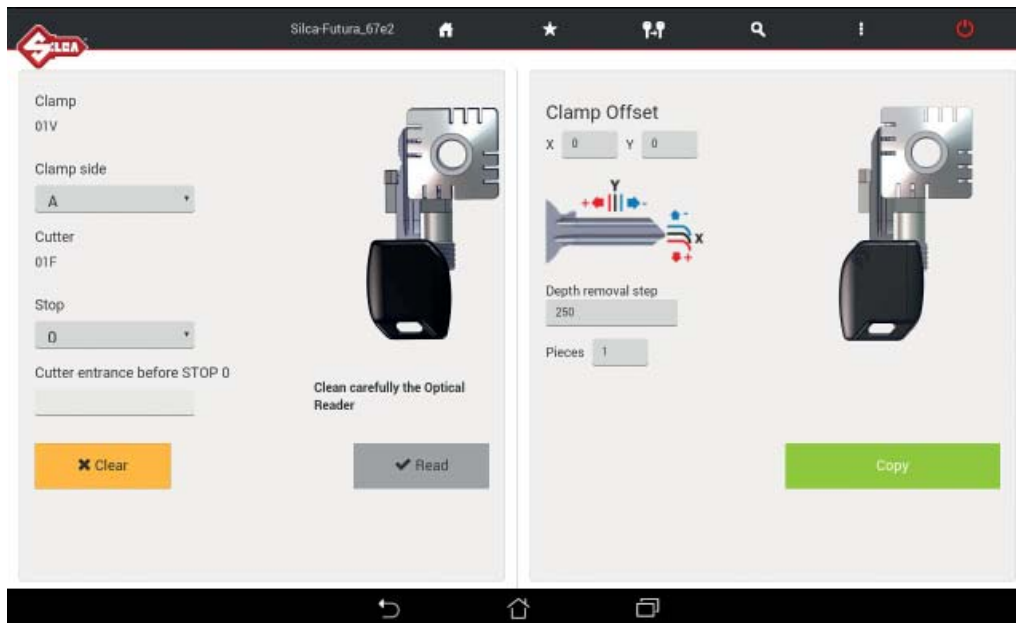

Manual adjustments

Manual adjustments can be made to Y and X only if strictly necessary.

Positive value of Y: move cut closer to stop.

Negative value of Y: move cut away from stop.

Positive value of X: lower the cut.

Negative value of X: raise the cut.

Adjustments admitted: -30 to +30 hundredths of a millimetre. Press "Save" to confirm.

Pieces: indicates how many keys will be cut.

Remove the key just read from the clamp and load the key blank to be cut, positioning with the same Stop and Clamp Side used during the reading process.

Tap "Copy" to start key cutting.

NOTE: the Copy by Original function will cut the key exactly as read if no manual adjustments are made. If you are copying a worn key and do not make manual adjustments, the cut key will be an exact duplicate of the original worn key. To copy a worn key back to OEM specifications you should use the "Search" function to identify the card or code series used for the original key. Once the proper card is opened, select "Decoding" on the right side of the card menu. This will measure the cuts based on the depth data used by the OEM and the software will make adjustments to the depths measured and cut the duplicate key back to OEM specifications.

4 FAVORITE'S

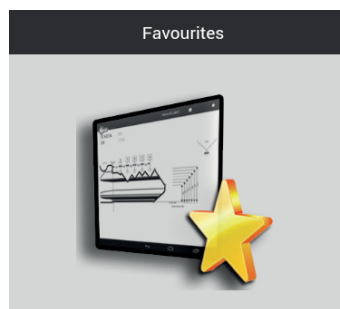

The FAVORITES menu contains the data cards that have been selected in the Search menu (Standard keys, Vehicle keys, Dimple/Track keys). Saving data cards to the favorites menu will eliminate the time spent searching for frequently used cards.

For each data card a description can be written in the special field in the “User Note” column.

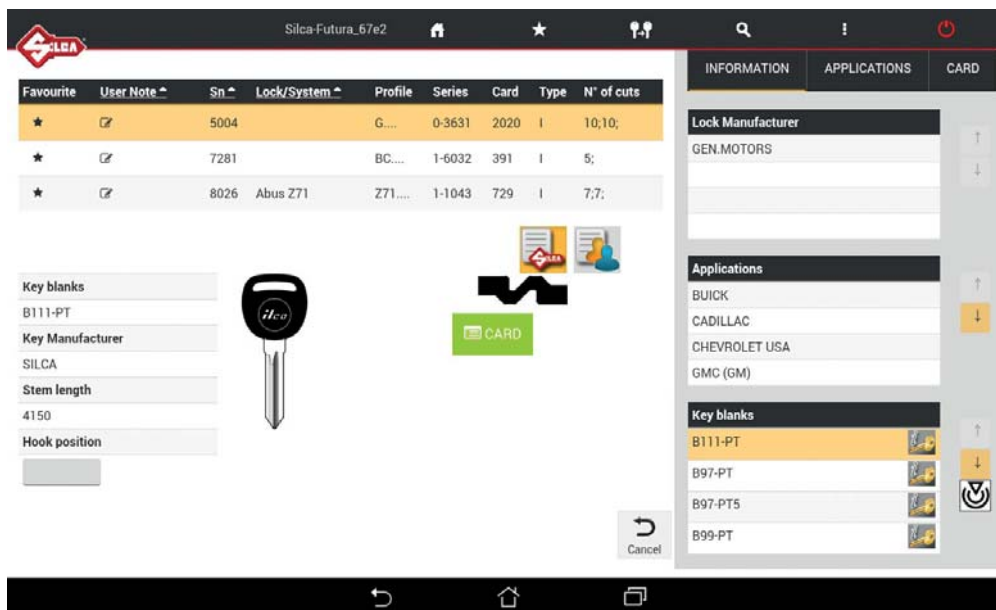

To select data cards to be included in the Favorite's menu tap the star symbol ☆ in the first left-hand column of the Search menu; the symbol will be highlighted in black.

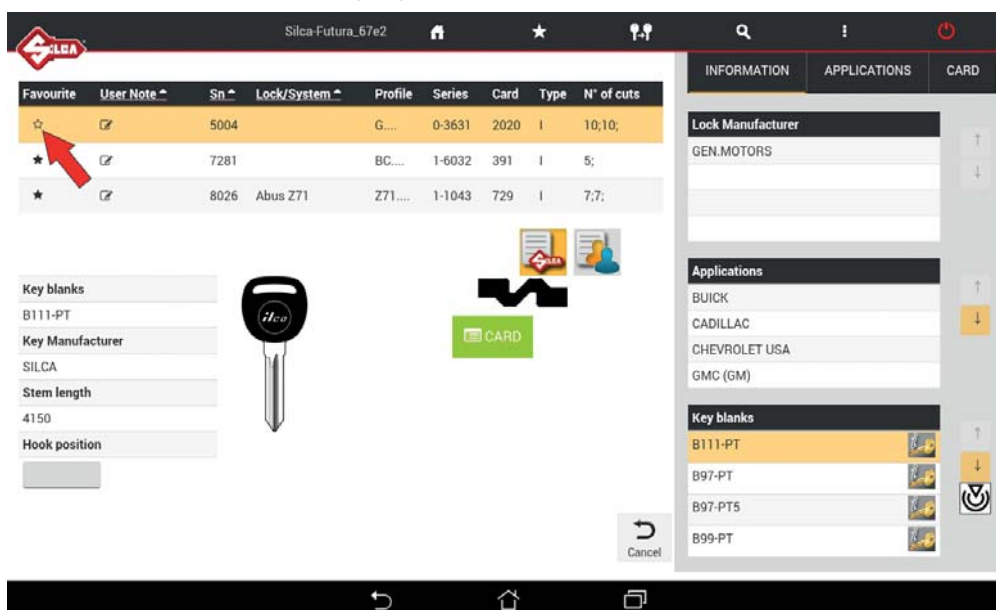

To remove a data card in the Favorite's menu, tap the relevant star symbol, which will go back to white.

5 QUEUE OF JOBS

The “Queue of Jobs” collects all the jobs (the keys) the user prefers to do later. See on page 17 how to move a job in this “Queue of Jobs”.

5.1 “STANDARD” QUEUE OF JOBS

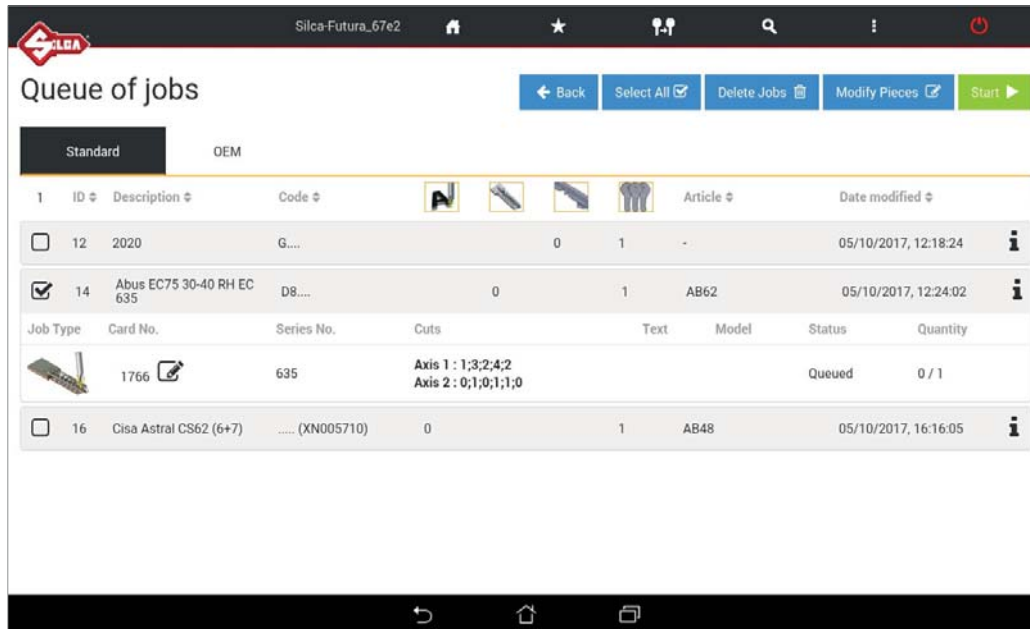

- Select one or more jobs using the “Select All” button, or tap the box.
- To see other job details, tap the single row.
- To delete the selected jobs, tap “Delete Jobs”.
- To edit the number of keys to be cut in the selected jobs, tap “Modify Pieces”.
- To start cutting the selected jobs, tap “Start”.

ICON LEGEND

- Total number of keys to be cut
- Number of DIMPLE cuts already made
- Number of STANDARD cuts already made
- Number of ENGRAVINGS already done
- Identifies DIMPLE cuts
- Identifies STANDARD cuts
- Identifies ENGRAVING
- Extra information

5.2 “OEM” QUEUE OF JOBS (only with OEM CLIENT function enabled)

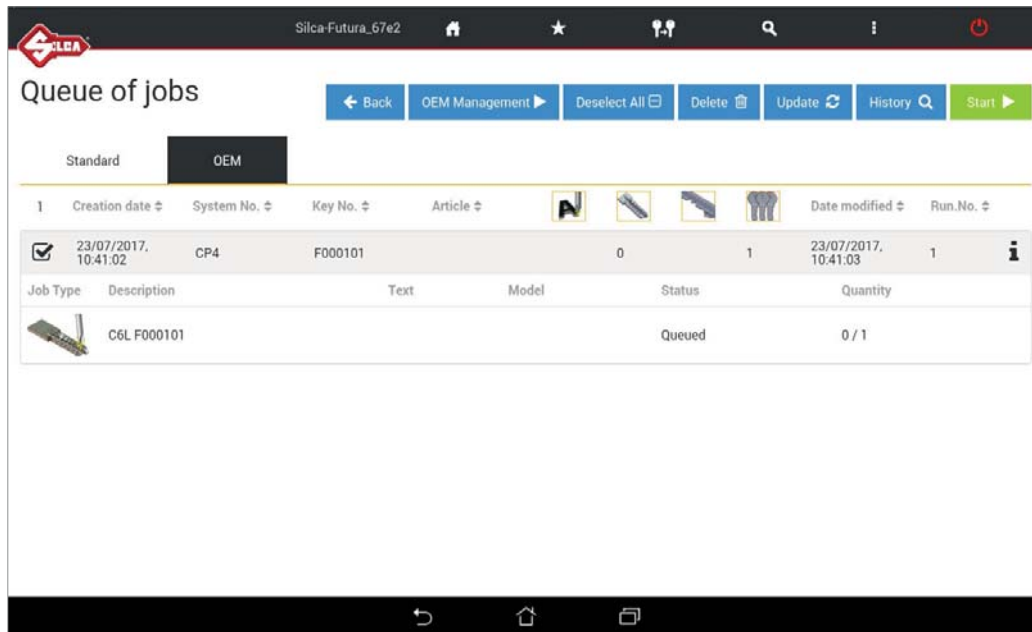

OEM jobs are copies of keys regulated by the manufacturer (OEM) through the OEM CLIENT function:

- **the manufacturer provides the information needed to cut the key.**
- **the manufacturer confirms the number of copies to make.**

When users have been authorised by the manufacturer and enabled by Silca, they can use the OEM CLIENT function to request and/or receive the data needed to cut the key and save them in the special OEM QUEUE. The OEM QUEUE function will guide the user through all the operations required to cut the key in a controlled, easy way.

According to the decision of the manufacturer, the jobs ordered may include:

- **a job to engrave a code on the head or stem of a key blank.**
- **one or more cutting operations.**

The user must carry out all the jobs defined by the manufacturer and follow instructions to the letter.

If an ENGRAVING job is included in the queue the user must have already created an ENGRAVING model with the same name and characteristics as the one proposed by the manufacturer. Otherwise no engraving job will be created. See the ENGRAVING section of the Software Guide (see Ch.6).

5.2.1 OEM CLIENT function activation

- Users who wish to use the special OEM CLIENT function must make a request to both the manufacturer and Silca. Consult the Silca sales network for information regarding which manufacturers allow this function to be used.
- When users have been authorised by the manufacturer and have applied to be enabled by SILCA they must unlock the OEM CLIENT function on board the machine by downloading a specific software update for their own FUTURA cutting machine.
- After the software update, check that enabling has been activated by selecting the INFORMATION window and checking the ENABLE OEMs section (Fig. 3).

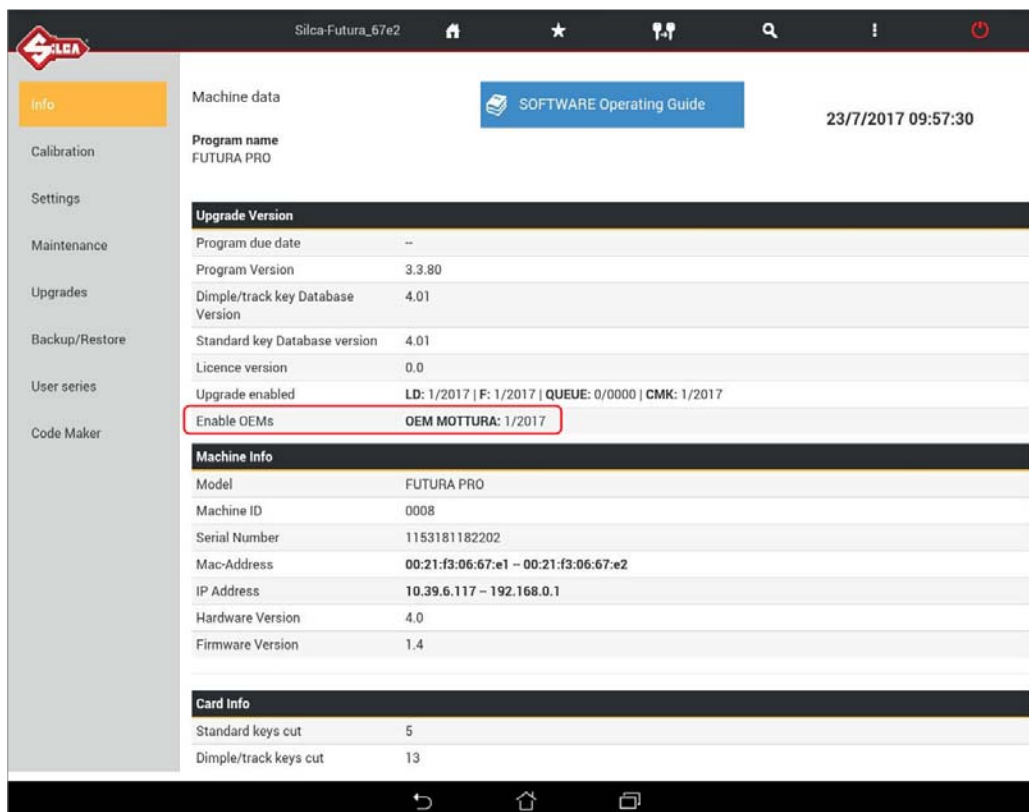

Fig. 3

IMPORTANT: for further details provided by each manufacturer about machine configuration and key cutting, consult the ONLINE HELP available in the 'OEM QUEUE' -> "OEM Management" section.

6 ENGRAVING

The ENGRAVING function software comes free for all FUTURA PRO and FUTURA key-cutting machine models.

The function is enabled by default. To disable and to hide certain engraving keys and fields, edit the parameter in the section:

OPTIONS menu -> Settings -> Options -> Preferences DIMPLE/TRACK keys

The ENGRAVING function requires the following accessories:

- **Jaw 01E (code D748737ZB)**
- **Jaw 02E (code D748739ZB)**
- **Cutter 18DW (specific for engraving) (code D748741ZB)**

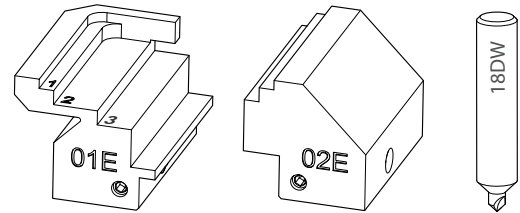

The accessories are:

STANDARD on the FUTURA PRO ENGRAVING version

OPTIONAL for all other versions of FUTURA and FUTURA PRO

Fig. 4

Select the ENGRAVING icon to enter the list of ENGRAVING MODELS created by the User.

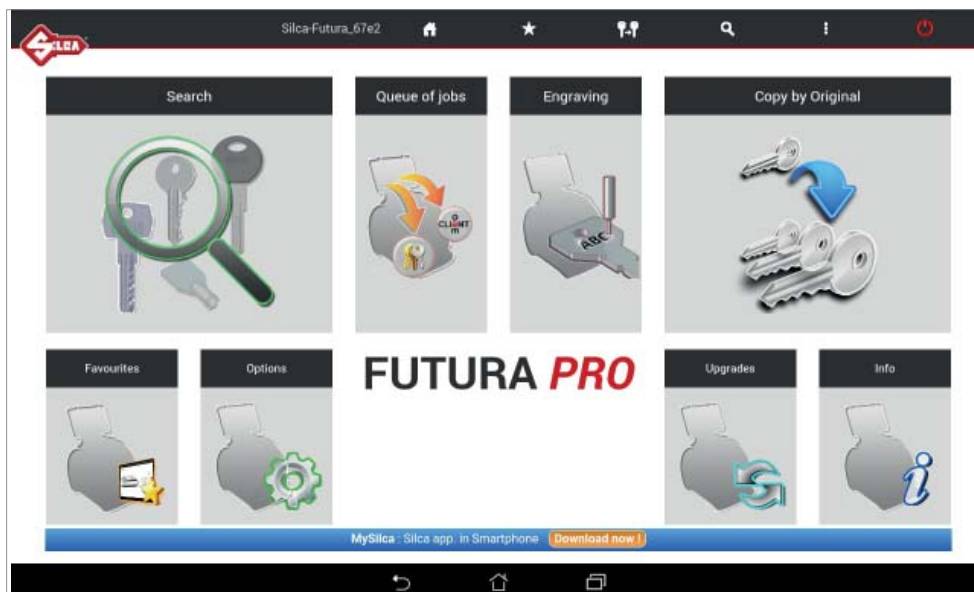

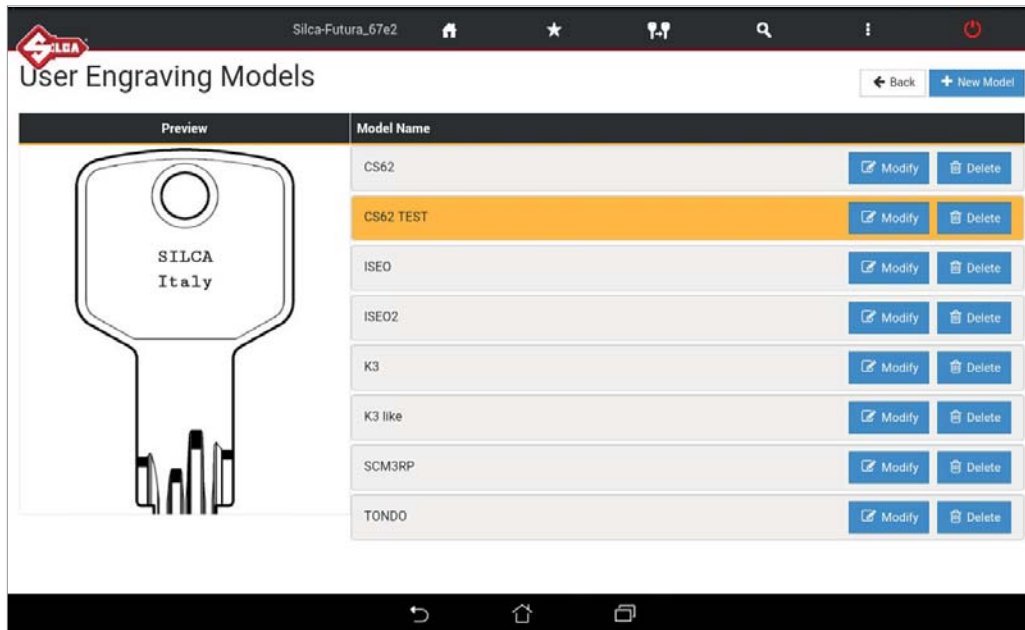

This makes it possible to:

- **CREATE** a new User Model
- **MODIFY** a User Model
- **DELETE** a User Model

Tap 'New Model' or 'Modify' to enter the User Model Editor function.

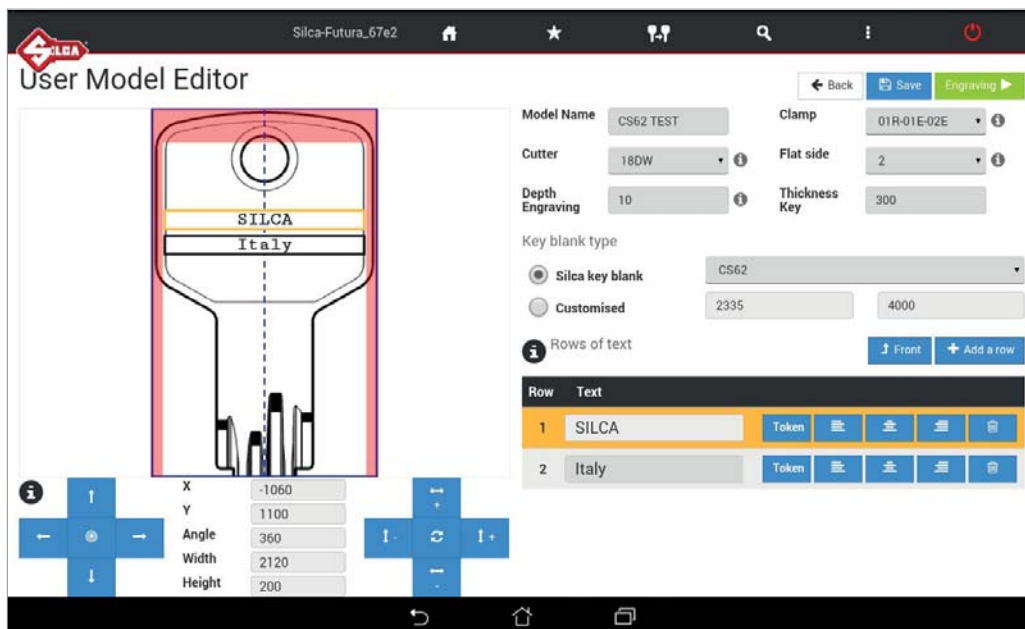

The ENGRAVING model defines all the parameters the machine requires to engrave a text on a key head or stem or on flat surfaces such as medals or metal plates.

ATTENTION: objects MUST BE METAL, NOT STAINLESS STEEL. Materials such as wood, paper, plastic and ceramics cannot be engraved. Make sure the surface of the object to be engraved is flat.

Model creation procedure:

• **GENERAL PARAMETERS**

- Assign a Model Name
- Select a clamp (default: 01R-01E-02E)
- Select a cutter (default: 18DW)
- Set engraving depth (default 10 hundredths of a millimetre)
- Set Thickness for the key or object to be engraved (max 520 hundredths of a millimetre)
- Select the PLANE on which to fit the object to be engraved, according to its dimensions.

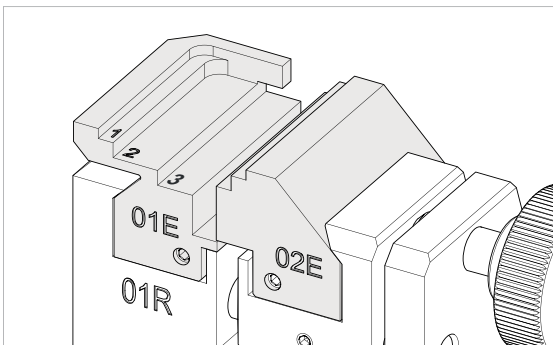

Fig. 5

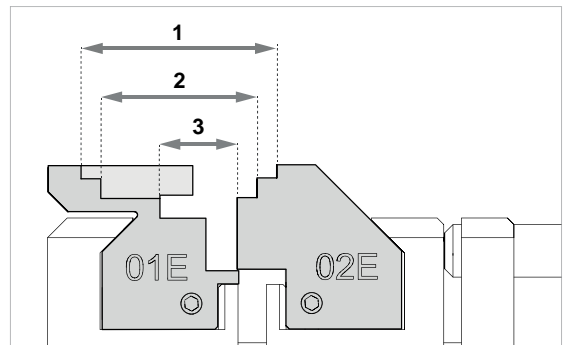

Fig. 6

| PLANE | WIDTH of the object to be engraved | ENGRAVING AREA (L x H) |
|-------|---------------------------------------|---------------------------|
| 1 | min 26 - max 32 mm | 32 mm x 40 mm |
| 2 | min 20 - max 26 mm | 24 mm x 36,5 mm |
| 3 | min 8 - max 14 mm | 12 mm x 36,5 mm |

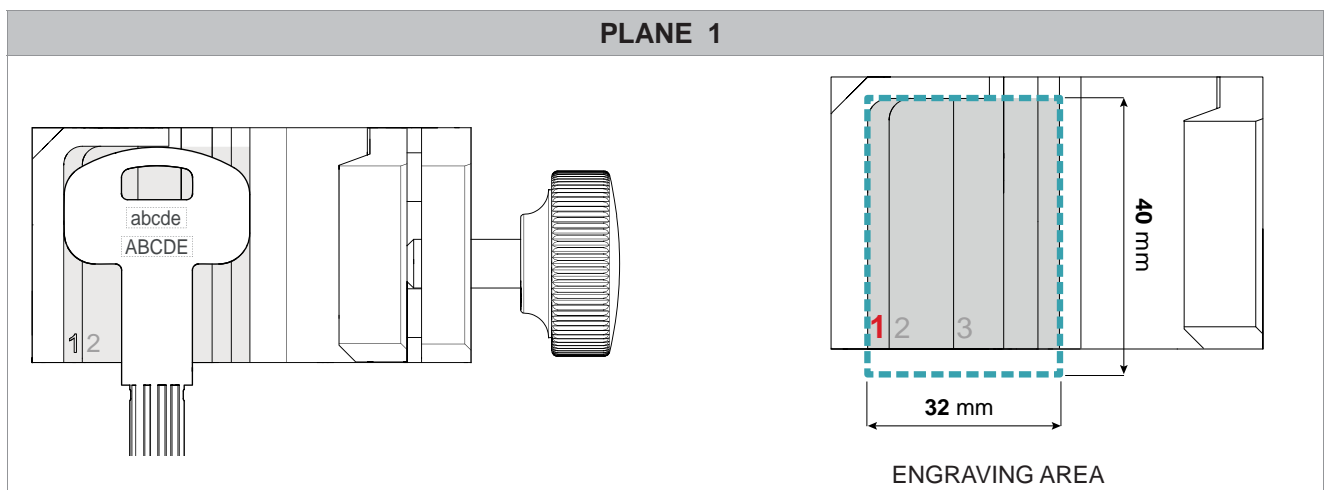

Fig. 7

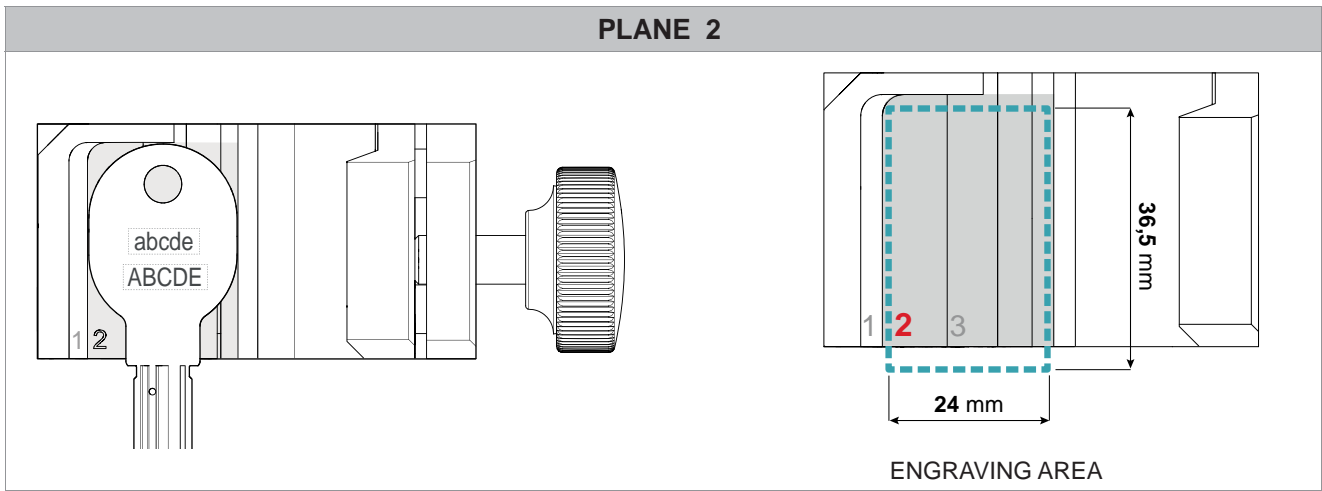

Fig. 8

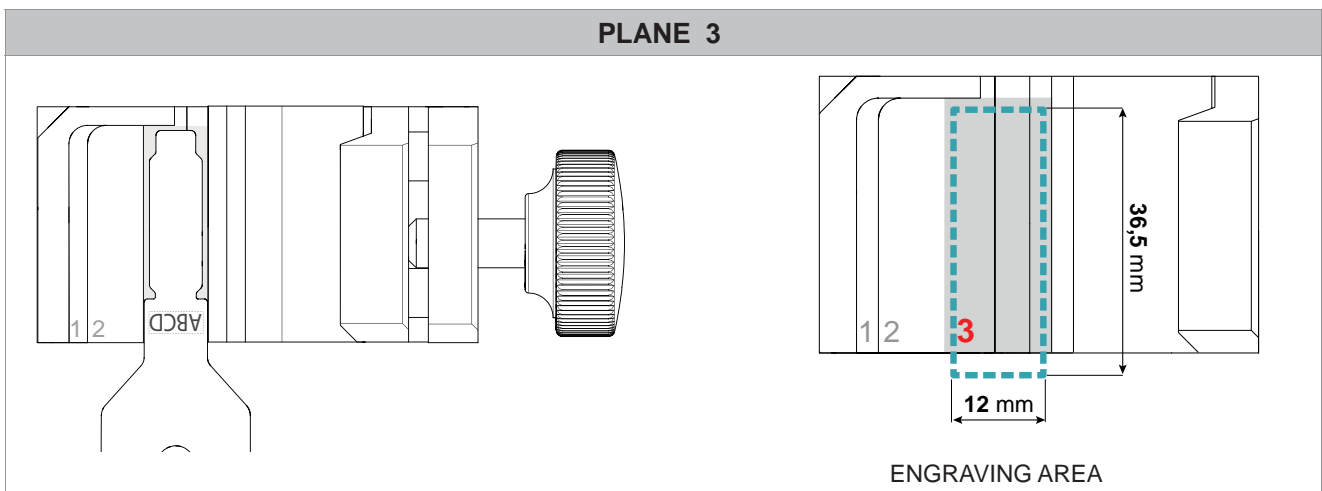

Fig. 9

- **TYPE OF OBJECT TO BE ENGRAVED (key or other)**

- Select '**SILCA key blank**' to choose a key blank similar to or the same as the SILCA one for which an example of an engraving Model has already been created.
- Select '**Customised**' to choose the dimensions of a circular or rectangular object to be engraved.

• **ROWS OF TEXT**

| | |
|-------------|--|
| + Add a row | To add the rows of text for one side only (FRONT) or both sides (FRONT and BACK) of the object to be engraved. |
| ↑ Front | |
| ↓ Back | |
| ☰ ☱ ☲ | To align the text R or L or CENTRE (default) for every row. |
| 🗑️ | To remove the selected row of text. |
| Token | Select the TOKEN button to assign the 'type' to the current row. The 'type' of row may be a free text or a token. The token 'type' cannot be edited directly by the User, but is assigned suitable value with a figure available in the context of the model's use. E.g: |

| | |
|---------------|--|
| T [00] | Replaced with an INDIRECT cutting CODE |
| T [03] | Replaced with the PROFILE field for the lock system involved |
| T [04] | Replaced with the SERIES field for the lock system involved |

Tokens are mainly used for OEM applications or the production of master key systems for which files containing special information are provided, as below:

| | |
|---------------|--|
| T [00] | Replaced with the name or number of the key in a master key system |
| T [05] | Replaced with the number or name of a master key system |
| T [10] | Replaced with the 'Progressive Counter' field for a key in a master key system |

Select type of row ✕

| Type of row | Description |
|---------------------------------|-------------|
| Text | Free text |
| Code Key [T00] | |
| Code Cylinder [T01] | |
| Customer [T02] | |
| Profile [T03] | |
| Series [T04] | |
| System No. [T05] | |
| Constant part of key code [T06] | |
| Variable part of key code [T07] | |
| Increase function 1 [T08] | |
| Increase function 2 [T08] | |
| Note [T09] | |
| Progressive counter [T10] | |
| User 1 [T11] | |
| User 2 [T12] | |

Cancel
Select

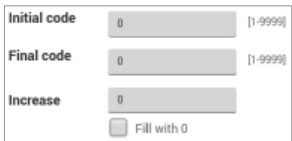
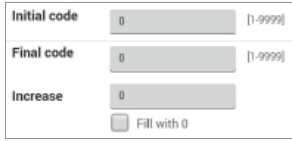
| | |
|----------------------------|---|
| Text | Free text |
| T[00] | Replaced with an INDIRECT cutting CODE or Replaced with the name or number of the key in a master key system |
| T[01] | Used for special applications |
| T[02] | Replaced with customer Name assigned to a master key system |
| T[03] | Replaced with the PROFILE field for the lock system involved |
| T[04] | Replaced with the SERIES field for the lock system involved |
| T[05] | Replaced with the number or name of a master key system |
| T[06] | Replaced with the constant part of an INDIRECT cutting CODE |
| T[07] | Replaced with the variable part of an INDIRECT cutting CODE |
| Increase Function 1 | <p>A progressive number is printed on the basis of the set parameters. The numerical sequence can be filled by zeros to maintain the width of the text unaltered.</p> <p>Example:</p>  <p>- 01 - 02 - 03 - ..</p> |
| Increase Function 2 | <p>A sequence of progressive numbers linked to the set pieces is printed. Used to mark all the keys in sequence before cutting them. The numerical sequence can be filled by zeros to maintain the width of the text unaltered.</p> <p>Example:</p>  <p>setting a quantity of 2 results in:</p> <p>- 01 - 01 - 02 - 02 - 03 - 03 - .. - 10 - 10</p> <p>To obtain this result, when 2 pieces are finished, repeat the operation until the required sequence is ended.</p> |
| T[09] | Replaced with a note field for a master key system |
| T[10] | Replaced with the 'Progressive Counter' field for a key in a master key system |
| T[11] | Used for special applications |
| T[12] | Used for special applications |

• **POSITIONING TEXTS WITHIN THE ENGRAVING AREA**

| | | | | | | | | | | | |
|---|--|------------------------------------|----------|-----------------------------------|--------------|----------------------------------|--------------|-----------------------------------|---------------|----------------------------------|---|
| | <p>To MOVE the text area (right, left, up, down).</p> <p>Centre button for CENTRING the text area inside the engraving area.</p> | | | | | | | | | | |
| | <p>To make the height or width of the text area SMALLER or LARGER.</p> <p>Centre button for ROTATING the text area by increases of 90°.</p> | | | | | | | | | | |
| <table border="0"> <tr> <td>X</td> <td><input type="text" value="-1060"/></td> </tr> <tr> <td>Y</td> <td><input type="text" value="1100"/></td> </tr> <tr> <td>Angle</td> <td><input type="text" value="360"/></td> </tr> <tr> <td>Width</td> <td><input type="text" value="2120"/></td> </tr> <tr> <td>Height</td> <td><input type="text" value="200"/></td> </tr> </table> | X | <input type="text" value="-1060"/> | Y | <input type="text" value="1100"/> | Angle | <input type="text" value="360"/> | Width | <input type="text" value="2120"/> | Height | <input type="text" value="200"/> | <p>To fine tune positioning and dimensions of the row of text, all the measurements viewed can be edited.</p> |
| X | <input type="text" value="-1060"/> | | | | | | | | | | |
| Y | <input type="text" value="1100"/> | | | | | | | | | | |
| Angle | <input type="text" value="360"/> | | | | | | | | | | |
| Width | <input type="text" value="2120"/> | | | | | | | | | | |
| Height | <input type="text" value="200"/> | | | | | | | | | | |

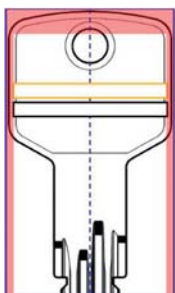

ATTENTION: the **RED** area corresponds to a safety zone which must be out of the tool's reach. Each clamp plane (1, 2 and 3) has a different area.

The User Model Editor monitors the position of the rows of text so that they do not interfere with the safety zone.

• HOW TO USE AN ENGRAVING MODEL

1) From a CUTTING CARD

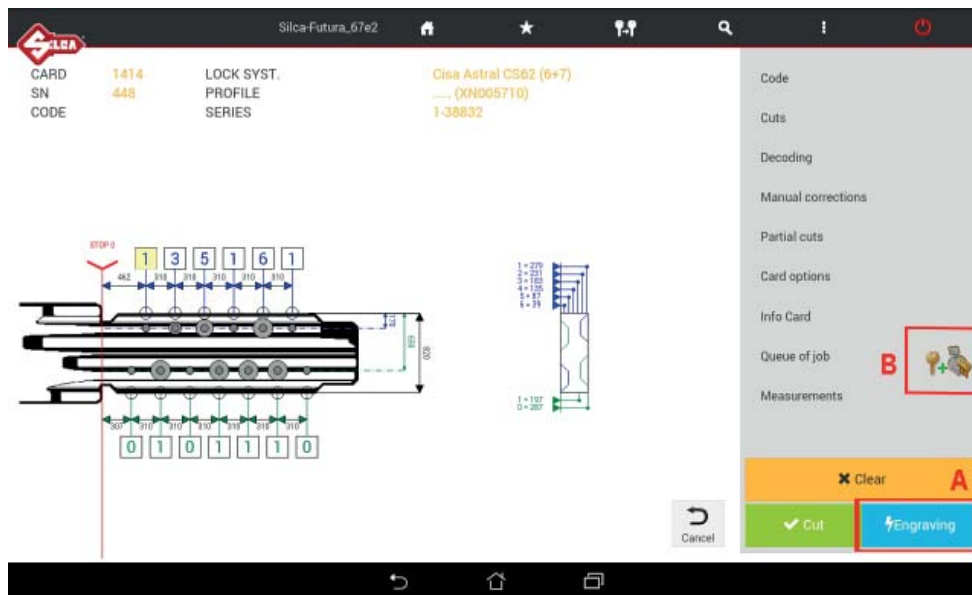

A - Tap ENGRAVING to view:

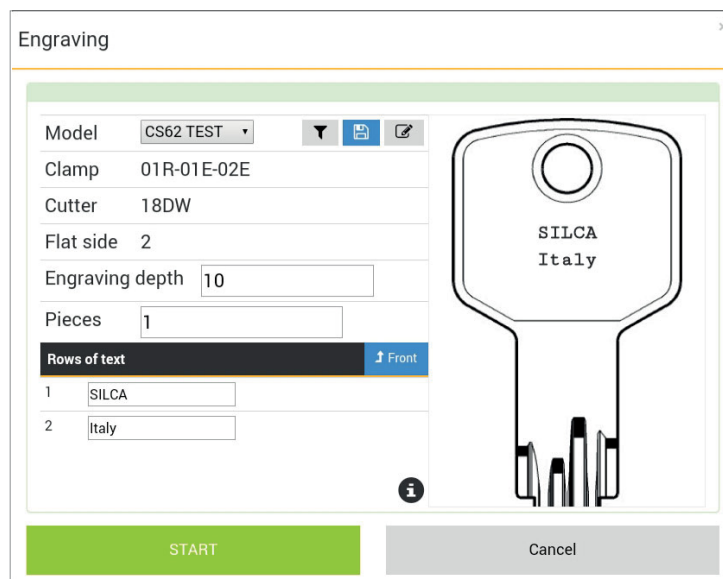

This window makes it possible to:

- Select a User Engraving Model or Predefined SILCA from the list and then associate it permanently with the cutting card by tapping
- Filter the list of models so that it contains only USER MODELS + models relating to key blanks linked to the current cutting card by tapping
- Edit the selected Model by tapping
- Edit the number of pieces
- Temporarily edit the ENGRAVING DEPTH
- Temporarily edit the rows containing a free TEXT field
- Temporarily edit the Increase Function parameters

ATTENTION: the free text in a row and the 'Increase' function parameters can be edited, but the modifications are not saved.

ATTENTION: T[xx] tokens cannot be edited at this stage. Go back to the User Model Editor to change rows with Tokens.

ATTENTION: in the case of engravings created in an OEM job queue, many of the parameters listed above cannot be edited as the indications provided by the manufacturer must be observed.

B - Tap 'QUEUE OF JOB' with the ENGRAVING function enabled to produce:

Add a job to the queue

Select the type of job:

Cut Engraving

Model CS62 TEST

Clamp 01R-01E-02E

Cutter 18DW

Flat side 2

Engraving depth 10

Rows of text ↑ Front

1 SILCA

2 Italy

SILCA
Italy

OK CANCEL

This screen is used to place either cuts or engraving in the queue, according to whether the user ticks the "Cut" and/or "Engraving" fields.

Further details are described in the section above.

2) Tap 'ENGRAVING' from the USER MODEL EDITOR.

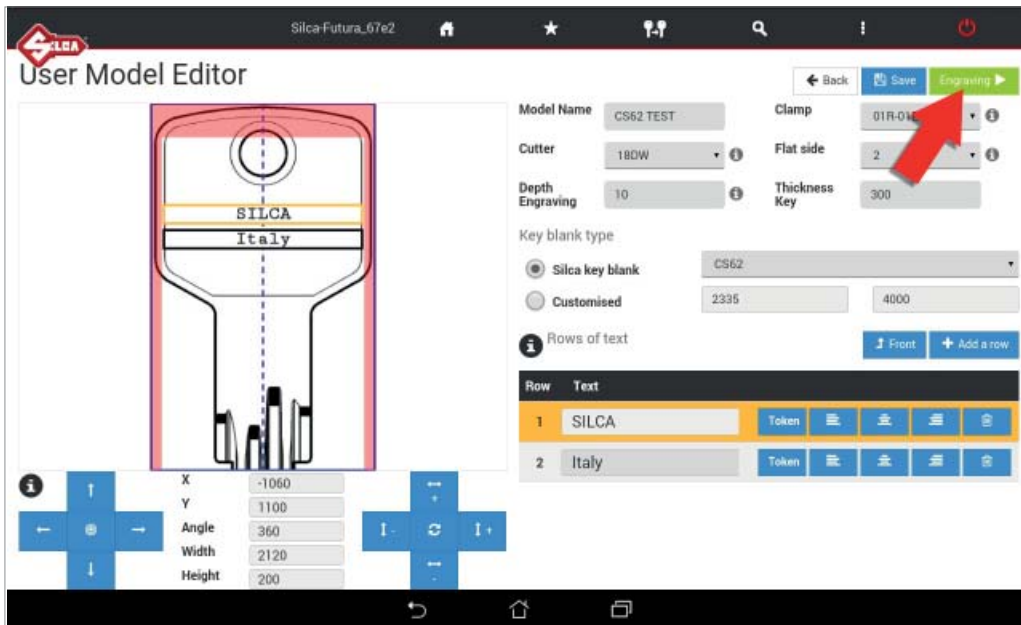

3) From JOB QUEUE

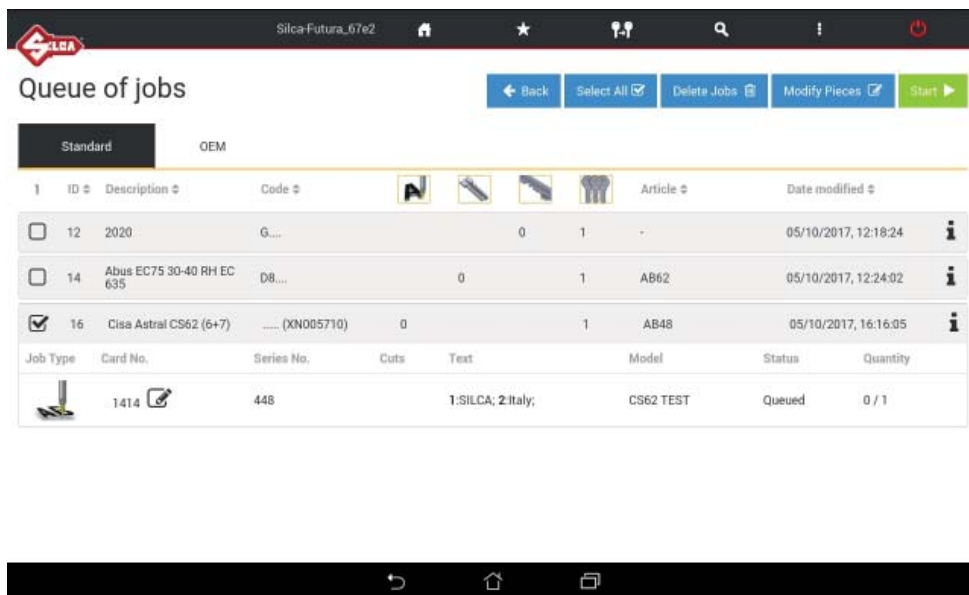

Further details are described in the section above.

7 OPTIONS



Options contains the following menus:

- **Info**
- **Calibration**
- **Settings**
- **Machine maintenance**
- **Upgrades**
- **Backup/Restore**
- **User series**
- **Code Maker (optional - see ch.11)**

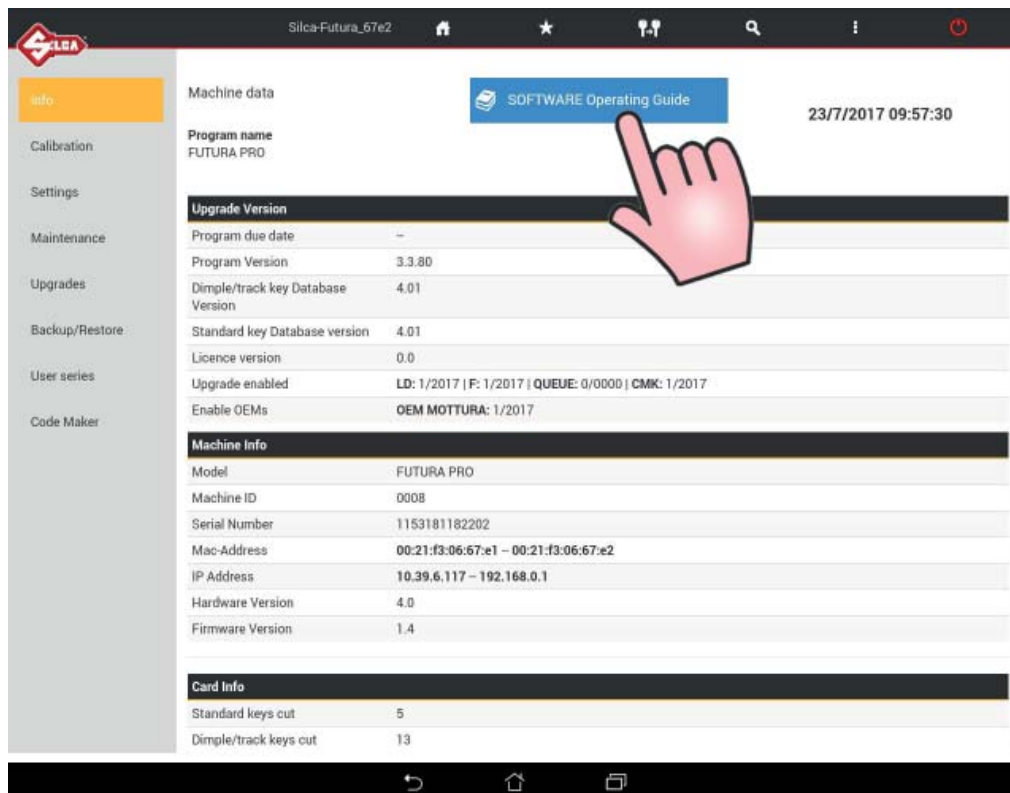

7.1 INFO

This window shows the main data for the Futura / Futura Pro machine (e.g. SW update version, serial number, number of keys cut, etc.).

Tap the appropriate icon to view the FUTURA PRO “SOFTWARE Operating Manual”.

ATTENTION: this function is not available for FUTURA.

7.2 CALIBRATION

Calibration includes:

- **Clamp Standard keys**
- **Clamps Dimple/Track keys**
- **Mobile Tracer**
- **Standard key Adapter**
- **Dimple/Track key Adapter**

7.2.1 STANDARD key clamp calibration

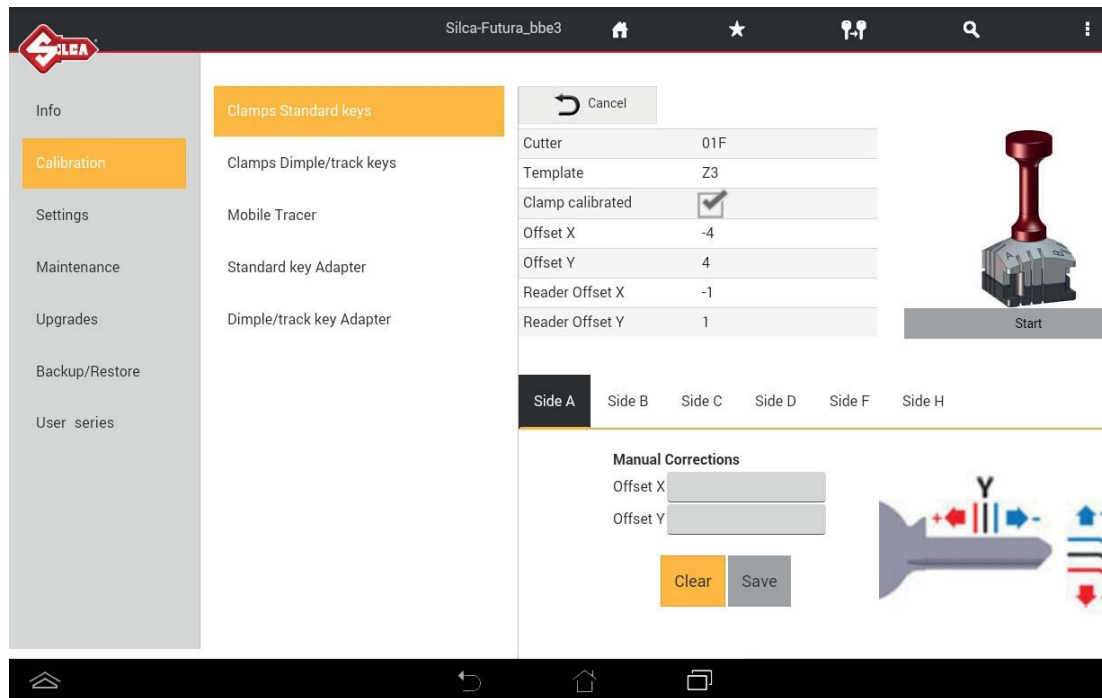

Tap START to begin calibration.
Fit template Z3 into the 01V clamp, as illustrated.

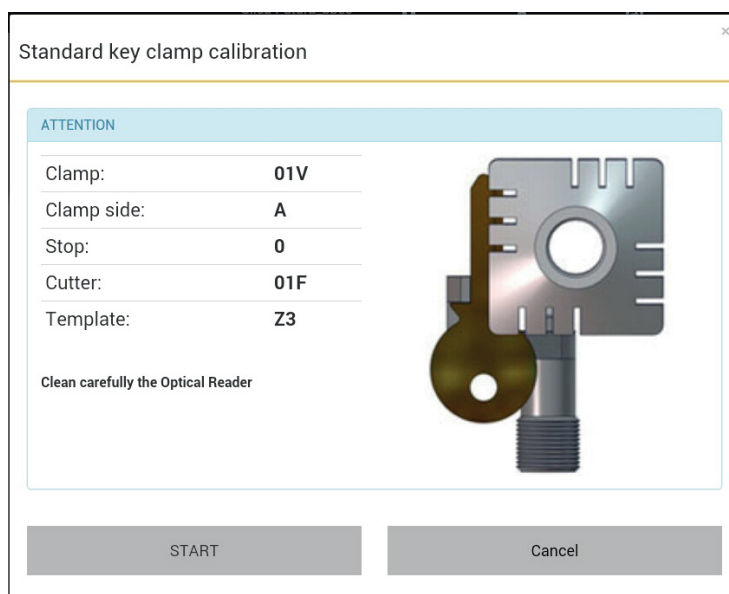

When the message “Clean carefully the Optic Reader and key without removing it” appears, lift the safety shield and carry out the required operations.

Close the safety shield and press START to continue.

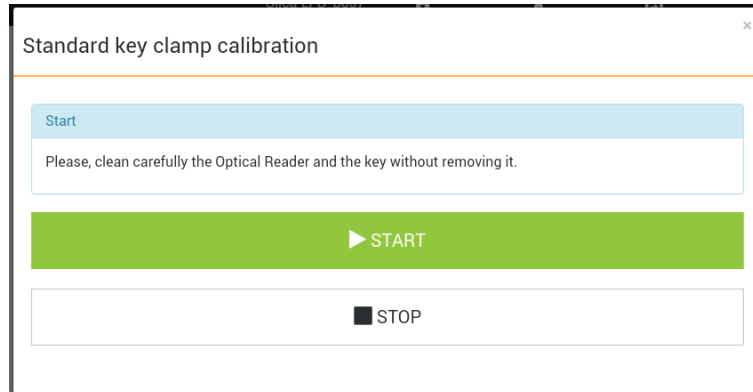

At the end of the operation you are required to save the data entered.

Tap “Yes” to confirm.

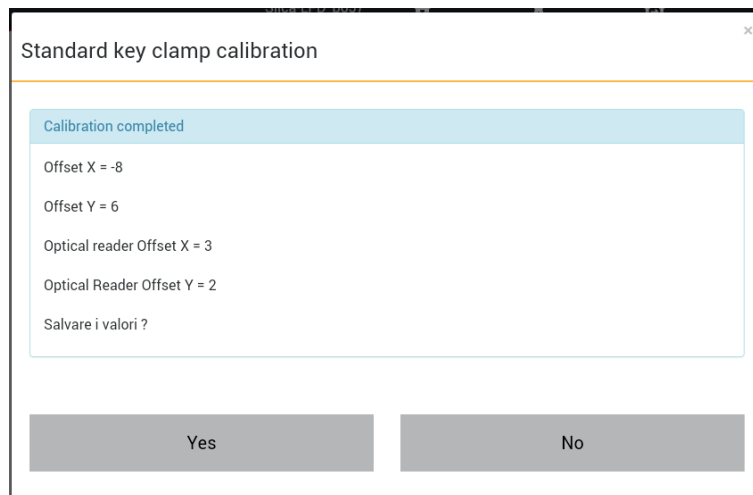

The 01V clamp is calibrated only for Side A.

Only Manual corrections of Y (spaces) e X (depth) can be entered on sides B, C and D.

Positive value of Y: takes cut closer to stop.

Negative value of Y: takes cut away from stop.

Positive value of X: lowers the cut from the axis.

Negative value of X: raises the cut from the axis.

Adjustments: from -30 to +30 hundredths of mm (+/- 118 thousandths of an inch).

Tap “Save” to confirm.

7.2.2 DIMPLE/TRACK keys clamp calibration

This menu contains a list of standard clamps and options for cutting these types of keys. Select the required clamp and tap START to begin calibration.

Use the 02T tracer for calibrating the clamps.

ATTENTION: to calibrate clamps with J... jaws make sure the jaws are closed completely before proceeding.

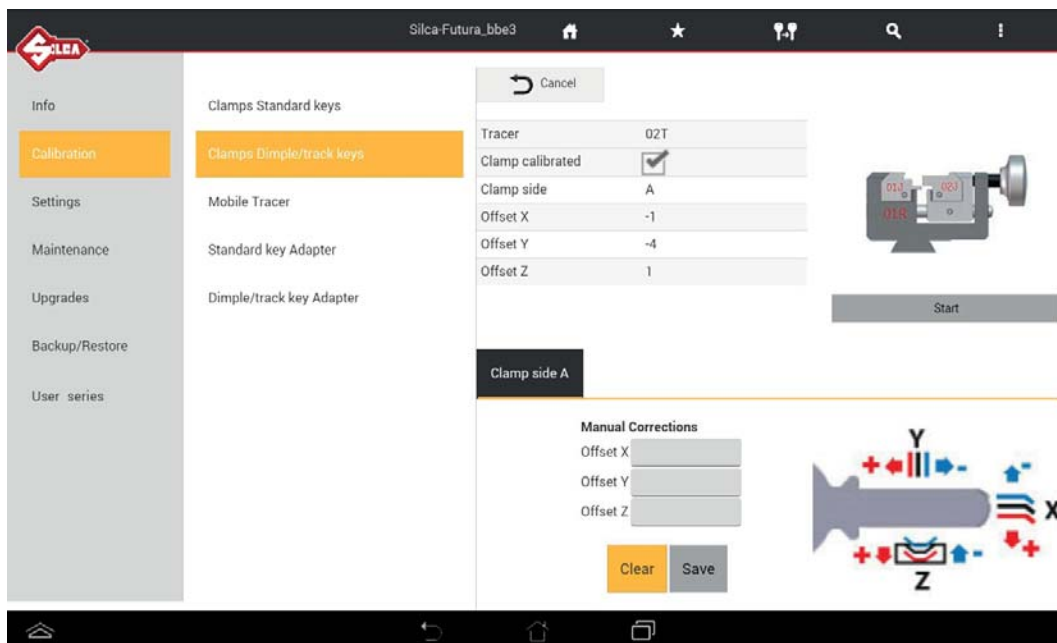
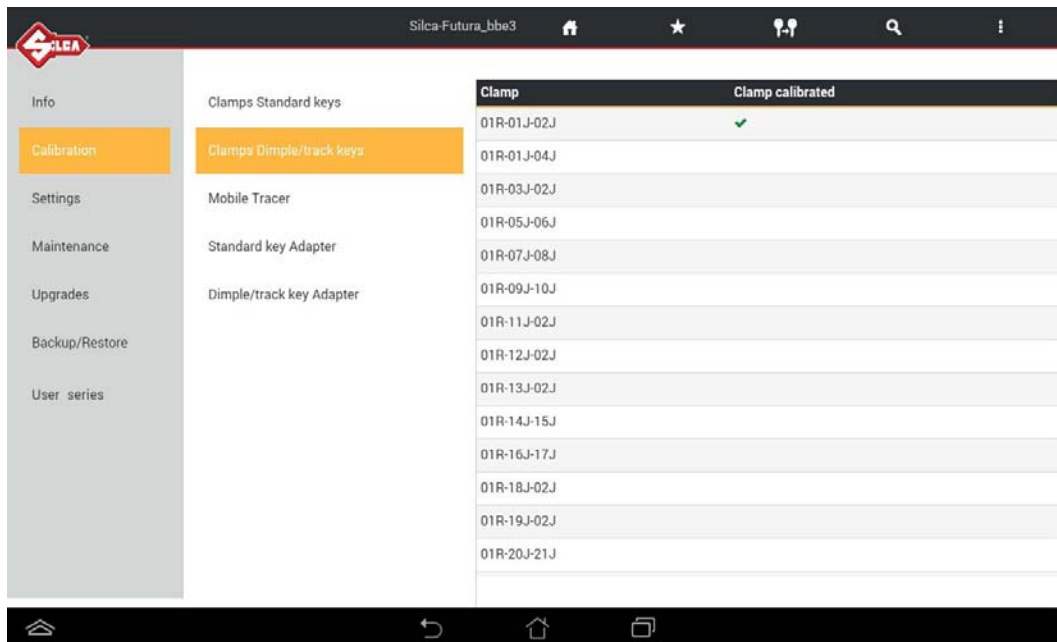

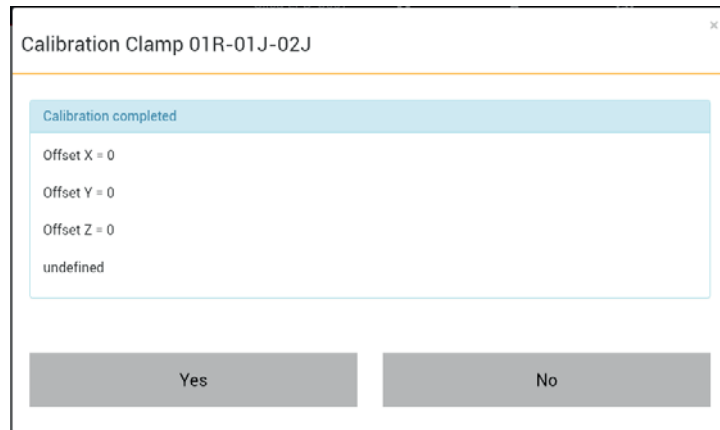

At the end of the operation you are required to save the data entered. Tap “Yes” to confirm.

MANUAL CORRECTIONS

Y, X and Z axis manual corrections can be applied if necessary.

Positive value of Y: takes cut closer to stop.

Negative value of Y: takes cut away from stop.

Positive value of X: moves cut to the right of the axis.

Negative value of X: moves cut to the left of the axis.

Positive value of Z: lowers the cut from the axis.

Negative value of Z: raises the cut from the axis.

Adjustments: from -30 to +30 hundredths of mm (+/- 118 thousandths of an inch)

Tap “Save” to confirm.

7.2.3 MOBILE TRACER 01T calibration

ATTENTION: when calibrating the 01T mobile tracer make sure the 01J-02J jaws are completely closed before proceeding.

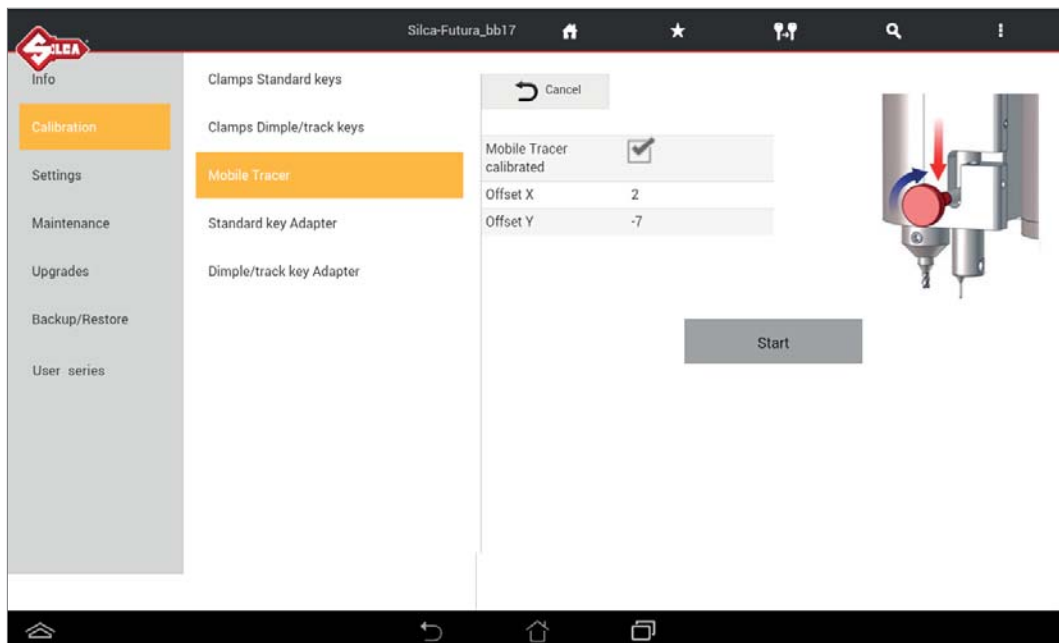

- Lower the 01T mobile tracer and lock in place by turning the knurled knob clockwise.
- Tap START to begin calibration and follow the instructions on the screen.
- At the end of the operation you are required to save the data entered.
- Tap YES to confirm.

7.2.4 STANDARD key Adapter calibration

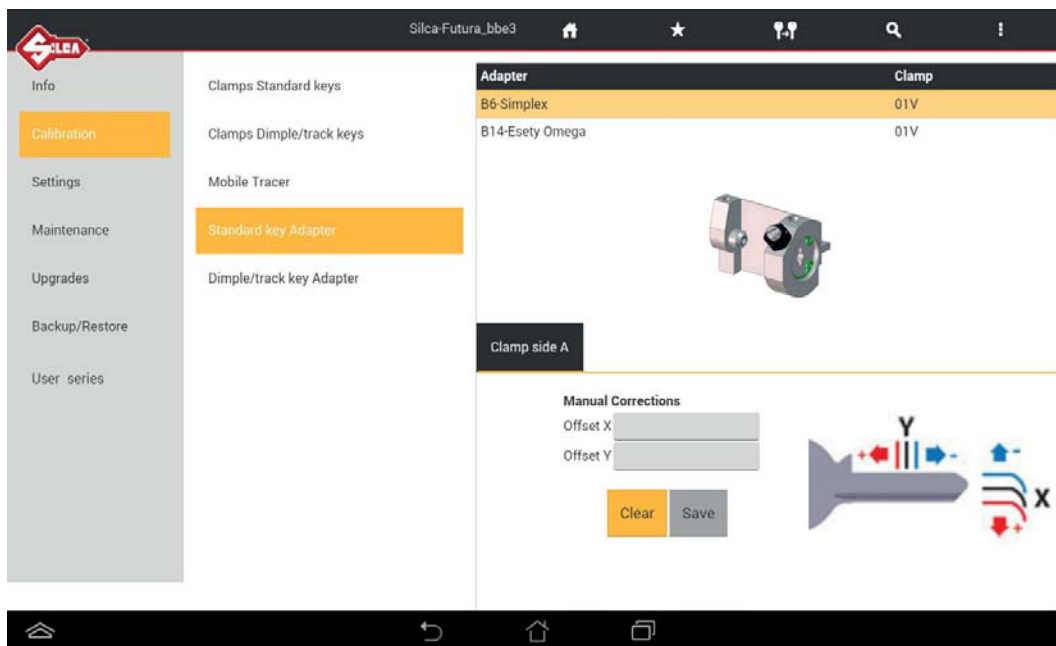

Adjustments to X (spaces) and Y (depths) can be made manually.

Positive value of Y: takes cut closer to stop.

Negative value of Y: takes cut away from stop.

Positive value of X: lowers the cut from the axis.

Negative value of X: raises the cut from the axis.

Adjustments: from -30 to +30 hundredths of mm (+/- 118 thousandths of an inch). Tap "Save" to confirm.

7.2.5 DIMPLE/TRACK keys Adapters calibration

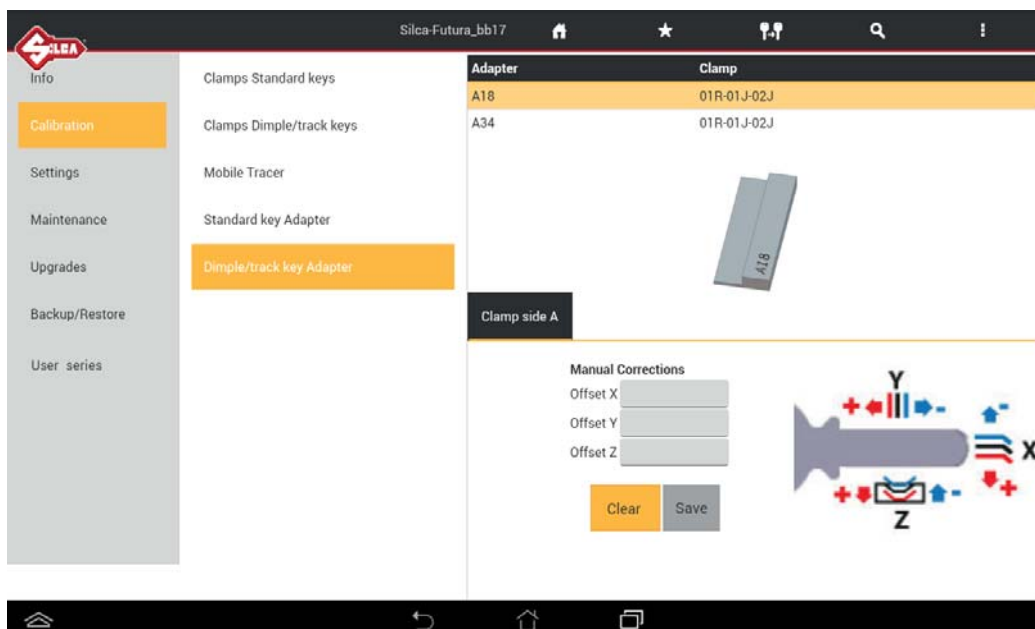

Positive value of Y: takes cut closer to stop.

Negative value of Y: takes cut away from stop.

Positive value of X: moves cut to the right of the axis.

Negative value of X: moves cut to the left of the axis.

Positive value of Z: lowers the cut from the axis.

Negative value of Z: raises the cut from the axis.

Adjustments: from -30 to +30 hundredths of mm (+/- 118 thousandths of an inch). Tap "Save" to confirm.

7.3 SETTINGS

The Settings menu contains:

- **Zero-point Calibration (STANDARD key)**
- **Zero-point Calibration (DIMPLE/TRACK key)**
- **Options**
- **Network setting**

7.3.1 Zero-point Calibration (STANDARD key)

Tap START and follow the instructions on the screen.

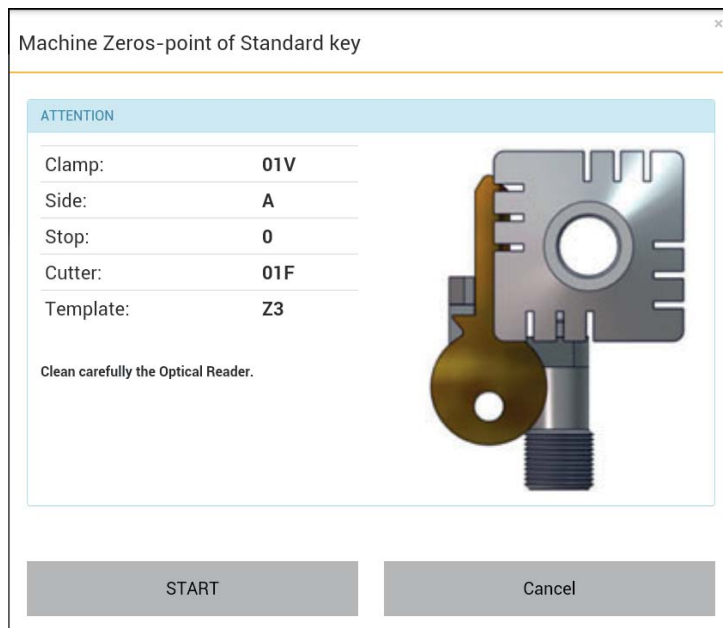
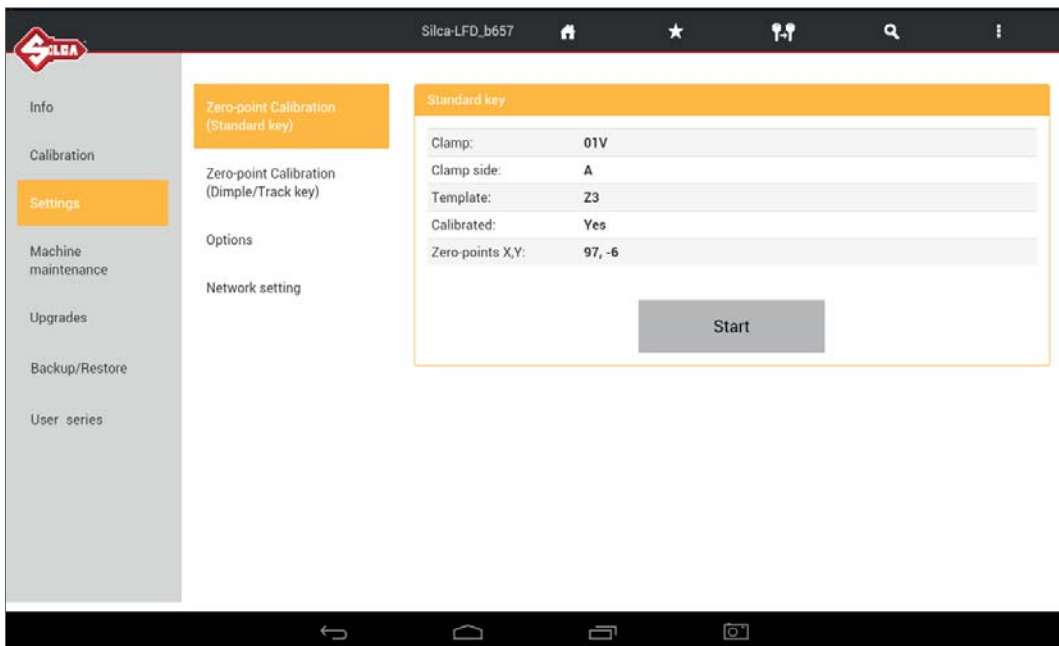

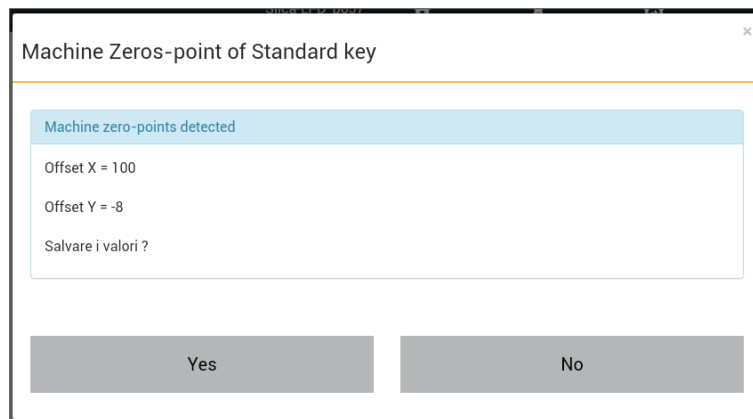
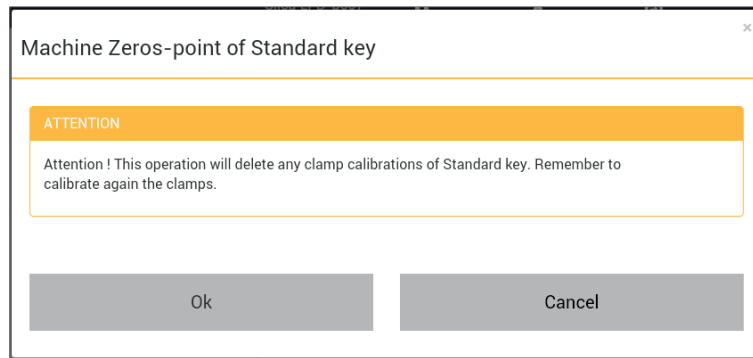

At the end of the operation you are required to save the data entered.
Tap "Yes" to confirm.

7.3.2 Zero-point Calibration (DIMPLE/TRACK key)

This operation requires the use of the 02T tracer.

ATTENTION: make sure the jaws are completely closed before starting.

Tap START and follow the instructions on the screen.

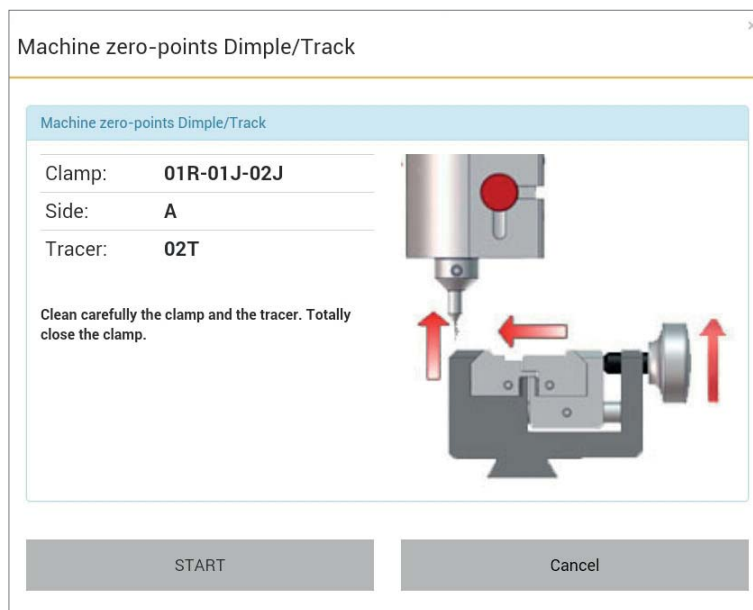
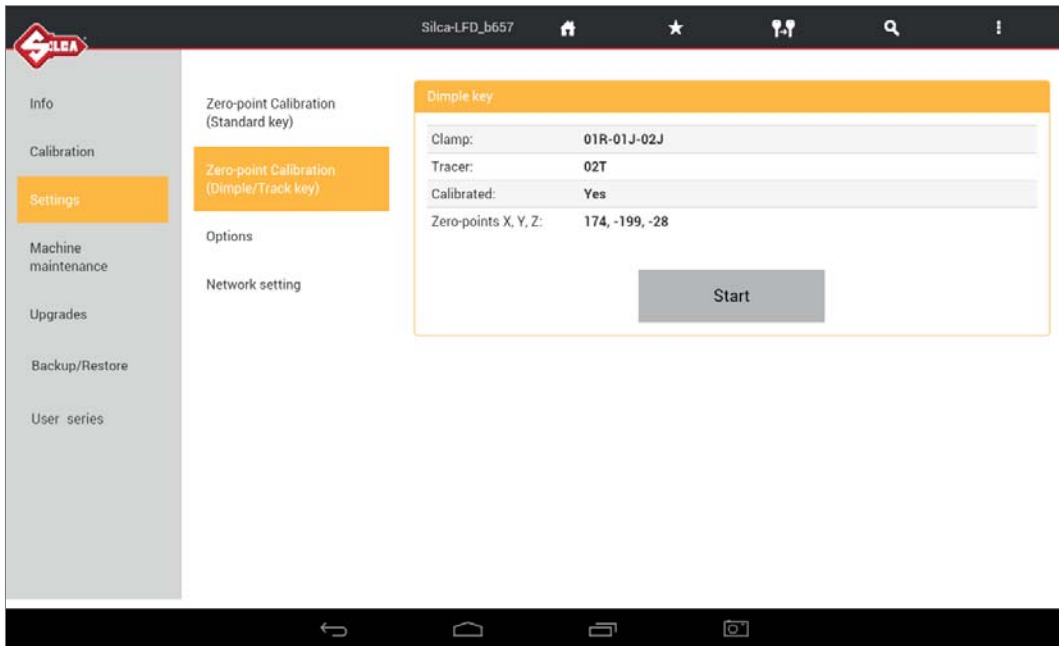

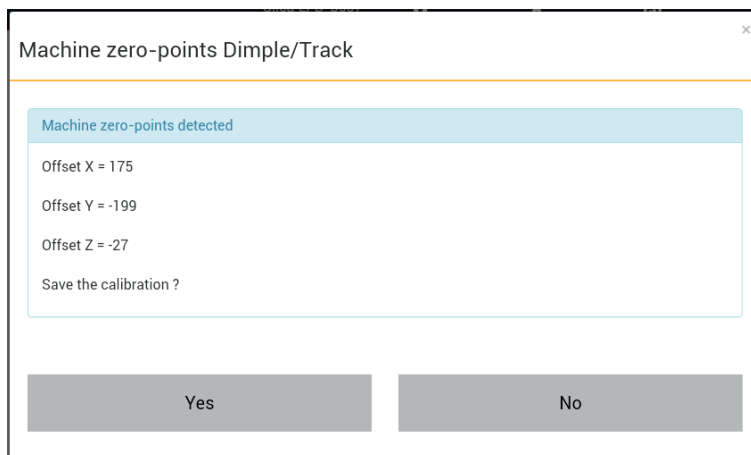
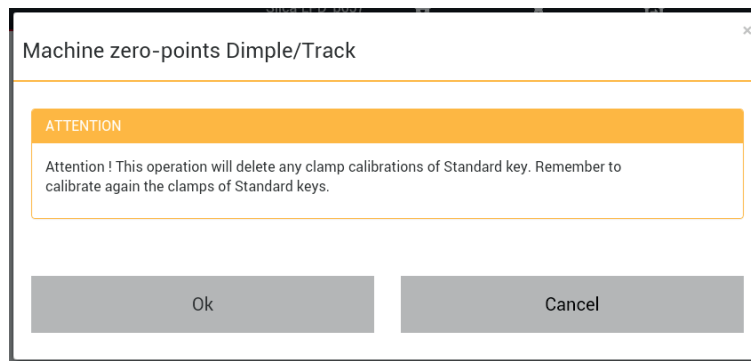

At the end of the operation you are required to save the data entered.

Tap "Yes" to confirm.

NOTE: Remember to replace the 02T tracer with the proper cutter prior to attempting to cut a key to prevent damaging the 02T tracer.

7.3.3 Options

The Options menu contains:

- **General**
- **Preferences STANDARD key**
- **Preferences DIMPLE/TRACK key**

7.3.3.a General

The following parameters can be modified:

- **Measurement Unit** (millimeters or inches)

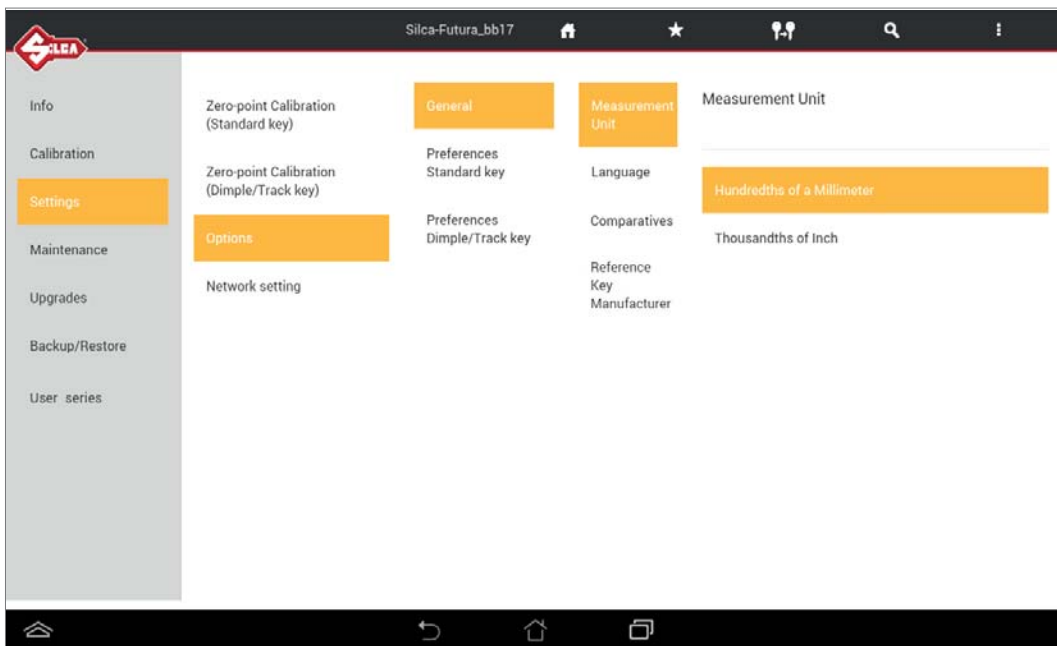

- **Language**

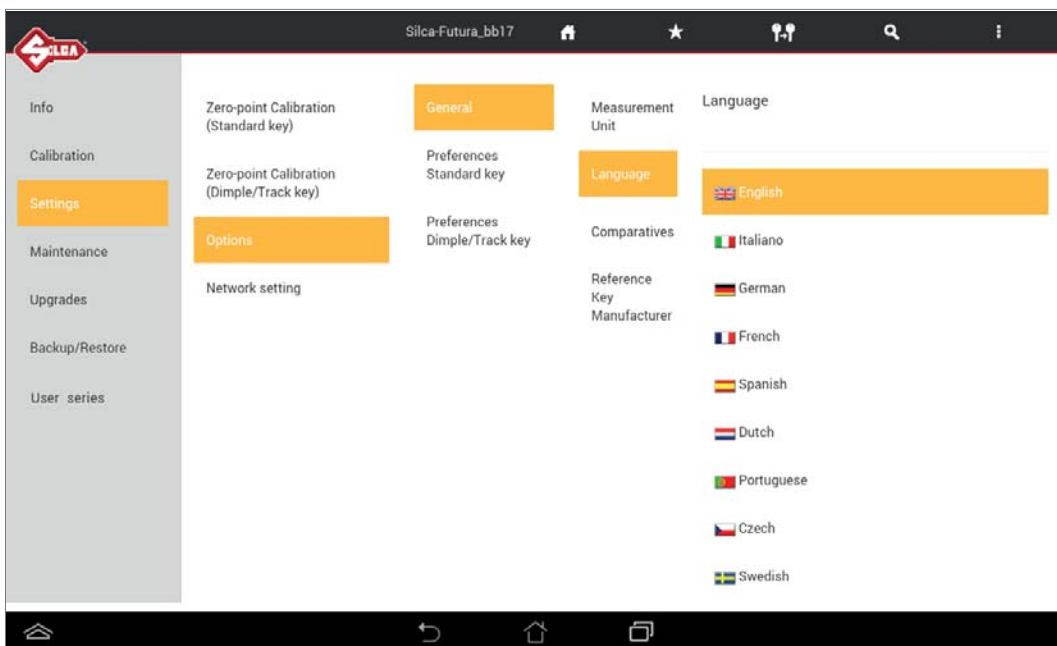

- **Comparatives** (comparative brands to visualize for key research)

It's possible to pick and/or unpick brands that can be seen after a research of comparatives articles. In the comparative list Silca is activated by default.

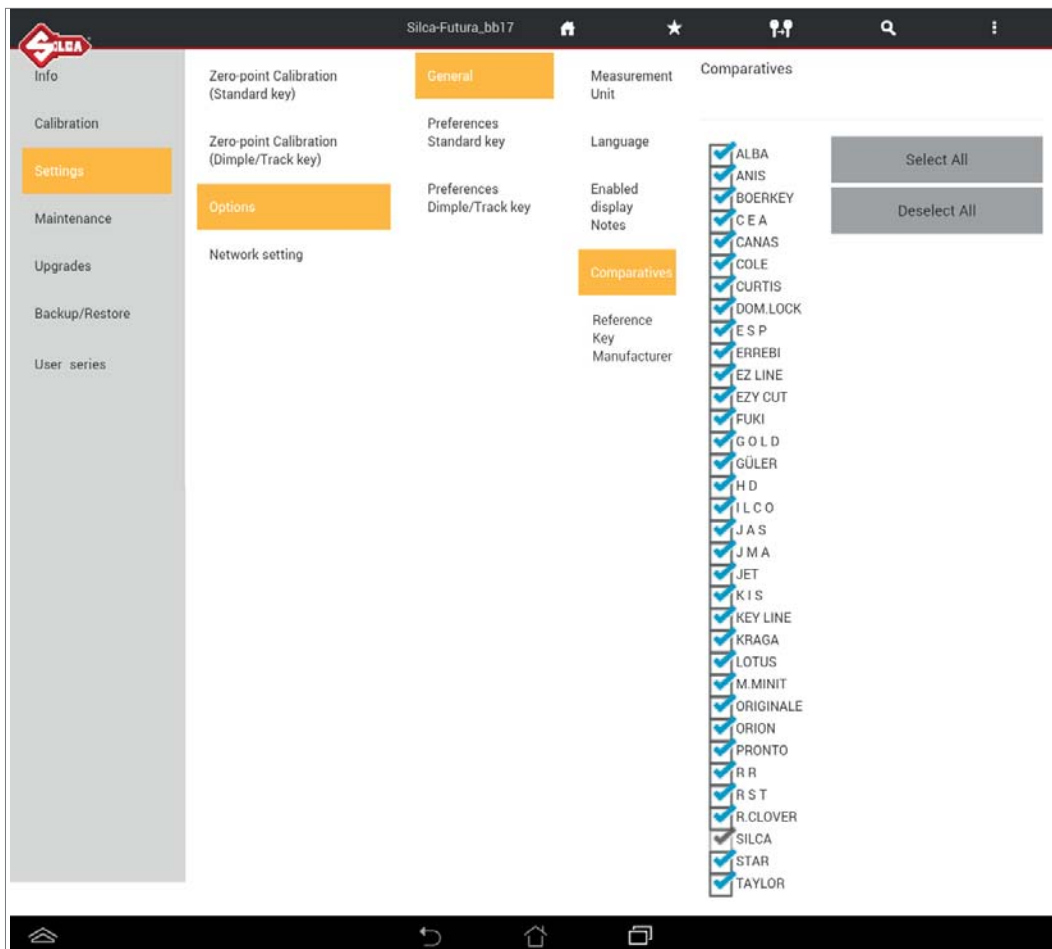

- **Reference Key Manufacturer**

After a key search... the key to be duplicated will always (with exception*) be the Silca reference by default. ILCO can also be set as a reference by default.

* keys that are not produced by Silca (copyright - obsolete - new keys)

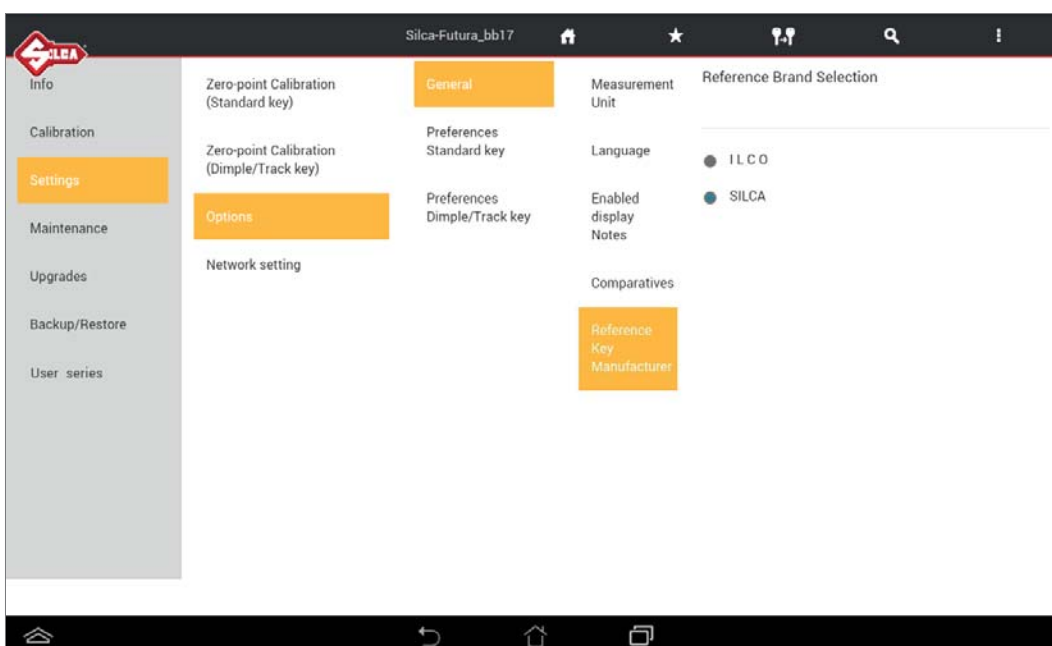

7.3.3.b Preferences STANDARD key

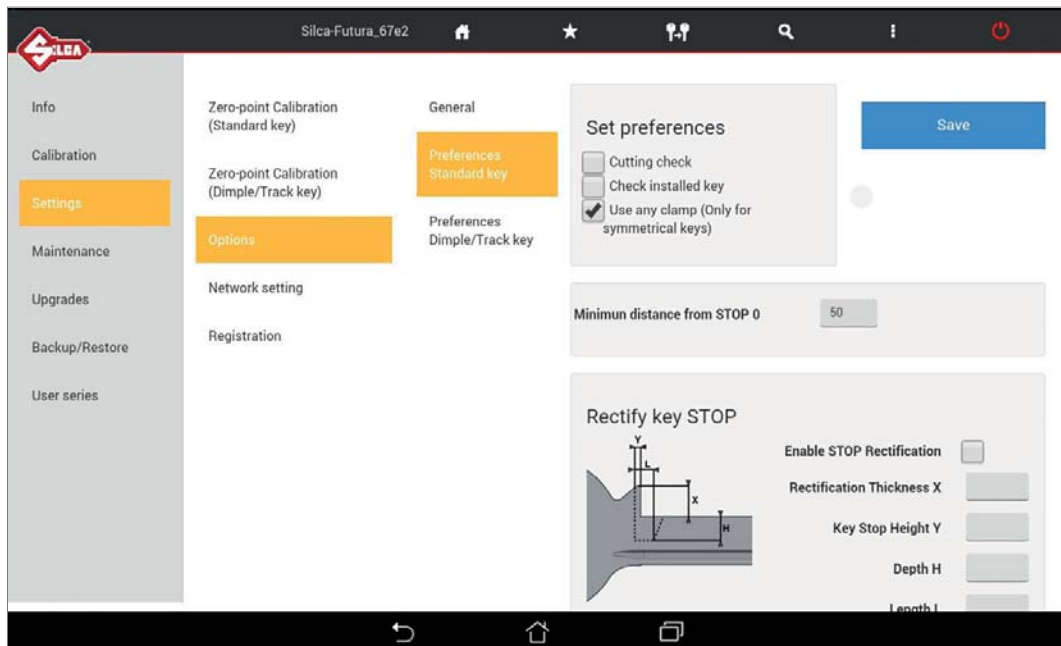

Cutting check: in simple terms ...MACS protection (Maximum Adjacent Cut Specification). When enabled this function prevents the machine from accepting user input of direct cuts that would result in a combination of cuts not included in the data cards.

Check installed key: when enabled this function checks whether the second side of the key is properly aligned in the clamp. Any alignment errors (taper) will be offset. This function is used only for keys with cuts on both sides.

Use any clamp: if this function is enabled the key to be cut can be positioned on a clamp side different from default. The function is used to acquire the measurement of the key blank (stem width) in order to adapt cuts to the key blank being used. It is applied automatically only to keys with double symmetrical sides.

ATTENTION: option valid for **CUTTING** only (**NOT DECODING**).

Rectify key STOP: when enabled adjusts the key stop as per instructions on the screen.

Minimum distance from stop: the range [50-90] (hundredths of a millimeter); 197-354 thousandths of an Inch)

Interval for parameters involved (in hundredths of a millimeter):

| | |
|---|---------|
| X | 0 - 99 |
| Y | 0 - 400 |
| H | 0 - 400 |
| L | 0 - 500 |

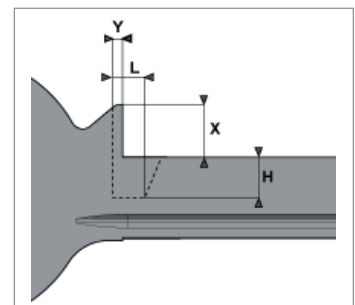

7.3.3.c Preferences DIMPLE/TRACK key

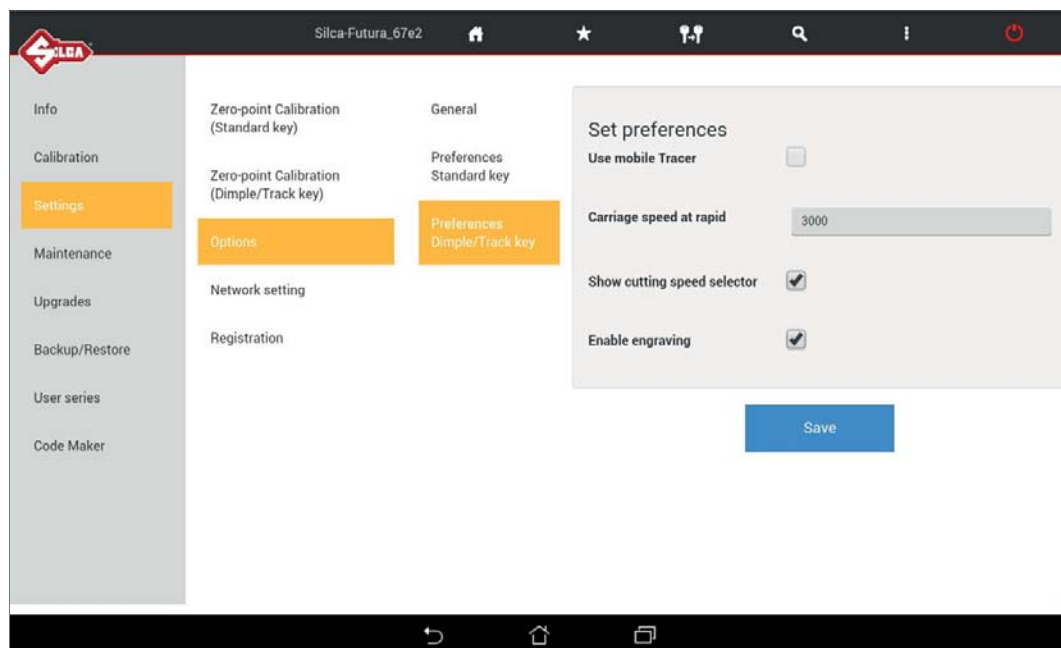

Set preferences: used to enable or disable the use of the 01T mobile tracer. If the field is not selected the 02T tracer is required, to be fitted into the shaft for the decoding operations.

Carriage speed at rapid: used to set the carriage speed for rapid movements; the pre-set value of 3000 is recommended by Silca.

Enable engraving: used to enable the ENGRAVING function wherever required, at any point in the program.

7.3.4 USE

The machine can be set up in one of the 4 modes below:

- 1) **ACCESS POINT** through Wi-Fi (factory configuration)
- 2) **ETHERNET** with connection to LAN and router (to connect the machine to the internet)
- 3) **TETHERING USB** (for connecting tablet and machine via cable)
- 4) **LOCAL NETWORK (LAN)** (to connect the machine to the internet)

| MODE | ACCESS TO INTERNET | TABLET - MACHINE Connection  | Recommended |
|---------------------------------|--------------------|---|-------------|
| ACCESS POINT | NO | Wi-Fi | YES |
| ETHERNET with connection to LAN | YES via CABLE | Wi-Fi | YES |
| TETHERING USB | NO | USB cable | YES |
| LOCAL NETWORK | YES via Wi-Fi | Wi-Fi | - |

7.3.4.a ACCESS POINT mode (Wi-Fi connection between machine and Tablet)

In this mode the Tablet connects directly to the machine.
The machine is set on this mode in our workshops.



Fig. 10

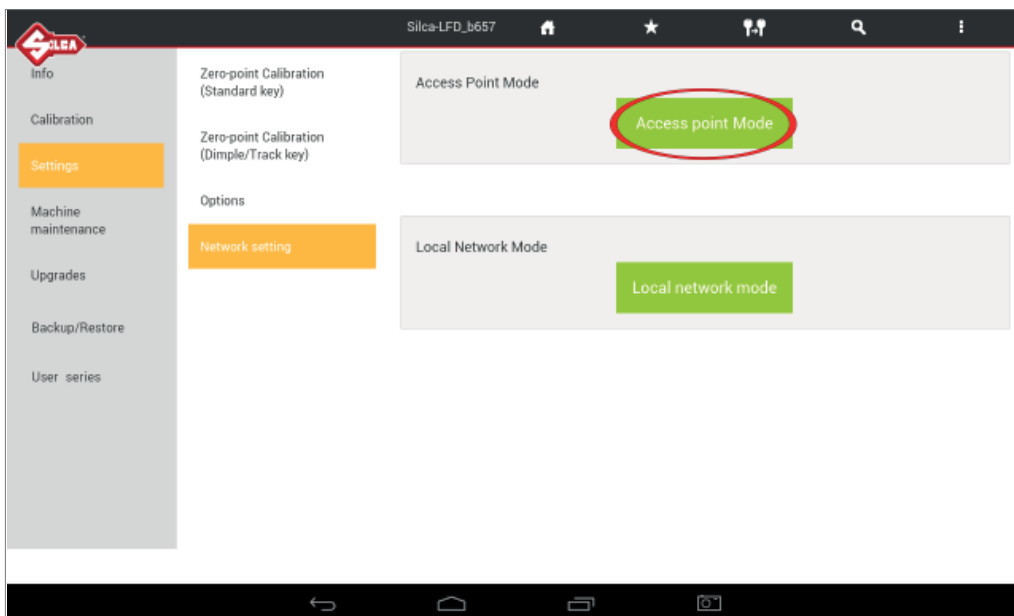

When the machine and Tablet are switched on the connection automatically activates in around two minutes; if not, check the Wi-Fi connection from your Tablet to see if the machine is included in the Wi-Fi networks that are found; the machine will appear as **Silca-Futura_....**

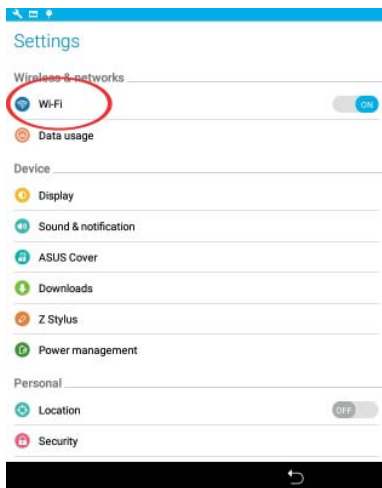

If it is not connected pick “Silca-Futura_...” and input the password which correspond to the machine serial number (made up of 13 numbers).

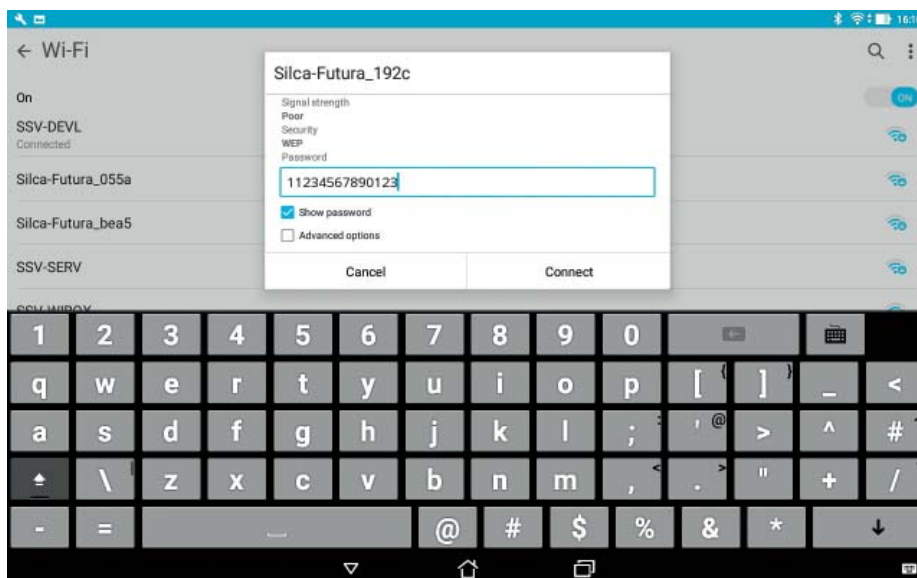

The option to change the Wi-Fi channel is used in cases when the (point to point) communication cannot be properly connected since there are too many devices tuned to the same channel. It also permits the user to adapt to the rules and restrictions of Wi-Fi channel use in their country. To change the channel one must first be connected, select the new channel and then reboot the machine.

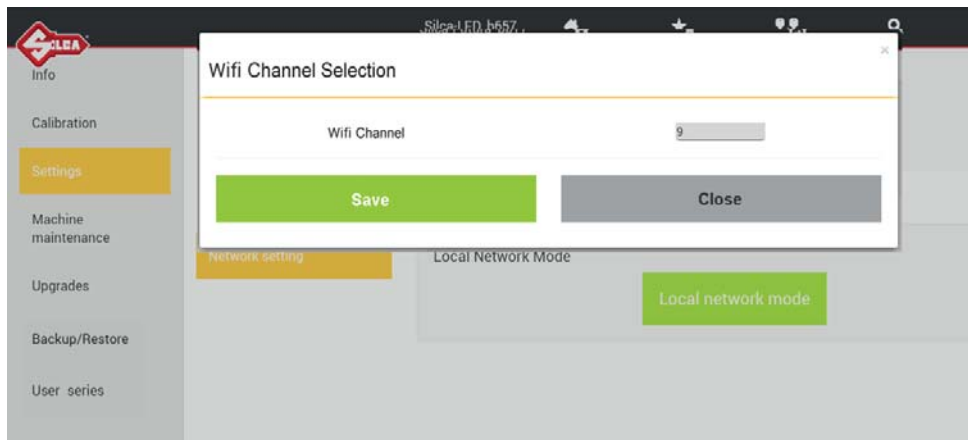

7.3.4.b ETHERNET with connection to LAN and router

To connect the Futura / Futura Pro machine to the internet through your LAN:

- Set the machine on ACCESS POINT and connect the tablet in Wi-Fi to the machine (factory configuration).
- Connect your LAN ethernet cable to the machine (Fig. 11).

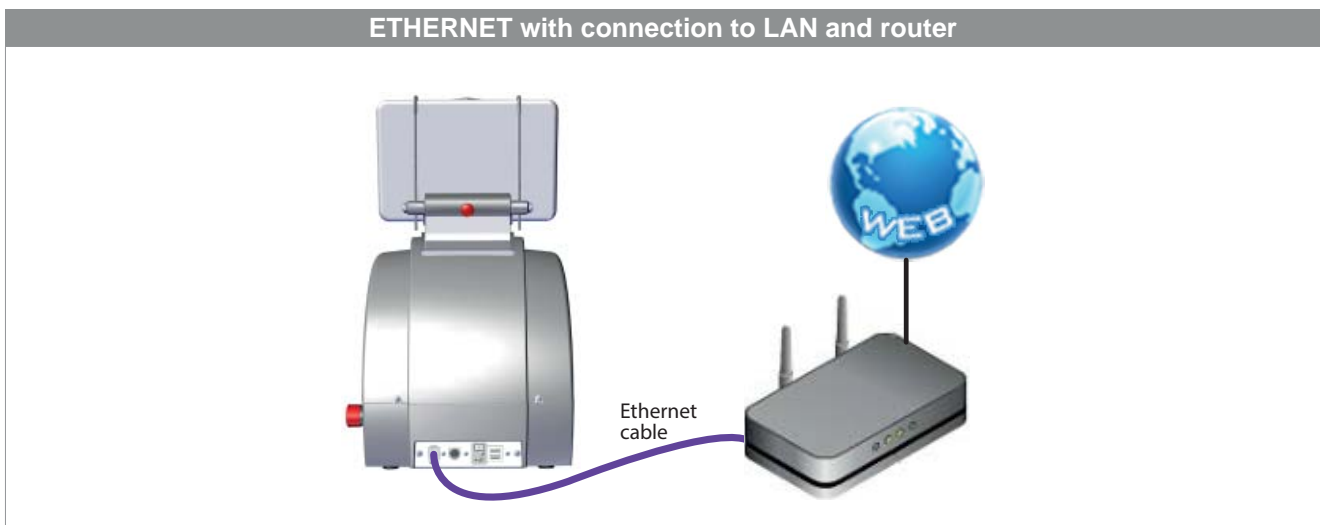

Fig. 11

7.3.4.c TETHERING USB mode

This method is used to connect the machine to a Tablet by means of a USB cable. Use the power cable provided with the Tablet.

Attention! This control is active and can be selected only if:

- the Tablet Wi-Fi network is disabled (OFF).
- the USB cable is connected to the Tablet and machine (Fig. 12).
- an Ethernet cable is not connected to the machine port.

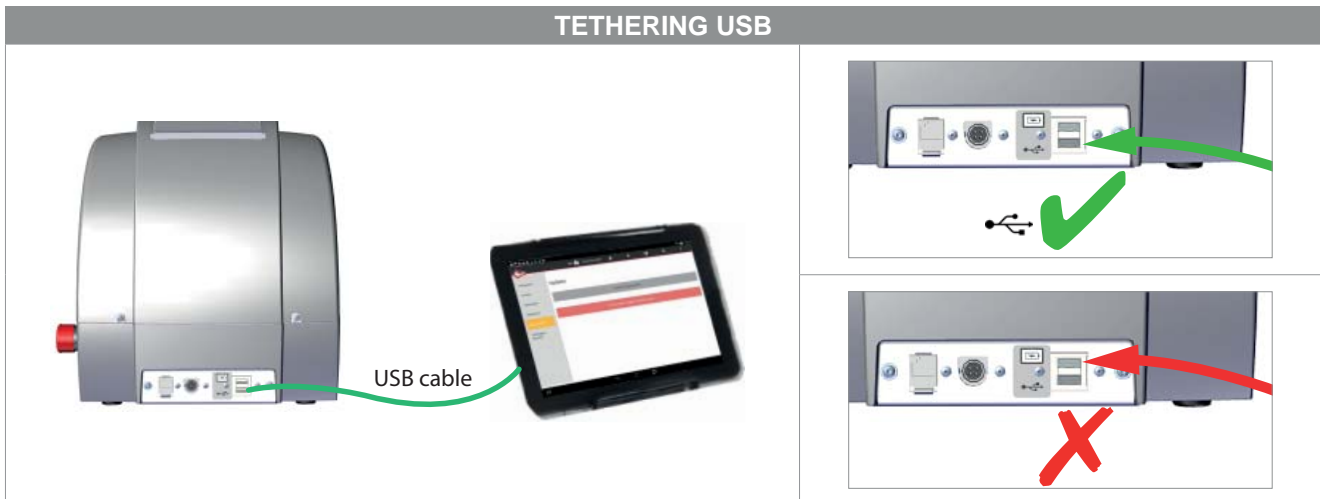

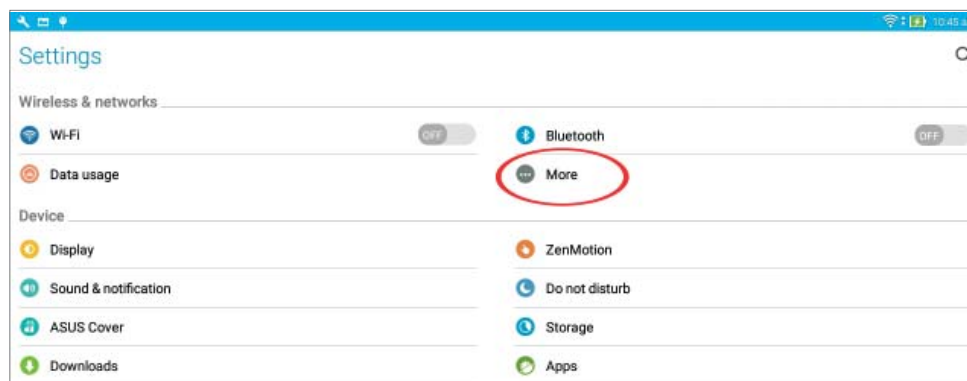

Fig. 12

- 1) Connect the USB cable to the machine and Tablet (Fig. 12). **Note: FUTURA has one USB port only.**
- 2) Access “Settings”  on the Tablet.
- 3) Set “OFF” to disable the Wi-Fi.
- 4) In the Tablet “Settings” tap the “More...” icon and select the item “Tethering & Portable hotspot”.



- 5) Tick “USB Tethering” or select “ON” to enable.

When this item is enabled a green light on the machine will flash for a few seconds. It may take 10-20 seconds for this to happen.

Start the Silca Futura APP and open the drop-down menu.
Select "Connect to" to find the machine.

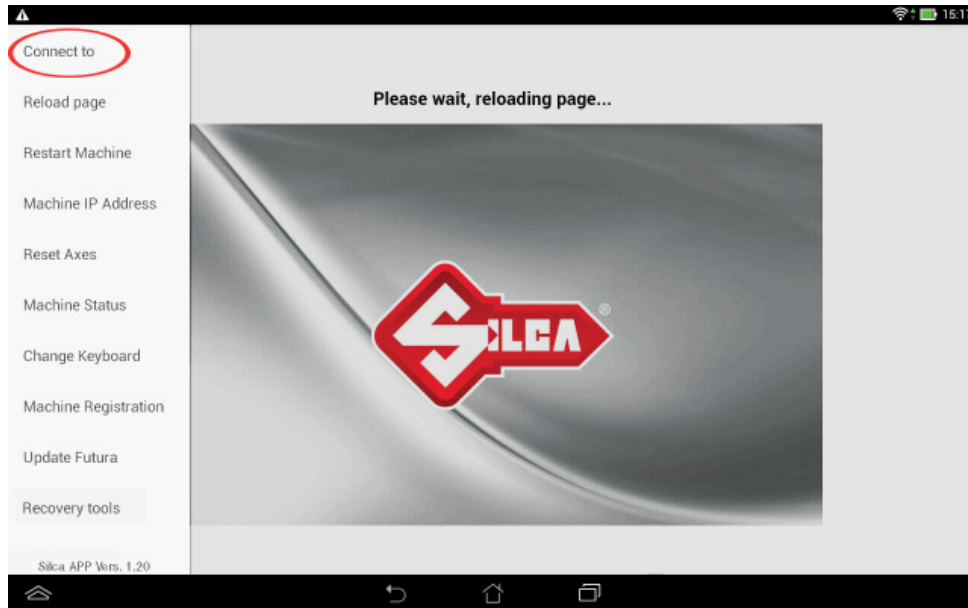

When the machine has been found, hit to select and establish connection.

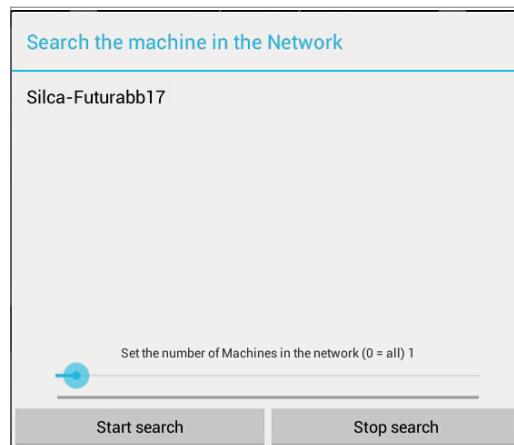

NOTE: if the Tablet and machine have been turned off, when turning on the USB connection must be made again, in the way described above, if you wish to work with the Tethering USB mode.

NOTE: when the machine-tablet connection has been made, if necessary you can re-boot the tablet Wi-Fi connection to connect to the internet.

7.3.4.d LOCAL NETWORK mode

This mode is useful to connect the tablet and machine, sharing the internet access provided by the router. If this is required we suggest in any case using the “Ethernet with connection to LAN” configuration, as described in Chapter 7.3.4.b as it performs better.



Fig. 13

To access this method of use, go to the Options > Settings menu, select “Network setting” and hit the LOCAL NETWORK mode icon.

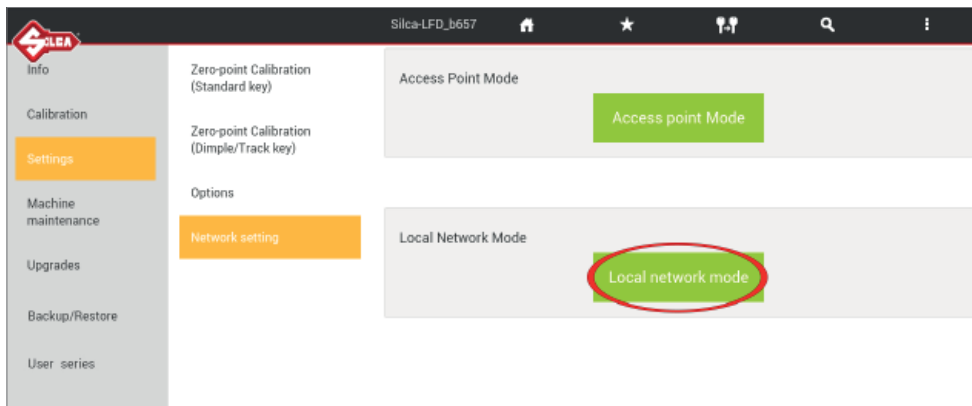

Perform the following operations to activate this method:

1) FUTURA / FUTURA PRO CONNECTION TO A WI-FI ROUTER

Pick the network to which you want to connect by tapping the SSID field and then inserting the network's password.

Tap "Save" to reboot the machine in Local Network. The machine should initially reboot with a flashing white and blue light, to then end with two flashing blue lights that indicate the connection to the local network was successful.

If the inserted password was incorrect the machine would reboot in ACCESS POINT mode with an intermitted flashing blue light.

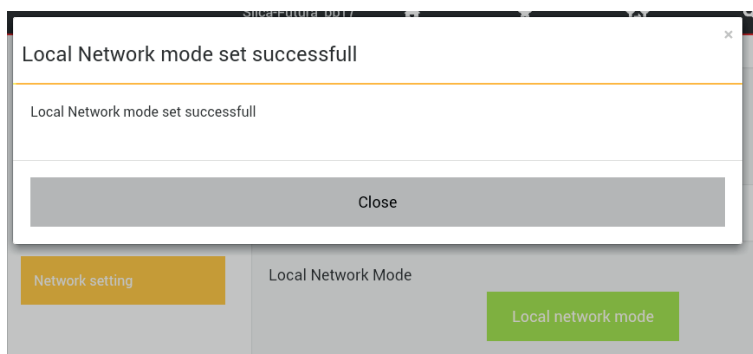
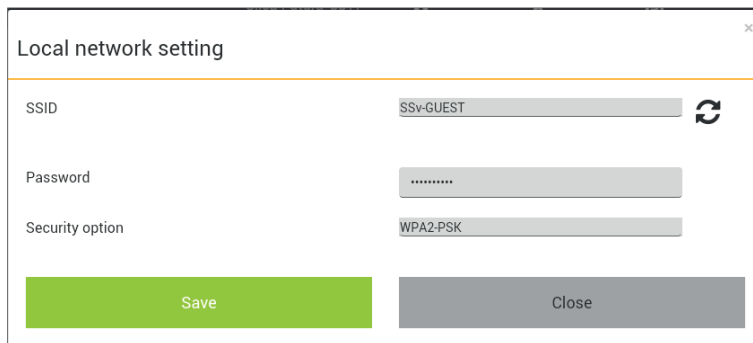
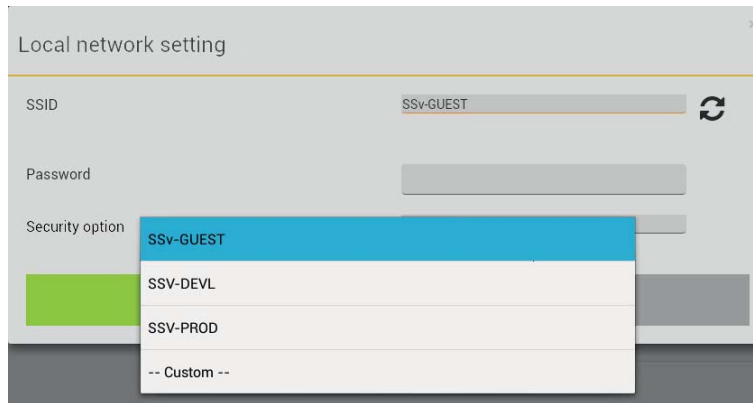

2) CONNECTING TABLET TO A WI-FI ROUTER

From the Tablet's "Settings" menu  tap on the desired network to connect.

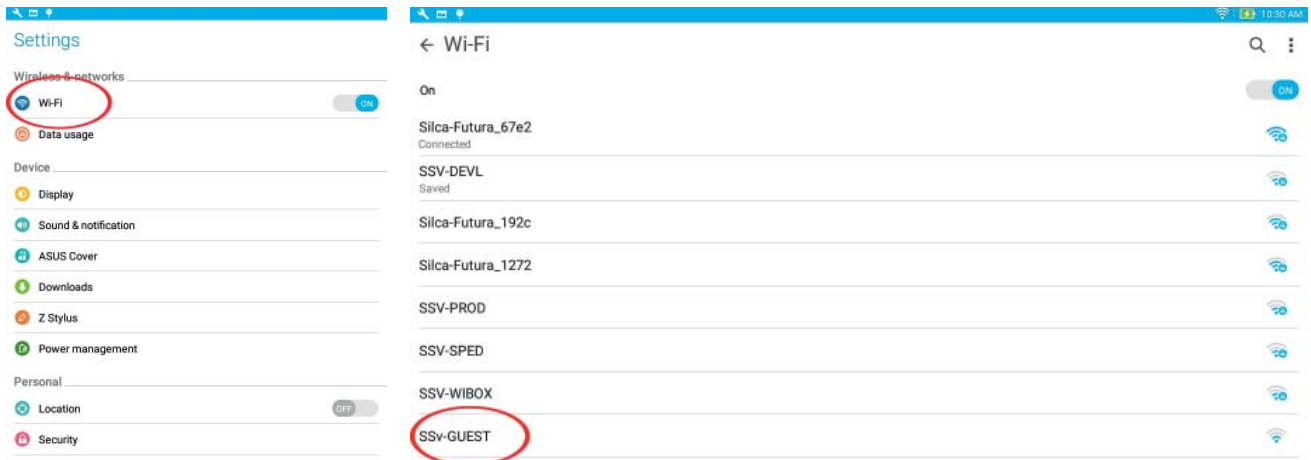

3) REBOOTING THE FUTURA'S APPS

Open the drop-down menu and select "Connect to".

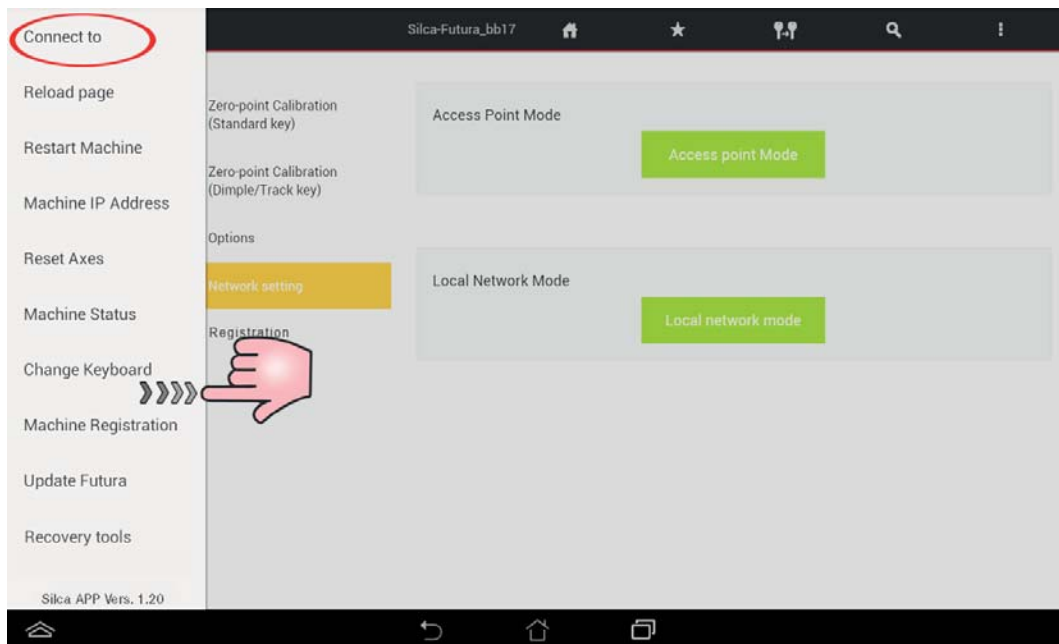

Tap on “Start Search” in the following window.

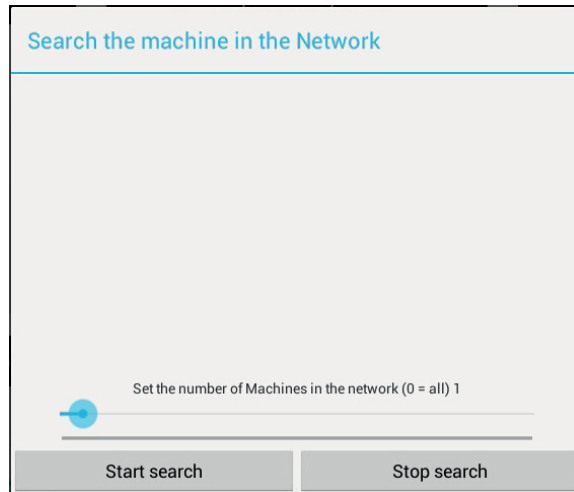

Tap on “Silca-Futura...” in the following window to obtain a connection between the Futura’s **APPS Silca.apk** and the machine.

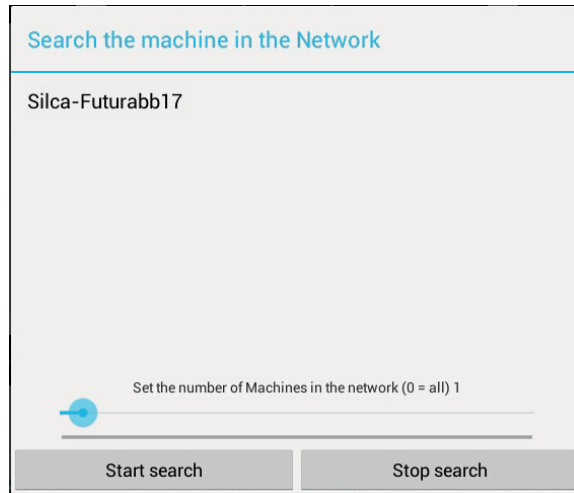

NOTE: the last mode setting will be automatically saved by the machine at each successive reboot; if the last set mode was LOCAL NETWORK and this mode is not recognized within a certain time frame the Futura / Futura Pro will automatically go to ACCESS POINT mode.

7.4 MACHINE MAINTENANCE

• Digital Inputs

This function is used to test operation of the digital inputs on the electronic board to which they are connected: screen micro, gauge position sensor, electrical contact, etc.

To perform the test carry out the movement described for each item and check that the relative signal changes color from red to green.

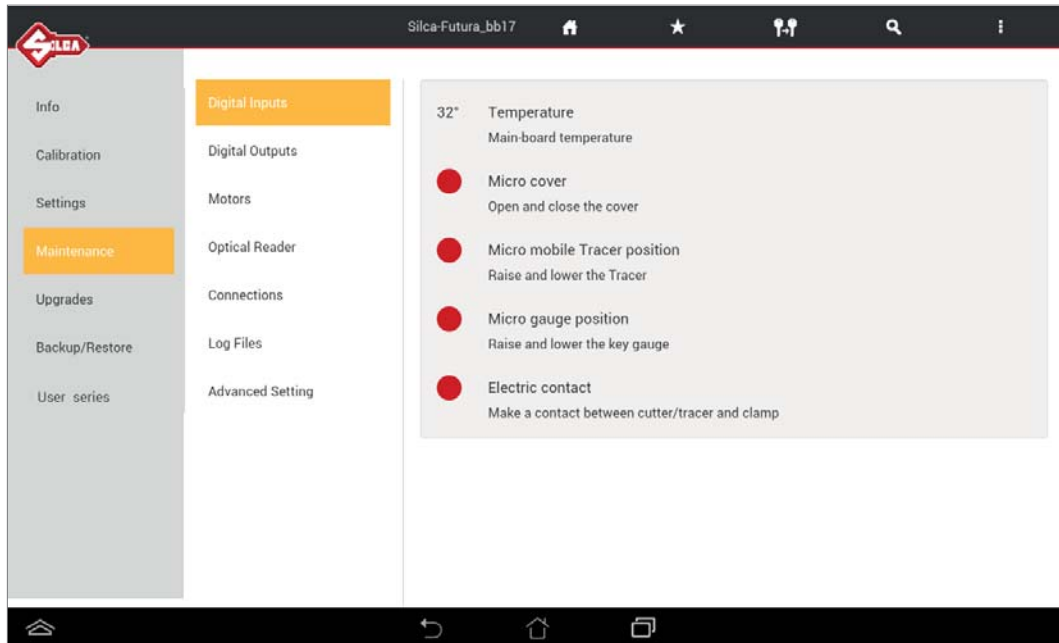

• Digital Outputs

This function is used to test operation of the digital outputs on the electronic board and relative devices connected to it. To perform the test tap ON on the screen.

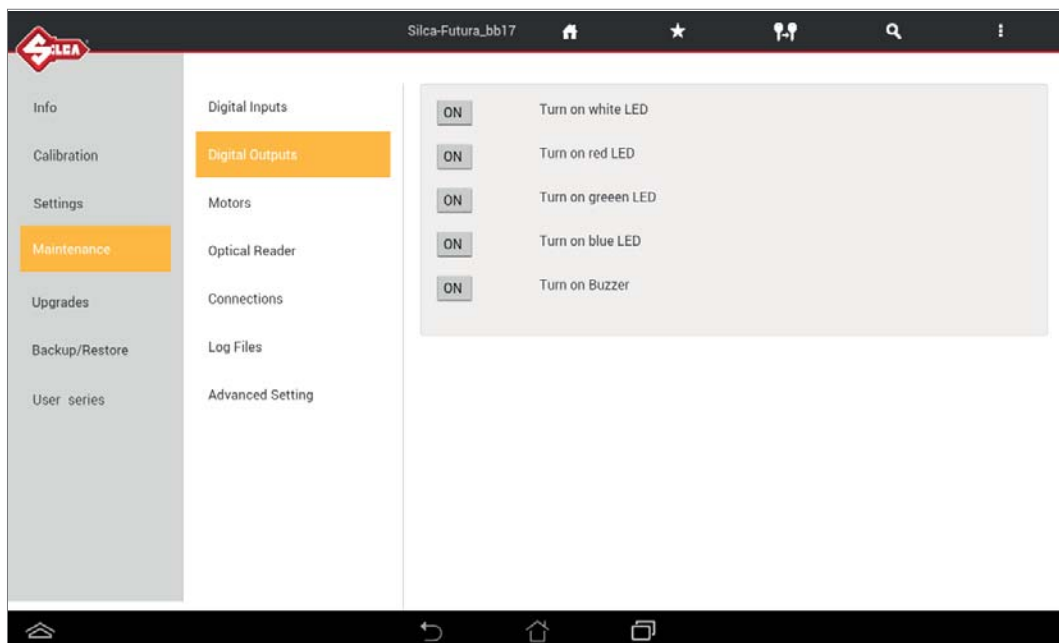

• **Motors**

This function is used to test operation of the 3 step motors for the X, Y and Z axes (at the moment the B axis is not used). To perform the test tap “+” for the axis involved.

Note: The carriage must not reach and hit the end of its run.

The Reset key homes the axes.

NOTE: tap “-” only when the value shown in the “Working position” field is positive.

Axis clearance sensor: the ring becomes green when activated.

• **Cutter motors**

To perform the test tap the button for the motor to be tested: check that the cutter turns for 5 seconds.

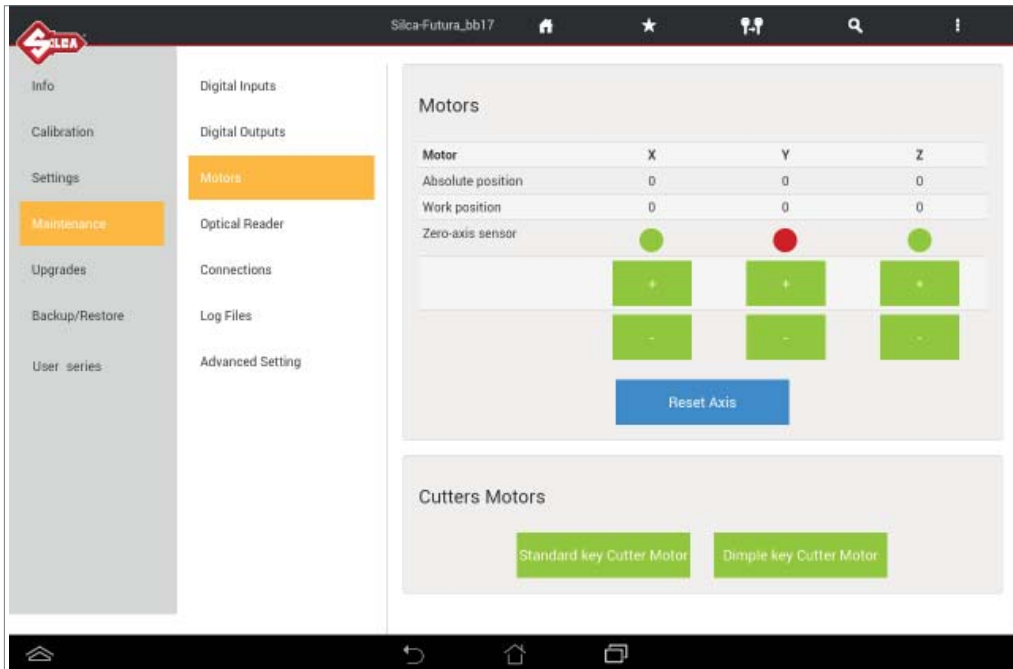

• **Optical Reader**

Perform the Optical reader threshold test to verify if the optical reader is active.

- Tapping on the “Read laser threshold” switches the optical reader from “-” to “0”.

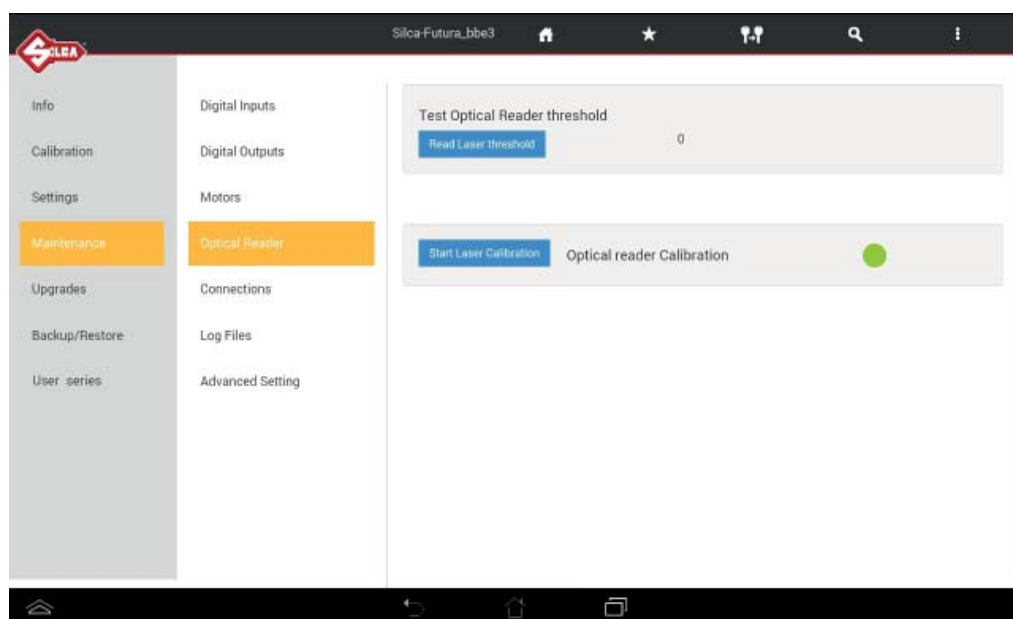

- Perform the Optical reader threshold test only if encountering anomalies when reading and/or decoding keys.
- Thoroughly clean the optical reader’s glass, close the protective shield.
- Tap on “Optical reader calibration”:
 - the green ball indicates that the optical reader is calibrated.
 - the red ball indicates that you must thoroughly clean the optical readers lens and re-calibrate the reader.

ATTENTION: after the Optical reader calibration proceed with the machine zero points calibration (standard flat keys) then with the standard flat keys clamp calibration.

• **Connections**

This function shows all the machine connections that are available.

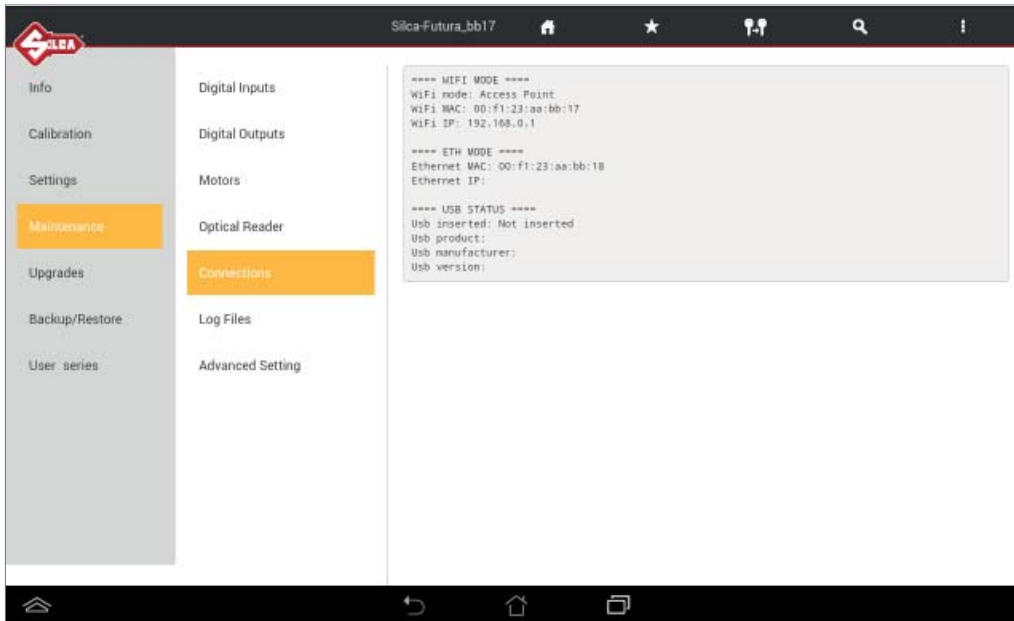

• **Log Files**

The Log file is requested by Silca when on board machine software anomalies are encountered. This function permits to create and save a log file:

- on a USB key connected to the machine’s USB port (Fig. 14). **Note: FUTURA has one USB port only.**
- or directly to Silca’s Server (with the FUTURA PRO machine connected to a local network) Wi-fi or LAN cable connection).

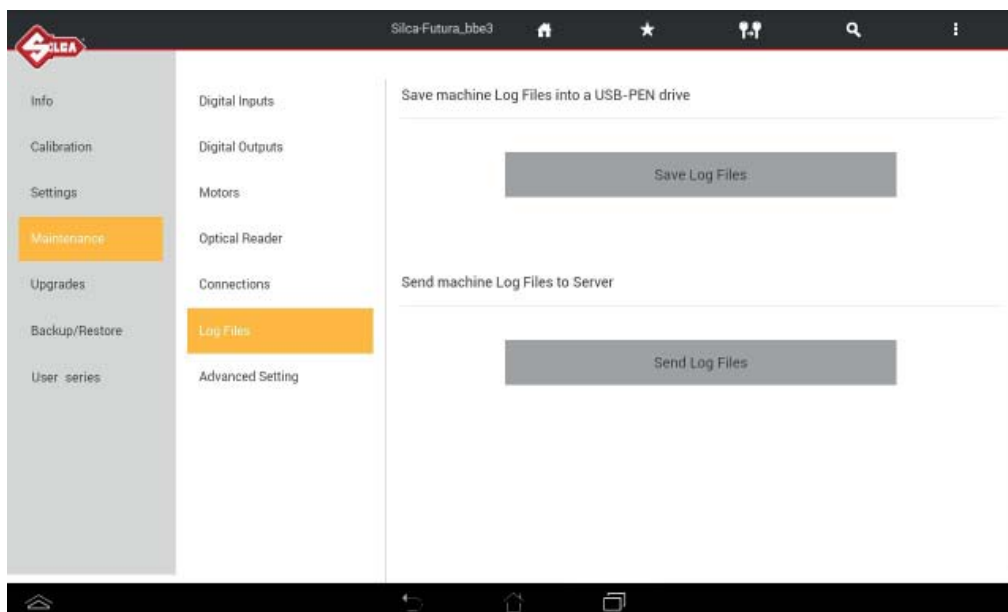

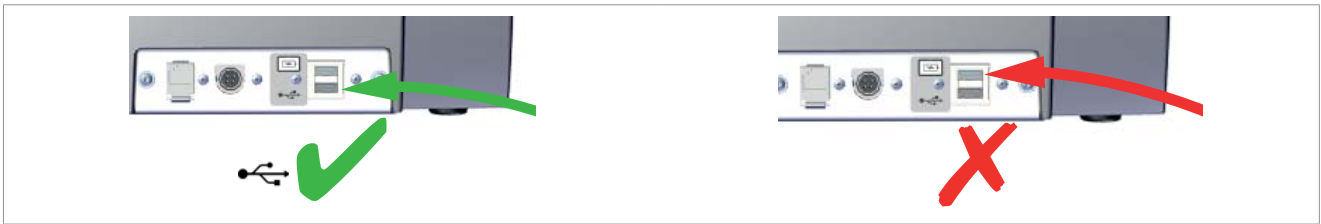
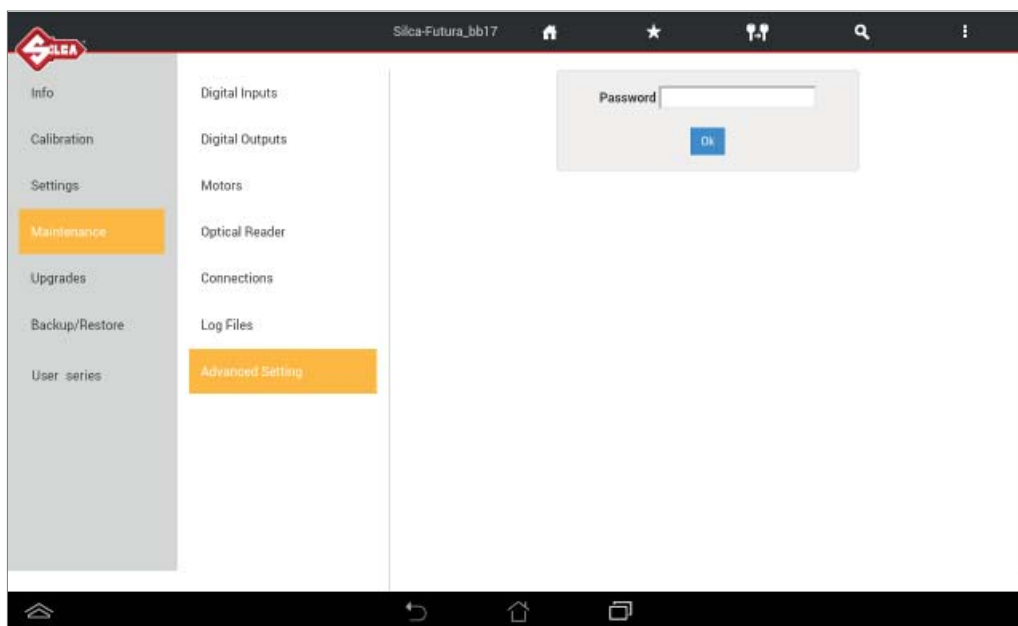

Fig. 14 - Futura PRO

- **Advanced Setting**

Function for Silca internal use.



8 MACHINE UPDATE AND REGISTRATION

8.1 MACHINE REGISTRATION

To download the machine software updates you must be registered on the SILCA WEB FUTURA server. **This operation is required only on first access.**

After cutting at least 50 keys you are required to register the machine (only if not yet done) on the Silca FUTURA web server.

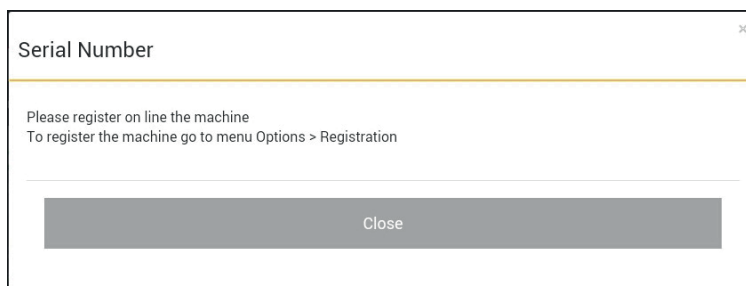

- If the machine is not registered now, the same message will appear every time Futura / Futura Pro is started.
- If the machine is not registered it will not be possible to download software updates.

There are 4 ways to register:

Method 1: Futura / Futura Pro machine with access to the internet

Method 2: Futura / Futura Pro tablet with access to the internet

Method 3: Using the Silca Remote Service (SRS) program

Method 1

Futura / Futura Pro machine with access to the Internet

- Start the FUTURA program; tap the icon OPTIONS -> Settings -> Registration
- Enter the data into the fields shown (those with * are required) and then tap Register and wait for a message communicating that the machine has been registered. Tap Close.

The screenshot shows the registration interface of the Futura Pro machine. On the left is a sidebar menu with options: Info, Calibration, Settings (highlighted), Maintenance, Upgrades, Backup/Restore, and User series. The main content area is titled 'Registration' and contains a form with the following fields: Serial Number (111111111111), Company* (Silca Italia), Last Name (Silca), First Name (Silca), Address (Via Podgora 18/20), City* (Vittorio Veneto), Country* (it), and Email* (****@silca.it). A red message at the top states: 'Waiting for Email confirmation. To complete the registration, it's required to confirm the received Email and press the button CHECK of this screen'. There is a 'Retend the activation email' button next to the email field. At the bottom are 'Check' and 'Register' buttons. The top status bar shows 'Silca-Futura_bbe3' and various icons.

NOTE: Tap  to view the registration method for FUTURA PRO machines.

A message confirming registration will arrive at the address given.

Use your mail program to open the e-mail from Silca and click on “Validating email”.

The screenshot shows an email validation message. The header is 'Email address validation'. The body text reads: 'Your email address has not been validated. Click on the link below to validate the email address entered.' There is a faint link below the text.

At the end, tap “Close” and then “Check” to conclude the registration procedure on the Tablet.

Method 2

Futura / Futura Pro tablet with access to the internet

NOTE: the Tablet must be taken where there is a Wi-Fi connection with internet access.

Connect a tablet to your local Wi-Fi network and connect to the internet to start the Silca FUTURA APP. Scroll from left to right to open the drop-down menu, as shown below.

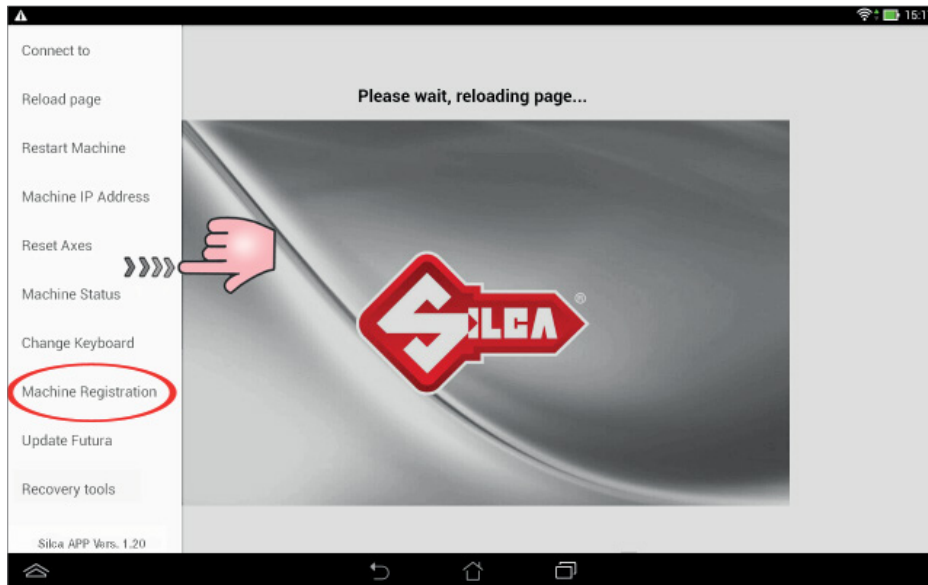

Tap “Machine Registration”.

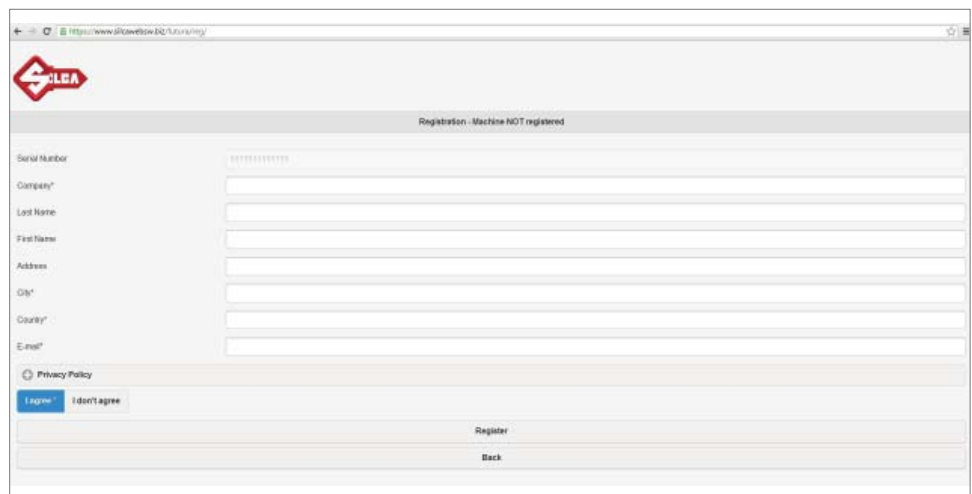
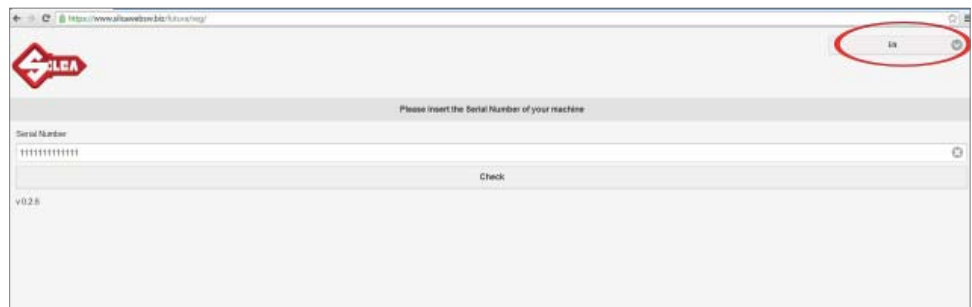

- If the serial number is not read, digit its thirteen numerical characters and press “Check”.
- Enter the data into the fields shown (those with * are required) then tap Register.

- A message confirming registration will arrive at the address given. Use your mail program to open the e-mail from Silca and click on "**Validating email**".

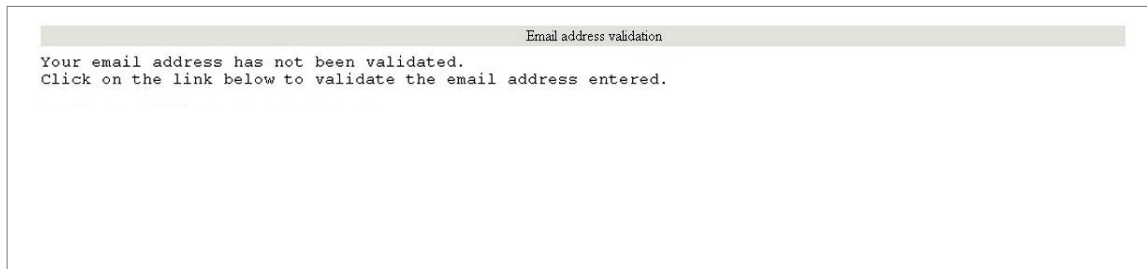

- Go back to the Futura / Futura Pro machine and re-connect in ACCESS POINT mode.

NOTE: when the machine is updated for the first time registration data will be transmitted by the Futura WEB server to the machine.

Method 3

Using the Silca Remote Service (SRS) program

Futura / Futura Pro machine and Tablet connected in ACCESS POINT mode

Install the “**Silca Remote Service**” program on your PC. The program can be downloaded from the Silca website, by selecting the Products menu -> Silca Key Programs -> SKP Modules -> Silca Remote Service.

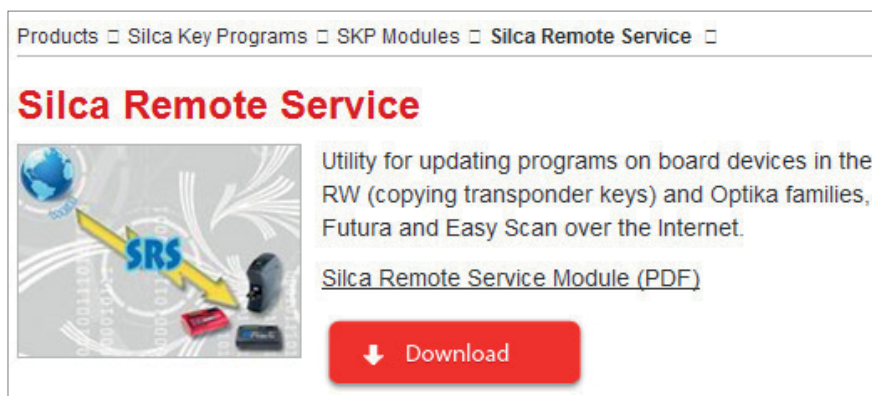

- Start the program and select the Futura / Futura Pro machine model, select the “Next” button and then “Register”: a dedicated web page will appear.
- If the machine has not already been registered, enter the data in the relevant fields (fields marked * are required) and then tap “Register”.
- A message will be sent to the given email address to confirm registration. Use your mail program to open the email from Silca and click on “**Validating email**”.

The machine is now registered.

8.2 MACHINE SOFTWARE UPDATE

Silca periodically releases Software and Data Updates for the machine. To check for new updates use one of the connection methods available.

ATTENTION: Do not insert a USB modem sticks for the transfer of data in the machine USB port.

NOTE: before starting, check that the machine is registered (shown on the Machine Registration screen - on the Tablet scroll from left to right to open the drop-down menu).

Futura / Futura Pro can be updated in one of the following ways:

- 1) Update by TABLET
- 2) Update by USB PEN DRIVE
- 3) Update through LOCAL NETWORK
- 4) Update by SRS (Silca Remote Service) program

8.2.1 Update by TABLET

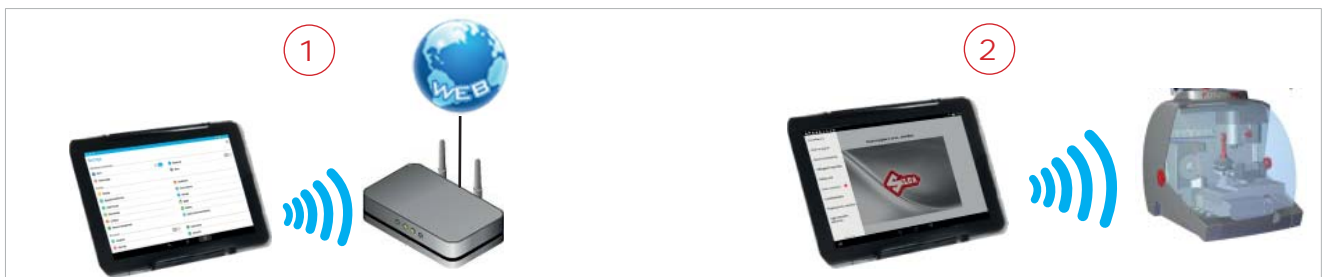

Fig. 15

ATTENTION: Make sure there is no USB PEN in the Futura / Futura Pro machine USB port during updating.

- 1) Take the tablet to a place with a Wi-Fi network and internet connection and connect.
- 2) Start the Silca Futura APP and follow the instructions on the screen:
 - On the Tablet scroll from left to right to open the drop-down menu.
 - Tap “Machine registration” (Fig. 16).
 - Enter the machine serial number (13 digits) and then tap “Check”.

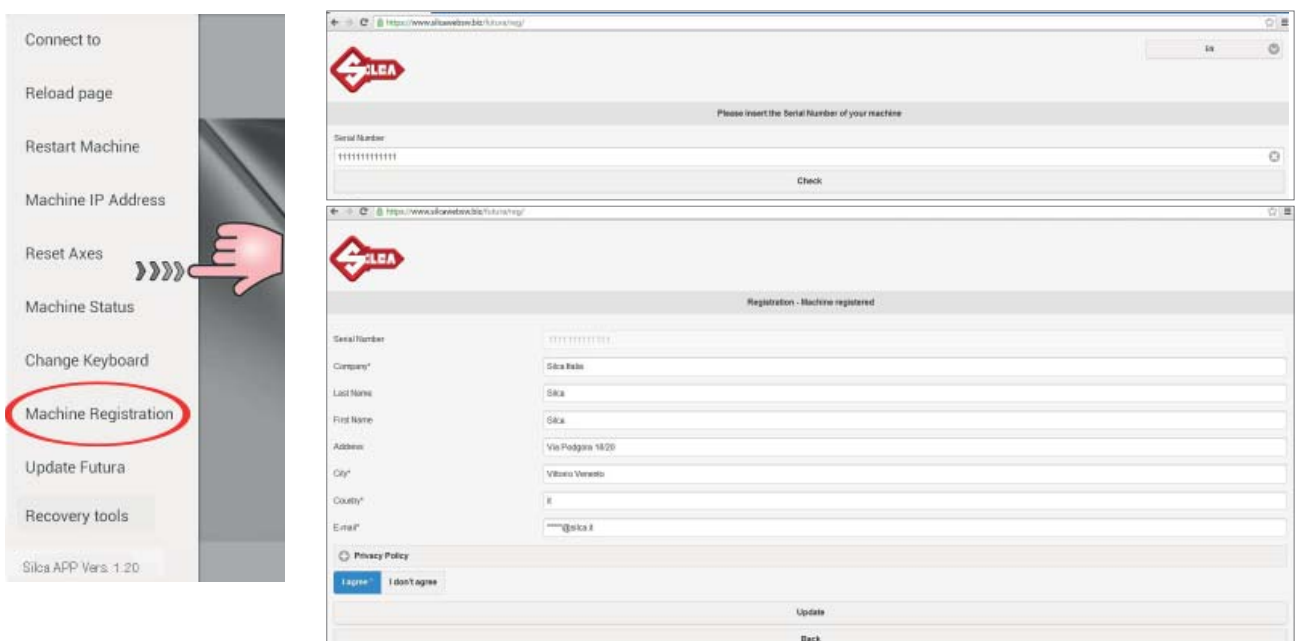

Fig. 16

- On the Tablet scroll from left to right to open the drop-down menu
- Tap “Machine update”; the following screen will appear:

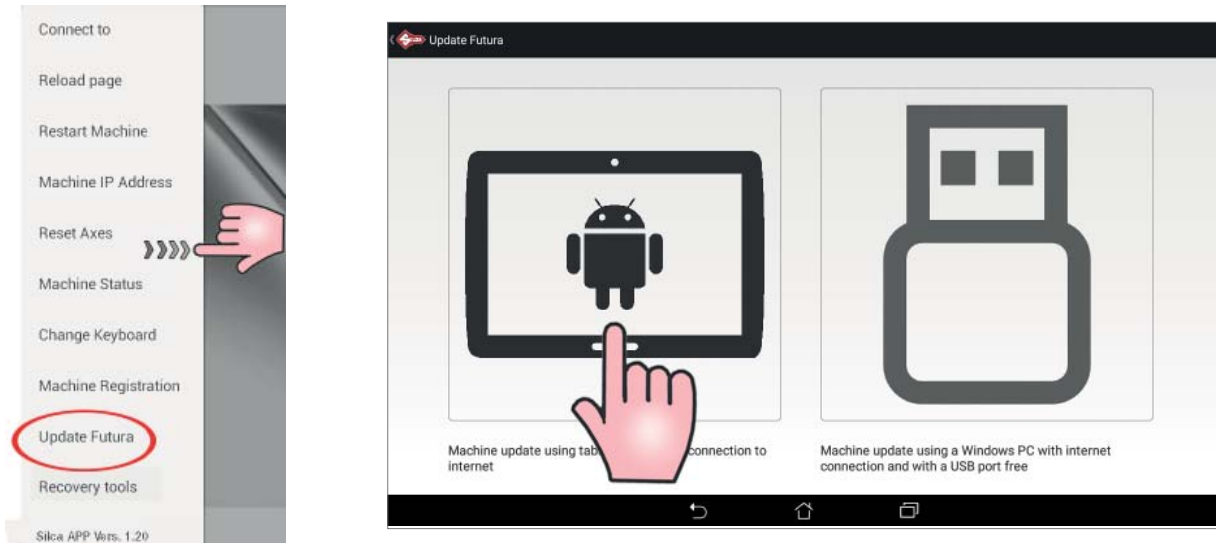

Fig. 17

- Click on the tablet image (Fig.10) and follow the guided procedure (if the tablet is not connected to a Wi-Fi network you will see a screen from which a Wi-Fi network can be selected).
- When the new update has been downloaded you will be asked to re-start the machine so that the update will be applied automatically.
- Press the “Re-start machine” button and wait a few minutes. The tablet will automatically connect to Futura / Futura Pro.

8.2.2 Update by USB PEN

This update procedure is used to update the Futura / Futura Pro machine using a PC connected to the internet and a USB PEN.

- 1) Select “Machine update” from the drop-down menu and tap the USB PEN image (Fig. 18). Insert the USB PEN DRIVE into the machine and follow the instructions on the screen.

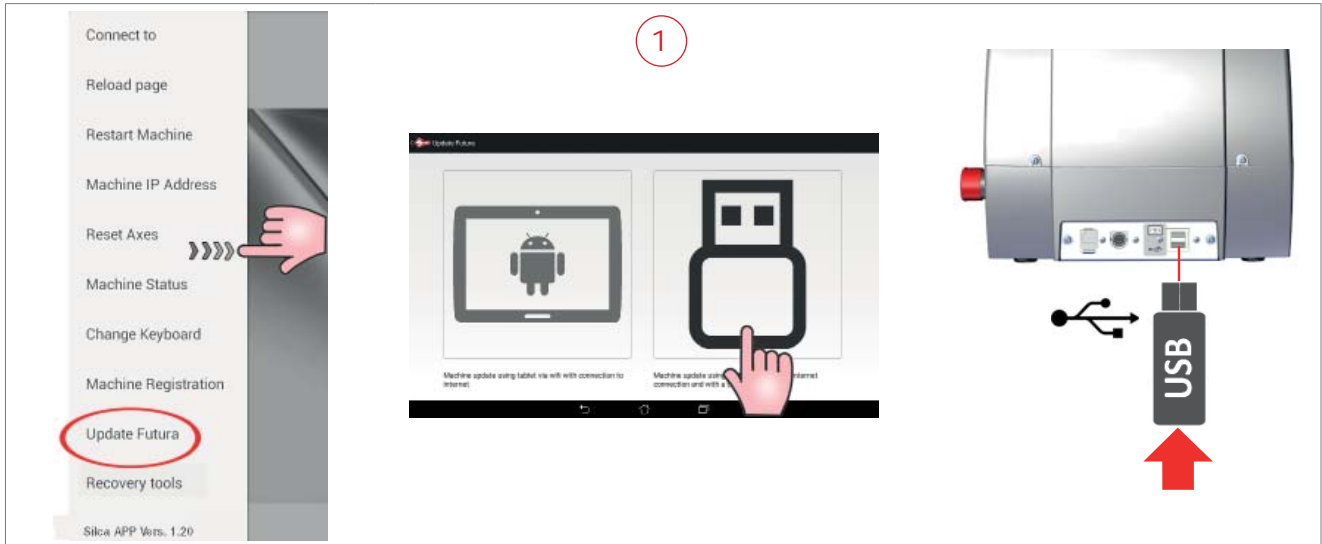

Fig. 18

- 2) Insert the USB PEN DRIVE into a PC connected to the internet (Fig. 19).
 - Open the USB PEN DRIVE, click on the file “FuturaUpgrade.exe” and wait for the “operation successful” message to appear on the screen.
 - Remove the USB PEN DRIVE from the PC (safe hardware removal).



Fig. 19

- 3) Insert the USB PEN DRIVE into the special port on FUTURA PRO (Fig. 20). **Note: FUTURA has one USB port only.** Follow the instructions on the screen: tap the “RE-START FUTURA” button to re-start the FUTURA PRO machine.
 - Wait a few minutes until the white light flashes regularly.
 - Remove the USB PEN DRIVE from the machine (without turning it off). Wait for Futura / Futura Pro to re-start (regularly flashing blue light).
 - Start the FUTURA APP from your tablet.

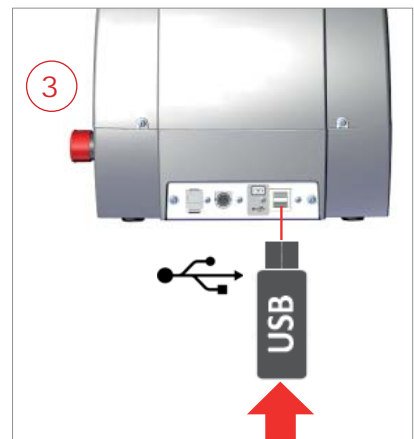

Fig. 20

8.2.3 Update with LOCAL NETWORK connected to the internet

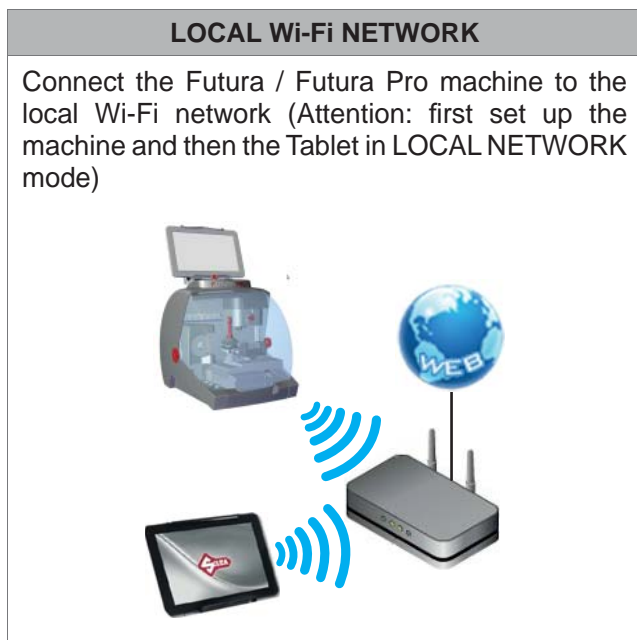

Fig. 21

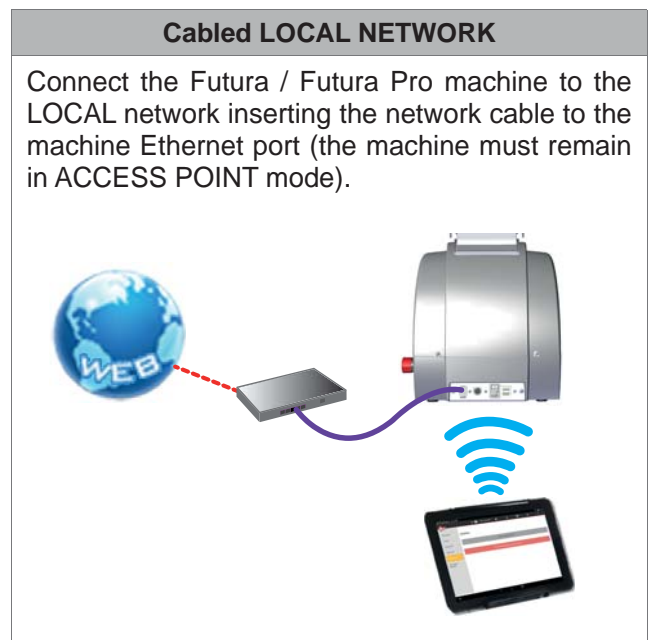

Fig. 22

ATTENTION: Make sure there is no USB PEN in the Futura / Futura Pro machine USB port during updating.

To upgrade the FUTURA PRO machines software in manual mode, follow the steps indicated below.

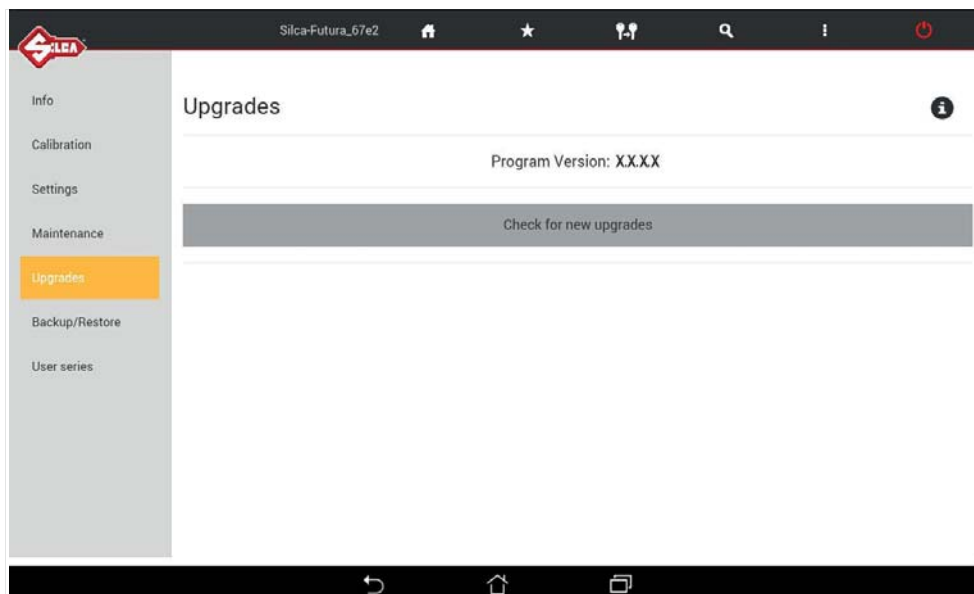



Fig. 23

NOTE: tap  to view machine update methods.

- Tap on "Check for Updates" to get a list of what will be downloaded with the update.

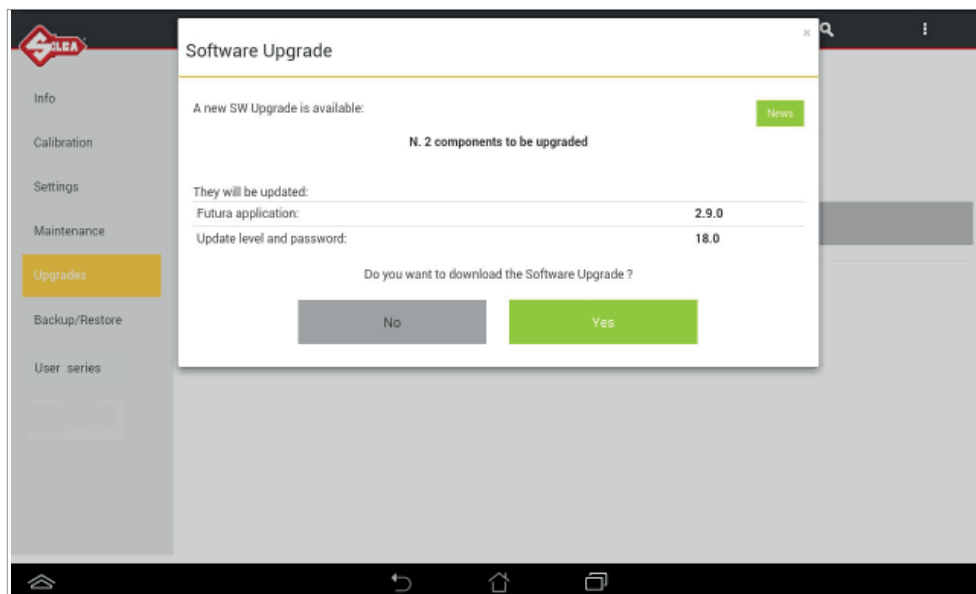

Fig. 24

- Tap “News” to see information about the update to be installed on the machine.
- Tap on “Yes” to start downloading.
- When download is over, you will be asked to restart the FUTURA PRO machine (procedure run by the software). Follow the on-screen instructions.

8.2.4 Update with SRS Program (Silca Remote Service)



Fig. 25

Install the “Silca Remote Service” program on your PC. The program can be downloaded from the Silca website by selecting the Products menu -> Silca Key Programs -> SKP Modules -> Silca Remote Service



The machine can be updated in the following ways:

Method 1 (QUICK update)

QUICK update saves time as it downloads only the files needed.

ATTENTION: you need a blank FAT32/NTFS format USB PEN.

- Fit a blank format FAT32/NTFS USB PEN into the Futura / Futura Pro machine and open the machine software; go to the Diagnostics menu -> Log File and press “Save log file” on the USB PEN.
- Fit the USB PEN into the PC on which the SRS program is installed, go to the SRS program screen regarding **QUICK update** preparation and wait for the update file to be saved on the machine. If the machine is not registered you will be required to register using the special website page.
- Ensure that the Futura / Futura Pro machine is off (red push button) and that the FUTURA APP on the Tablet is closed.
- Fit the USB PEN into the machine USB port (on the rear of the machine - Fig. 14, page 68).
- Start the FUTURA PRO machine and wait a few minutes until the white light flashes regularly. Remove the USB PEN (without turning off the machine). Wait for Futura / Futura Pro to re-boot (blue light flashing regularly). Start the Futura APP from your Tablet.

ATTENTION: do not unplug or turn off Futura / Futura Pro during updating.

Method 2 (TOTAL update)

TOTAL update will download all the files on the machine

Start the program  and select the Futura / Futura Pro machine.

ATTENTION: you need a blank FAT32/NTFS format USB PEN.

- Enter the Futura / Futura Pro machine serial number into the SRS program screen regarding update preparation and then fit a USB PEN into the PC. Wait for the **TOTAL update** file to be saved on the USB PEN. If the machine is not registered you will be required to register using the special website page.
- Ensure that the machine is off (red push button) and that the FUTURA APP on your Tablet is closed.
- Fit the USB PEN into the machine USB port (on the rear - Fig. 14, page 68).
- Start the Futura / Futura Pro machine and wait a few minutes until the white light flashes regularly. Remove the USB PEN (without turning off the machine). Wait for Futura / Futura Pro to re-boot (blue light flashing regularly). Start the Futura APP from your Tablet.

ATTENTION: do not unplug or turn off Futura / Futura Pro during updating.

8.3 APP UPDATE (Silca.apk and SilcaKeyboard.apk)

After you updated the Futura / Futura Pro machine’s software, when the program starts up, you may see the following screen indicating that a new version of the **Silca.apk** or **SilcaKeyboard.apk** is available.

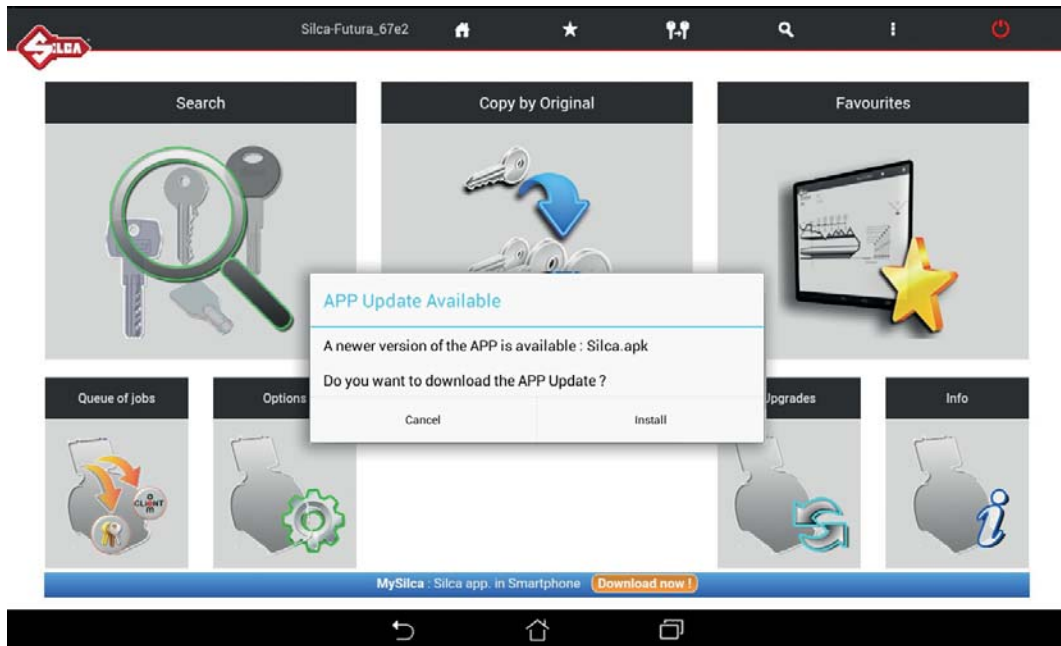

Fig. 26

Tap on “Install” and proceed with updating the APP.

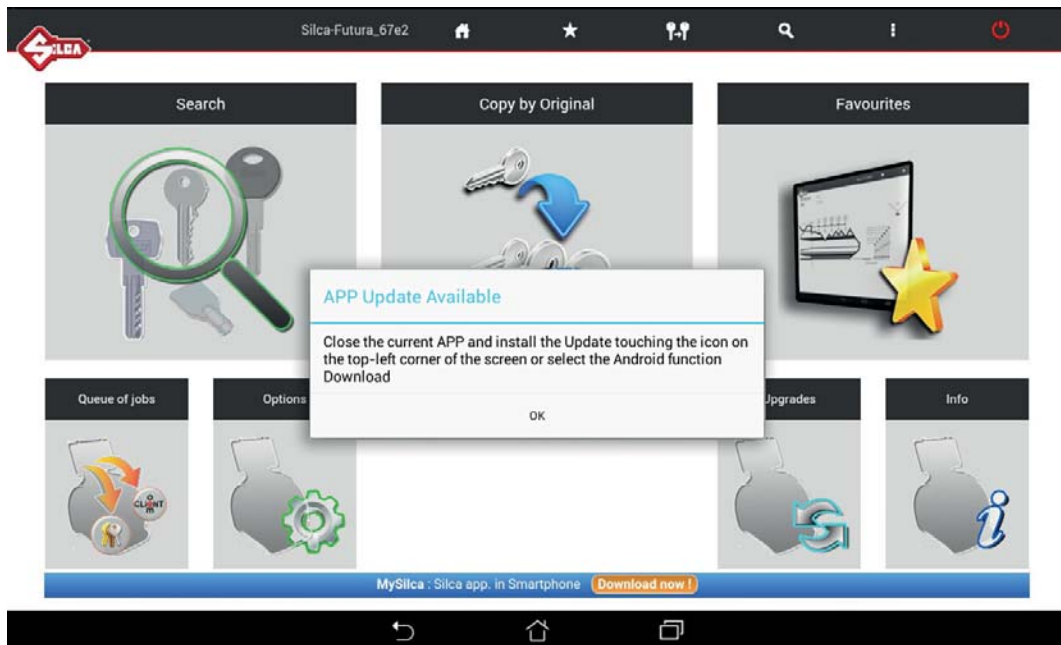

Fig. 27

Close the application that is opened by tapping on  and dragging the Futura APP downwards off the screen (see Fig. 28).

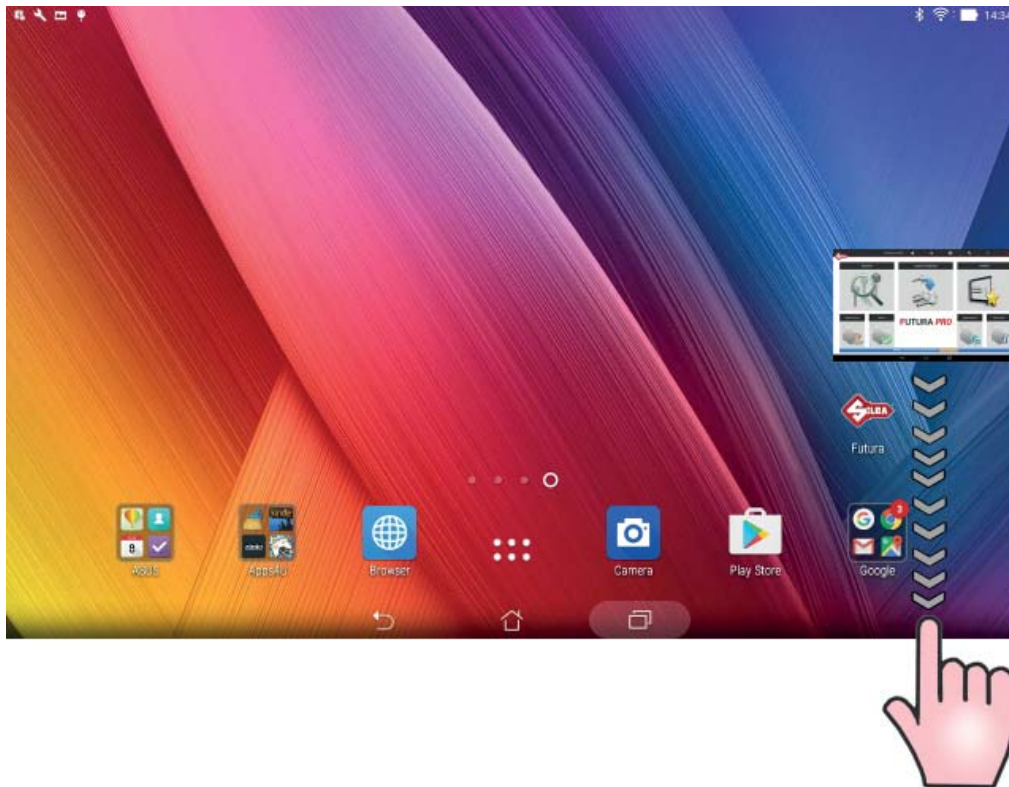

Fig. 28

Select "Downloads" from the tablet "Setting" menu  (Fig. 29).

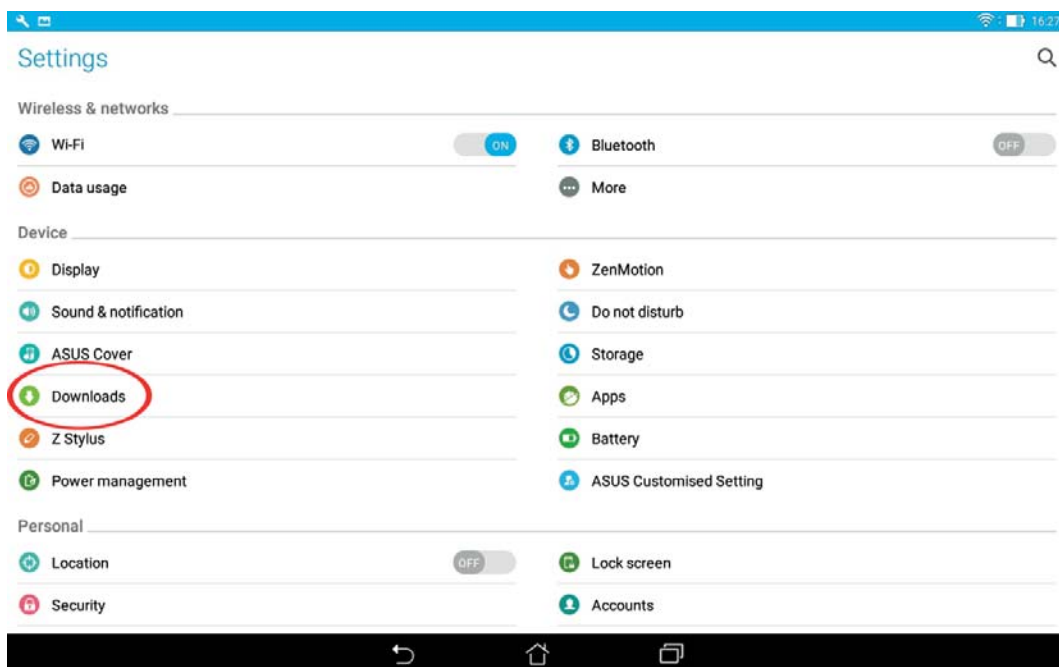

Fig. 29

Select **Silca.apk** and tap on “Install” (Fig. 30).

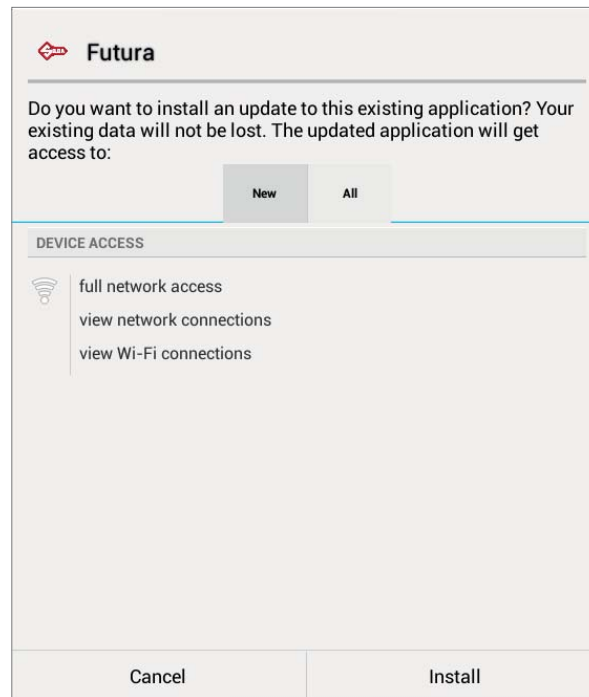

Fig. 30

Wait for the update to finish.

Do the same for upgrading the **SilcaKeyboard.apk**.

9 BACKUP / RECOVERY

This function permits to create and save a backup (backup User database) file in a USB pen that can be connected the machine's USB port (Fig. 14, page 68).

Also provided is the recovery (Restore User database) function always using the USB pen with the last file that was saved on it.

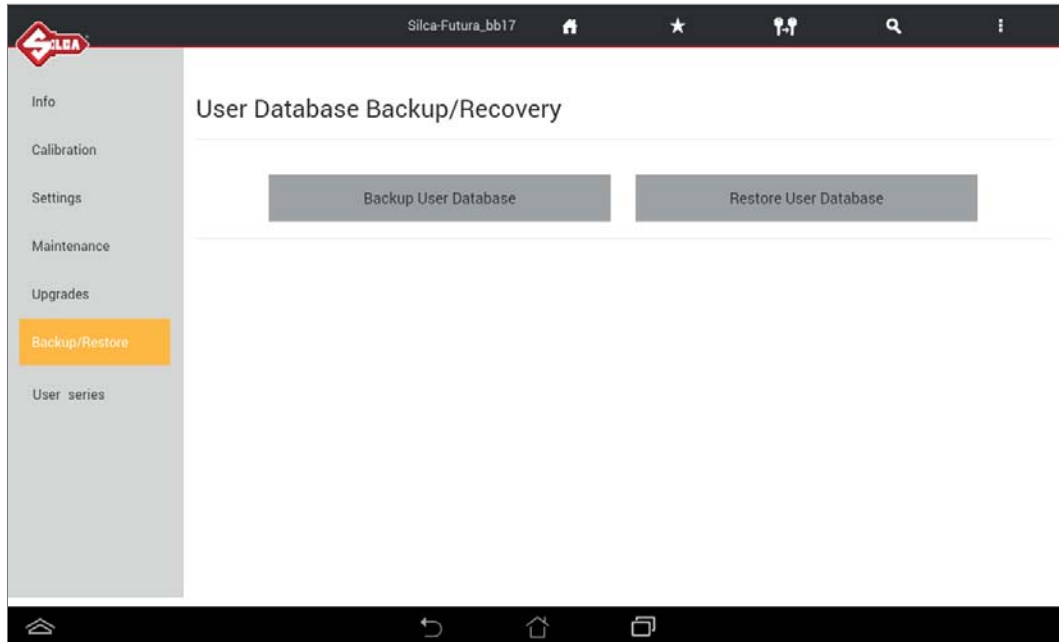

10 USER SERIES

Function accessible from “Options => User Series”.

This function is available to the user to import a code table in XML-Keso, CSV, TXT format, associating it to a data card and thereby creating a new user series.

- Use a USB-PEN, FAT32/NTFS format, and copy onto it the file (or files) with the table to be imported. **Note: the file must not be in a folder.**
- Insert the USB-PEN into the Futura / Futura Pro USB port (Fig. 14, page 68).

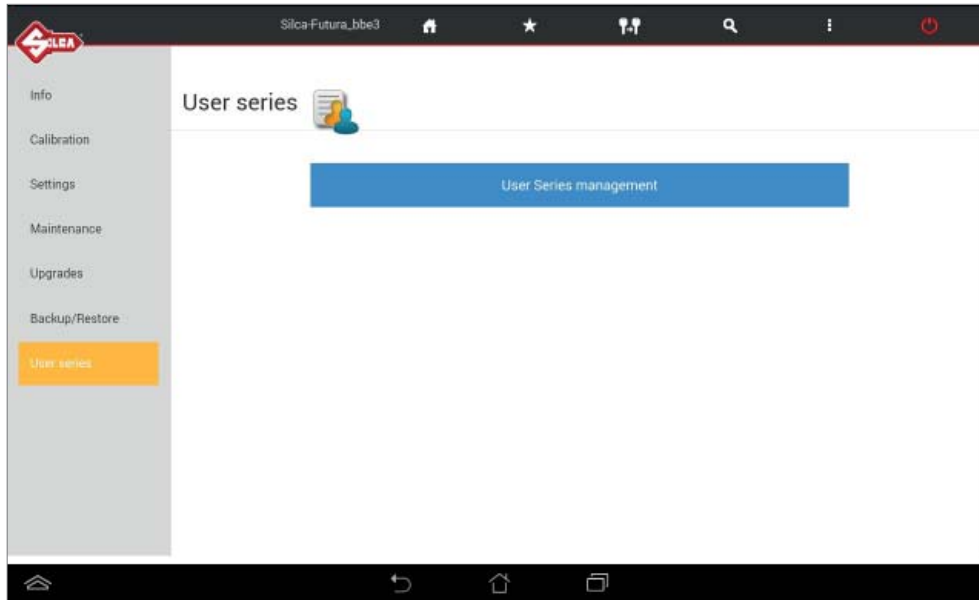

To create the user series, tap “User Series Management”.

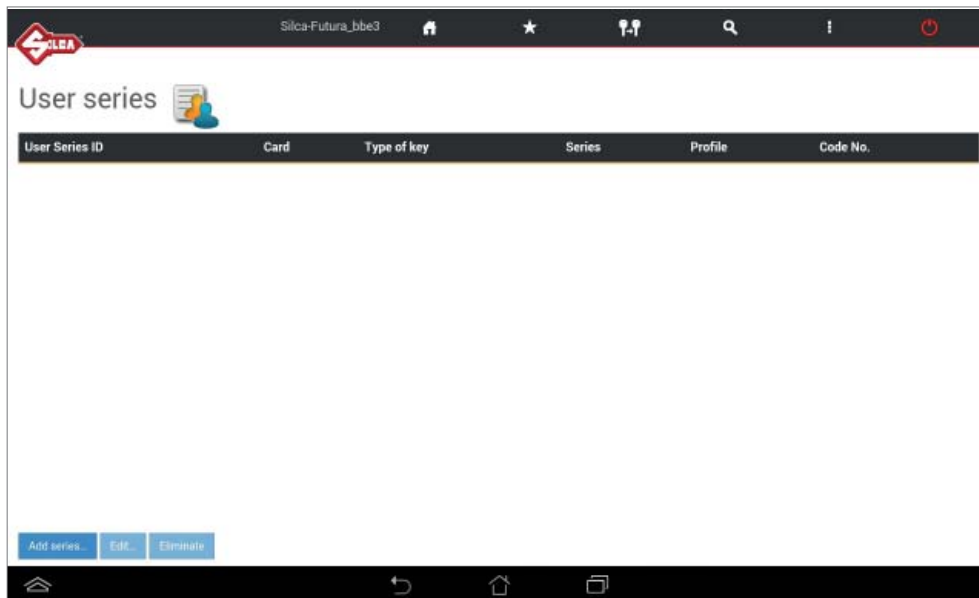

Tap “Add Series” to import the new file.

When the User Series exists and is selected/highlighted you can:

- Tap the “Edit” key to vary certain parameters associated to the series.
- Tap the “Eliminate” key to erase the selected series.

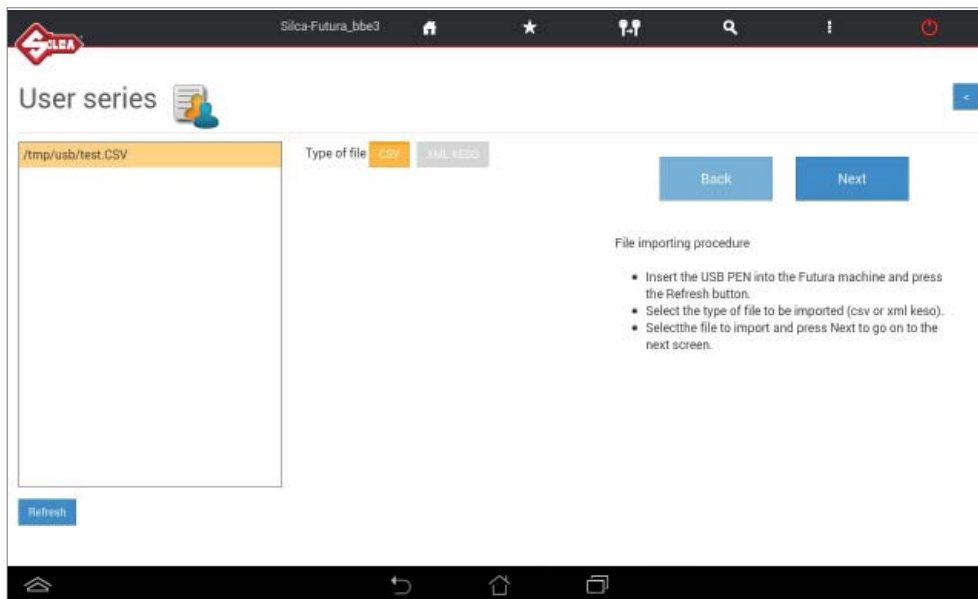

- Follow the instructions on the Tablet page. During guided import you will be required to enter or select certain parameters to associate to the new series (e.g. Data card number, Profile, Series, Makes, Applications and Key blank).
- Tap “Next” to continue.

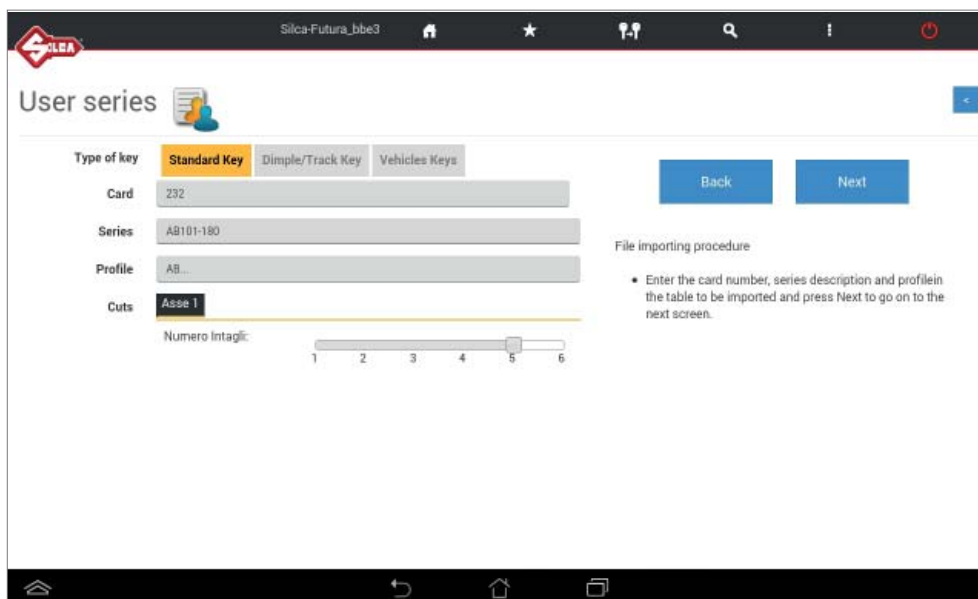

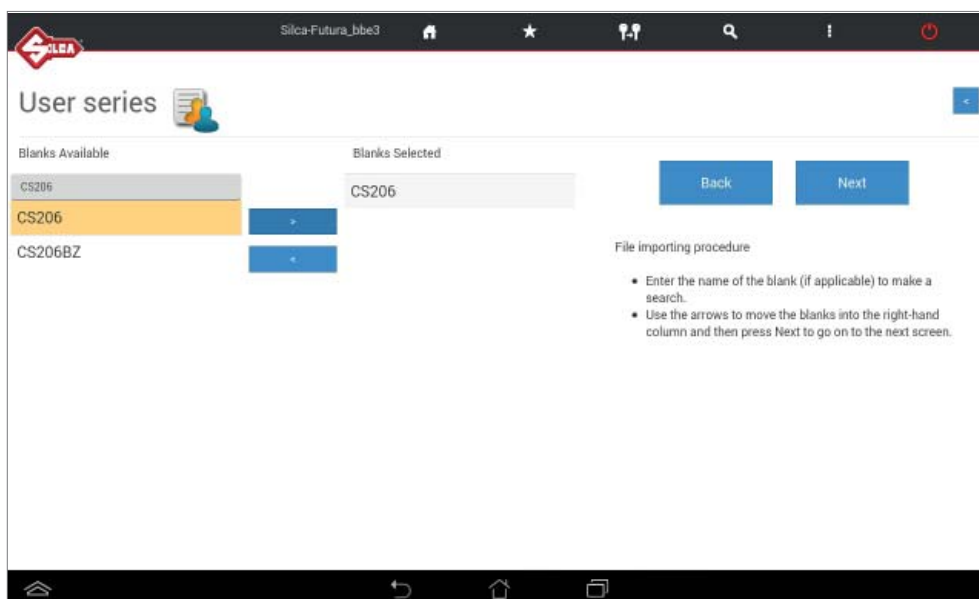
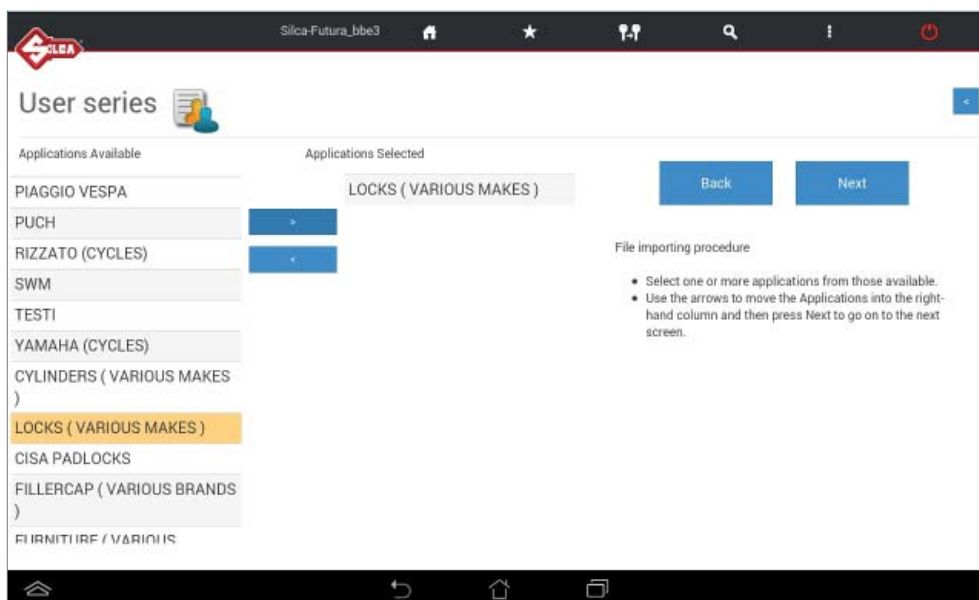
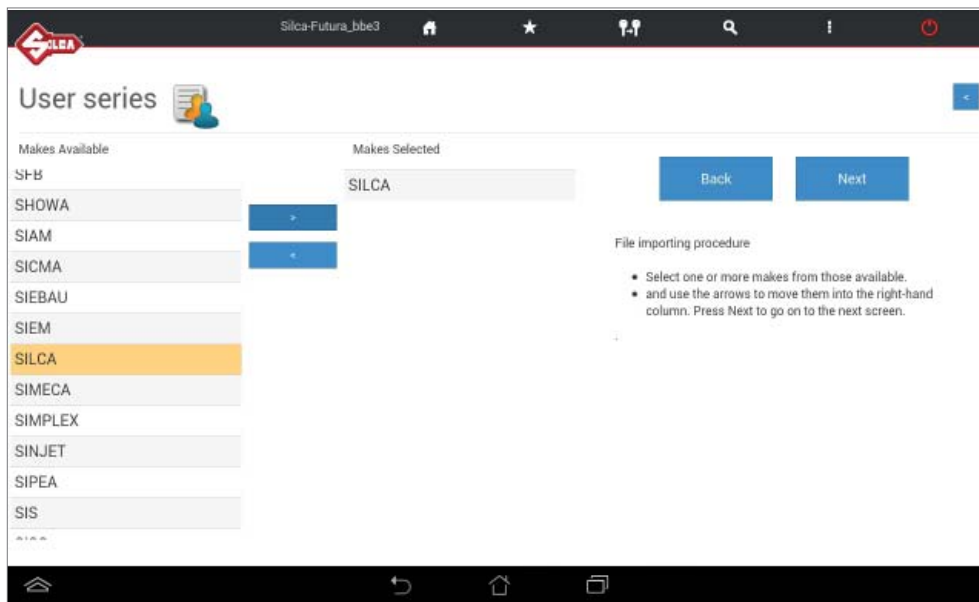

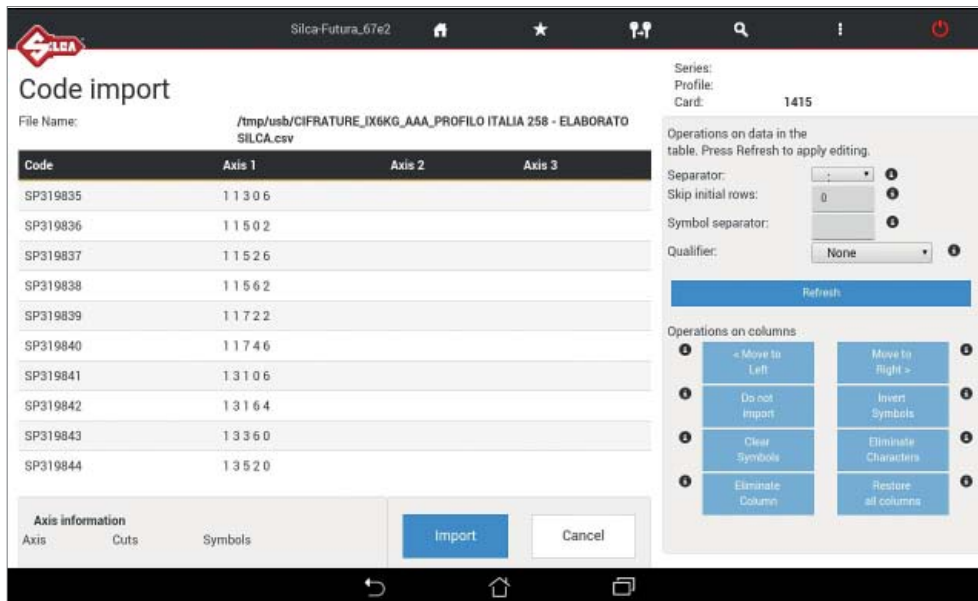

- Tap “Import” to import the file directly without editing.

NOTE: only if necessary, before terminating table import you can edit certain parameters using the menu on the right (Operation on data in the table and/or Operations on columns).

NOTE: tap  to view information about the field.

- After editing the parameters “Operation on data in the table” tap the “Refresh” key”.
- After carrying out operations in the columns, tap the “Import” button to start importing the files.

At the end of the operations the following screen will appear:

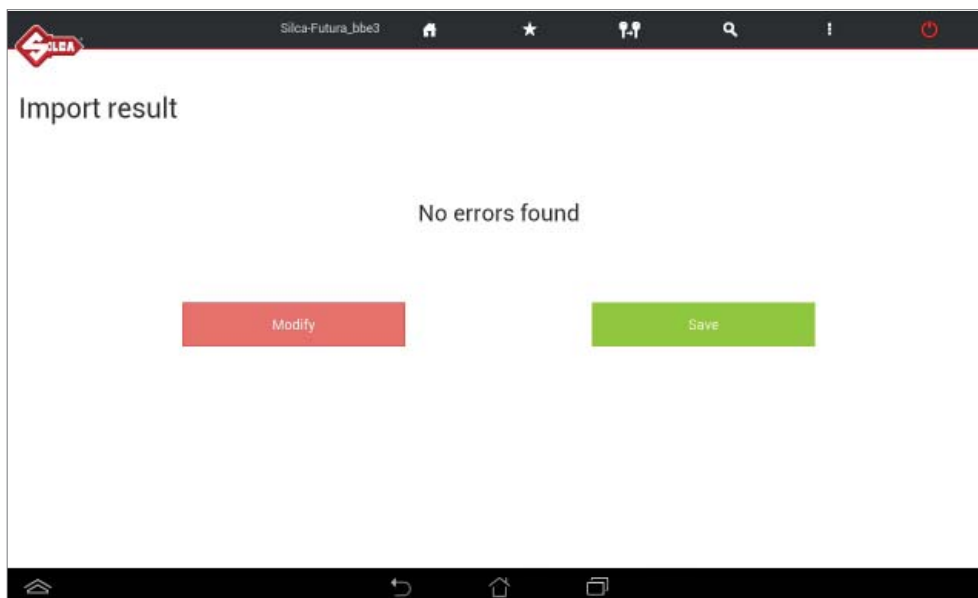

- Tap “Save” to save the new User series.
- Tap “Modify” to make changes.

11 CODE MAKER

The Code Maker function (option to buy) is used to create a new data card with user-definable cutting parameters.

An explanation of how to use the data card parameters is given in the User Data Card guided creation procedure.

When the data card has been created the program proposes the creation of a User Series which also serves as a link to a personal code table.

Note: new data cards can be created using the accessories, cutters and clamps listed below:

Data cards for FLAT/STANDARD keys

Clamp to be used: **01V or 01VJ**

Cutter to be used: **01F**

Data cards for DIMPLE keys

Clamp to be used: **01R**

Jaws to be used: **01J-02J 05J-06J**

Cutter to be used: **01D - 02D - 03D - 04D - 05D - 07D - 13DW**

Note: Code Maker may use other accessories in the future.

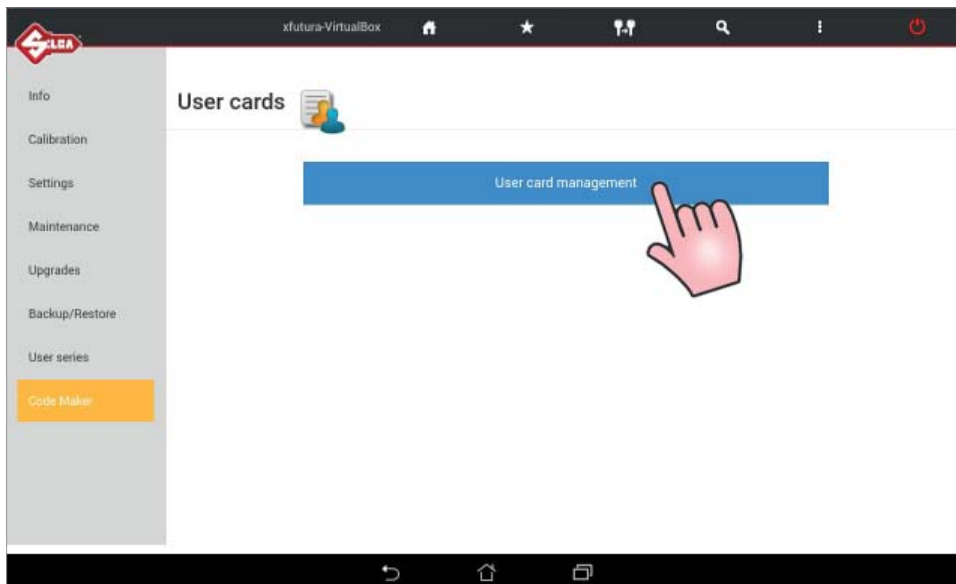

12 TRANSPONDER GUIDE



The Transponder Guide contains all the transponder key copying solutions provided by Silca. Open the Transponder Guide MENU - the search window will appear. Enter into the fields the known information about the vehicle or transponder key to view data relating to identification, copying, storage and the procedures provided by Silca:

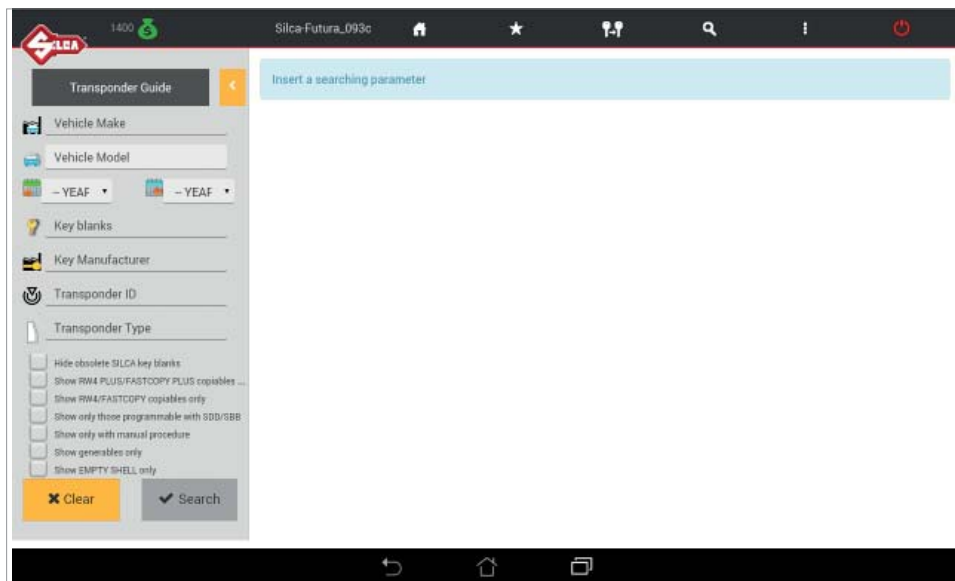

IMPORTANT:

- tap the column icon to learn the meaning of each column
- press the orange arrow  to make a new search or go back

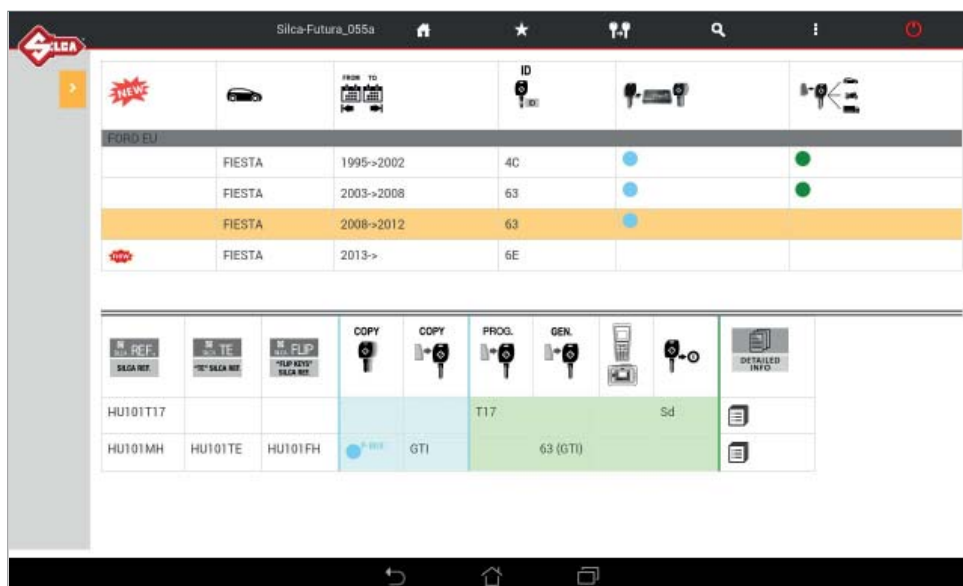

Fig. 31

Select the required car model at the top of the window.

The bottom part of the window will show detailed information about the different possibilities:

Blue section

- use one of the Silca keys indicated in the first 3 columns to create a clone of the original transponder key, i.e. a key ready for use.

Green section

- use one of the Silca keys indicated in the first 3 columns to get a key that can be programmed on the vehicle by diagnostics or manual procedure. If there is no solution with Silca keys, when programming by diagnostics or manual procedure, if available, the copy must be made from an original key.



column indicating a Silca key blank complete with transponder or ORIGINAL



column indicating a Silca key blank without transponder



column indicating a Silca FLIP key blank without transponder

Example Fig. 31

In this case the user may:

Blue section => to clone the original key with RW devices

- use HU101MH
- use HU101TE or HU101FH with GTI transponder

Green section => to programme a key on the vehicle with original diagnostics (sd = see dealer)

- use HU101T17
- use HU101TE or HU101FH with GTI transponder programmed as ID63 or with T17 transponder

Get further details or access “manual programming” procedures by hitting  (see Fig. 31).

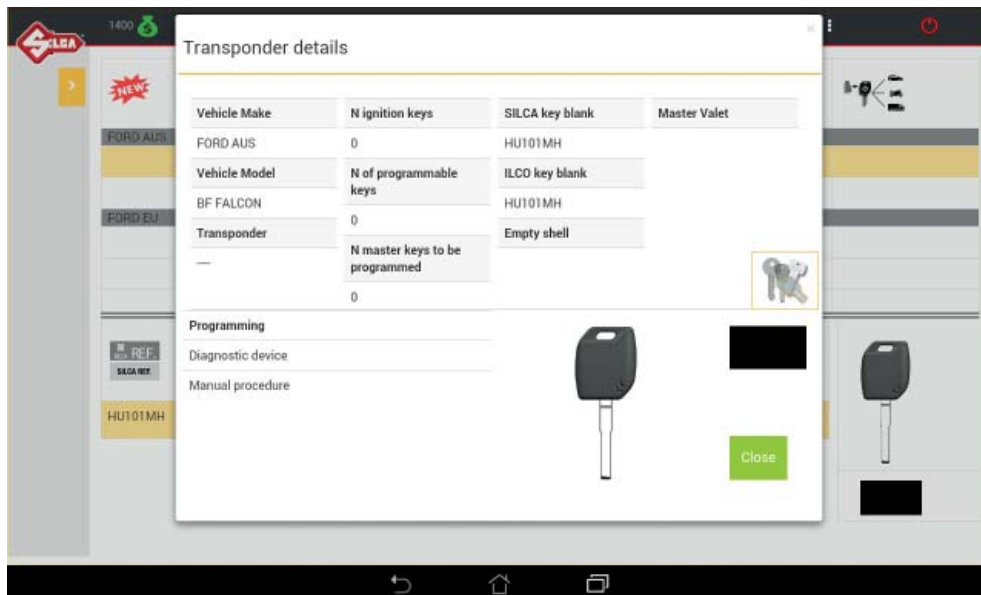

Tap icon  to make a search in the key-cutting section to find the data cards for the Silca key blank selected.

13 “TOKEN” AND “UTP” (UNLIMITED TOKEN PLAN)

Token machines are a new “pay per use” concept applied to Futura / Futura Pro machines which employ special tokens purchased by the customer as and when needed.

There are 2 types of tokens:



“Token”: “digital coins” whose value decreases every time a copy of a key is made. When the tokens are finished new ones must be purchased to continue using the key-cutting machine.



“UTP (Unlimited Token Plan)”: a special “timed digital coin” that allows the machine to be used freely (i.e. an unlimited number of keys can be cut) for a given period (a few months up to a year). At the end of the period new tokens must be purchased to continue using the key-cutting machine.

NOTE: To apply for token recharge and/or a “UTP” package the machine must be registered (to register see Ch.8.1 MACHINE REGISTRATION).

Running “Tokens” and “UTPs”

The following procedures apply when a newly recharged token or “UTP” package is used, according to the type of system on the machine.

| In use on the machine | New | System |
|-----------------------|-------|---|
| UTP | UTP | Duration of the UTP package in use is extended by adding the duration of the new one. |
| Token | Token | The new tokens are added to those already in use. |
| UTP | Token | The tokens will be operative when the UTP package expires. |
| Token | UTP | The tokens will be operative when the UTP package expires. |

About tokens and “UTPs”

One of the following two icons is situated in the top left-hand corner, close to the SILCA logo:

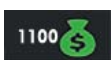

The “Tokens” still available

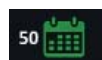

Days of use in the case of “UTPs”

To view information about the tokens available/used, tap



To view the days still available in the case of “UTPs”, tap

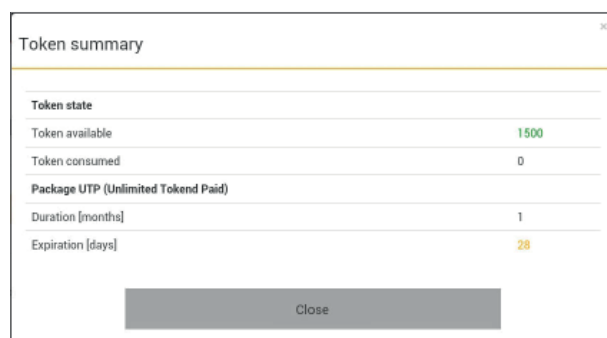

- When the icon (Token) and/or calendar (UTP) are green it means that the tokens or days are in excess of the minimum warning point in the Token => Settings menu
- When the icon (Token) and/or calendar are yellow it means that the tokens or days are below the minimum warning point in the Token => Settings menu
- When the icon (Token) and/or calendar are red it means that the tokens or days have expired or are about to expire.

Extratoken

If the customer has used up all the tokens or the UTPs have expired, SILCA provides the opportunity to cut keys for another 21 days.

The tokens consumed will be counted during this period.

At the end of the 21 days the machine will cease to cut keys and a new UTP package or tokens must be purchased from a SILCA distributor.

If the customer purchases a pack of tokens those consumed during the ExtraToken period will be deducted.

Example:

| Days | 1 | 2 | 3 | 4 | 5 | 6 | 7 | 8 | 9 | 10 | 11 | 12 | 13 | 14 | 15 | 16 | 17 | 18 | 19 | 20 | 21 |
|--------|---|----|---|----|---|----|---|----|---|----|----|----|----|----|----|----|----|----|----|----|----|
| Tokens | | 50 | | 50 | | 50 | | 40 | | 40 | 40 | | 10 | | | | | | | | |

Tokens consumed in the ExtraToken period: **280**

Package purchased: **1500 tokens**;

When the package is installed the machine will have **1220 tokens** at its disposal.

If the customer purchases a UTP package the days used during the ExtraToken period will be deducted according to the following logic: the last day on which key-cutting took place is counted.

Examples:

(X = one or more keys cut)

| | | | | | | | | | | | | | | | | | | | | |
|---|---|---|---|---|---|---|---|---|----|----|----|----|----|----|----|----|----|----|----|----|
| 1 | 2 | 3 | 4 | 5 | 6 | 7 | 8 | 9 | 10 | 11 | 12 | 13 | 14 | 15 | 16 | 17 | 18 | 19 | 20 | 21 |
| X | | | | | | | | | | | | | | | | | | | | |

One day will be deducted from the duration of the UTP package in question.

| | | | | | | | | | | | | | | | | | | | | |
|---|---|---|---|---|---|---|---|---|----|----|----|----|----|----|----|----|----|----|----|----|
| 1 | 2 | 3 | 4 | 5 | 6 | 7 | 8 | 9 | 10 | 11 | 12 | 13 | 14 | 15 | 16 | 17 | 18 | 19 | 20 | 21 |
| X | | | | | | | | | X | | | | | | | | | | | |

10 days will be deducted from the duration of the UTP package in question.

| | | | | | | | | | | | | | | | | | | | | |
|---|---|---|---|---|---|---|---|---|----|----|----|----|----|----|----|----|----|----|----|----|
| 1 | 2 | 3 | 4 | 5 | 6 | 7 | 8 | 9 | 10 | 11 | 12 | 13 | 14 | 15 | 16 | 17 | 18 | 19 | 20 | 21 |
| | | | | | | | | | | | | | | | | | | | X | |

20 days will be deducted from the duration of the UTP package in question.

| | | | | | | | | | | | | | | | | | | | | |
|---|---|---|---|---|---|---|---|---|----|----|----|----|----|----|----|----|----|----|----|----|
| 1 | 2 | 3 | 4 | 5 | 6 | 7 | 8 | 9 | 10 | 11 | 12 | 13 | 14 | 15 | 16 | 17 | 18 | 19 | 20 | 21 |
| | | | | | | | | | | | | | | | | | | | | |

No days will be deducted.

Note: Futura Token / Futura Pro Token is sold without tokens. When the first key is cut a "UTP" is automatically activated free for one month. At the end of the month you will be informed on your Tablet that you have 3 weeks (21 days) your disposal to purchase the token solution that meets your needs, according to calculations regarding use of the machine. At the end of the 3 week period the machine will no longer cut keys. To continue using the machine contact a Silca distributor to purchase tokens or UTPs and set up the machine for the chosen mode ("Tokens" or "UTPs").

13.1 TOKEN APPLICATION ON THE MACHINE

TOKENS on the machine can be updated in the ways described below:

- **Futura / Futura Pro machine with LOCAL NETWORK (LAN) connection:**

Select the “**Update**” menu in the Futura program and press “**Check Updates**”. If the Silca server has tokens ordered/available a message will appear with a request to download. The tokens will be downloaded automatically to the machine without the need to re-boot.

When the tokens have been updated a message will appear to indicate whether a machine software update is available on the Silca Server.

- **Futura / Futura Pro machine with ACCESS POINT connection:**

Use the “**SILCA REMOTE SERVICE**” program or take your Tablet to a Wi-Fi connection point with access to the internet. If an update is available on the Silca server the tokens ordered/available and the machine software update will be downloaded together in a single operation.

13.2 COPY BY ORIGINAL AND DATA CARD CUTTING FLOW (on Token version)

Before each cutting operation by data card, by code or from an original, the Tablet shows the cost or “token value” of the chosen cutting operation. This information is not visible if a UTP package is used.

- **COPY BY ORIGINAL**

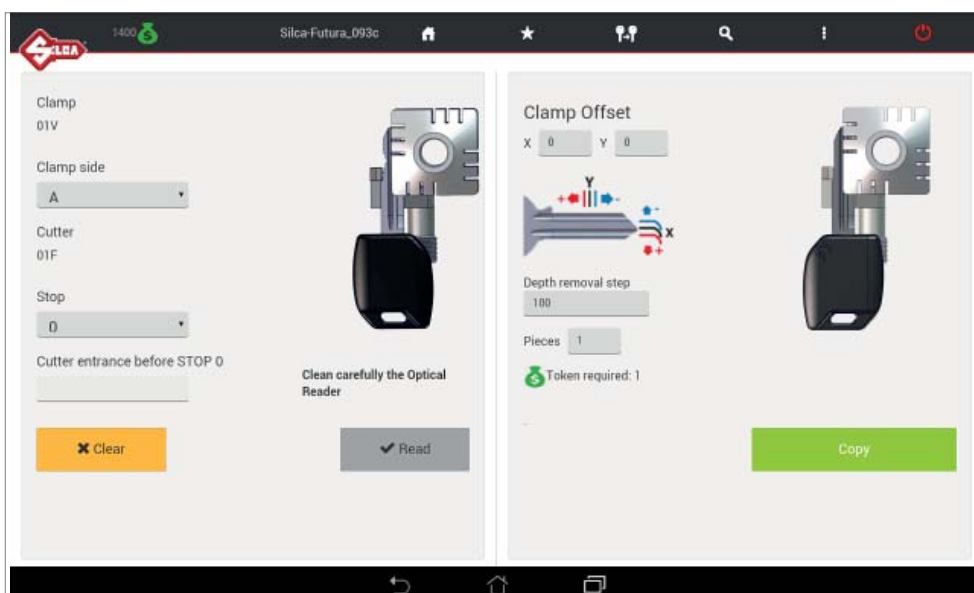

- **COPYING BY CARD**



At the end of the “Copy by data card” or “Copy by original” flow a window appears on your Tablet showing the cost of the operation (tokens consumed). This information is not visible if a UTP package is used.

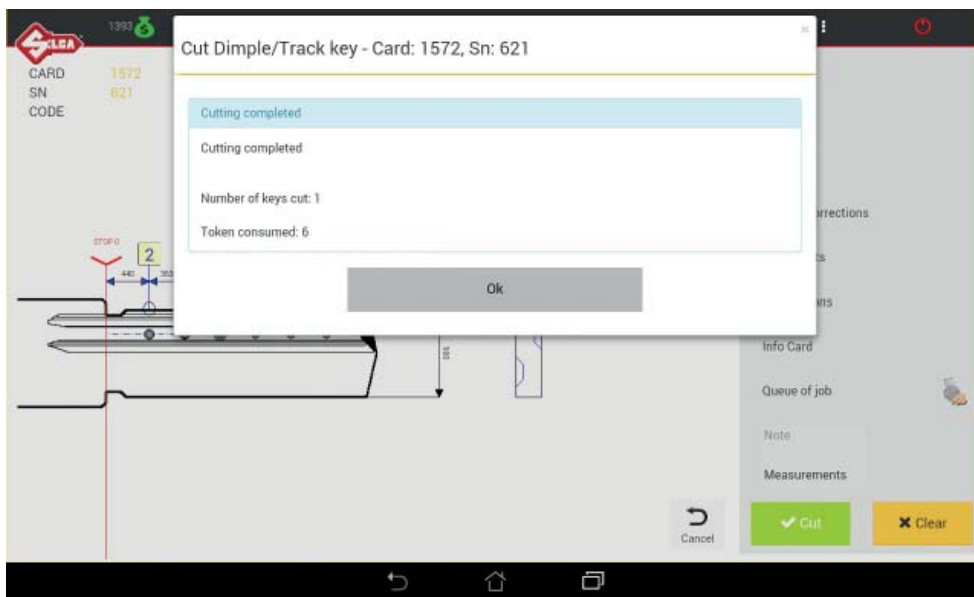
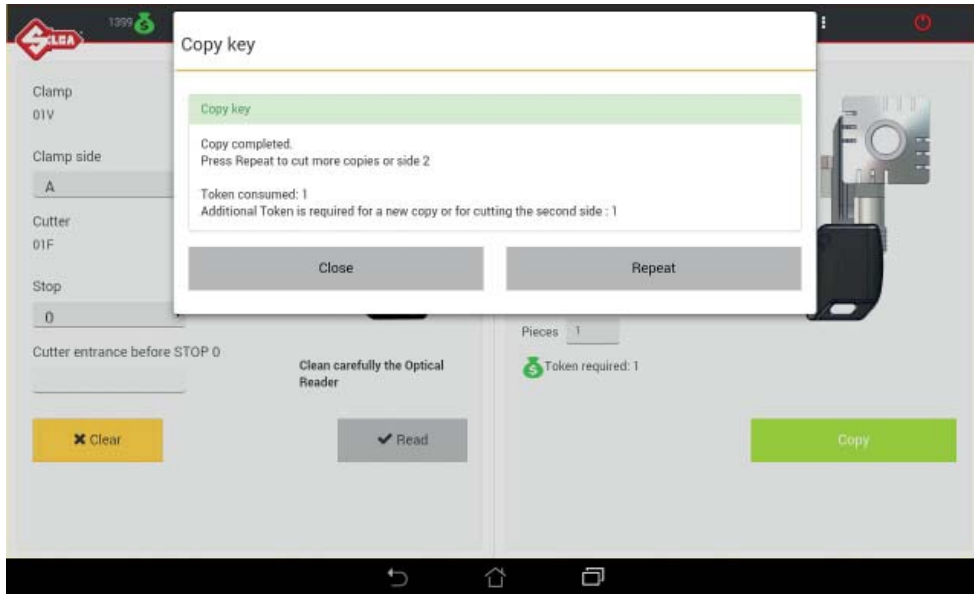

Summary of TOKEN or UTP situation

In the Options menu of the Silca Futura program tap “**Token**” and then “**Info**” to view a summary of the data and statistics relating to the token system.

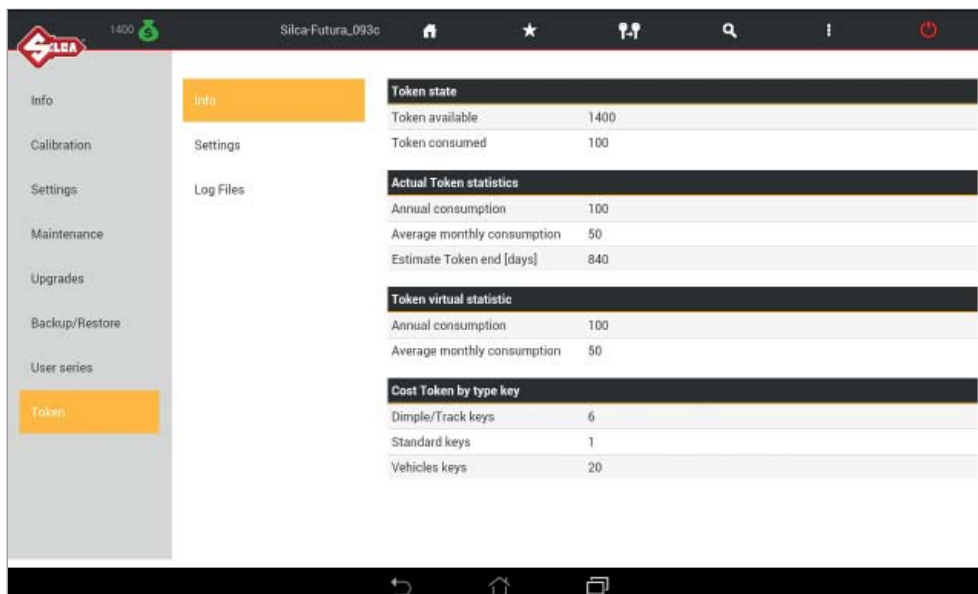

| Token state | |
|-----------------|------|
| Token available | 1400 |
| Token consumed | 100 |

| Actual Token statistics | |
|-----------------------------|-----|
| Annual consumption | 100 |
| Average monthly consumption | 50 |
| Estimate Token end [days] | 840 |

| Token virtual statistic | |
|-----------------------------|-----|
| Annual consumption | 100 |
| Average monthly consumption | 50 |

| Cost Token by type key | |
|------------------------|----|
| Dimple/Track keys | 6 |
| Standard keys | 1 |
| Vehicles keys | 20 |

“Real statistics” are calculated according to the actual consumption of the tokens purchased (when normal tokens are used).

“Virtual statistics” calculate average consumption of tokens when a UTP is in use. In this way customers can see how much they would have consumed in tokens if they had purchased individual tokens instead of the UTP option.

Tap “**Settings**” to edit the following values:

- **Token alert threshold (number):** indicates the point in numbers of tokens at which special warning messages are activated.
- **UTP threshold alert (days):** indicates the point in number of days at which special warning messages are activated.

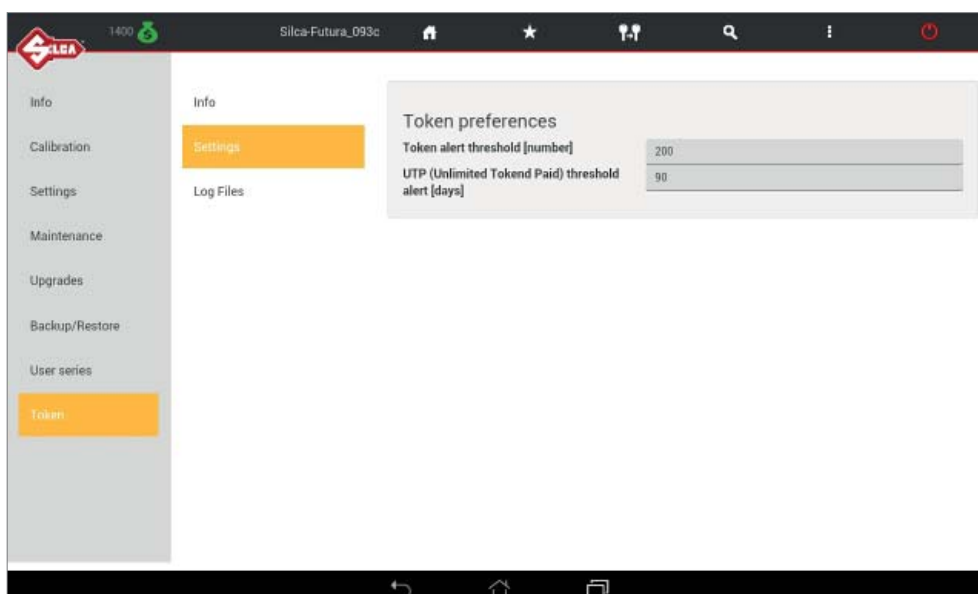

| Token preferences | |
|--|-----|
| Token alert threshold [number] | 200 |
| UTP (Unlimited Tokend Paid) threshold alert [days] | 90 |

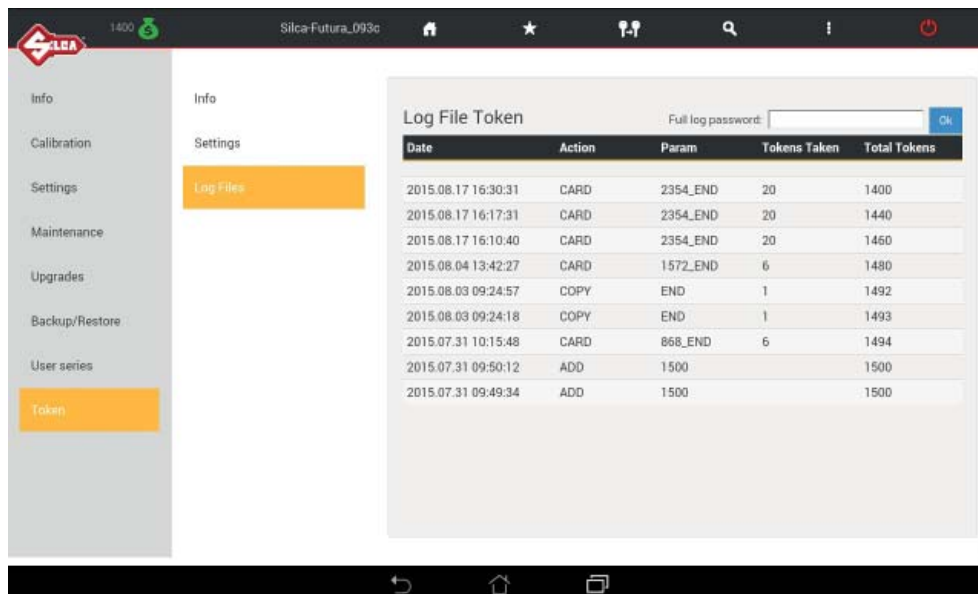

Tap **“Log File”** to view the “last” operations carried out by the machine and saved in chronological order: token recharge; tokens consumed by a copy from the original; tokens consumed by a data card or code copy, etc.



14 CHANGING TABLETS

If a new Tablet is to replace the previous one, download/install the Futura APP. and the customized “Silca Keyboard”.

Proceed as follows:

- 1) Connect the tablet <=> FUTURA in ACCESS POINT mode (Ch.7.3.4.a).
- 2) Open the browser CHROME  (the CHROME icon is in the APPS page ) and enter the following addresses:

192.168.0.1/Silca.apk to download the APP

192.168.0.1/SilcaKeyboard.apk to download the keyboard



- 3) Tap the center bottom “Open all Apps screen” icon 



4) Select "Downloads" from the tablet "Settings" menu .

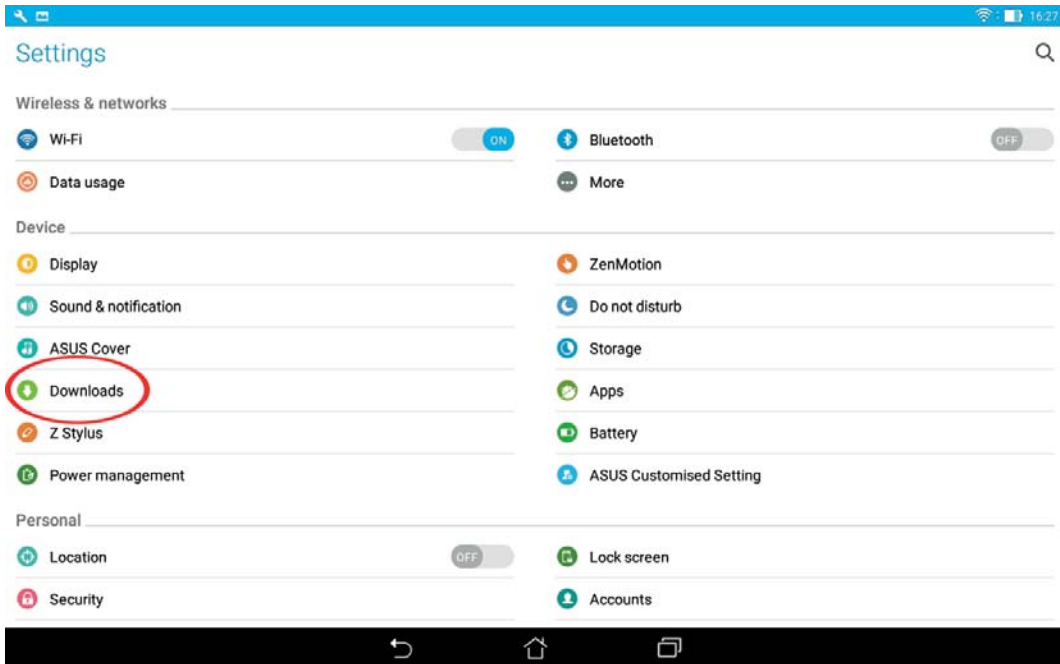

5) Tap on the 2 apps just downloaded for installation.

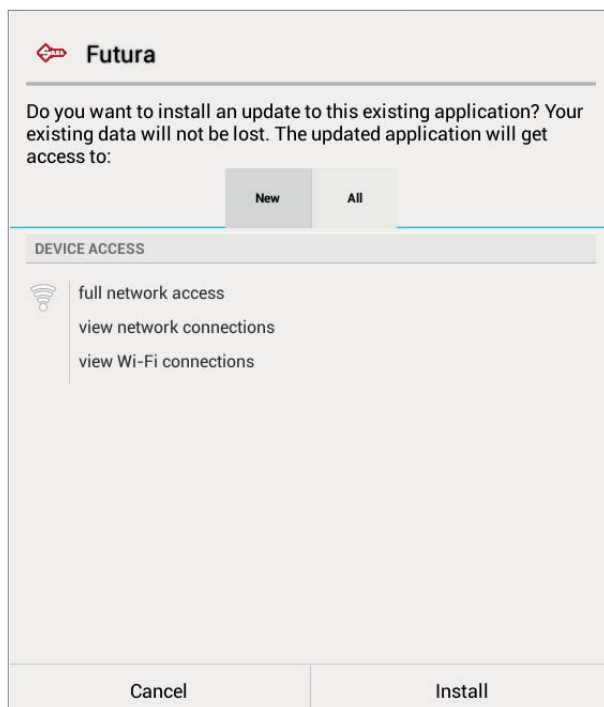

After you install the new FUTURA APP you should move the Silca FUTURA application icon  to the main screen:

- 1) Tap the center bottom “Open all APPS screen” icon 



- 2) Search for “Futura” icon 

- 3) Tap and hold (keep pressing) the Silca Futura application icon and drag it to the main screen.

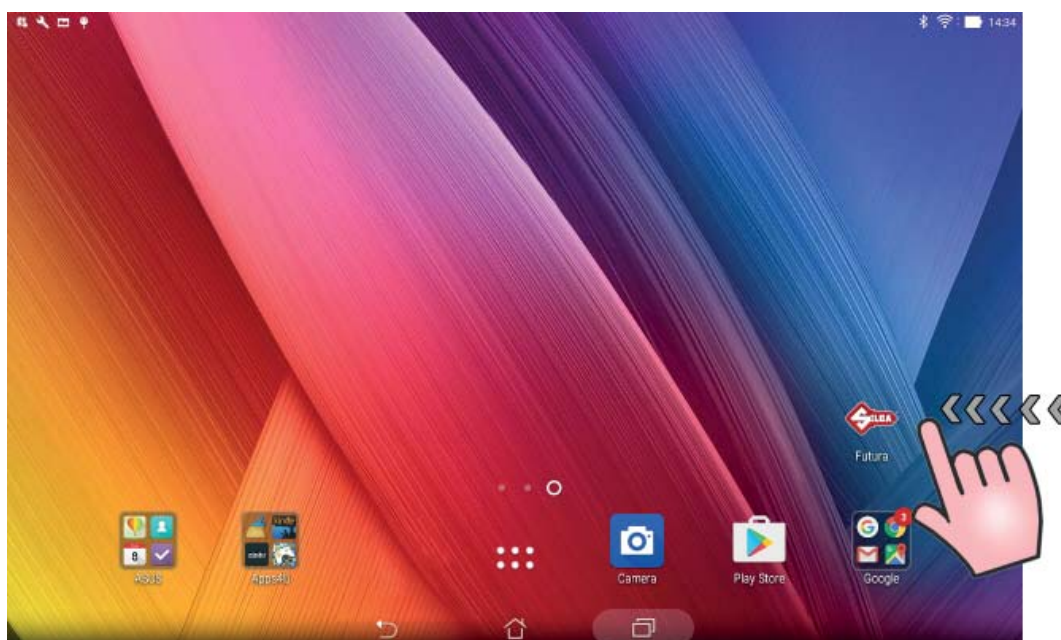

15 FUTURA PROCEDURE TO CLEAR CACHE

Clearing the FUTURA APP Cache is recommended to improve the performance of the FUTURA APP.

1) Entering the Android Tablet Settings .

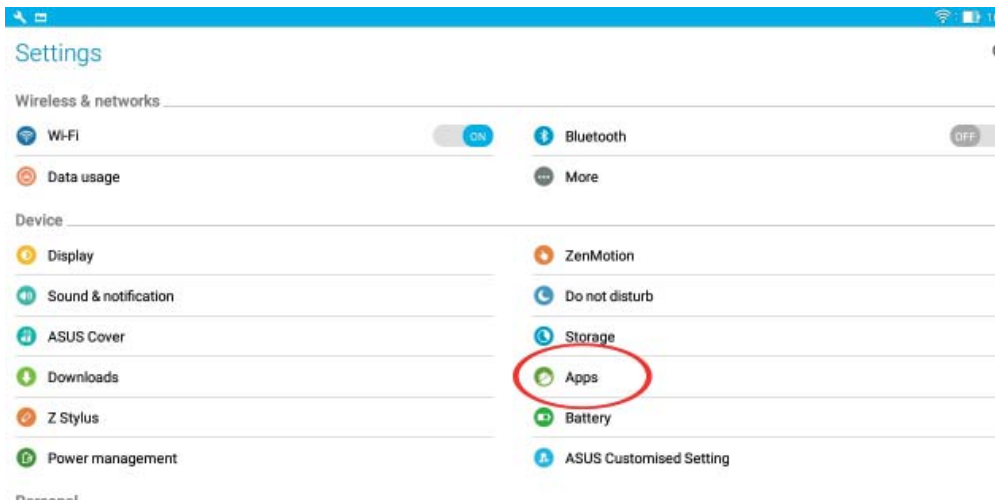

2) Tap on “APPS” and then “FUTURA”.



3) Tap on “Clear Cache”.

