



Steering Column to Steering Box  
*Installation Instructions*  
for Tri-Five Chevrolets

**Right Hand Drive Steering Column**



## Thank you for purchasing the Tri-Five Chevy column from ididit.

This is a simple overview of how to mount your column. Any steering column must be secured at the dash and firewall. This column will use all the original mounting brackets at the dash. If you are missing parts, some are available from Ecklers, or Danchuck. Both have web sites to visit if necessary.

In these instructions we assume either the original gear box or an aftermarket box are mounted in the original position. Since the gear box is so close to the firewall, only a coupler (manual) or rag joint (power) are necessary. If you have done a frame off restoration, the distance may have changed between the body and the frame. Remember, the steering column is one of the few parts that relate to both body and chassis. If the body is placed slightly back from the original position, you may need to add an inch to the column. We will be happy to exchange this column (in original condition). *We cannot be responsible for body placement.*

If you have added a rack and pinion front end, the installation will require 2 joints and a shaft to reach the rack. This would be more of a “hot rod” installation than a restoration. Both are great additions to updating your steering.

It is highly recommended that you fit your column before painting it. Test fitting now will save you a headache later on. *We are not responsible for paint.*



## INSTALLATION OF IDIDIT COLUMN IN YOUR TRI-FIVE

### INSTALLATION STEPS FOR 55-56 CHEVY STOCK UNDERDASH MOUNT

Step 1: Slide cluster seal up steering column tube to the upper limit of column.

Step 2: Attach mount to upper dash

Step 3: Place column in designated place and affix mount in position making sure tab of mount is inside column. If no hole is in tube drill hole so tab will align. (Floor shift model has no hole pre-drilled)

Step 4: Install steering column dash cover. (Screw hole marked in Step 3 and 4)



### INSTALLATION STEPS FOR 57 CHEVY STOCK UNDERDASH MOUNT

Step 1: Hold column in mounting positioning and affix column mount to dash. Drill two self tapping screws through column to hold column in place (use a short self tapping screw #8 or #10).

Step 2: Attach U-Bracket to dash

Step 3: Place column dash cover over assembly and screw into U-Bracket.

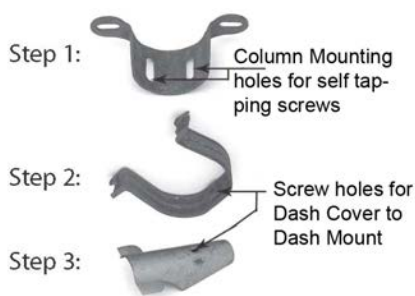

### The Classic Chevy Floor Mount is made up of two pieces:

A.) T-shaped L Bracket

B.) Clamp

The T shaped bracket mounts in the original bolt holes in the inside floor of your Chevy. The long extension comes forward toward the driver. The clamp should slide up the tube of the steering column. The steering column then slides above the extension and through the floor board. The clamp will slide over the extension of the floor bracket and around the column. Tighten

all fasteners when you are comfortable with the installation. Your column is now secured to the floor to prevent any movement.

### Turn Signal Lever:

The turn signal lever is located closest to the top of the column. With the steering wheel and adaptor removed, look down at the top of the column and on the left side you will see a round screw hole. This secures the lever to the column. Insert the lever onto the turn signal switch and insert the provided screw into the screw hole (not D shaped hole). Use a #2 Philips screw driver to tighten the screw until the lever is no longer loose, the screw will not rub on the brass piece of the white horn cam.



### Tilt Lever:

Located directly below the turn signal lever will be the treaded hole for the tilt lever. Simply screw the tilt lever into this hole.



### Emergency Flasher Knob:

The Emergency flasher is threaded into the hole located on the right side of the column. You will noticed the plastic portion that the flasher screws into is flush with the outer surface when the flashers are in the off position. It is easy to accidently turn the flashers ON while installing which could lead to problems later. Check to make sure the flashers are in the OFF position before continuing.



### If Column Shift Application:

Place column shift knob onto the shift lever. Once on, use setscrew (provided) and adjust knob so setscrew is pointing towards the floor, tighten setscrew. Do not remove the upper shift lever for any reason! The tension spring will pop out and it is very difficult to re-install.

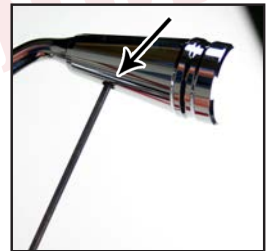

### Column Shift Linkage Installation:

At the bottom of your column you will notice a lever. This is the shift lever where your linkage will attach from the column to the transmission. Note the 5/16 hole through the bushings, most kits use a 5/16 bolt to secure the rod to the column. Please follow the kit instructions for the linkage, but make sure that no part of the kit hits the metal portion of the lever, as it will create a rattle in the column.



## Wiring your Column

This ididit steering column uses a standard 3 7/8-inch male connect. However, some GM columns use a 4 1/4-inch male connector. Connectors do not interchange and must be used in pairs. A mate to the 3 7/8 inch plug is available through ididit. If you need to change this connector for any reason the following schematic will be helpful.

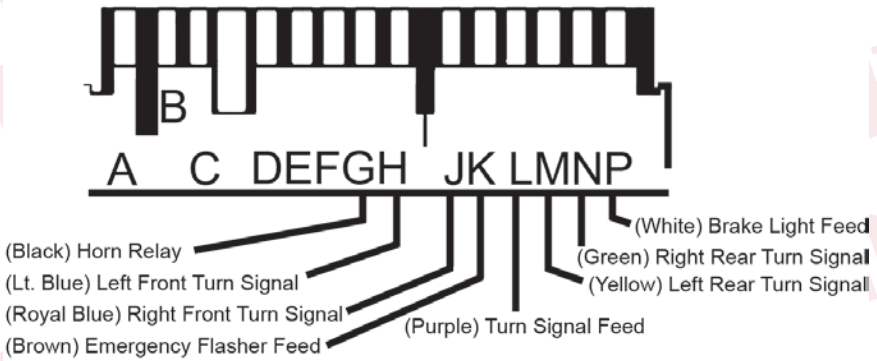

## Horn Button Wiring:

A horn may require two wires to properly function with an ididit column. The center lug on the button should connect to a horn wire, which is provided by ididit with your steering column. This horn wire will slide into the horn cam (white plastic tube sticking up on the top of the column). If there is a second wire off to the side it is probably a ground wire (check with the horn button manufacturer to be sure). This is normally used when an o-ring is used to hold the button in place. The o-ring does not provide sufficient ground, therefore, an additional wire is provided to ground the horn button. If there is not a hole in adaptor to ground to, use one of the puller holes with a short bolt to attach the wire to the adaptor.



## Synchronizing your Column

In order to ensure proper functioning, this steering column must be installed in sync with the rest of the steering system. Signal cancellation and wheel position, as well as smooth steering operation depends on it. Although not all of them may need adjustment, the complete list of steps required for full synchronization is as follows:(*continued on next page*):



1. The front wheels must be pointing straight forward with steering toe set reasonably close.
2. Rotate the steering box input shaft from lock to lock and **set the box exactly half way between**. For example, if the shaft rotates 3 full turns from lock to lock, the center will be at 1-1/2 turns from either locked position.
3. Install steering arm and drag link and **adjust tie rod ends to get the rack to fit without moving either the front wheels**. Rotating each tie rod end the same number of turns will preserve adjustment.

4. With the column mounted in position and both u-joints installed, measure between the u-joints to determine the proper shaft length. Install the u-joints on the shaft so that the bearing cups of both joints will lay flat on a level surface and the angle of the u-joints are equal.

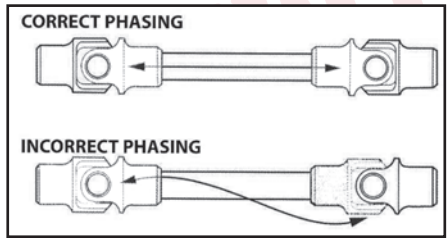

5. Install the shaft on the rack. Leave the upper part of the shaft unconnected for the time being.
6. Position the column housing so that **the signal switch arm is level**.
7. Rotate the steering column shaft so that **the horn connection is at approximately 4:30 from the signal switch arm**.
8. Without rotating the connecting shaft, column housing or steering shaft (except very slightly to catch the nearest spline location) lift the column and slide the upper u-joint onto the lower column shaft.
8. If proper synchronization has been achieved, the finished column installation should look like the diagram below. If this is the case, tighten all fasteners and verify that the signal switch is cancelling properly. You're done!

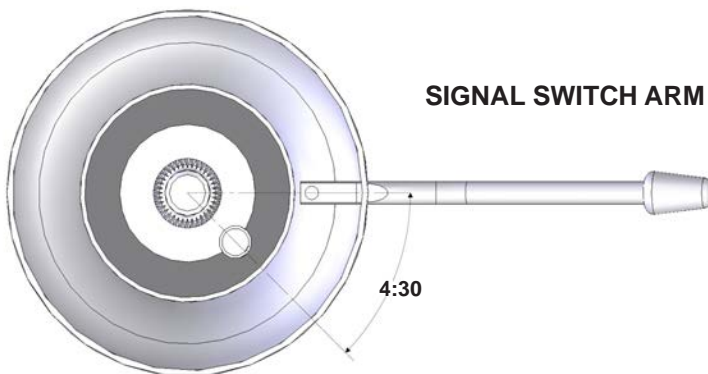

# INSTALLATION INSTRUCTIONS FOR THE CLASSIC 1955-56-57 CHEVY – TILT STEERING WITHOUT COLUMN SHIFT, USING STOCK GEAR BOX

3/4" DD x 1" DD coupler, this coupler will be held to the column with two set screws, installed at a 90° angle to each other.

The coupler is pre-welded the 1" DD side to go on the column, two flat sides ground onto stock 3/4" shaft (coming out of gear box) to make it 3/4" DD to fit into other side of coupler

**TILT COLUMN WITHOUT SHIFTER**

**1" DD SHAFT FROM THE NEW STEERING COLUMN**

**3/4" DD TO 1" ADAPTOR**

**PART #3000315249**

**ORIGINAL STEERING SHAFT  
MADE IN TO A 3/4" DD BY  
GRINDING TWO FLATS.**

Cut approximately 6" up from the box and work your way down until the column is properly positioned in your dash. (See "Synchronizing Your Column" on page 7.)

# INSTALLATION INSTRUCTIONS FOR THE CLASSIC 1955-56-57 CHEVY – TILT STEERING WITH COLUMN SHIFTER, USING STOCK GEAR BOX

A 3/4”-36 x 3/4” DD coupler will be held to the column with set screws. The 3/4”-36 end will fit on the column shaft.

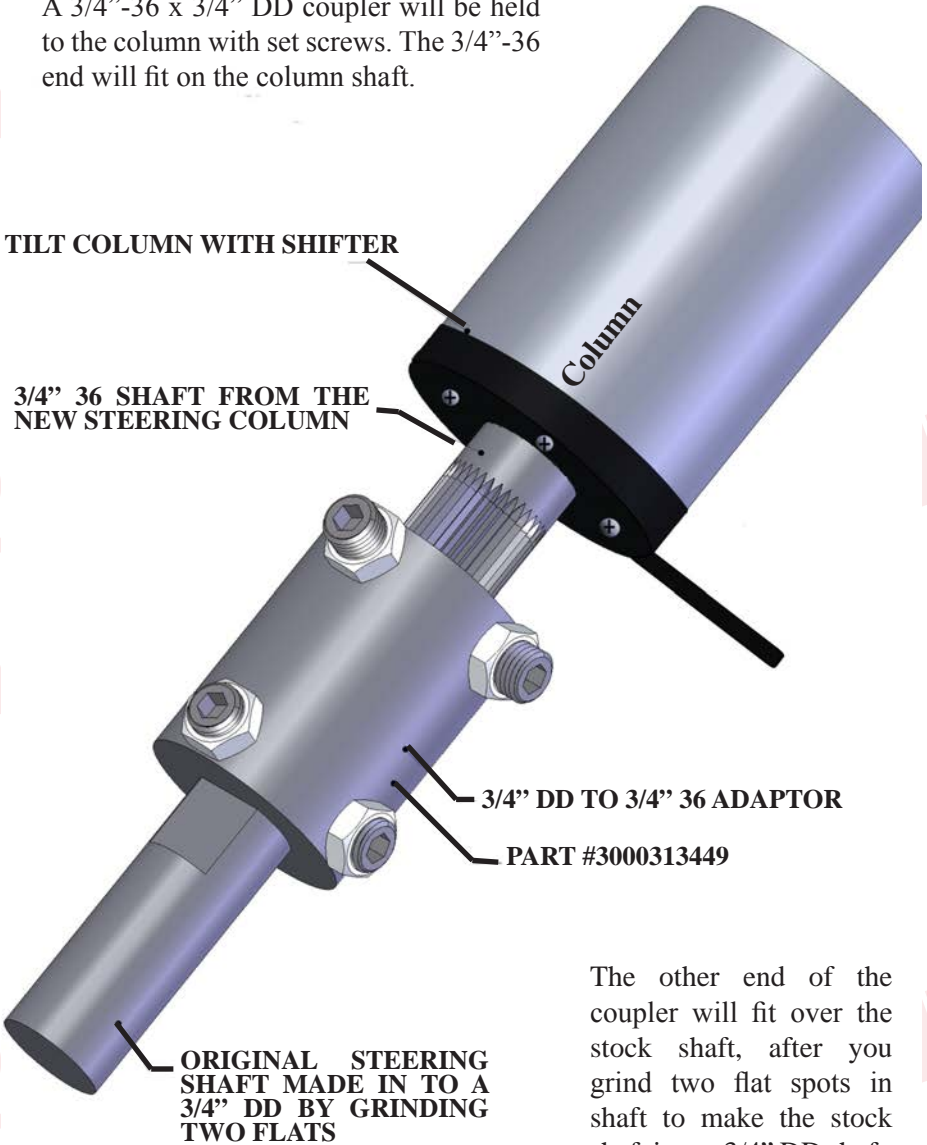

The other end of the coupler will fit over the stock shaft, after you grind two flat spots in shaft to make the stock shaft into a 3/4” DD shaft. (See “Synchronizing Your Column” on page 7.)



# INSTALLATION INSTRUCTIONS FOR THE CLASSIC 1955-56-57 CHEVY – TILT STEERING WITH COLUMN SHIFTER TO THE 605 STEERING BOX

Once you have the box mounted in position, a rag joint is used to connect it to your new column. This is a direct hook-up. This column uses a 3/4" 36 shaft so a 3/4" 36 3/4" 30 splined rag joint is used. Both shafts are secured to the rag joint with the supplied set screws.

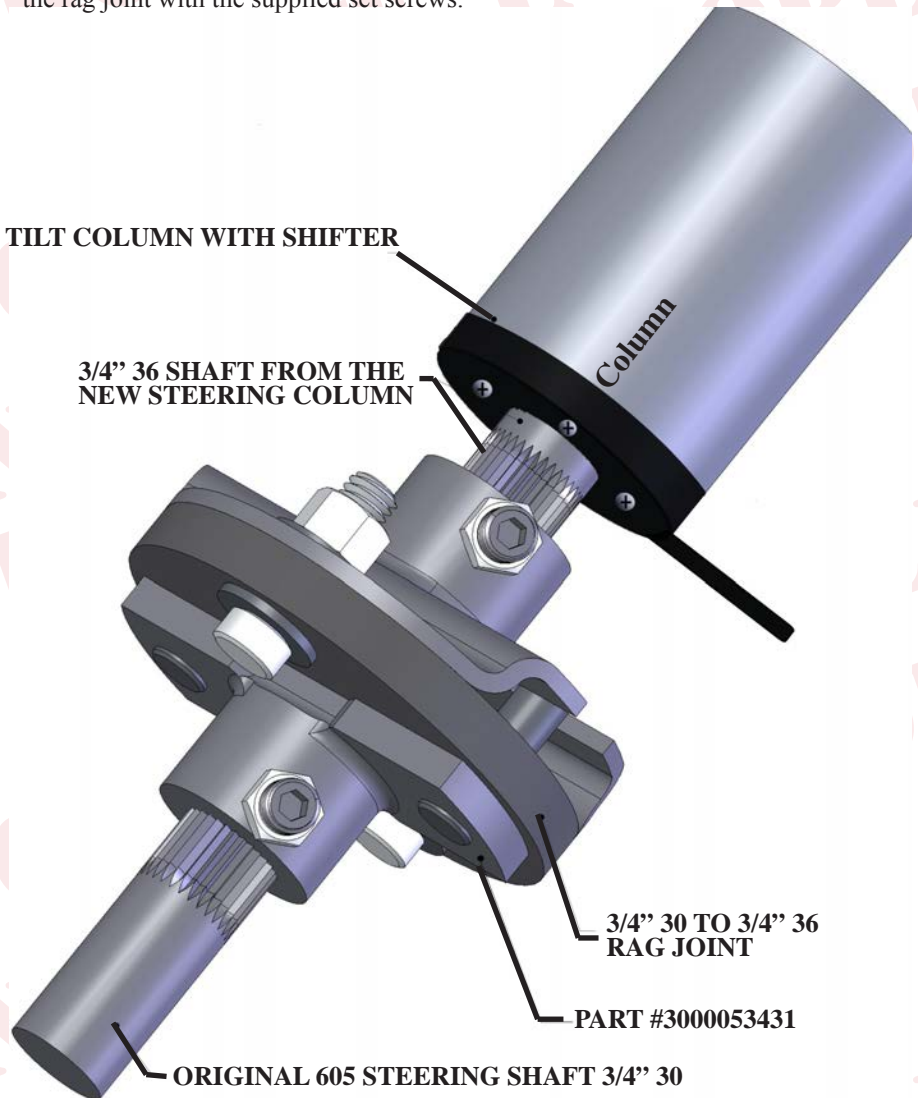

# INSTALLATION INSTRUCTIONS FOR THE CLASSIC 1955-56-57 CHEVY – TILT COLUMN TO THE 605 STEERING BOX

Once you have the box mounted in position, a rag joint is used to connect it to your new column. This is a direct hook-up. The tilt column uses a 1" DD shaft so a 1" DD x 3/4"-30 splined rag joint is used. Both shafts are secured to the rag joint with the supplied set screws.

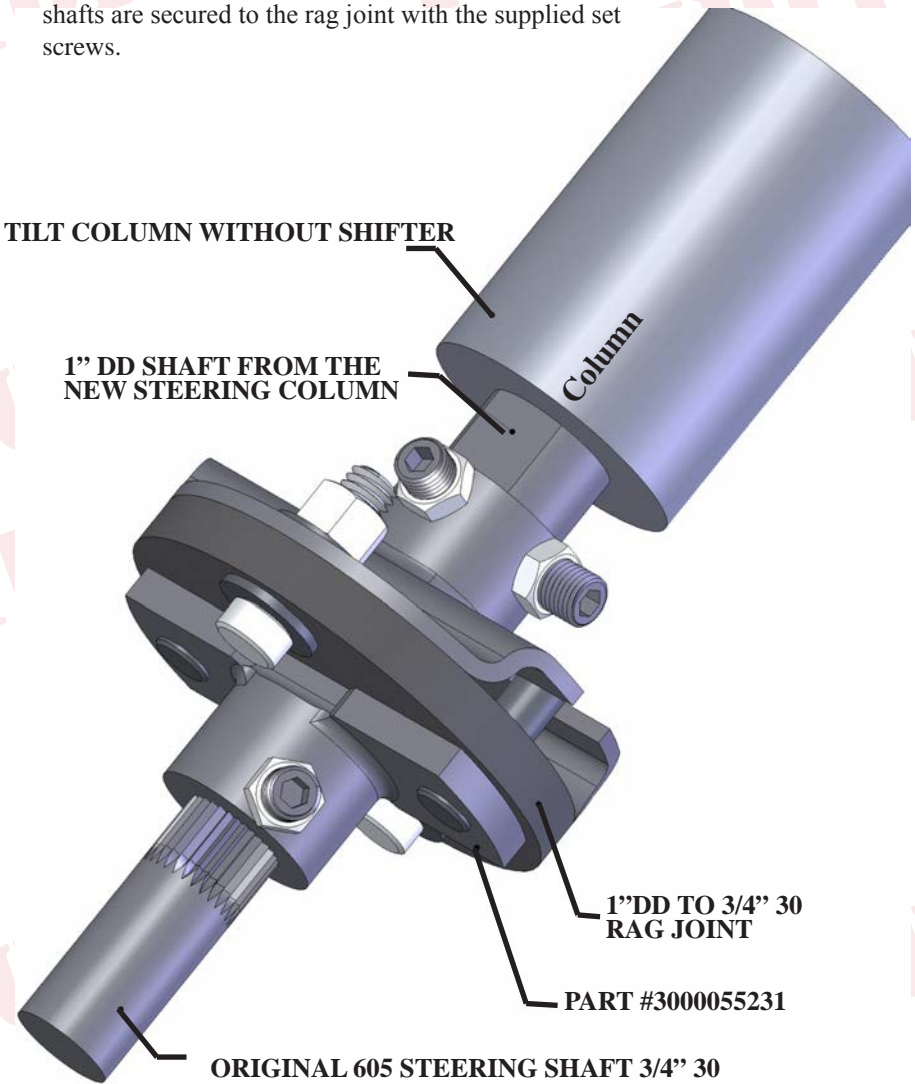

These are the parts that will correspond to the particular installation that you are doing. This will speed up the ordering process when the time comes.

#3000315249	3/4" DD x 1" DD Coupler
#3000313449	3/4" 36 Spline x 3/4" DD Coupler
#3000055231	1" DD x 3/4" 30 Spline Rag Joint
#3000053431	3/4" 36 Spline x 3/4" 30 Spline Rag Joint
#2612000010	'55-57 Horn Kit
#2612100040	'55-57 Horn Kit with Ring

## STEERING WHEEL MODIFICATIONS FOR 1955-56-57 CHEVYS WITH STOCK STEERING WHEEL MOUNTED ON STEERING COLUMN



The spline in your stock steering wheel is the same as the one on the new column, so no modifications are needed here.

Turn the wheel over and find two screws that hold a metal tab to the wheel. This tab is what is used to cancel your turn signals. Remove the two screws and the tab as you will not be using them with your new column.

if purchased. If the horn kit with ring is purchased, the ring is to be siliconed onto the steering wheel. If it doesn't fit on exactly right, use a file or die grinder to trim inside.

You will have to drill a 1/2" diameter hole in the wheel 3/4" from the center of the splined hole in the center of the steering wheel at 4:30 (looking at

the front of the wheel). If this can't be done because of screw holes for a puller, try to get the hole as close as possible on either side. Do not drill out puller holes, you may need them later to pull the wheel. Install horn kit, if purchased. If the horn kit with ring is purchased, the ring is to be siliconed onto the steering wheel. If it doesn't fit on exactly right, use a file or die grinder to trim inside.

Next, install the wheel on the column. If it doesn't want to go on at first, move the horn cam with your thumb and index finger a little one way or the other until the wheel drops down fully. This horn cam is what cancels the turn signals, so with this horn cam at 4:30, the steering box half way between full left and right, and the road wheels pointed straight ahead, the turn signals will cancel at the right time.

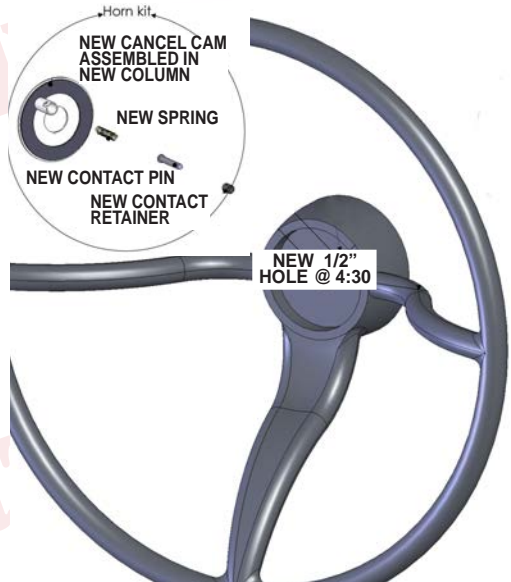

# STEERING COLUMN AND WHEEL ADAPTOR COMPARISONS

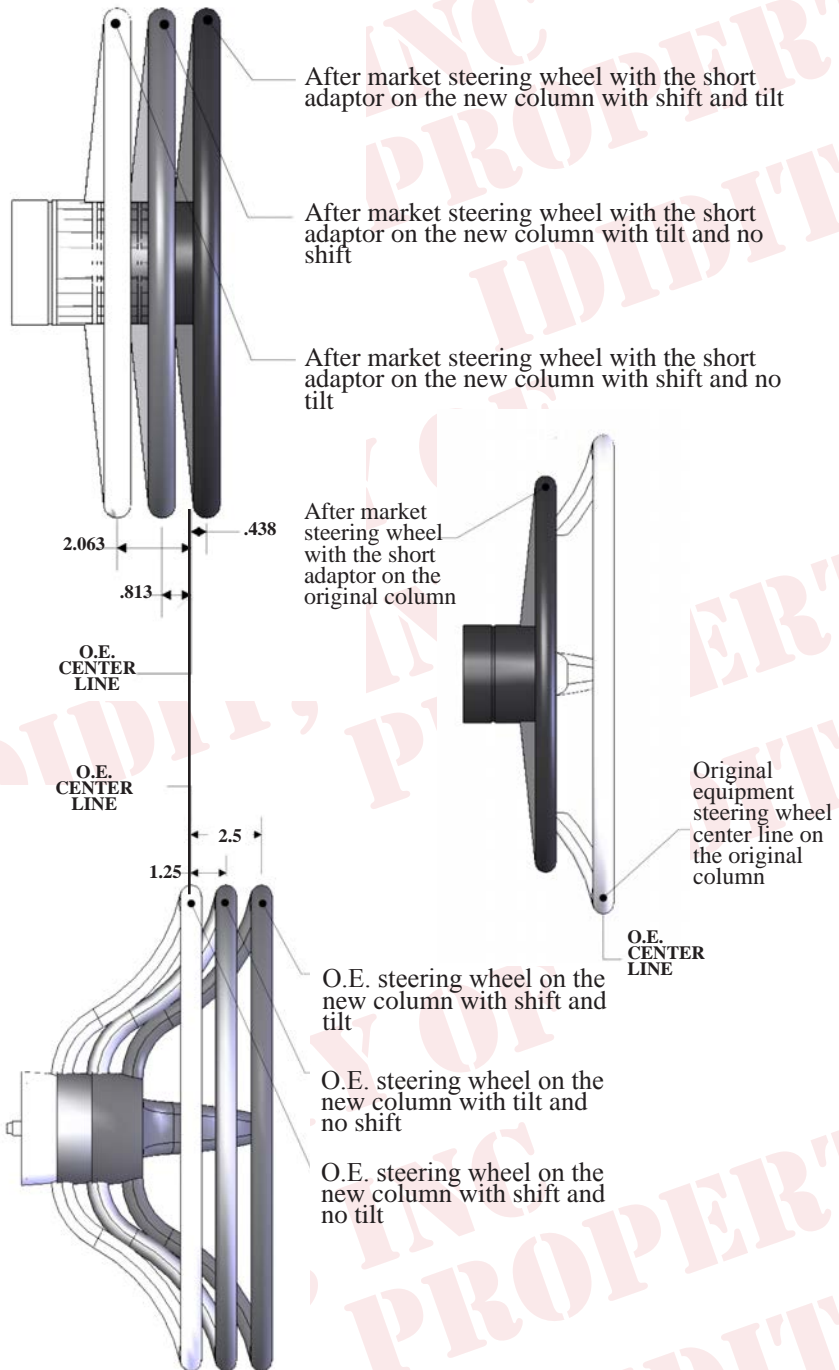

Style A.



Style B.



## WIRING FOR NEUTRAL SAFETY SWITCH

THERE ARE TWO DIFFERENT STYLES

Style A. The two tabs on the Left side of the neutral safety switch control the actual starting of the engine.

Hook the solenoid wire from the ignition switch to the top tab on the left side of the neutral safety switch. Connect a wire from the bottom tab to the starter solenoid marked with the letter "S". The neutral safety switch has been pre-adjusted. If you remove the switch to paint the column, you may have to adjust it so it will only start in park and neutral again.

Style B. The two tabs on the Right side of the neutral safety switch control the actual starting of the engine.

Hook the solenoid wire from the ignition switch to the top tab on the right side of the neutral safety switch. Connect a wire from the bottom tab to the starter solenoid marked with the letter "S". The neutral safety switch has been pre-adjusted. If you remove the switch to paint the column, you may have to adjust it so it will only start in park and neutral again.

The other two tabs are for back-up lights. One tab goes to a fuse that is hot all the time. The other tab goes to the back-up lights. If no back-up lights are to be used, disregard these directions and hook no wires to either tab.

### **Accessories Important to Installation:**

**#2401400010**

**Classic Chevy Floor Mount**

This floor mount bolts through the floor in the original holes. It stands up off the floor within the original floor mount opening. Quick and easy installation.

**#3100035785**

**1957 Chevy Wiring Adaptor for stock wiring**

**#3100035780**

**1956 Chevy Wiring Adaptor for stock wiring**

**#3100035775**

**1955 Chevy Wiring Adaptor for stock wiring**

*These are wiring harness adaptors from the plug on the steering column to the original plug under the dash. They change the configuration and have a flasher installed to convert your parking lights to four way flashers. They are YEAR sensitive...be sure to order the correct year for your vehicle!*