

1997-2005 Buick Century • 1997-2004 Buick Regal • 1998 Buick Regal GS
2000-2011 Chevrolet Impala Sedan • 2000-2007 Chevrolet Monte Carlo
1997-2003 Pontiac Grand Prix • 1998-2001 Pontiac Grand Prix GTP
2005-2009 Buick Allure • 2005-2009 Buick LaCrosse



This product is intended to replace the existing suspension components with a passive coil and shock system. The system has been designed and extensively tested to provide the same ride quality and height as O.E.M.



These instructions do not replace a certified mechanic. If you do not feel comfortable working on your car, please take these parts to a certified mechanic for installation.,

General Precautions

When servicing any vehicle be sure to follow all safety procedures.

First, make sure that when lifting the vehicle that you are using the appropriate jack for the weight of the vehicle.

Make sure before going underneath any vehicle that it is properly supported with sturdy jack stands and on level ground so that the vehicle doesn't fall or slide off of the jack and onto you.

As with any automotive repair, make sure you have the appropriate tools to do the job so you don't damage any parts on the vehicle. There is a list of tools needed included in these instructions.

Safety glasses and mechanic gloves should also be worn for your protection.

Be sure to follow the instructions in the order that they are given. The instructions are in a certain order for a reason and improper installation could lead to damage to your vehicle or the parts. Keep in mind that if you damage the parts during installation you will be responsible for the replacement parts

Product Photos



Minimum Tools Needed For This Installation



Metric Hand Tools (Sockets/Wrenches)



Jack and Jackstands



Screw Drivers (Phillips and Flat Head)



Grease Pencil



WARNING

Lift the vehicle using **ONLY** a frame-contact vehicle lift. Do **NOT** lift the vehicle using a suspension-contact vehicle lift.

CAUTION

Complete strut assemblies are delivered completely assembled. Removal of any components or alteration of the unit will result in a void of warranty and may cause physical harm

Removal

1. Remove the strut-to-body mount nuts (1).
2. Raise and support the vehicle.
3. Remove the tire and wheel assembly.
4. Remove the stabilizer shaft link from the strut. (2)
5. Remove the bolt (3) from the brake hose bracket (4) and the strut assembly.
6. Scribe the strut to the knuckle. (5)

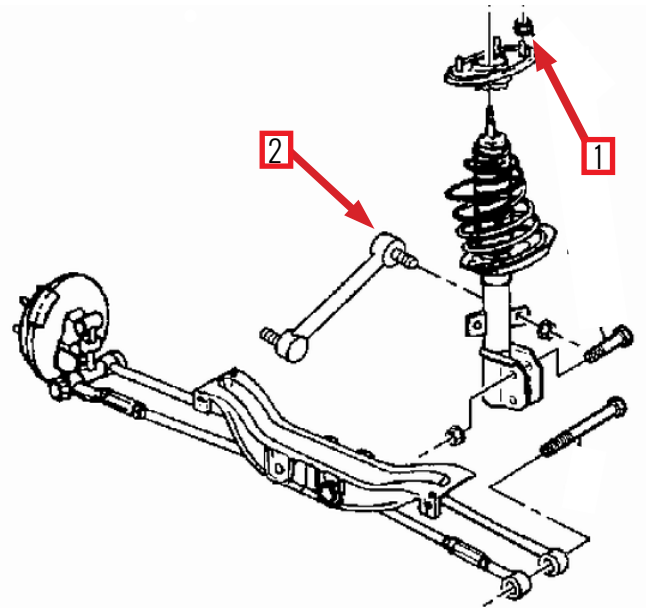

Notice: The knuckle **must be** retained after the strut-to-knuckle bolts have been removed. (6) Failure to observe this may cause ball joint and/or wheel drive shaft damage.

7. Remove the strut to knuckle bolts.
8. Remove the strut from the vehicle.

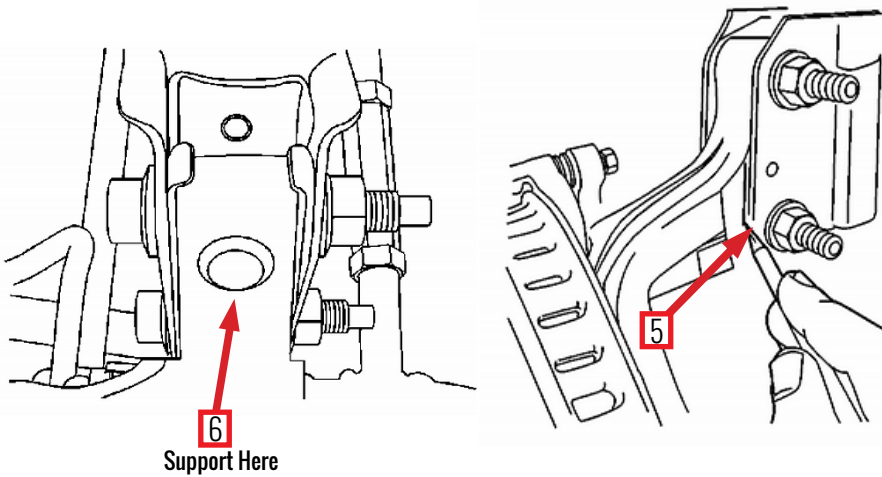
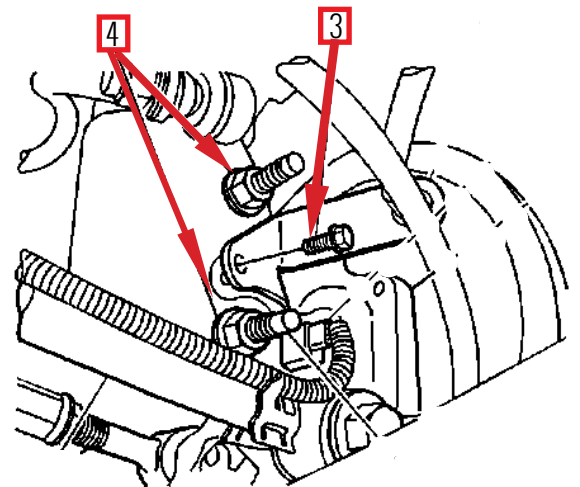

Installation



Notice: Care should be taken to avoid chipping or scratching the coating when handling the suspension coil spring. Damage to the coating can cause premature failure.

1. Install the strut into place.
2. Install the strut to knuckle bolts.
Tighten the strut to knuckle bolts and nuts to 120 Nm (89 ft. lbs.).
3. Install the bolt (2) to the brake hose bracket (3) and the strut assembly.
Tighten the bolt to 27 Nm (20 ft. lbs.).
4. Connect the stabilizer shaft link to the strut.
5. Install the tire and wheel.
6. Install strut to body mount nuts (1).
Tighten the strut to body mount nuts to 45 Nm (33 ft. lbs.).
7. Lower the vehicle.
8. Adjust the rear wheel alignment.

