

PART #	DESCRIPTION
95121	2017-UP FORD F150 RAPTOR HYDRAULIC REAR BUMP STOP KIT

COMPONENTS INCLUDED	
(2) 204907 BUMP STOP ASSEMBLY (1) 190011 ABS VENT BRACKET (1) 197030 BUMP STOP CROSS BAR (2) 194031 BUMP STOP TENSION RODS (1) 194020 BUMP STOP MOUNT (DRVR) (1) 194021 BUMP STOP MOUNT (PASS) (1) 194022 INSIDE BUMP STOP MOUNT (DRVR)	(1) 194023 INSIDE BUMP STOP MOUNT (PASS) (2) 194024 STRIKER PLATE (2) 194025 BUMP STOP NUT PLATE (1) 194026 TENSION MID PLATE (FRONT) (1) 194027 TENSION MID PLATE (REAR) (2) 194028 STRIKER NUT PLATE (1) 95121H 17-UP RAPTOR BUMP HARDWARE KIT
HARDWARE INCLUDED	
95121H HARDWARE KIT	
(2) 169003 SLEEVE .750 X .510 X .250 (2) 194028 REAR BUMP STRIKER NUT TAB (2) 209003 SLEEVE 2.25 X 2.010 X 1.00 (2) 295523 KMXL8 LEFT HAND ROD END (2) 295524 1/2-20 CLEVIS .25 SLOT X .38 HOLE (4) 605052 1/4-20 NYLOCK NUT (4) 605057 1/4-20 X 2.000 HHCS (2) 605090 5/16-18 X .750 FHSCS 18-8 SS (2) 605108 3/8-16 X 1.250 HHCS (2) 605121 3/8-16 NYLOCK NUT (4) 605133 3/8" FLAT WASHER	(8) 605302 1/2-13 X 1.500 HHCS (2) 605304 1/2-13 X 2.250 HHCS (6) 605306 1/2-13 X 2.500 HHCS (4) 605314 1/2-13 X 4.250 HHCS (18) 605321 1/2-13 NYLOCK NUT (42) 605330 1/2" FLAT WASHER (4) 605342 1/2-13 X 2.75 HHCS FULL THREAD (2) 605355 1/2-20 JAM NUT THIN (2) 605356 1/2-20 LEFT HAND JAM NUT (2) 605970 VIBRATITE ANTI SEIZE TUBE (2) 605860 M8 X 1.25 X 30MM FLANGE BOLT
TOOLS REQUIRED	
JACK JACK STANDS TORQUE WRENCH 3/4" SOCKET / WRENCH 7/16" SOCKET / WRENCH 5/32" ALLEN WRENCH	9/16" SOCKET / WRENCH 10MM SOCKET / WRENCH 13MM SOCKET / WRENCH 15MM SOCKET / WRENCH 16MM SOCKET / WRENCH 18MM SOCKET / WRENCH
TECH NOTES	
1. YOUR ICON BUMP STOP ASSEMBLIES COME FACTORY CHARGED TO 150 PSI. PLEASE CONSULT ICON PRIOR TO MAKING ANY NITROGEN PRESSURE CHANGES.	
2. ICON BUMP STOP KIT WORKS WITH OEM RAPTOR REAR SHOCKS AND LEAF SPRINGS.	
3. MAKE SURE THAT THE BUMP STOP SPACER RING IS INSTALLED (REFER TO DIAGRAM). FAILURE TO INSTALL RING WILL CAUSE DAMAGE THAT IS NOT COVERED UNDER ICON'S WARRANTY POLICY.	

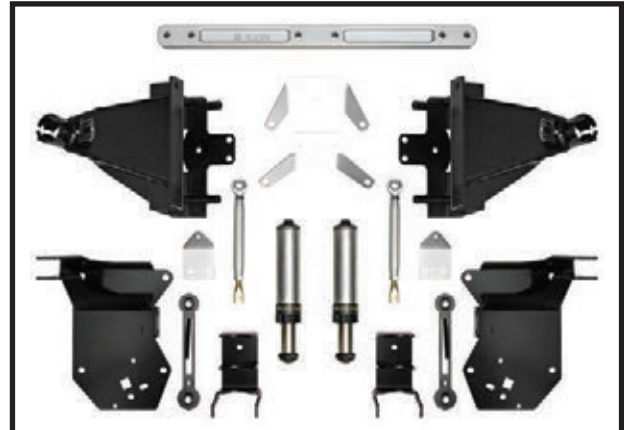

**WARNING!**

**\*\* READ ALL INSTRUCTIONS THOROUGHLY FROM START TO FINISH BEFORE BEGINNING INSTALLATION! IF THESE INSTRUCTIONS ARE NOT PROPERLY FOLLOWED SEVERE FRAME, SUSPENSION AND TIRE DAMAGE MAY RESULT TO THE VEHICLE!**

**\*\* ICON VEHICLE DYNAMICS RECOMMENDS THAT YOU EXERCISE EXTREME CAUTION WHEN WORKING UNDER A VEHICLE THAT IS SUPPORTED WITH JACK STANDS.**

**\*\* ICON VEHICLE DYNAMICS RECOMMENDS ALL INSTALLATION TO BE PERFORMED BY A PROFESSIONAL SHOP/SERVICE TECHNICIAN. PRODUCT FAILURE CAUSED BY IMPROPER INSTALLATION WILL NOT BE COVERED UNDER ICON'S WARRANTY POLICY.**

## INSTALLATION

1. Remove the spare tire from underneath the bed, refer to the factory service manual for removal procedure. This is best done on the ground before placing the vehicle on jack stands.
2. Using a properly rated jack, raise the rear of the vehicle and support it with jack stands under the frame rails. Remove wheels and slowly lower the suspension to full extension.
3. Remove the factory bump stops. Twist and pull outward on the rubber bump stop to release it from the cup. Remove the bolt and bump stop cup, save the factory hardware. [FIGURE 1 & 2]

FIG.1



FIG.2



4. Move brake line bracket and wire harness on the driver side. Nothing needs to be disconnected just pushed out of the way. Remove the bolt holding the brake line bracket to the inside of the frame. Using a panel clip tool or large flat screwdriver, pop the plastic retaining clips out of the inside and top of the frame rail. You can now flex the lines and harness away from the inside of the frame. [FIGURE 3 & 4]

FIG.3



FIG.4



5. Move the exhaust on the passenger side of the vehicle. Loosen the exhaust clamps forward of the muffler. Remove the exhaust hangers just rear of the axle on both sides. Remove the two bolts from the rear exhaust hanger where it attaches to the bumper on each side, set aside for reinstallation later. The exhaust can now drop down out of the way to allow for bracket installation. A bungee or strap can be used to help support some of the weight in the lowered position. [FIGURE 5 - 8]

FIG.5



FIG.6

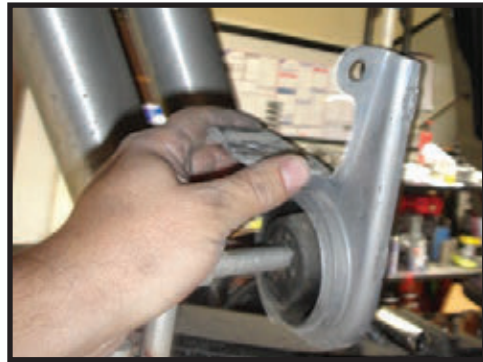

FIG.7



FIG.8



6. To clear the crossmember the exhaust will need to be positioned rearward. This is done by sliding the rear half of the exhaust out of the slip joint at the clamps by 3/4". [FIGURE 9 & 10]

FIG.9

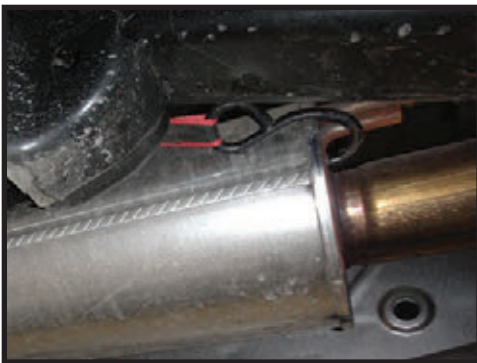

FIG.10





**7.** Inspect the frame, some factory welds may protrude above the frame surface. For ideal fitment you may need to sand the welds so that the surfaces meet well. Use rust inhibiting spray paint to cover any bare metal surfaces. When installing the bracketry system it is best to leave hardware loose until all hardware is partially threaded to assist in fitment. Raptors that have been driven hard off-road often experience some degree of frame damage just above the factory bump stop. This bump system can tolerate some frame distortion and still install well and align correctly but it may be necessary to leave some hardware very loose or slowly tighten hardware to pull the bracketry into place. [FIGURE 11 & 12]



FIG.11



FIG.12

**8.** Refer to the following illustration for correct bolt location and direction.

**9.** Position the outer bump stop brackets (PN: 194020, 194021) on the frame.

**10.** Position the nut plate on the inside of the frame with the arrow pointing toward the front of the truck. Pass the long end of the nut plate through pocket on the inside of the frame. Holding the handle, rotate the rest of the nut plate into the frame and position behind the holes in the frame. Install (2) 1/2" x 2.75" fully threaded bolts with washers through bracket and into the nut plate. Just start the threads a couple of turns. With the bolts started in the nut plates, pull the bump stop brackets back away from the frame so that the lower bolt tab of the bracket does not protrude past the inside surface of the frame rail [FIGURE 15]. This will allow room for the rest of the inner brace components to be installed. [FIGURE 13 - 16]



FIG.13



FIG.14

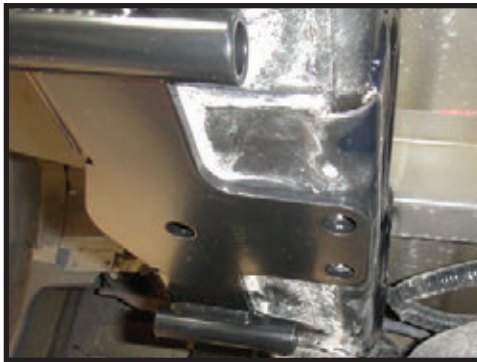

FIG.15

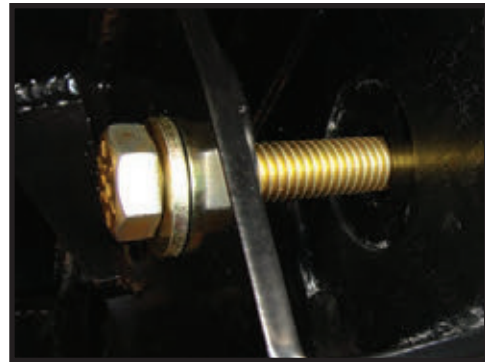

FIG.16

**11.** Preinstall the two mid plates (PN: 194026, 194027) on the billet crossmember with (2) 1/2"x 2.75" bolts and washers so that the head of the bolts points towards the front of the truck. [FIGURE 17 & 18]

FIG.17

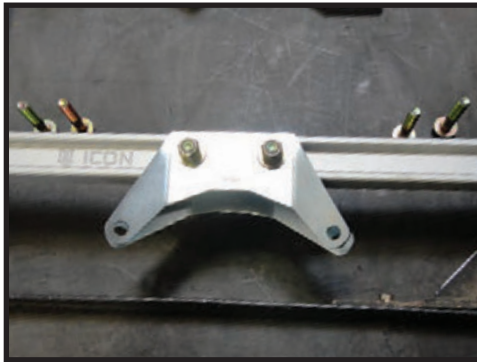

FIG.18



**12.** Install the inner brackets (PN: 194022, 194023) and the crossbar. All the crossbar bolts must go in from the front of the brackets (head of the bolts towards the front of the vehicle) to adequately clear the bed. Position the passenger side bracket over the exhaust and 2" lower than the underside of the bed. Insert the crossbar in the bracket tabs and slide (2) 1/2" x 2.75" bolts through the holes. Connect the driver side bracket to the other end of the crossbar in the same manner. This assembly is awkward to maneuver, an extra set of hands helps. You can now lift the components up into position under the bed and slide the outer brackets on each side inward to help support it. [FIGURE 19 & 20]

FIG.19



FIG.20



**13.** As you slide the outer brackets into position on the frame, make sure the nut plate is located correctly inside the frame with its locating washer on the rearward hole. You can snug up the fully threaded bolts to make sure it stays in place but do not tighten them. [FIGURE 21 & 22]

FIG.21



FIG.22

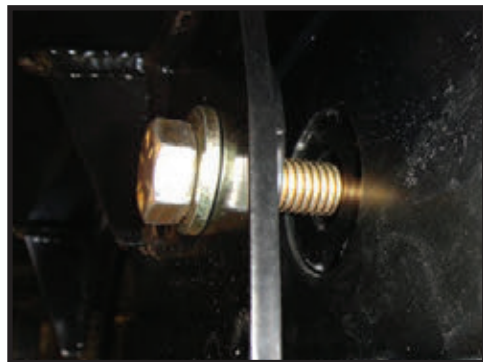

**14.** Install (2) 1/2" x 1.5" bolts with washers in the upper holes over the top of the frame on each side. The forward bolt goes into welded nut on the inside of the bracket. The rearward bolt uses a washer and nylock nut on the inside. Install (2) 1/2" x 4" bolts and washers on each side through the outer bracket tubes and through the inner bracket, secure with washers and nylock nuts. [Torque 6 bolts to 78 ft-lbs]. Install the factory bolt that was removed from the bump stop through the hole in the bottom. [FIGURE 23]

FIG.23





**15.** Assemble the tension rods: Each tension rod gets a clevis on one end and a rod end on the other. The clevis is right hand threaded but the rod end is left hand threaded. Left hand threads are identified by a notch on the hex of both the jam nut and the tension rod. Thread the jam nuts on the rod end and clevis then thread them into the tension rod. Adjust to approximately 9.75" eye to eye, make sure equal amount of thread is exposed on both sides. [FIGURE 24]

FIG.24



FIG.25

**16.** Install the tension rod strut tabs on each side. IMPORTANT: on the driver side the tab goes ABOVE the tabs on the inner and outer bracket and on the passenger side it goes BELOW the tabs on the inner and outer bracket. Secure with (2) 1/2" x 1.25" bolts, washers, and nuts on each side. [FIGURE 26 & 27]

FIG.26



FIG.27

**17.** The crossmember is in slotted holes. Center it left to right and tighten the (4) bolts to 78 ft-lbs.

**18.** Install the tension rods. Adjust to length until the holes line up. Install the 3/8" x 1" bolt, washers, and nut at the clevis. Install the 1/2" x 1.75" bolt, washer, and nut at the rod end with supplied spacer in front of the rod end [FIGURE 25]. Make sure the jam nuts are backed up away from the tension rod then turn the rod to take up the slack, rotate the rod an additional 1/2 turn with a wrench to pretension and stabilize the bracketry system. Tighten, 3/8" to 45ft-lbs, 1/2" to 78ft-lbs, and jam nuts to 54ft-lbs using a wrench on both the jam nut and rod so as not to twist the rod end.

**19.** Replace exhaust hangers. It is common for the rubber in the hangers to compress over time. It may be necessary to bend the rods that go through the hangers to position the exhaust higher for clearance to the strut rods.

**20.** Install the bump stops. Apply anti-seize to the inside of the bump stop mount, slide the 1" spacer ring over the bump stop, then slide the bump stop up into the mount. Install the 1/4" bolts and nuts in the mount's pinch tubes and tighten. Do not over tighten the pinch bolts or the bump stop could bind and not fully extend. [FIGURE 28 & 29]

FIG.28



FIG.29

**21.** Install the striker pads on the axle tube. Pop the ABS clip from the tab on the axle tube. The lower portion of the striker plate hooks under the leaf spring pad on the axle. The slot where the ABS tab was will need to be opened up for the bolt that will secure the striker. Standard drill bits will tend to catch in the oval hole, a die grinder is recommended. Tighten until the pad is in full contact with the axle tube but do not overtighten. [FIGURE 30 - 33]

FIG.30



FIG.31



FIG.32



FIG.33



**22.** Install ABS clip in the striker nut plate. The clips will need to be repositioned to allow slack in the ABS wire. Slide the rubber grommets in the clip and the next closest clip under the leaf spring, use lube or soapy water to ease sliding them. [FIGURE 34 & 35]

FIG.34



FIG.35



**23.** Install the low profile ABS and vent line bracket. Remove the ABS and grommets from there slots, wire clips and vent hose. Unscrew the vent fitting from the axle and remove bracket. Install the low profile bracket with the factory vent fitting. Again, you will need to reposition the grommets on the ABS wires. Slide until they can be reinserted in the bracket and make sure there is adequate slack in all parts of the wires. Reinstall the vent hose on the fitting. [FIGURE 36 & 37]

FIG.36



FIG.37





**24.** Reinstall the wire harness and bracket on the driver side inside frame rail with longer supplied 8mm bolt. There is an oval hole in the inner bracket to accommodate the clip that was removed from the top of the frame. [FIGURE 38 & 39]

FIG.38



FIG.39

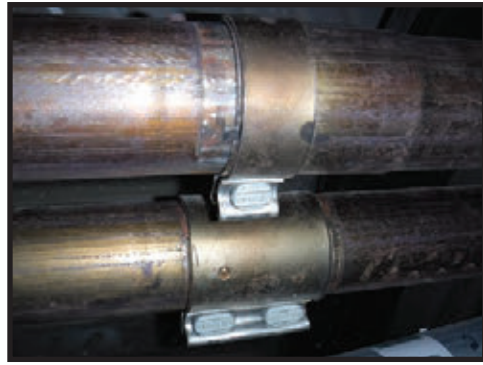

**25.** Confirm that the exhaust has been moved back 3/4" and clears all components. Reinstall the brackets at the middle crossmember in front of the axle and the brackets at the rear bumper. Tighten the clamps where it was slid apart.

**26.** Install wheels and slowly lower vehicle to the ground. Reinstall spare tire.

**27.** After first use, retorquer lower center bolt and the (2) side bolts into the nut plate.

**VERIFY ALL FASTENERS ARE PROPERLY TORQUED BEFORE DRIVING VEHICLE.**

**RETORQUE ALL NUTS, BOLTS AND LUGS AFTER 100 MILES AND PERIODICALLY THEREAFTER.**

ITEM	PN	DESCRIPTION	QTY
1	190005	RAPTOR RR BUMP STRUT TAB	2
2	190011	17+ RAPTOR BUMP ABS VENT BRACKET BLKZINC	1
3	194020	17+ RAPTOR RR AIR BUMP MNT DRVR	1
4	194021	17+ RAPTOR RR AIR BUMP MNT PASS	1
5	194022	17+ RAPTOR AIR BUMP MNT INSIDE DRVR	1
6	194023	17+ RAPTOR AIR BUMP MNT INSIDE PASS	1
7	194024	17+ RAPTOR RR BUMP STRIKER PLATE	2
8	194025	17+ RAPTOR RR BUMP NUT PLATE CZINC	2
9	194026	17+ RAPTOR RR BUMP STRUT MID PLATE FRT	1
10	194027	17+ RAPTOR RR BUMP STRUT MID PLATE RR	1
11	197030	17+ RAPTOR RR BUMP CROSS BAR	1
12	197031	17+ RAPTOR RR BUMP TENSION ROD	2
13	204907	2.0 AIR BUMP 2.5 TRAVEL 1:1 HD	2
14	95121H	17+ RAPTOR BUMP HARDWARE KIT	1

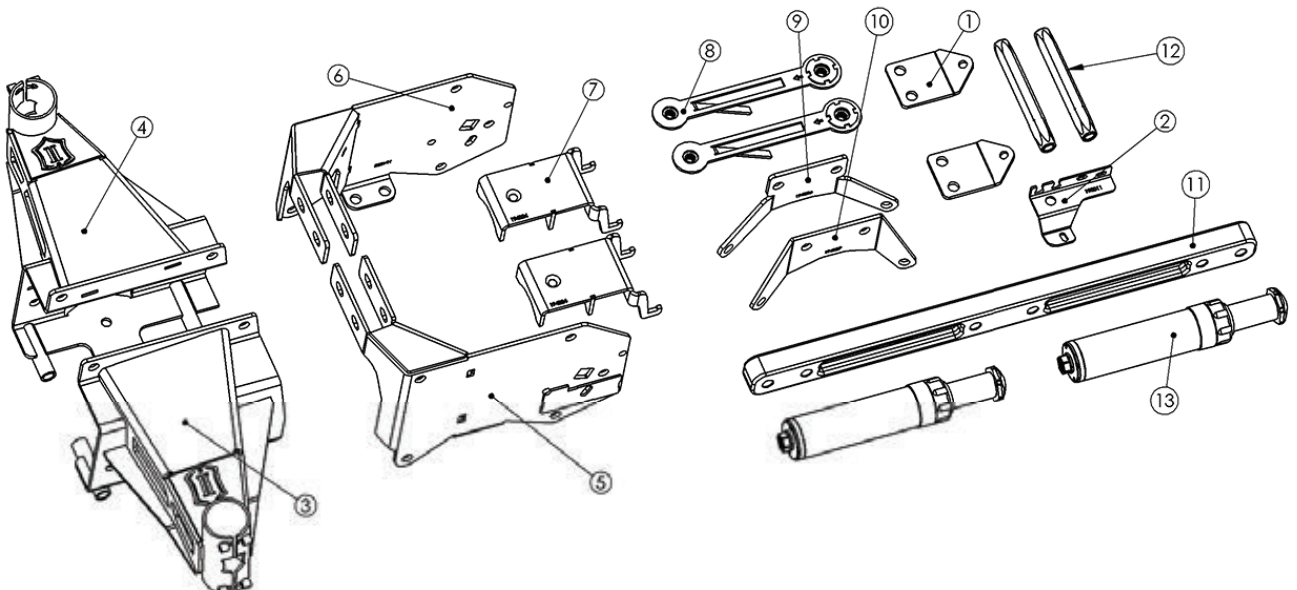

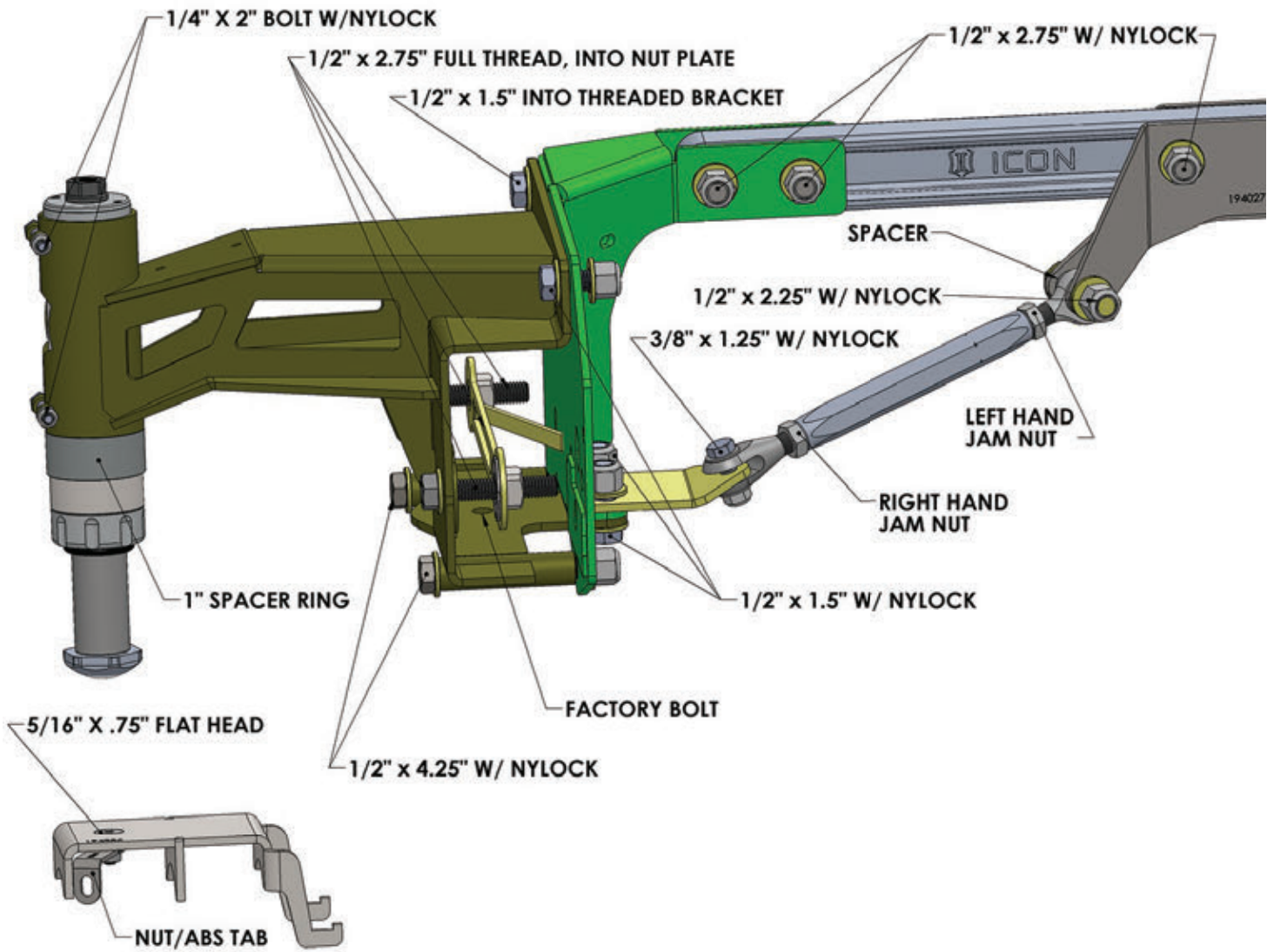



## 2.0 SERIES BUMP STOP TECHNICAL INFORMATION

### MAINTENANCE

ICON shock absorbers are a high quality rebuildable race style shock absorber designed for optimal performance. With a unit of this caliber on your vehicle, routine maintenance is required to keep them looking and operating in like new condition. Residual oil and assembly lube may be present at all seal paths from the factory out of the box and is considered normal. Pooling of oil however is not acceptable at any time and one should contact the ICON dealer where purchased.

**BELOW ARE GUIDELINES BASED ON HOW YOU USE YOUR VEHICLE BUT YOUR MILEAGE MAY VARY:**

#### **STREET USE:**

- Send in for factory servicing every 40,000 miles or if a leak develops, ride quality decreases, or they begin to make excessive noise.
- Remove any buildup of road salt, mud, or debris from shocks anytime accrued
- Clean with mild soap and water with each oil change or anytime you notice build up.
- Wax the cylinders yearly with automotive wax to prevent corrosion.
- Check nitrogen pressure yearly. (252004 charge needle assembly available at any ICON distributor)

#### **STREET/DIRT:**

- Send in for factory servicing every 15,000 miles or if a leak develops, ride quality decreases, or they begin to make excessive noise.
- Clean with mild soap and water with each oil change, offroad trip, or anytime you notice build up.
- Wax the cylinders yearly with automotive wax to prevent corrosion.
- Check nitrogen pressure each dirt outing. (252004 charge needle assembly available at any ICON distributor)

#### **DIRT USE:**

- Send in for factory servicing every 1,000 miles.
- Check nitrogen pressure each outing. (252004 charge needle assembly available at any ICON distributor)
- Remove any buildup of mud or debris from shocks after every outing.