



**i** **BEAM**<sup>TM</sup>

VEHICLE SAFETY SYSTEMS

# **TE-SBC**

## **Product Manual**



# I. Specifications

---

SENSOR	CMOS II
Effective Pixel	656 X 492
Horizontal Sync Frequency	15625KHZ
Vertical Sync Frequency	PAL50HZ / NTSC 60HZ
Scanning System	2 : 1 Interlace
Sync System	Internal
AGC	Auto
BLC	Auto
Resolution	420 TV Lines
S/N Ratio	More Than 48dB
Current Consumption	No More 150mA
Power Supply	DC12V $\pm$ 10%
Operating Temperature	-22° ~ 176° F
Storage Temperature	-40° ~ 176° F
Viewing Angle	170°
Water-Proof	IP67
Minimum Illumination	0.5Lux/F1.2(0Lux with LED)

## II. Connection

---

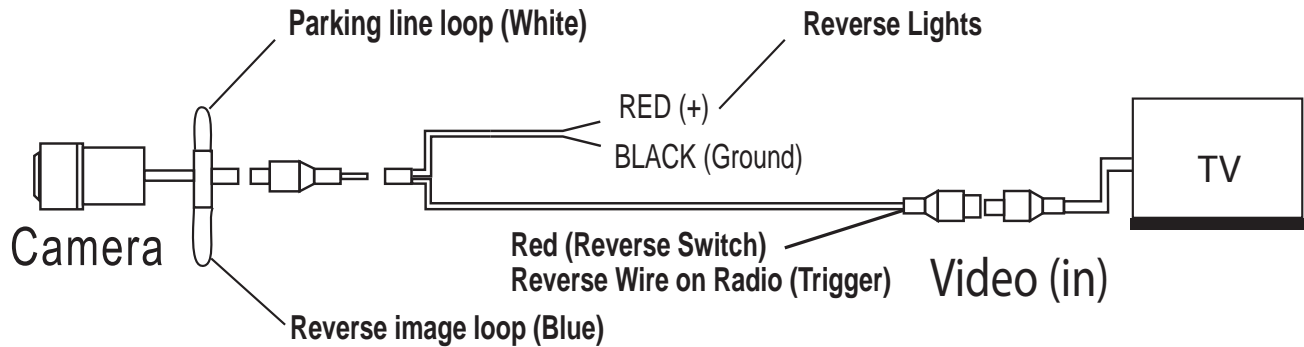

- 1) Find a suitable location to mount the camera, there are two ways to mount this camera either a Surface mount or with the supplied Flush mount hardware.
- 2) “Surface mount” install, make sure the camera’s view is unobstructed and be careful not to drill into any wires that might damage the vehicle. When all connections have been made and before mounting the camera, verify the camera is working and has good view of the area. Then mount the camera down with the supplied two screws.
- 3) “Flush mount” install, make sure the camera’s view is unobstructed and be careful not to drill into any wires that might damage the vehicle, also check to make sure you have enough depth for install. When all connections have been made and before mounting the camera, make sure the camera comes on and you have a good view of the area. Use the supplied 16.5mm hole saw bit to drill a hole for flush mounting of camera and use flush mount hardware. Once the camera is verified working, remove the front lens by unscrewing it counter-clockwise and remove the surface mount bracket then reattach the front lens and use the flush mount hardware to install.
- 4) Connect the RED wire to the +12 volt reverse wire of the vehicle.
- 5) Connect the BLACK wire to ground (a metal, non-painted surface).
- 6) Run video cable through vehicle, up to video display. (Avoid placing video cable where it can get pinched or damaged).
- 7) Attach the YELLOW video rca to the reverse camera input of the radio or video display; connect the RED wire coming from the YELLOW video rca to the reverse trigger wire on the radio or video display.

**NOTE:** The camera comes with the parking assist lines and a normal image view active. If you want to remove the parking lines or change the image to reverse image, follow the steps below:

- A) Disconnect power to the camera
- B) Cut the WHITE loop to remove the parking assist lines, isolate and tape the wires
- C) Cut the BLUE loop to reverse the image, isolate and tape the wires
- D) Reconnect power to the camera

If the parking assist lines are wanted or the image needs to go back to normal, just follow the steps above and reconnect the wires.