

**FORD F150
WITH FENDER FLARES****REAR MUD GUARD INSTALLATION INSTRUCTIONS**

*Install Paint Protection Film before mud guards (see other side)
Please read instructions thoroughly before installation.*

Tools Required

- 1/8" drill bit / Drill
- Short #2 Phillips screwdriver
- Center punch
- Pliers

Package Contents

- Driver & passenger side rear mud guard
- #10 SEM screw (qty. 4)
- M6 bolt (qty 2)
- U-clip (qty. 2)
- Spring clip (qty. 4)
- Paint Protection Film (1 set)
- Instruction sheet

NOTE: Turn the front wheels all the way to the left or right for mud guard installation. However, it may be necessary to remove the wheels depending on the tools being used for installation.

Determine which mudguard you have by locating the part number molded in the mounting flange (5945 LH 5945 RH).

1. Clean and degrease the mud guard location area on the fender before installation.
2. Remove existing fasteners from location A and C and discard.
3. Install u-clip at location A over the existing hole
4. Peel red protective cover from the 3M adhesive on the mudguard.
5. Attach mud guard to fender with the M6 bolt at location C, and #10 SEM screw at location A through the mudguard and fender into the u-clips at location A and C. Check fit and make sure mud guard is parallel to ground before tightening. Be sure to press firmly on the area with the 3M adhesive tape to make sure adhesive is set.
6. Clip the spring clips over the mudguard and fender flare. The mudguard is marked with tick marks for location.

OPTIONAL FASTENER INSTALLATION

7. Using the mud guard as a template mark, center punch and drill 1/8" hole at location B.
8. Install #10 SEM screw through the mudguard and into the fender flare at location B.

NOTE: Due to the tight fit of the spring clip it may be necessary to increase the spring clip panel opening by prying the open end of the spring clip apart with a flat head screw driver.

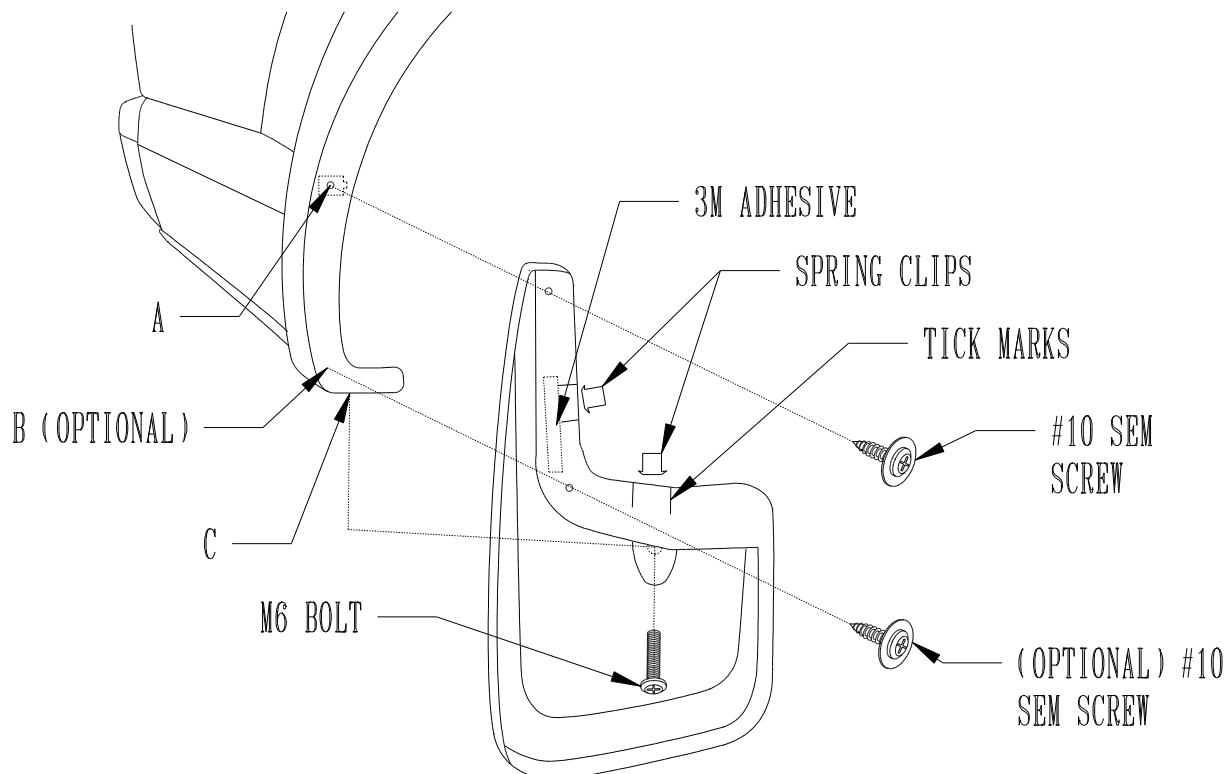

PAINTING INSTRUCTIONS

Note: *If painting mud guards, perform a mud guard test fit to ensure correct fit and application prior to painting.*

1. Clean mud guard with a soap and water solution to remove dirt and other contaminants.
2. Sand painting surface with 320 grit sand paper.
3. Apply a coating of flexible primer-adhesion promoter.
4. Apply a flexible paint as directed by the paint manufacturer.

PAINT PROTECTION FILM - INSTALLATION INSTRUCTIONS

NOTE: *The Paint Protection Film is a precut template of film used to protect the mud guard mounting surfaces of your fenders against wear. The templates (left and right side) can be removed from the backing liner by folding the liner at the center cut of the template, separating the film sides and peeling the film templates from the backing liner.*

1. Position mud guard on fender to indicate placement location of paint protection film.
2. Clean the placement area of fender with a clean cotton cloth and a petroleum distillate based cleaner such as DuPonts Prep-Sol Brand Solvent Cleaner or 3M Brand Adhesive Cleaner and dry.
3. Mix a wetting solution of 1 pint of water with 4 drops of liquid dishwashing detergent.
4. Mark correct position of film by placing mud guard against fender. **Make sure film extends beyond edge of mud guard contour a minimum of an 1/8"**.
5. Remove protection film from liner and flood adhesive side of film with wetting solution (use a spray bottle or sponge).
6. Thoroughly wet film placement location of fender with wetting solution.
7. Position the adhesive side of film on fender and flood with wetting solution.
8. Check location of film with mud guard and reposition as necessary.
9. Using a sponge, squeegee any air bubbles and wrinkles from film.
10. Allow film to dry before installing mud guard.

