

Please read instructions thoroughly before installation.

Tools Required

- Short Phillips screwdriver
- Center punch
- Drill / 1/8" drill bit

Package Contents

- Driver & passenger side front mud guards
- #10 Phillips Head SEM Screw (qty. 6)
- Medium U-Clip (qty. 6)
- Spring Clip (qty 2)
- Paint Protection Film (1 set)
- Instruction sheet

IMPORTANT! PLEASE READ BEFORE ANY INSTALLATION. DURING THE 2011 MODEL YEAR, DODGE MANUFACTURED RAM TRUCKS WITH 2 DIFFERENT LOWER FENDER "ROCK GUARDS". PLEASE REVIEW THE IMAGES BELOW AND IDENTIFY YOUR SPECIFIC "ROCK GUARD" CONFIGURATION AND FOLLOW THE CORRESPONDING INSTALLATION INSTRUCTIONS. ALL 2012 AND NEWER VEHICLES HAVE THE LARGE ROCK GUARD WHICH WILL HAVE TO BE REMOVED FOR MUD GUARD INSTALLATION.

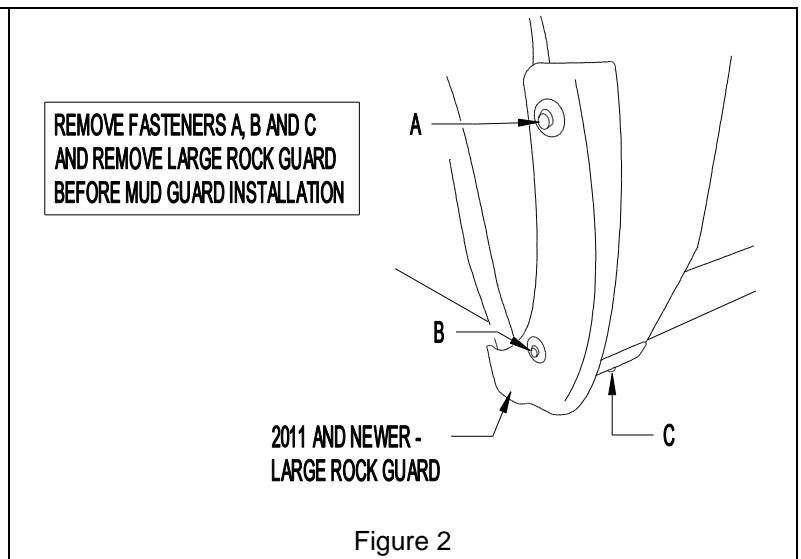
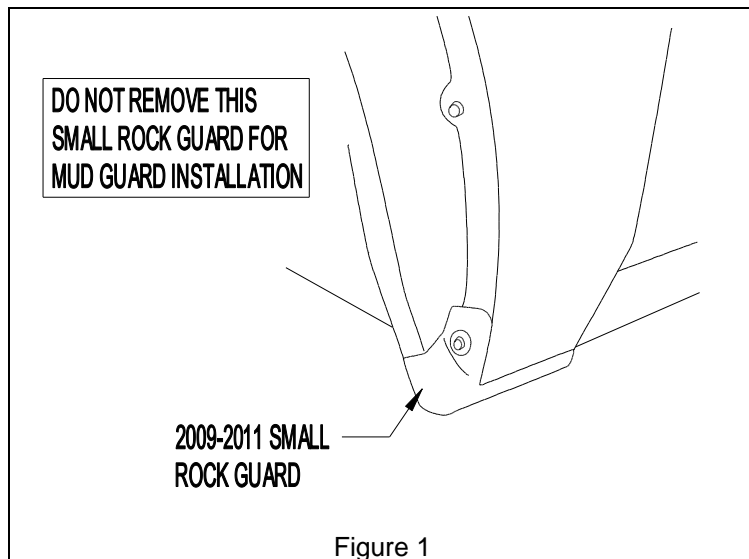

VEHICLE PREPARATION

FIGURE 1: If you have the "small rock guard" as shown in Figure 1., simply leave the rock guard in place. Next, follow the paint protection film instructions and then the mud guard installation instructions.

FIGURE 2: If you have a 2011 or newer Dodge Ram with the "large rock guard" as shown in Figure 2, remove fasteners A, B, and C, and remove the "large rock guard" (Figure 3). After removal of the "large rock guard" reinstall fastener C. Then proceed with the paint protection film instructions followed by the mud guard installation instructions.

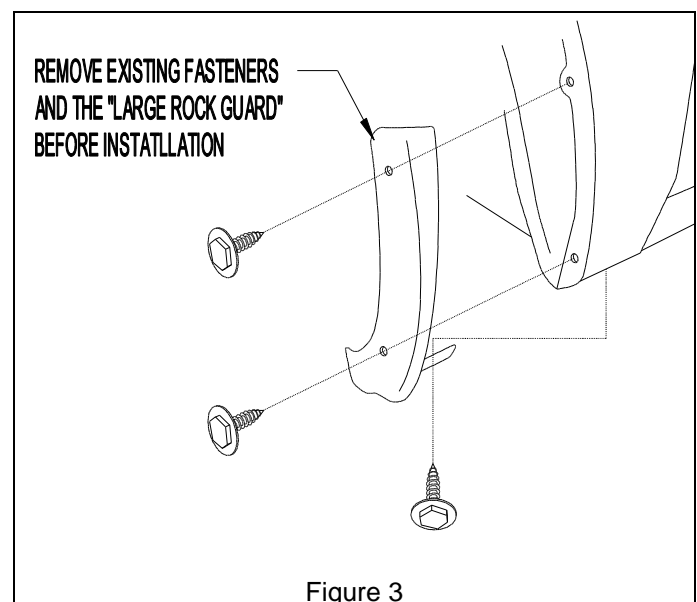

PAINT PROTECTION FILM INSTALLATION

The Paint Protection Film is a precut template of film used to protect the mud guard mounting surfaces of your fenders against wear. The templates (left and right side) can be removed from the backing liner by folding the liner at the center cut of the template, separating the film sides and peeling the film templates from the backing liner.

NOTE: Install the paint protection film supplied in your installation kit before installing the mud guards.

1. If you have the "large rock" shown in Figure 2, remove the large rock guard before you install the paint protection film. If you have the small rock guard shown in Figure 1, leave the small rock guard in place and proceed with the paint protection film installation as shown.
2. Position mud guard on fender to indicate placement location of paint protection film.
3. Clean the placement area of fender with a clean cotton cloth and a petroleum distillate based cleaner such as DuPont Prep-Sol Brand Solvent Cleaner or 3M Brand Adhesive Cleaner and dry.
4. Mix a wetting solution of 1 pint of water with 4 drops of liquid dishwashing detergent.
5. Mark correct position of film by placing mud guard against fender.
6. Remove protection film from liner and flood adhesive side of film with wetting solution (use a spray bottle or sponge).
7. Thoroughly wet film placement location of fender with wetting solution.
8. Position the adhesive side of film on fender and flood with wetting solution.
9. Check location of film with mud guard and reposition as necessary.
10. Using a sponge, squeegee any air bubbles and wrinkles from film.
11. Allow film to dry before installing mud guard.

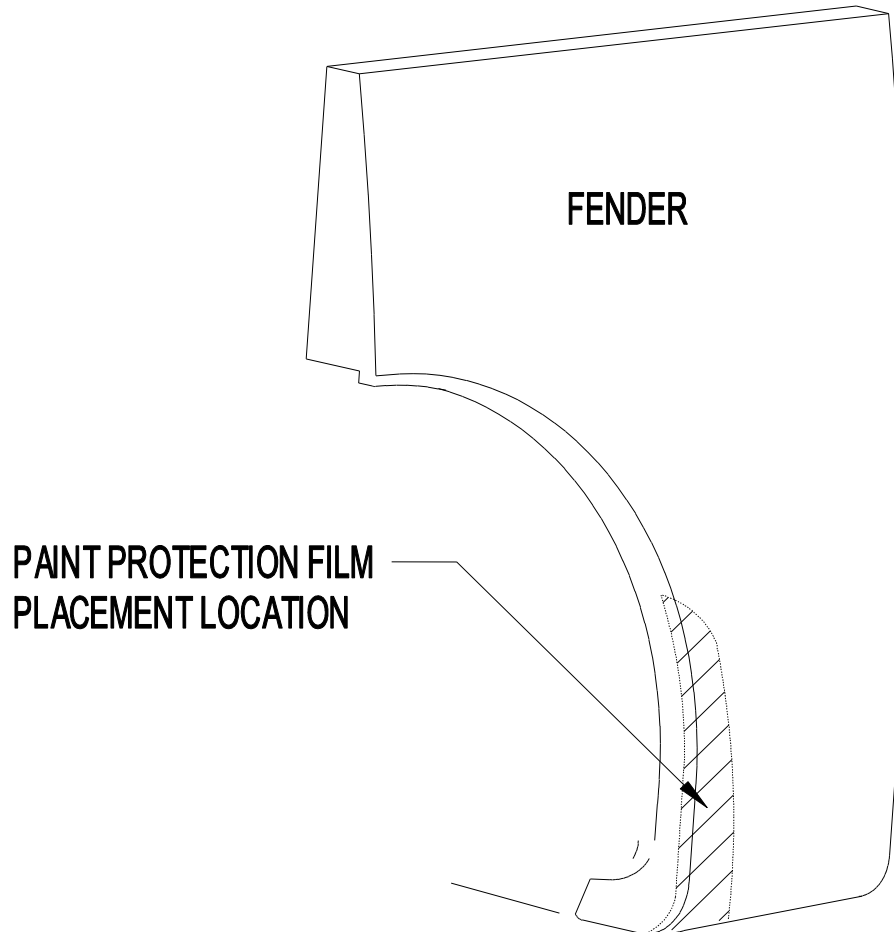

MUD GUARD INSTALLATION

2009-2011 WITH
SMALL ROCK
GUARD

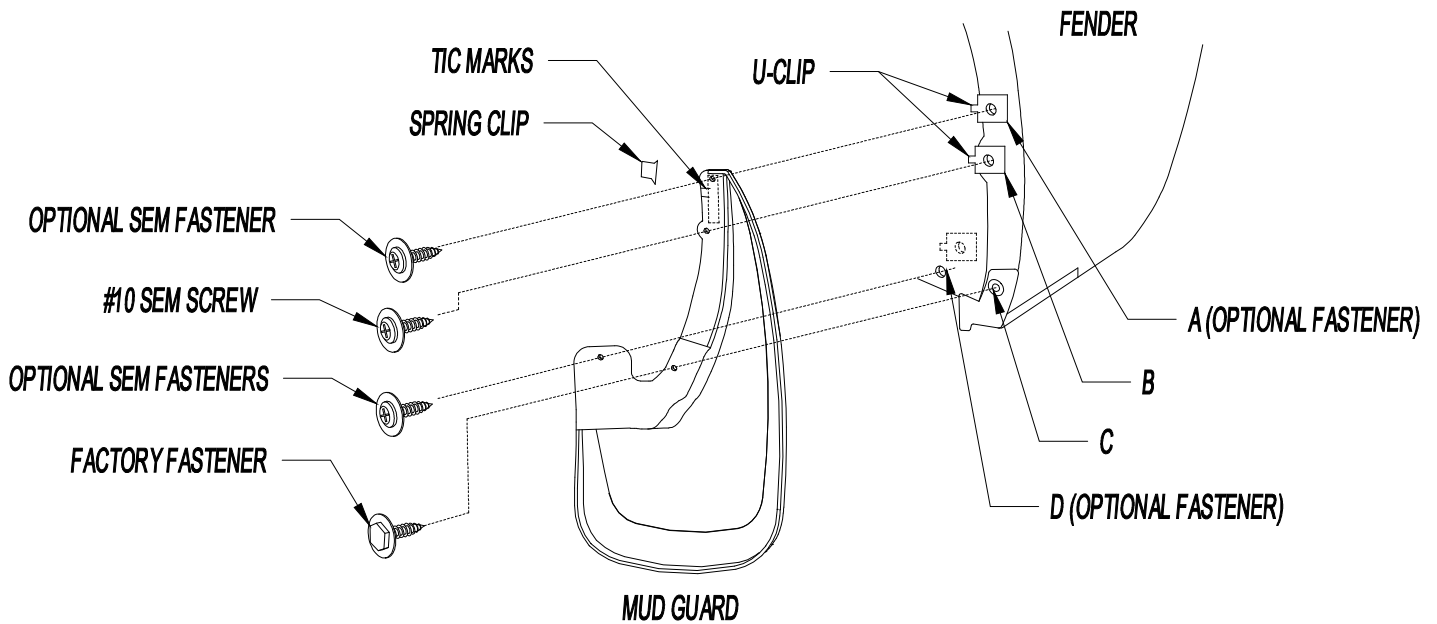

2011 AND NEWER
WITH LARGE ROCK
GUARD

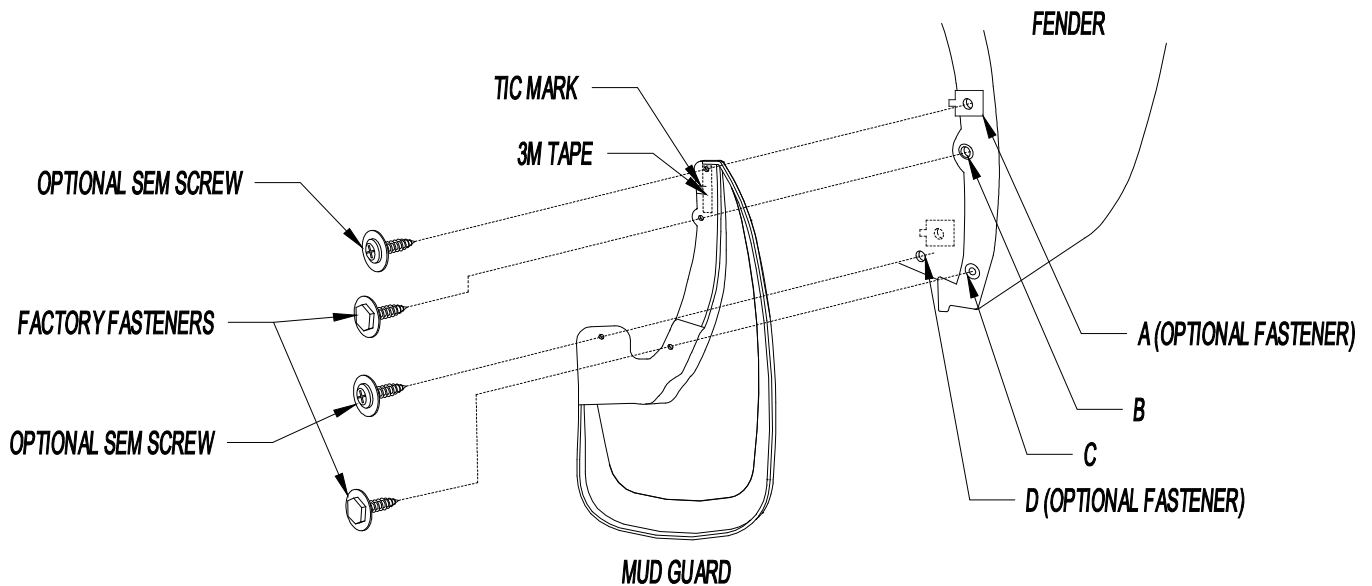

NOTE: Turn wheels all the way left or right for easier installation. It may be necessary to remove the wheels before mud guard installation.

Determine which mudguard you have by locating the part number molded in the mounting flange (5817 LH 5817 RH).

1. Remove the existing fastener from location C with small "rock guard" or from locations A, B and C if you have the "large rock guard" and discard the large rock guard. Replace fastener C after removal of the "large rock guard" if applicable.
2. If there is not an existing factory fastener at location B, install a Medium U-Clip over the factory hole at location B
3. Peel the red protective cover from the 3M tape on the mud guard
4. Attach the mud guard at location C (and B if applicable) with the existing fastener(s). Check the mud guard fit and appearance before tightening.
5. Press firmly on the area with the tape to set the tape in place and install the supplied spring clip and the tic mark location.
6. **Optional Fasteners.** Using the mud guard as a template, mark and drill 1/8" hole at location D and install a #10 SEM screw through the mudguard and fender liner and into the u-clip on the back side of the fender liner(**U-clip does not clip over the fender liner**)
7. Using the mud guard as a template, mark and drill 1/8" hole at location A. Install a Medium U-Clip at location A and install a #10 SEM Screw at location A. (Note **U-Clip clips over the sheet metal**).