

**CHEVROLET TRAILBLAZER**  
**REAR MUD GUARD INSTALLATION INSTRUCTIONS**

*Please read instructions thoroughly before installation.*

**Tools Required**

- 1/8" drill bit / Drill
- Short Phillips screwdriver
- Marking utensil (fine tip marker, grease pencil, etc.)
- Center punch / Hammer

**Package Contents**

- Driver & passenger side rear mud guard
- #10 SEM screw (qty. 10)
- U-Clips (qty. 4)
- Instruction sheet

**NOTE:** It may be necessary to remove the rear wheels depending on the tools being used for installation.

1. Clean and degrease the mud guard location area on the fender before installation.
2. Using mud guard as a template, mark, center punch, and drill 1/8" hole at location A, B, and C (Figure 1).
3. Attach mud guard to fender with #10 SEM screws at location A, B, and C, check fit and level before tightening.
4. Mark and drill 1/8" holes on the fender liner at locations D and E.
5. Install #10 SEM screws at locations D and E, through mud guard, fender liner and into a U-clip on the back side of the liner.

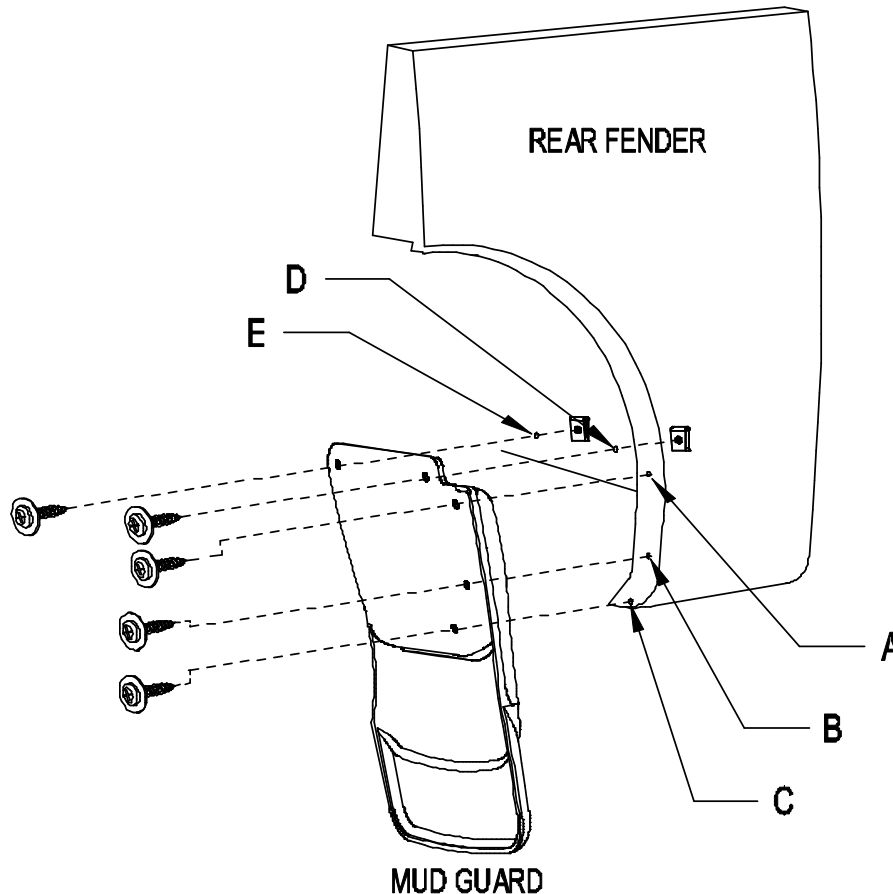

Figure 1

**PAINTING INSTRUCTIONS**

1. Clean mud guard with a soap and water solution to remove dirt and other contaminants.
2. Sand painting surface with 320 grit sand paper.
3. Apply a coating of flexible primer-adhesion promoter.
4. Apply a flexible paint as directed by the paint manufacturer.