

DODGE RAM WITHOUT FENDER FLARES

REAR MUD GUARDS INSTALLATION INSTRUCTIONS

Please read instructions thoroughly before installation.

Tools Required

- Short Phillips screwdriver
- Center punch
- Drill / 1/8" drill bit

Package Contents

- Driver & passenger side front mud guards
- #10 (1-1/2") Screw (qty. 2)
- Fender Washer (qty. 2)
- Small U-Clip (qty. 2)
- Paint Protection Film (1 set)
- Instruction sheet

IMPORTANT! PLEASE READ BEFORE ANY INSTALLATION. STARTING IN 2011, DODGE MANUFACTURED RAM TRUCKS WITH 2 DIFFERENT LOWER FENDER "ROCK GUARDS". PLEASE REVIEW THE IMAGES BELOW AND IDENTIFY YOUR SPECIFIC "ROCK GUARD" CONFIGURATION AND FOLLOW THE CORRESPONDING INSTALLATION INSTRUCTIONS.

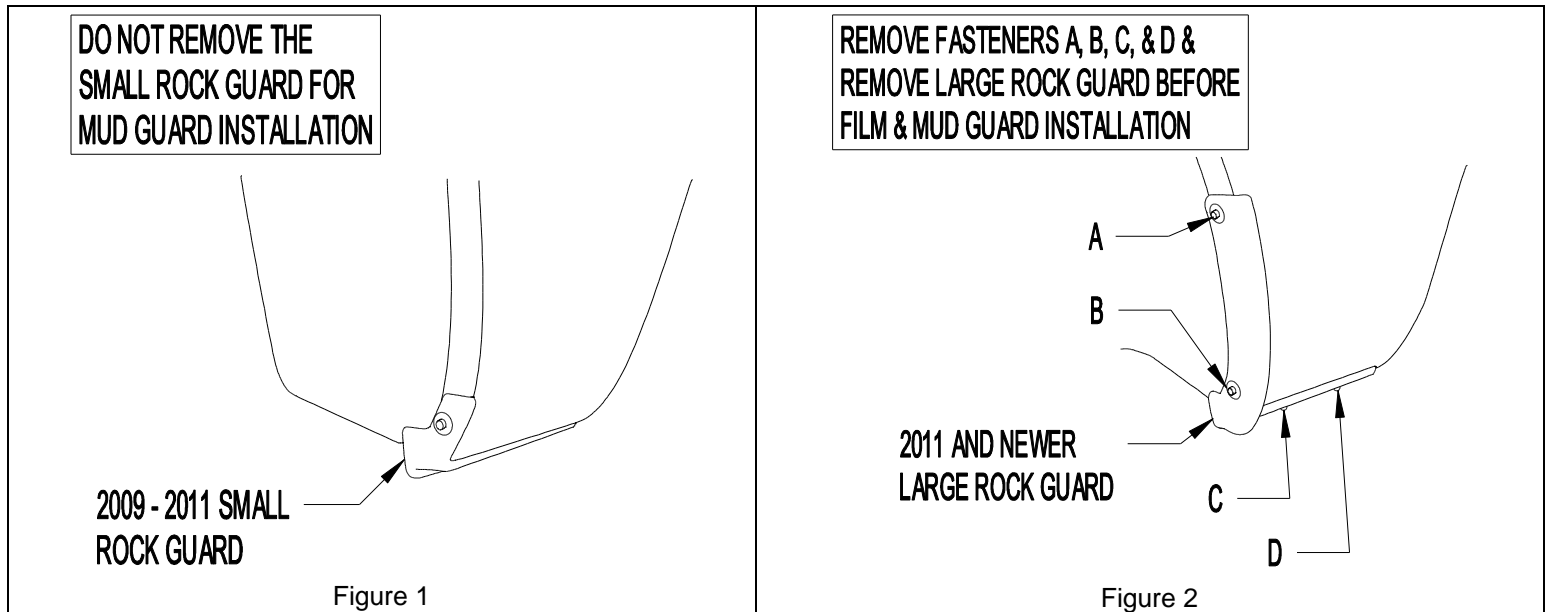

VEHICLE PREPARATION

FIGURE 1: If you have the “small rock guard” as shown in Figure 1., simply leave the rock guard in place. Next, follow the paint protection film instructions and then the mud guard installation instructions.

FIGURE 2: If you have a 2011 or newer Dodge Ram with the “large rock guard” as shown in Figure 2, remove fasteners A, B, C, and D, and remove the “large rock guard” (Figure 3). After removal of the “large rock guard” reinstall fastener C. Then proceed with the paint protection film instructions followed by the mud guard installation instructions.

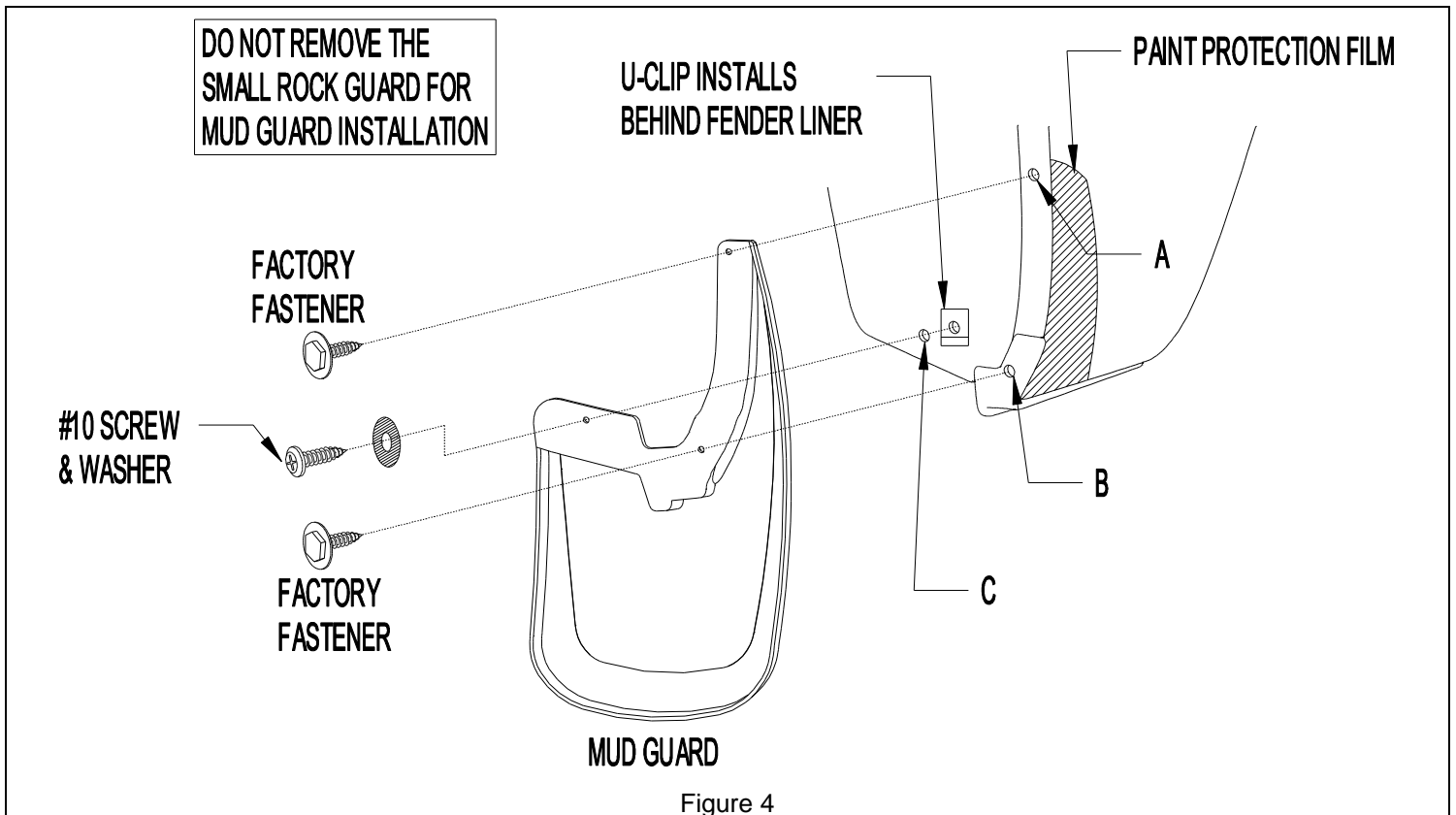
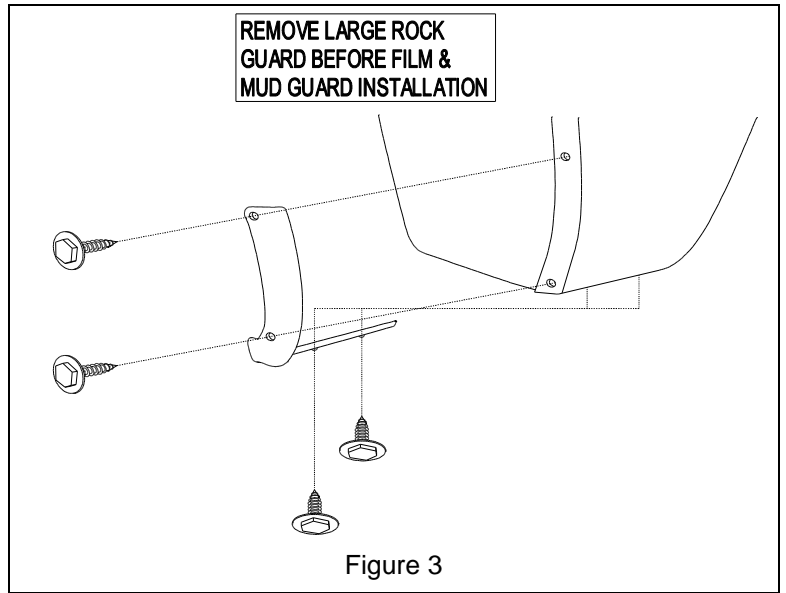

SMALL ROCK GUARD FILM AND MUD GUARD INSTALLATION

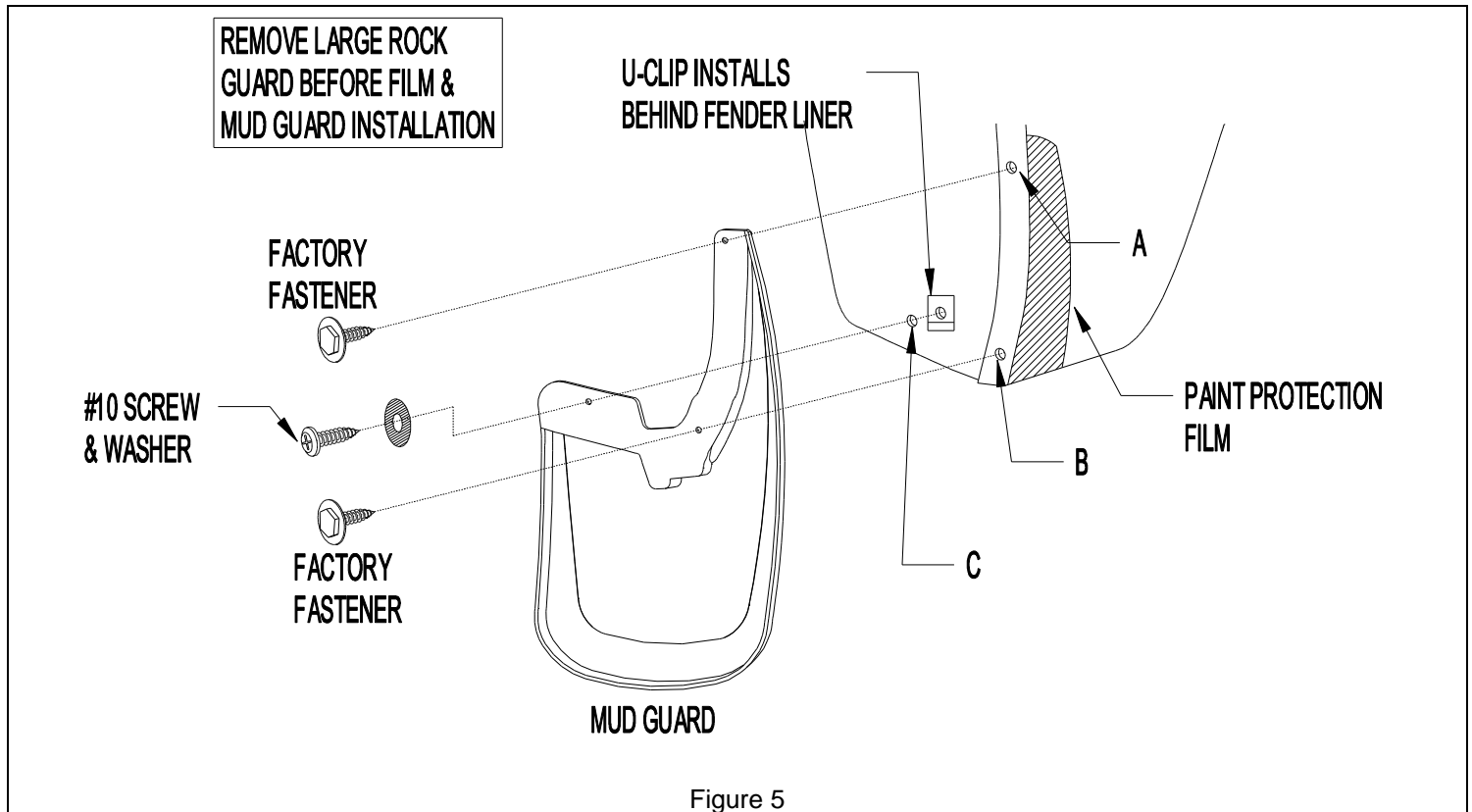

Figure 5

LARGE ROCK GUARD FILM AND INSTALLATION INSTRUCTION

PAINT PROTECTION FILM INSTALLATION

The Paint Protection Film is a precut template of film used to protect the mud guard mounting surfaces of your fenders against wear. The templates (left and right side) can be removed from the backing liner by folding the liner at the center cut of the template, separating the film sides and peeling the film templates from the backing liner.

NOTE: Install the paint protection film supplied in your installation kit before installing the mud guards.

1. If you have the "large rock" shown in Figure 2, remove the large rock guard before you install the paint protection film as shown in Figure 5. If you have the small rock guard shown in Figure 1, leave the small rock guard in place and proceed with the paint protection film installation as shown in Figure 4.
2. Position mud guard on fender to indicate placement location of paint protection film.
3. Clean the placement area of fender with a clean cotton cloth and a petroleum distillate based cleaner such as DuPont Prep-Sol Brand Solvent Cleaner or 3M Brand Adhesive Cleaner and dry.
4. Mix a wetting solution of 1 pint of water with 4 drops of liquid dishwashing detergent.
5. Mark correct position of film by placing mud guard against fender.
6. Remove protection film from liner and flood adhesive side of film with wetting solution (use a spray bottle or sponge).
7. Thoroughly wet film placement location of fender with wetting solution.
8. Position the adhesive side of film on fender and flood with wetting solution.
9. Check location of film with mud guard and reposition as necessary.
10. Using a sponge, squeegee any air bubbles and wrinkles from film.
11. Allow film to dry before installing mud guard.



PART NO: 5715

MUD GUARD INSTALLATION

NOTE: Turn wheels all the way left or right for easier installation. It may be necessary to remove the wheels before mud guard installation.

Determine which mudguard you have by locating the part number molded in the mounting flange (5715 LH 5715 RH).

1. Remove the existing fastener from locations A and B as well as locations C and D if you have the 'Large Rock Guard'. Replace C and D after removal of the "large rock guard" if applicable. Once again, use Figure 4 if you have the "rock guard" in Figure 1 or use Figure 5 if you have the "large rock guard" in Figure 2.
2. Attach the mud guard at locations A and B with the existing fasteners. Check the mud guard fit and appearance before tightening.
3. Using the mud guard as a template, mark and drill 1/8" hole at location C (Figure 4 or 5).
4. Install a #10 Screw and Washer at location C, thru the mud guard, fender liner and into a Small U-Clip on the backside of the fender liner.