

DODGE DAKOTA WITH FENDER FLARES REAR MUD GUARD INSTALLATION INSTRUCTIONS

Please read instructions thoroughly before installation.

Tools Required

- 1/8" drill bit / Drill
- T20 TORX Wrench
- Short #2 Phillips screwdriver
- Marking utensil

Package Contents

- Driver & passenger side rear mud guard
- #10 screw (qty. 6)
- U-Clip (qty. 2)
- Instruction sheet

NOTE: It may be necessary to remove the rear wheels for mud guard installation.

1. Clean and degrease the mud guard location area on the fender before installation.
2. Remove factory fastener from location C (Figure 1).
3. Attach mud guard to rear fender with factory fastener at location C. Make sure that the mud guard is level to the ground before continuing.
4. Using the mud guard as a template, mark and drill an 1/8" hole at location A, B and D (Figure 1).
5. Install a #10 screw at locations A and B.
6. Install a #10 screw at locations D, through the mud guard and liner and into a U-Clip (Figure 2).

NOTE: The U-Clip is used as a nut for the #10 screw and does not clip over the fender or fender liner.

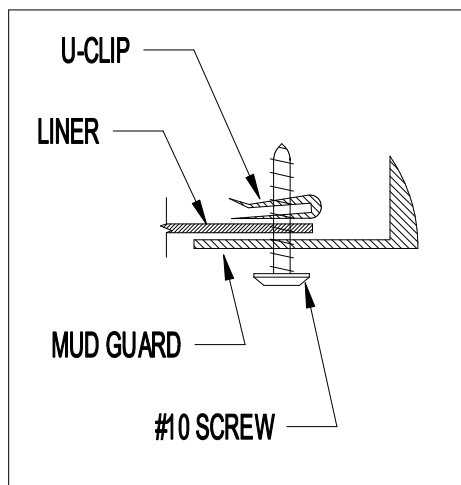

Figure 2

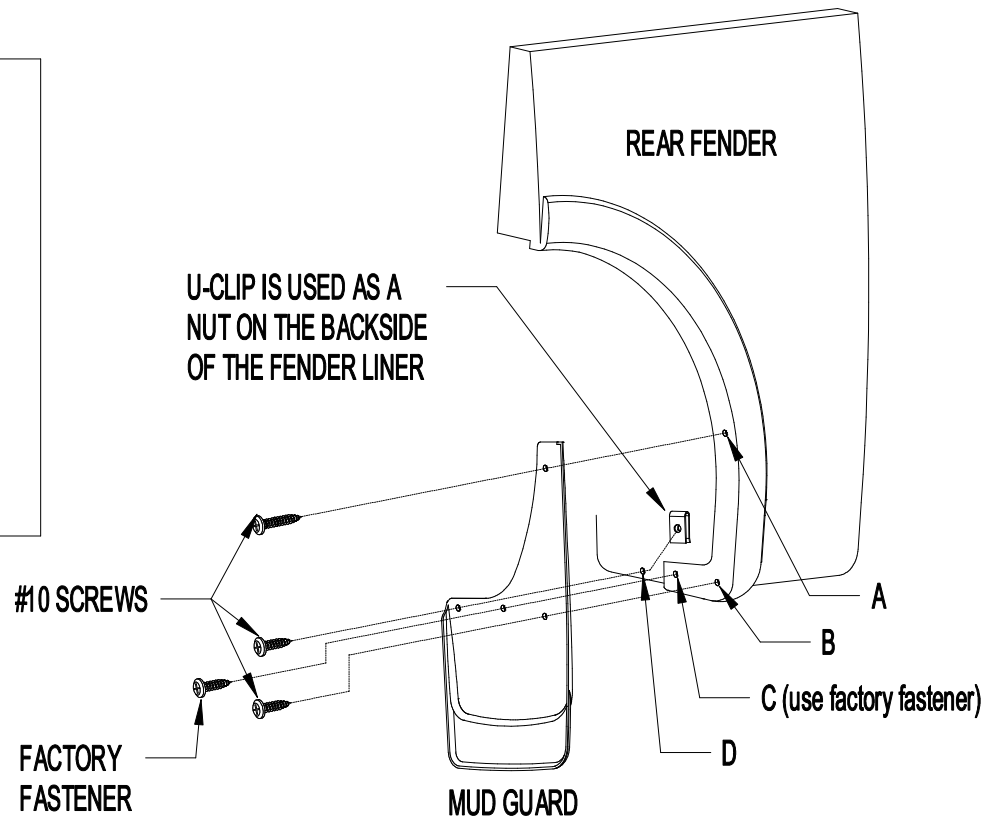

Figure 1

PAINTING INSTRUCTIONS

1. Clean mud guard with a soap and water solution to remove dirt and other contaminants.
2. Sand painting surface with 320 grit sand paper.
3. Apply a coating of flexible primer-adhesion promoter.
4. Apply a flexible paint as directed by the paint manufacturer.