

DODGE DAKOTA
FRONT MUD GUARD INSTALLATION INSTRUCTIONS

Install paint protection film before mud guard (see other side). Please read instructions thoroughly before installation.

Tools Required:

- 1/8" drill bit / Drill
- Center punch / Hammer
- Short Phillips screwdriver or drill attachment
- Marking utensil (fine tip marker, grease pencil, etc.)

Package Contents

- Driver & passenger side mud guard
- #10 SEM screw (qty. 8)
- U-clip (qty. 4)
- Paint Protection Film (1set)
- Instruction sheet

NOTE: Turn the front wheels all the way to the left or right for mud guard installation. However, it may be necessary to remove the wheels depending on the tools being used for installation.

1. Clean and degrease the mud guard location area on the fender before installation.
2. Remove existing fastener from location C (Figure 1).
3. Attach mud guard to front fender at location C by installing a #10 SEM screw thru mud guard, fender and into a U-clip. **NOTE:** the U-clip is placed on the backside of liner and acts as a nut. **DO NOT** clip over liner or fender. Check fit and parallel. Adjust accordingly before tightening (Figure 1 and 2).
4. Using mud guard as a template, mark, drill 1/8 holes and install #10 SEM screws at locations A and B.
5. Using mud guard as a template, mark, drill 1/8 hole and install #10 SEM screw at location D, thru mud guard, fender liner and into a u-clip on the backside of liner. The u-clip is used as a nut, **DO NOT** clip over liner or sheet metal (Figures 1 and 2).

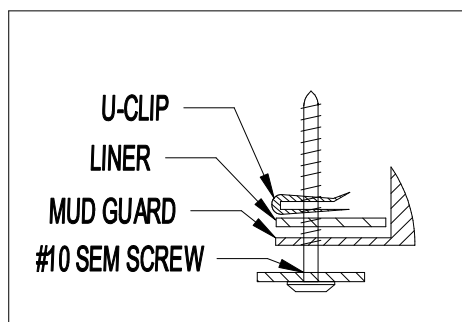

Figure 2

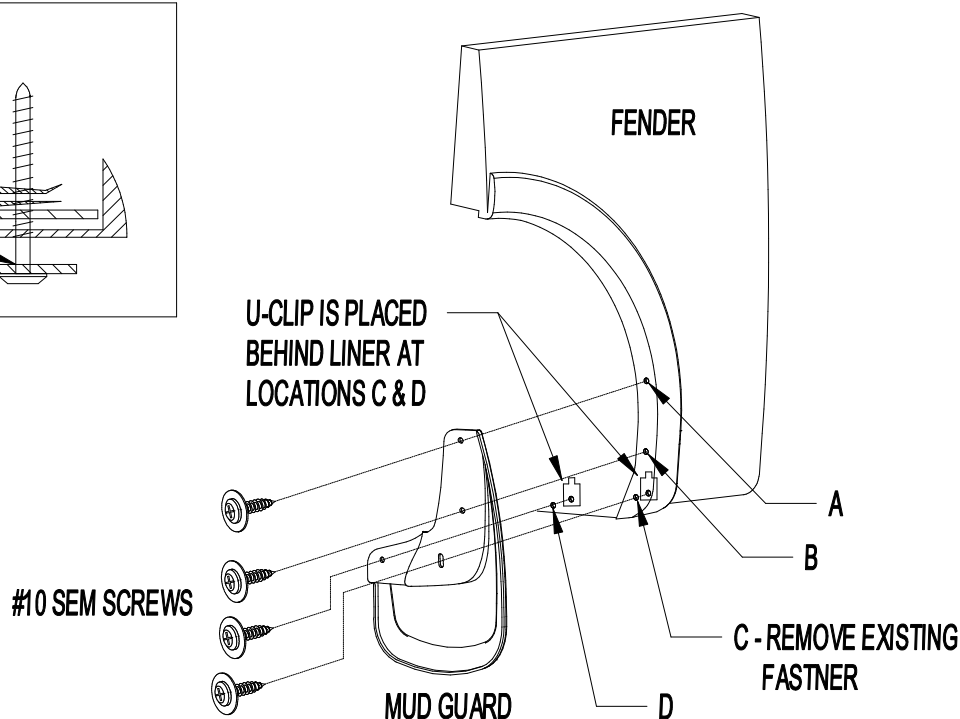

Figure 1

PAINTING INSTRUCTIONS

Note: *If painting mud guards, perform a mud guard test fit to ensure correct fit and application prior to painting.*

1. Clean mud guard with a soap and water solution to remove dirt and other contaminants.
2. Sand painting surface with 320 grit sand paper.
3. Apply a coating of flexible primer-adhesion promoter.

4. Apply a flexible paint as directed by the paint manufacturer

PAINT PROTECTION FILM - INSTALLATION INSTRUCTIONS

NOTE: *The Paint Protection Film is a precut template of film used to protect the mud guard mounting surfaces of your fenders against wear. The templates (left and right side) can be removed from the backing liner by folding the liner at the center cut of the template, separating the film sides and peeling the film templates from the backing liner.*

1. Position mud guard on fender to indicate placement location of paint protection film.
2. Clean the placement area of fender with a clean cotton cloth and a petroleum distillate based cleaner such as DuPonts Prep-Sol Brand Solvent Cleaner or 3M Brand Adhesive Cleaner and dry.
3. Mix a wetting solution of 1 pint of water with 4 drops of liquid dishwashing detergent.
4. Mark correct position of film by placing mud guard against fender. **Make sure film extends beyond edge of mud guard contour a minimum of an 1/8”.**
5. Remove protection film from liner and flood adhesive side of film with wetting solution (use a spray bottle or sponge).
6. Thoroughly wet film placement location of fender with wetting solution.
7. Position the adhesive side of film on fender and flood with wetting solution.
8. Check location of film with mud guard and reposition as necessary.
9. Using a sponge, squeegee any air bubbles and wrinkles from film.
10. Allow film to dry before installing mud guard.