

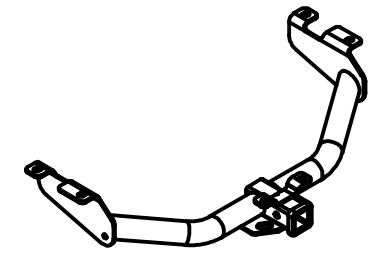

# Class III Receiver Hitch

## Part No. 69562C



**Fits:** '99 - '07 (CLASSIC), '07 - CURRENT (NEW BODY) STYLE  
CHEVY/GMC 1500/2500LD SILVERADO, SIERRA, Z71



GROSS LOAD CAPACITY WHEN USED AS A WEIGHT CARRYING HITCH: 6,000 LBS. TRAILER WEIGHT & 600 LBS. TONGUE WEIGHT.  
GROSS LOAD CAPACITY WHEN USED AS A WEIGHT DISTRIBUTION HITCH: 10,000 LBS. TRAILER WEIGHT & 1,000 LBS. TONGUE WEIGHT  
WARNING: \*\*\* DO NOT EXCEED VEHICLE MANUFACTURER'S RECOMMENDED TOWING CAPACITY. \*\*\*



Parts List			
ITEM	QTY	PART NUMBER	DESCRIPTION
1	2	1/2-13 x 1 3/4	CARRIAGE BOLT
2	2	CM-SP1	.250 x 1.50 x 2.00" SQUARE HOLE SPACER
3	2	HFN 1213	HEX FLANGE NUT
4	4	M14-2 x 40mm LG.	HEX BOLT
5	4	9/16"	CONICAL TOOTHED WASHER

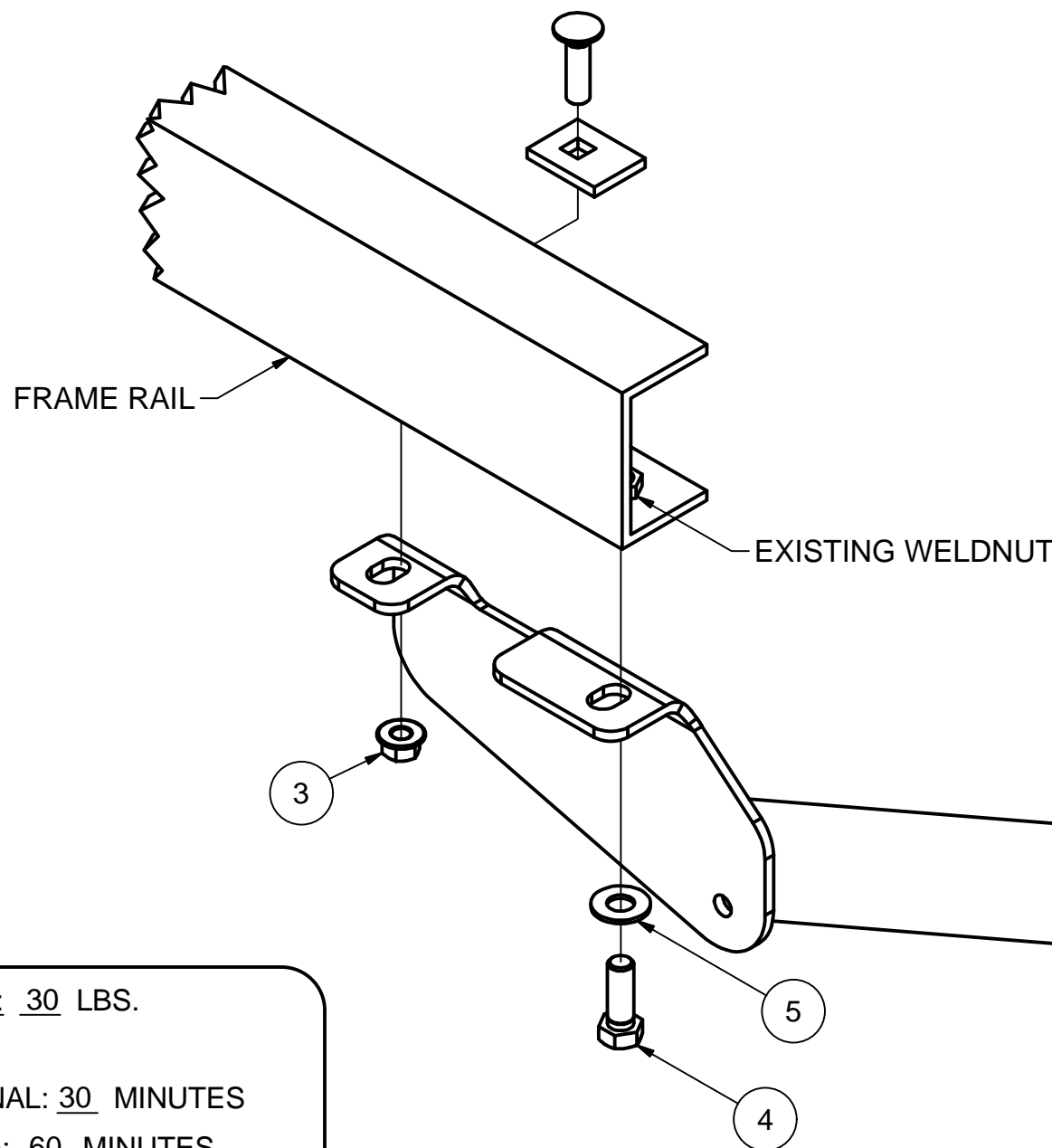
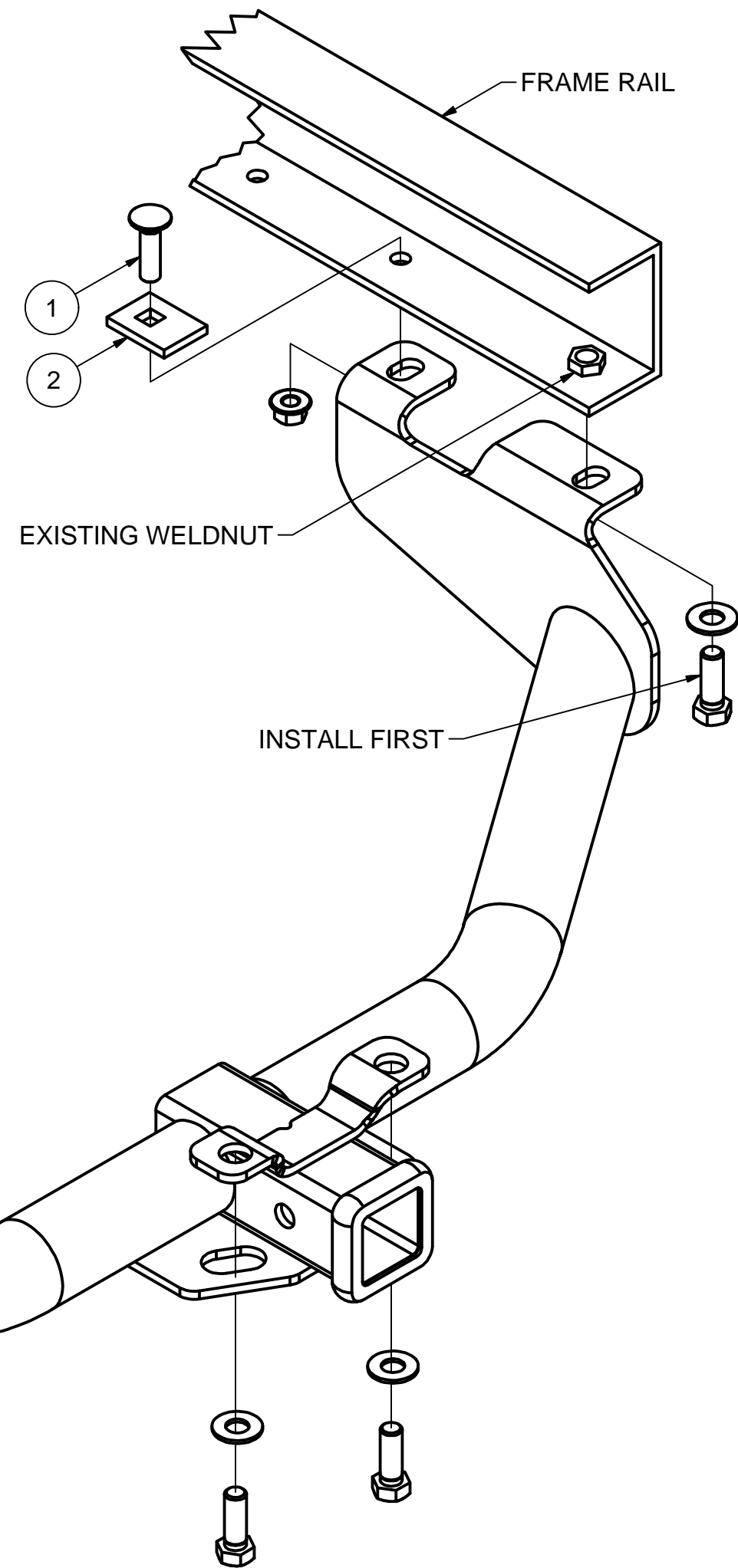
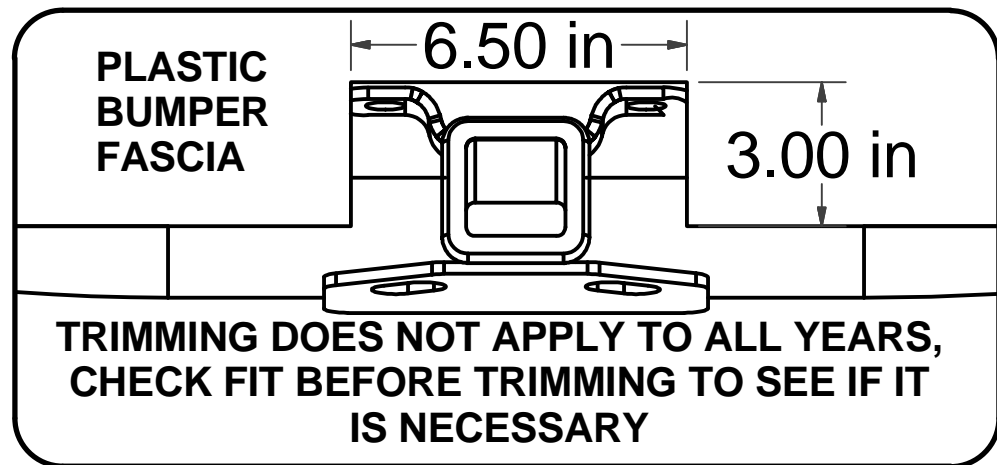

HITCH WEIGHT: 30 LBS.

#### INSTALL TIME

PROFESSIONAL: 30 MINUTES

NOVICE (DIY): 60 MINUTES

#### INSTALL NOTES:

- NO DRILLING REQUIRED
- FASCIA TRIMMING MAY BE REQUIRED FOR SOME MODELS
- CHECK FASCIA BEFORE TRIMMING

## INSTALLATION STEPS

- 1) Lower spare tire and remove existing M14 hex bolts from each frame rail.
- 2) Raise hitch into position and secure bumper mount with M14 hex bolts and lock washers as shown. (Leave bolts loose.)
- 3) Install M14 hardware in rear holes of hitch and install 1/2" carriage bolts, spacers, and flange nuts in remaining holes as shown.
- 4) Torque rear M14 bolt first to 126 lb-ft and all 1/2" fasteners to 110 lb.-ft.
- 5) Reinstall spare tire removed in step (1).

PERIODICALLY CHECK THIS RECEIVER HITCH TO ENSURE THAT ALL FASTENERS ARE TIGHT AND THAT ALL STRUCTURAL COMPONENTS ARE SOUND.

Keystone Automotive Operations Inc., warrants this product to be free of defects in material and/or workmanship at the time of retail purchase by the original purchaser. If the product is found to be defective, Keystone Automotive Operations Inc., may repair or replace the product, at their option, when the product is returned, prepaid, with proof of purchase. Alteration to, misuse of, or improper installation of this product voids the warranty. Keystone Automotive Operations Inc.'s liability is limited to repair or replacement of products found to be defective, and specifically excludes liability for incidental or consequential loss or damage. This product complies with safety specifications and requirements for connecting devices and towing systems of the state of New York, V.E.S.C.

11202017