

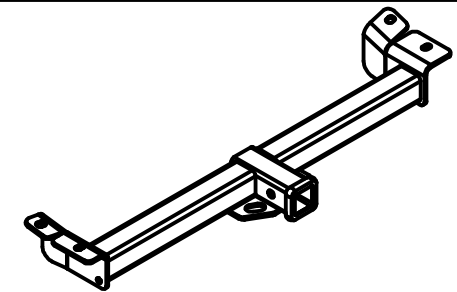

# Class III Receiver Hitch Part No. 69612C



**Fits: 97-06 JEEP WRANGLER**



**GROSS LOAD CAPACITY WHEN USED AS A WEIGHT CARRYING HITCH: 4,000 LBS. TRAILER WEIGHT & 400 LBS. TONGUE WEIGHT.**  
**WARNING: \*\*\* DO NOT EXCEED VEHICLE MANUFACTURER'S RECOMMENDED TOWING CAPACITY. \*\*\***



Parts List			
ITEM	QTY	PART NUMBER	DESCRIPTION
1	1	CM-500-FW	FISHWIRE TOOL
2	2	HFN 1213	HEX FLANGE NUT
3	2	7/16-14 x 1 3/4	HEX BOLT
4	2	M12 - 1.75 x 50mm	HEX BOLT
5	2	CM-SP10	.250 x 1.00 x 2.50" SQUARE HOLE SPACER
6	2	1/2"	CONICAL TOOTHED WASHER
7	2	1/2-13 x 1 3/4	CARRIAGE BOLT

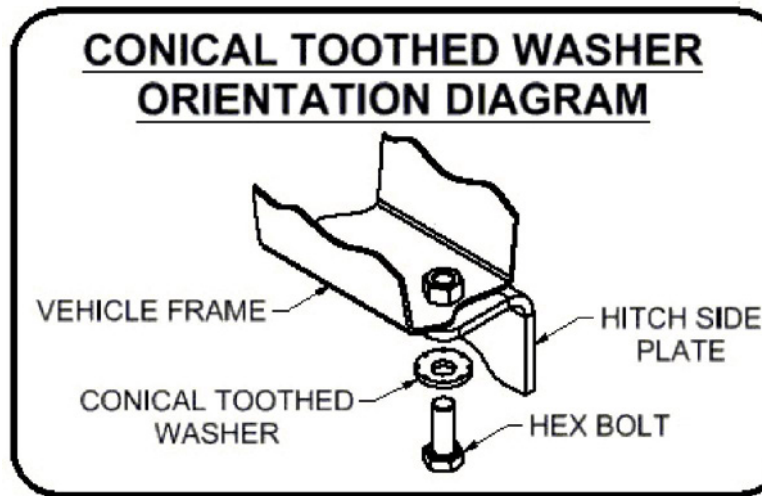

TOOLS REQUIRED
RATCHET
TORQUE WRENCH
9" EXTENSION
SWIVEL SOCKET
18mm SOCKET
19mm SOCKET
5/8" SOCKET
3/4" SOCKET

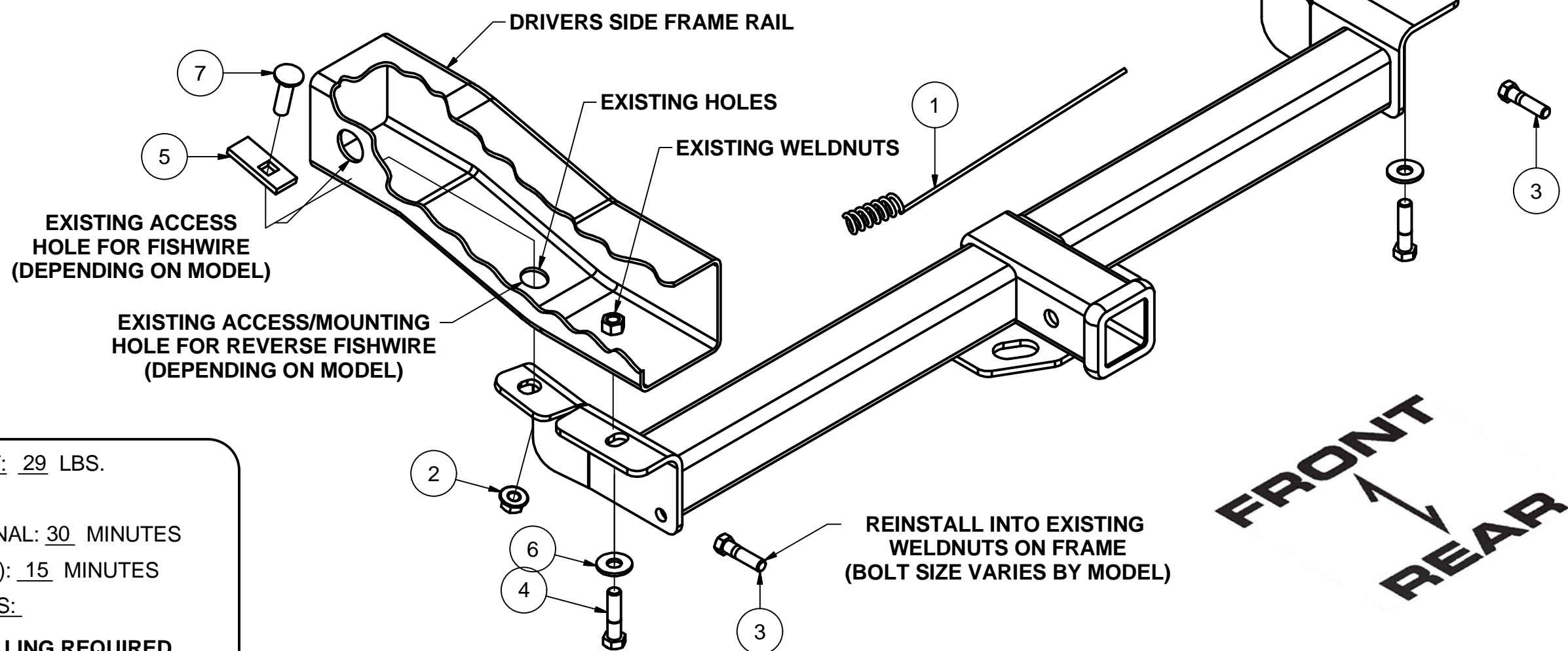
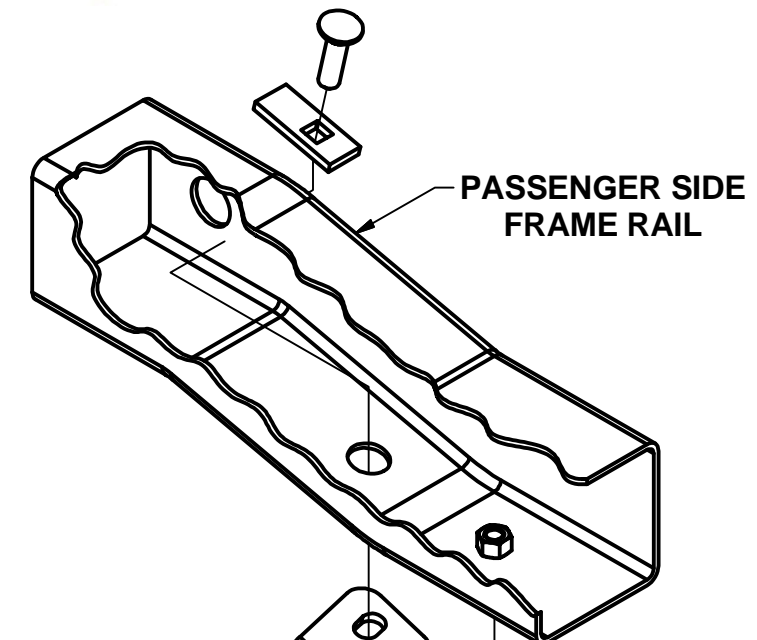
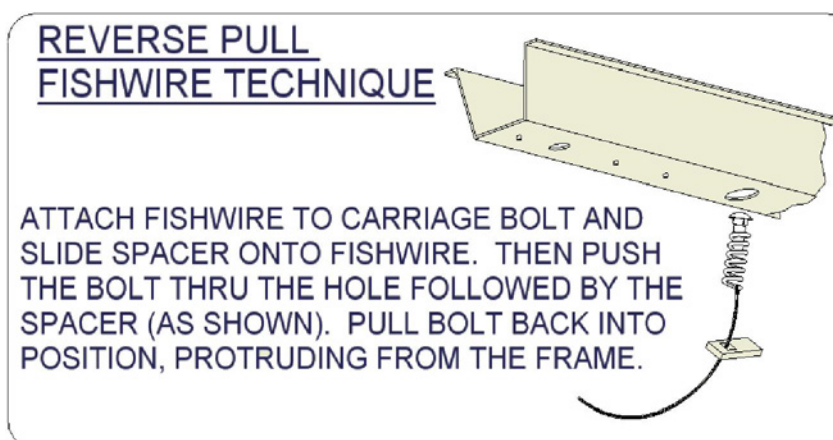
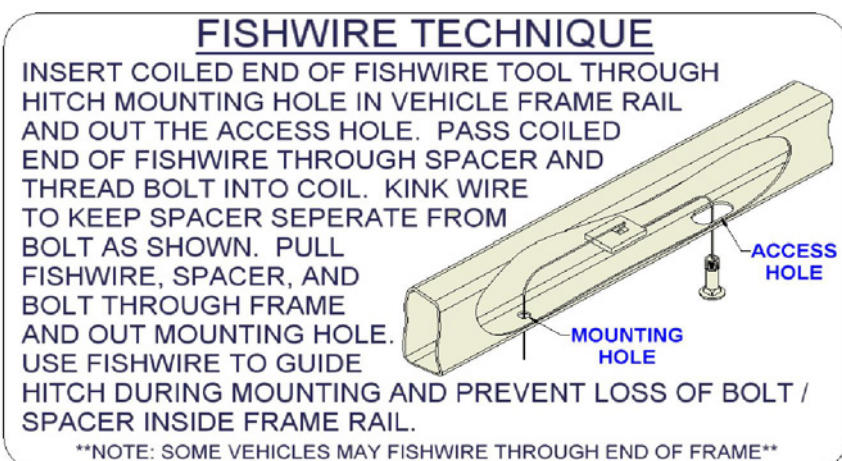

**HITCH WEIGHT:** 29 LBS.  
**INSTALL TIME**  
 PROFESSIONAL: 30 MINUTES  
 NOVICE (DIY): 15 MINUTES  
**INSTALL NOTES:**  
 - NO DRILLING REQUIRED

## INSTALLATION STEPS

1. Remove existing bolt from rear most hole in the vehicle frame. **Note:** These bolts hold bumper in place.
2. Fishwire or reverse fishwire the 1/2" carriage bolts and spacers through access holes and out existing holes in bottom of frame. See Fishwire or Reverse Fishwire Technique.  
**Note:** Access hole locations vary by vehicle.
3. Install remaining fasteners into existing weldnuts, as shown.  
**Note:** Use of the 12mm or 7/16" bolts vary by vehicle.
4. Torque all 7/16" fasteners to 70 lb-ft.  
Torque all 1/2" fasteners to 110 lb-ft.  
Torque all 12mm fasteners to 79 lb-ft.

PERIODICALLY CHECK THIS RECEIVER HITCH TO ENSURE THAT ALL FASTENERS ARE TIGHT AND THAT ALL STRUCTURAL COMPONENTS ARE SOUND.

Keystone Automotive Operations Inc., warrants this product to be free of defects in material and/or workmanship at the time of retail purchase by the original purchaser. If the product is found to be defective, Keystone Automotive Operations Inc., may repair or replace the product, at their option, when the product is returned, prepaid, with proof of purchase. Alteration to, misuse of, or improper installation of this product voids the warranty. Keystone Automotive Operations Inc.'s liability is limited to repair or replacement of products found to be defective, and specifically excludes liability for incidental or consequential loss or damage. This product complies with safety specifications and requirements for connecting devices and towing systems of the state of New York, V.E.S.C.

11202017