

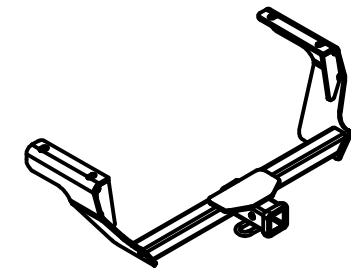

Class III Receiver Hitch

Part No. 69605C



Fits: SUBARU (XV) CROSSTREK



GROSS LOAD CAPACITY WHEN USED AS A WEIGHT CARRYING HITCH: 3,500 LBS. TRAILER WEIGHT & 525 LBS. TONGUE WEIGHT.
WARNING: * DO NOT EXCEED VEHICLE MANUFACTURER'S RECOMMENDED TOWING CAPACITY. *****



Parts List			
ITEM	QTY	PART NUMBER	DESCRIPTION
1	2	13135-SP	.250 x 1.00 x 3.50" SQUARE HOLE SPACER
2	2	1/2-13 x 1 1/2	CARRIAGE BOLT
3	2	7/16-14 x 1 1/2	CARRIAGE BOLT
4	2	CM-SP11	.250 x 1.00 x 2.50" SQUARE HOLE SPACER
5	2	CM-SP16	.250 x 1.50 x 2.00" ROUND HOLE SPACER
6	2	HFN 1213	HEX FLANGE NUT
7	2	7/16-14	HEX FLANGE NUT
8	1	7_16 FISHWIRE	7/16" FISHWIRE
9	1	1_2 FISHWIRE	1/2" FISHWIRE

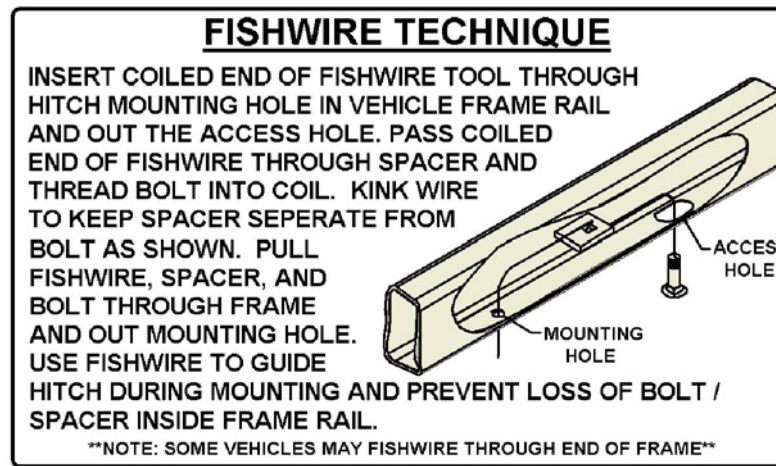

TOOLS REQUIRED

3/8" DRIVE RATCHET
11/16" - 3/8" DRIVE SOCKET
3/4" - 3/8" DRIVE SOCKET
DIE GRINDER W/ RASP BIT
3/8" DRIVE TORQUE WRENCH

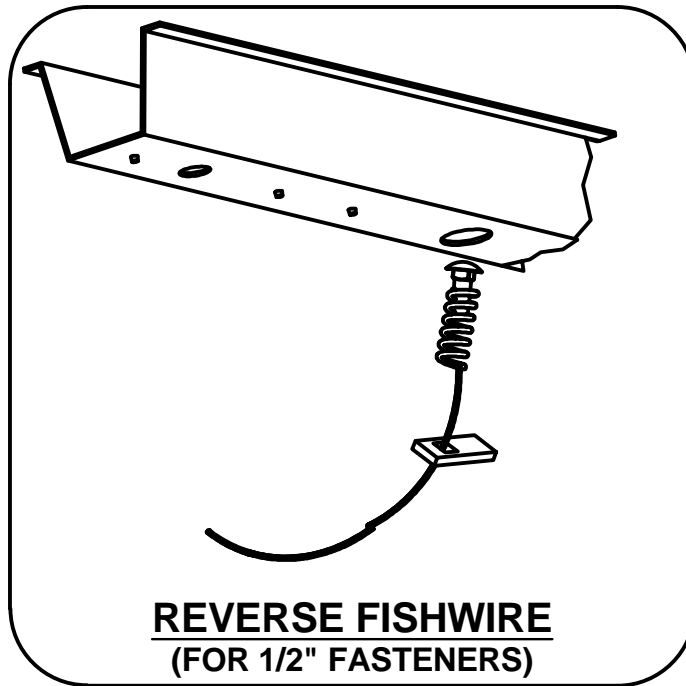

FRONT
↑
REAR

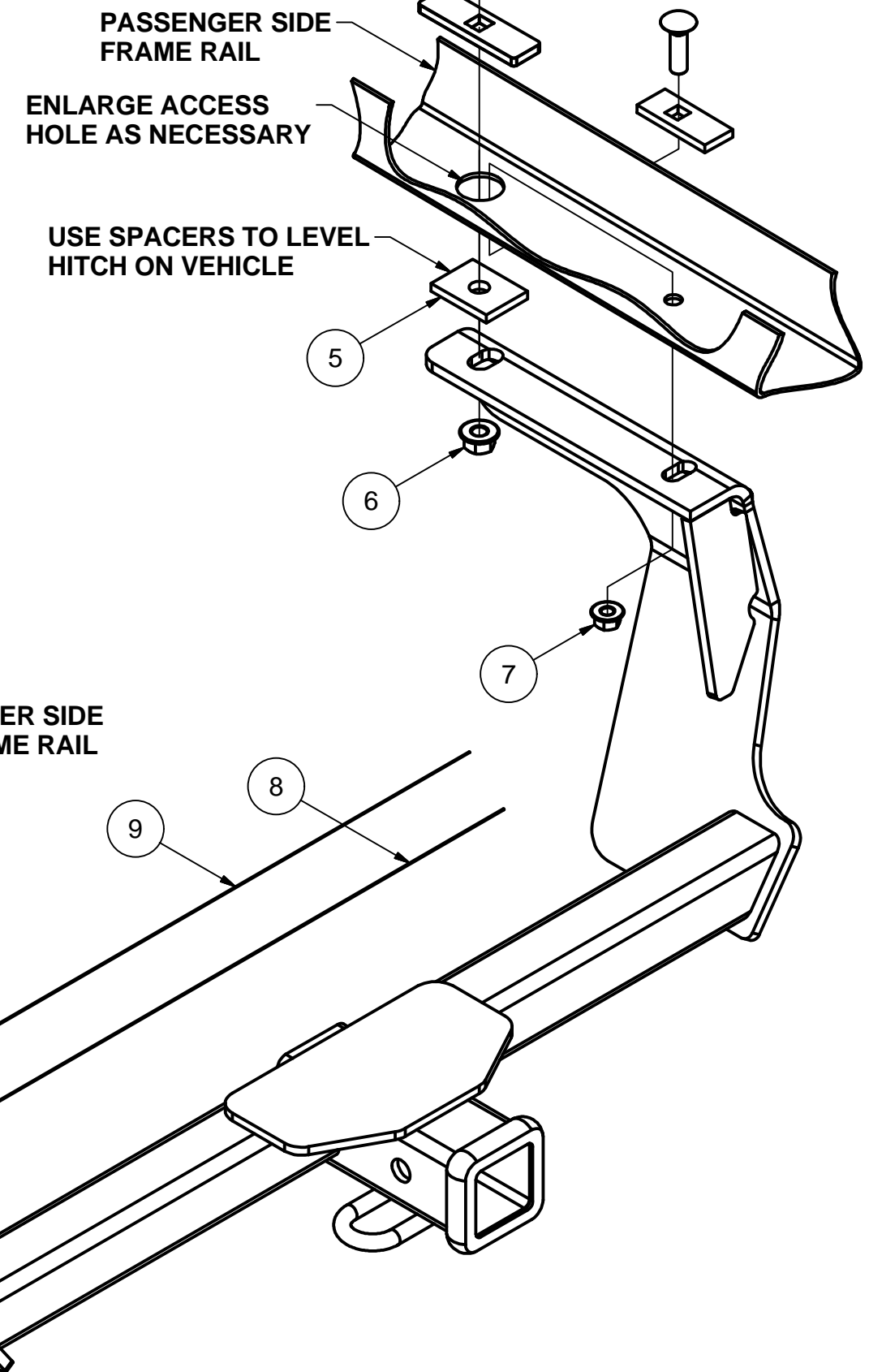

HITCH WEIGHT: 34 LBS.

INSTALL TIME

PROFESSIONAL: 30 MINUTES

NOVICE (DIY): 60 MINUTES

INSTALL NOTES:

- HOLE ENLARGEMENT REQUIRED
- FISHWIRE HARDWARE
- REVERSE FISHWIRE HARDWARE

INSTALLATION STEPS

- 1) Remove the (4) plugs in the frame rails and discard (leave center plugs in).
- 2) Fishwire 7/16" carriage bolts and spacers into position first and reverse fishwire the 1/2" carriage bolts and spacers into position afterward. (enlarge access hole as necessary)
- 3) Raise hitch to the frame aligning the holes in the hitch with the bolts. Use 1.50" x 2.00" spacers to level hitch as necessary.

NOTE: Be careful not to push the bolts in the frame.

4) Install remaining supplied hardware, as shown above.

5) Torque all 7/16" fasteners to 70 lb-ft, and all 1/2" fasteners to 110 lb-ft.

PERIODICALLY CHECK THIS RECEIVER HITCH TO ENSURE THAT ALL FASTENERS ARE TIGHT AND THAT ALL STRUCTURAL COMPONENTS ARE SOUND.

Keystone Automotive Operations Inc., warrants this product to be free of defects in material and/or workmanship at the time of retail purchase by the original purchaser. If the product is found to be defective, Keystone Automotive Operations Inc., may repair or replace the product, at their option, when the product is returned, prepaid, with proof of purchase. Alteration to, misuse of, or improper installation of this product voids the warranty. Keystone Automotive Operations Inc.'s liability is limited to repair or replacement of products found to be defective, and specifically excludes liability for incidental or consequential loss or damage. This product complies with safety specifications and requirements for connecting devices and towing systems of the state of New York, V.E.S.C.

11202017

Rely only on high-grade trailer hitches & towing offered on our virtual shelves.