

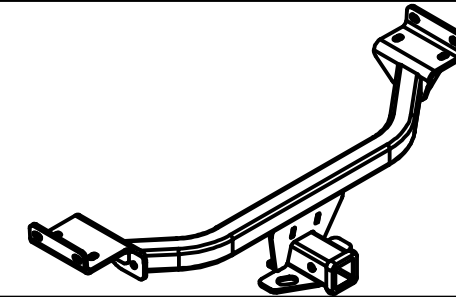

Class III Receiver Hitch Part No. 69603C



Fits: KIA SPORTAGE



GROSS LOAD CAPACITY WHEN USED AS A WEIGHT CARRYING HITCH: 3,500 LBS. TRAILER WEIGHT & 525 LBS. TONGUE WEIGHT.
WARNING: * DO NOT EXCEED VEHICLE MANUFACTURER'S RECOMMENDED TOWING CAPACITY. *****



Parts List			
ITEM	QTY	PART NUMBER	DESCRIPTION
1	8	M10 - 1.25 x 30	HEX BOLT
2	8	7/16"	CONICAL TOOTHED WASHER

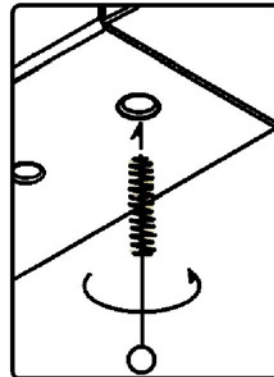

WELDNUT CLEANING

To remove debris from weldnuts in frame, spray lubricant or compressed air into hole. For heavy debris, use a small wire brush. (Be careful not to damage threads).

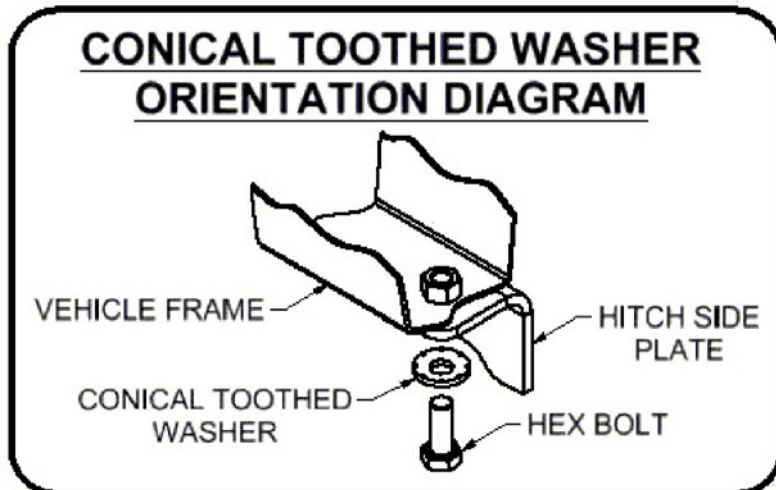
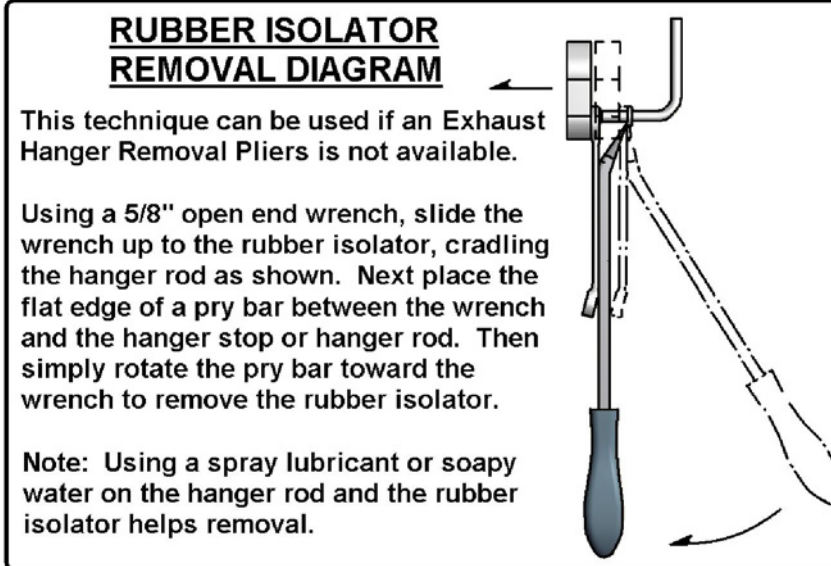

TOOLS REQUIRED	
RATCHET	
17mm SOCKET	
TORQUE WRENCH	
6 in. SOCKET EXTENSION	
FLATHEAD SCREWDRIVER	
SAFETY GLASSES	

HITCH WEIGHT: 33 LBS.
INSTALL TIME
PROFESSIONAL: 20 MINUTES
NOVICE (DIY): 40 MINUTES

INSTALL NOTES:
-NO DRILLING REQUIRED
-LOWER EXHAUST
-TEMPORARILY REMOVE UNDERBODY PANELS

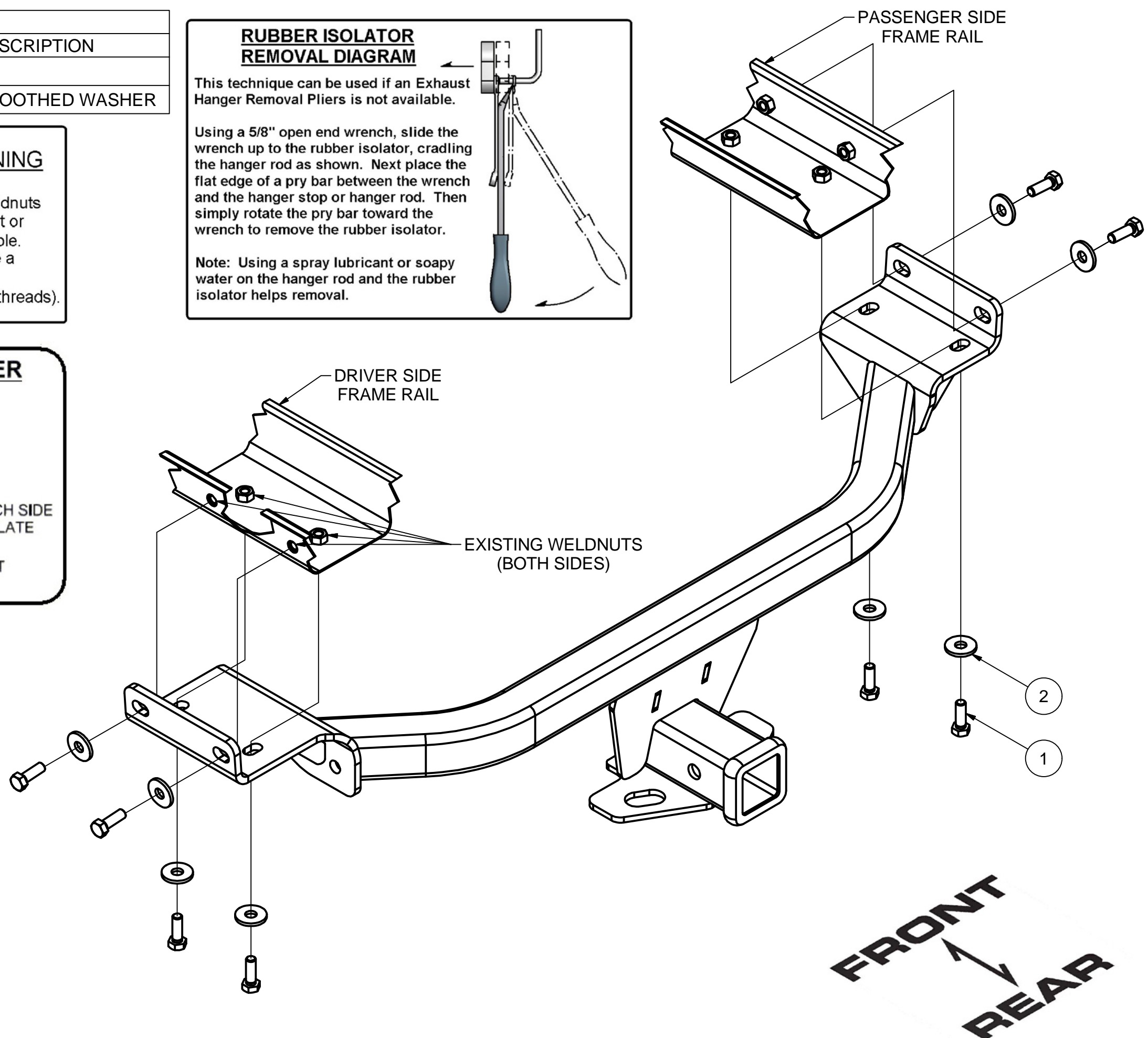

INSTALLATION STEPS

1. Remove (3) plastic clips attaching the panel cover on the driver and passenger side of vehicle. Pull panel covers downward to remove from vehicle. Retain hardware and panels for reinstallation.

Note: The white fasteners that attach the panel covers to studs on the vehicle may pull off the covers during cover removal. Unthread the fasteners from the studs and reinsert the fasteners into position on the panel covers.

2. Lower exhaust by detaching (2) exhaust isolators.

3. Raise hitch into position and secure to vehicle using M10 hardware and 7/16" conical toothed washers, as shown.

4. Torque M10 hardware to 48 lb-ft.

5. Raise exhaust back into position and reattach exhaust isolators removed in Step 2.

6. Reinstall underbody panels removed in Step 1.

PERIODICALLY CHECK THIS RECEIVER HITCH TO ENSURE THAT ALL FASTENERS ARE TIGHT AND THAT ALL STRUCTURAL COMPONENTS ARE SOUND.

Keystone Automotive Operations Inc., warrants this product to be free of defects in material and/or workmanship at the time of retail purchase by the original purchaser. If the product is found to be defective, Keystone Automotive Operations Inc., may repair or replace the product, at their option, when the product is returned, prepaid, with proof of purchase. Alteration to, misuse of, or improper installation of this product voids the warranty. Keystone Automotive Operations Inc.'s liability is limited to repair or replacement of products found to be defective, and specifically excludes liability for incidental or consequential loss or damage. This product complies with safety specifications and requirements for connecting devices and towing systems of the state of New York, V.E.S.C.

11202017